



Installation Operation Maintenance

Indoor liquid chiller with integrated hydraulic module

Water-cooled: CGWN 205 - 206 - 207 - 208 - 209 - 210 -
211 - 212 - 213 - 214 - 215

Condenserless: CCUN 205 - 206 - 207 - 208 - 209 - 210 -
211 - 212 - 213 - 214 - 215

AquaStream²®





General information

Foreword

These instructions are given as a guide to good practice in the installation, start-up, operation, and maintenance by the user, of Trane CGWN/CCUN chillers. They do not contain full service procedures necessary for the continued successful operation of this equipment. The services of a qualified technician should be employed through the medium of a maintenance contract with a reputable service company. Read this manual thoroughly before unit start-up.

Units are assembled, pressure tested, dehydrated, charged and run tested before shipment.

Warnings and cautions

Warnings and Cautions appear at appropriate sections throughout this manual. Your personal safety and the proper operation of this machine require that you follow them carefully. The constructor assumes no liability for installations or servicing performed by unqualified personnel.

WARNING! : Indicates a potentially hazardous situation which, if not avoided, could result in death or serious injury.

CAUTION! : Indicates a potentially hazardous situation which, if not avoided, may result in minor or moderate injury. It may also be used to alert against unsafe practices or for equipment or property-damage-only accidents.

Safety recommendations

To avoid death, injury, equipment or property damage, the following recommendations should be observed during maintenance and service visits:

1. The maximum allowable pressures for system leak testing on low and high pressure side are given

in the chapter "Installation". Always provide a pressure regulator.

2. Disconnect the main power supply before any servicing on the unit.

3. Service work on the refrigeration system and the electrical system should be carried out only by qualified and experienced personnel.

Reception

On arrival, inspect the unit before signing the delivery note.

Reception in France only:

In case of visible damage: The consignee (or the site representative) must specify any damage on the delivery note, legibly sign and date the delivery note, and the truck driver must countersign it. The consignee (or the site representative) must notify Trane Epinal Operations - Claims team and send a copy of the delivery note. The customer (or the site representative) should send a registered letter to the last carrier within 3 days of delivery.

Note: for deliveries in France, even concealed damage must be looked for at delivery and immediately treated as visible damage.

Reception in all countries except France:

In case of concealed damage: The consignee (or the site representative) must send a registered letter to the last carrier within 7 days of delivery, claiming for the described damage. A copy of this letter must be sent to Trane Epinal Operations - Claims team.

Warranty

Warranty is based on the general terms and conditions of the manufacturer. The warranty is void if the equipment is repaired or modified without the written approval of the manufacturer, if the



General information

operating limits are exceeded or if the control system or the electrical wiring is modified. Damage due to misuse, lack of maintenance or failure to comply with the manufacturer's instructions or recommendations is not covered by the warranty obligation. If the user does not conform to the rules of this manual, it may entail cancellation of warranty and liabilities by the manufacturer.

Refrigerant

The refrigerant provided by the manufacturer meets all the requirements of our units. When using recycled or reprocessed refrigerant, it is advisable to ensure its quality is equivalent to that of a new refrigerant. For this, it is necessary to have a precise analysis made by a specialized laboratory. If this condition is not respected, the manufacturer warranty could be cancelled.

Environmental Protection / Compliance with F-Gas regulation

This equipment contains a fluorinated gas covered by the Kyoto Protocol [or an ozone depleting substance covered by Montreal Protocol]. The type and quantity of refrigerant per circuit is indicated on the product nameplate. The Global Warming Potential of the refrigerant implemented in Trane Air Conditioning and Refrigeration Equipment is presented in the table by type of refrigerant.

Refrigerant type	GWP (1) value
R407C	1 653
R410A	1 975

The operator (contractor or end user) must check local environmental regulations impacting installation, operation and disposal of the equipment; in particular need to recover environmentally harmful substances (refrigerant, oil, antifreeze agents, etc.) Do not vent into the atmosphere any refrigerant. The handling of refrigerant shall be fulfilled by a qualified service engineer.

(1) GWP = global warming potential

(2) Covered by Montreal Protocol

Maintenance contract

It is strongly recommended that you sign a maintenance contract with your local Service Agency. This contract provides regular maintenance of your installation by a specialist in our equipment. Regular maintenance ensures that any malfunction is detected and corrected in good time and minimizes the possibility that serious damage will occur. Finally, regular maintenance ensures the maximum operating life of your equipment. We would remind you that failure to respect these installation and maintenance instructions may result in immediate cancellation of the warranty.

Training

To assist you in obtaining the best use of it and maintaining it in perfect operating condition over a long period of time, the manufacturer has at your disposal a refrigeration and air conditioning service school. The principal aim of this is to give operators and technicians a better knowledge of the equipment they are using, or that is under their charge. Emphasis is particularly given to the importance of periodic checks on the unit operating parameters as well as on preventive maintenance, which reduces the cost of owning the unit by avoiding serious and costly breakdown.

Contents

General information	2
----------------------------	----------

General data	5
---------------------	----------

Installation	12
---------------------	-----------

Unit nameplate	12
----------------	----

Installation instructions	12
---------------------------	----

Handling	13
----------	----

Minimal installation water content	16
------------------------------------	----

Water treatment	16
-----------------	----

Water connections	17
-------------------	----

Refrigerant line connections	25
------------------------------	----

Winter freeze protection	31
--------------------------	----

Electrical connections	32
------------------------	----

Interconnection between CCUN and Remote Condenser	36
---	----

Preparation for start-up	38
--------------------------	----

General Start-up	39
-------------------------	-----------

Start-up	39
----------	----

Operation	49
------------------	-----------

Installation checklist	49
------------------------	----

Control and unit operation	50
----------------------------	----

Weekly start up	50
-----------------	----

Weekend shutdown	50
------------------	----

Seasonal shutdown	50
-------------------	----

Seasonal start-up	51
-------------------	----

Maintenance	52
--------------------	-----------

Maintenance Instructions	52
--------------------------	----

Troubleshooting guide	54
-----------------------	----



General Data

Table 1 - Water Cooled units: CGWN standard - R410A

	CGWN 205	CGWN 206	CGWN 207	CGWN 208	CGWN 209	CGWN 210	CGWN 211	
Eurovent Performances (1)								
Net Cooling Capacity	(kW)	182.5	217.0	251.7	283.1	312.1	341.9	373.7
Total Power input in cooling	(kW)	42.5	50.2	57.7	61.5	70.1	78.2	85.9
Evaporator water pressure drop	(kPa)	57	59	55	42	42	50	54
Evaporator head pressure available (4)	(kPa)	161	141	142	149	143	188	176
Condenser water pressure drop	(kPa)	59	64	60	47	52	63	65
Condenser head pressure available	(kPa)	151	134	138	162	150	132	117
Main Power supply					400/3/50			
Sound Power Level (4)	(dBA)	82	82	83	83	84	84	84
Sound Power Level (4) w/ sound attenuation jacket	(dBA)	79	79	80	80	81	81	81
Units Amps								
Nominal (3)	(A)	137	159	187	210	233	250	263
Start-up Amps								
Standard unit	(A)	278	334	395	418	441	512	525
With soft starter option	(A)	210	248	291	314	337	384	397
Short circuit unit capacity	(kA)	15	15	15	15	15	15	15
Max supply cable size	(mm²)	150	150	150	150	150	240	240
Compressor								
Number					4			
Type					Scroll			
Model		(15T + 15T)	(15T + 20T)	(20T + 20T)	(20T + 25T)	(25T + 25T)	(25T + 30T)	(30T + 30T)
Speeds number					1			
Motors Number					1			
Rated Amps (compA/CompB) (3)	(A)	29/29	29/40	40/40	40/52	52/52	52/58	58/58
Locked rotor Amps (compA/CompB)	(A)	170/170	170/215	215/215	215/260	260/260	260/320	320/320
Motor RPM	(rpm)				2900			
Power factor (compA/CompB)		0.88/0.88	0.88/0.87	0.88/0.87	0.87/0.84	0.84/0.84	0.84/0.88	0.88/0.88
Sump Heater (compA/CompB)	(W)				160/160			
Evaporator								
Number					1			
Type					Brazed plate			
Model		DP400-74	DP400-90	DP400-114	DP400-162	DP400-186	DP400-186	DP400-206
Water volume (total)	(L)	15.6	18.9	24.0	34.1	39.2	39.2	43.4
Antifreeze Heater	(W)	-	-	-	-	-	-	-
Evaporator Water Connections					Grooved pipe connection			
Diameter		3"	3"	4"	4"	4"	4"	4"
Max. water-side operating pressure								
without hydraulic module	(kPa)				1000			
with hydraulic module	(kPa)				400			
Condenser								
Number					1			
Type					Brazed plate			
Model		DP400-90	DP400-114	DP400-134	DP400-186	DP400-206	DP400-206	DP400-222
Water volume (total)	(L)	18.9	24.0	28.2	39.2	43.4	43.4	46.7
Antifreeze Heater	(W)	-	-	-	-	-	-	-
Condenser Water Connections					Grooved pipe connection			
Diameter		3 or 4"	3 or 4"	3 or 4"	4"	4"	4"	4"
Max. water-side operating pressure								
without hydraulic module	(kPa)				1000			
with hydraulic module suction/discharge	(kPa)				400/640			
Dimensions								
Height	(mm)	1842	1842	1842	1842	1842	1842	1842
Length	(mm)	2545	2545	2545	2545	2545	2545	2545
Width	(mm)	880	880	880	880	880	880	880
Operating Weight								
Base Unit	(kg)	1360	1300	1420	1500	1650	1710	1790
Evap Hyd Kit	(kg)	1450	1390	1590	1670	1820	1880	1960
Evap + Cds Hyd Kit	(kg)	1520	1460	1690	1770	1920	1980	2060
Shipping Weight								
Base Unit	(kg)	1290	1220	1320	1370	1510	1570	1650
Evap Hyd Kit	(kg)	1380	1310	1490	1540	1680	1740	1820
Evap + Cds Hyd Kit	(kg)	1450	1380	1590	1640	1780	1840	1920
System Data								
Refrigerant circuit					2			
Capacity steps		4	4	4	4	4	4	4
Minimum capacity	%	25	21	25	22	25	23	25
Refrigerant Charge (2)								
Circuit 1 & 2	(kg)	10	11	13	17	18	18	19
Oil Charge (2)								
Circuit 1 & 2	(l)	13.4	13.4	13.4	13.4	13.4	13.9	14.4

(1) at Eurovent Conditions (Evap 12°C/7°C - Condenser. 30°C/35°C)
(2) per circuit
(3) Max rated conditions.
(4) Dual Pump Option



General Data

Table 2 - Water Cooled units: CGWN standard - R407C

		CGWN 212	CGWN 213	CGWN 214	CGWN 215
Eurovent Performances (1)					
Net Cooling Capacity	(kW)	398.6	431.3	466.0	506.4
Total Power input in cooling	(kW)	97.0	106.4	117.3	125.5
Evaporator water pressure drop	(kPa)	40	47	49	48
Evaporator head pressure available (4)	(kPa)	236	218	200	187
Condenser water pressure drop	(kPa)	66	64	59	56
Condenser head pressure available	(kPa)	159	151	147	136
Main Power supply		400/3/50			
Sound Power Level (4)	(dBA)	87	88	88	90
Sound Power Level w/ sound attenuation jacket (4)	(dBA)	84	85	85	87
Units Amps					
Nominal (3)	(A)	311	337	370	400
Start-up Amps					
Standard unit	(A)	563	588	621	655
With soft starter option	(A)	439	465	498	530
Short circuit unit capacity	(kA)	15	15	15	15
Max supply cable size	(mm ²)	185	185	240	240
Compressor					
Number		5	6	6	6
Type		Scroll			
Model		(25T + 30T)	(25T)	(25T + 30T)	(30T)
Speeds number				1	
Motors Number				1	
Rated Amps (compA/CompB) (3)	(A)	52/62.5	52/52	52/62.5	62.5/62.5
Locked rotor Amps (compA/CompB)	(A)	272/310	272/272	272/310	310/310
Motor RPM	(rpm)	2900	2900	2900	2900
Power factor (compA/CompB)		0.87/0.87	0.87/0.87	0.87/0.87	0.87/0.87
Sump Heater (compA/CompB)	(W)	150	150	150	150
Evaporator					
Number		1			
Type		Braze plate			
Model		AC350-190DQ	AC350-190DQ	AC350-210DQ	AC350-230DQ
Water volume (total)	(L)	38	38	42	46
Antifreeze Heater	(W)	-	-	-	-
Evaporator Water Connections		Grooved pipe connections			
Diameter		4"			
Max. water-side operating pressure,					
without hydraulic module	(kPa)	1000	1000	1000	1000
with hydraulic module	(kPa)	400	400	400	400
Condenser					
Number		2			
Type		Braze plate			
Model		B400T- 94p / 114p	B400T- 114p / 114p	B400T- 114p / 144p	B400T- 144p / 144p
Water volume (total)	(L)	19 / 23	23 / 23	23 / 29	29 / 29
Antifreeze Heater	(W)	-	-	-	-
Condenser Water Connections		Grooved pipe connections			
Diameter		5"			
Max. water-side operating pressure,					
without hydraulic module	(kPa)	1000	1000	1000	1000
with hydraulic module	(kPa)	400	400	400	400
Dimensions without Hydraulic Module					
Height	(mm)	1950	1950	1950	1950
Length	(mm)	2808	2808	2808	2808
Width	(mm)	878	878	878	878
Dimensions with Hydraulic Module					
Height	(mm)	1950	1950	1950	1950
Length	(mm)	3498	3498	3498	3498
Width	(mm)	878	878	878	878
Operating Weight					
Base Unit w/o Hyd Kit	(kg)	2232	2442	2525	2640
Base Unit with Hyd Kit	(kg)	2128	2337	2420	2500
Evap Hyd Kit	(kg)	490	490	490	490
Cds Hyd Kit	(kg)	374	374	374	374
Evap + Cds Hyd Kit	(kg)	682	682	682	682
Shipping Weight					
Base Unit w/o Hyd Kit	(kg)	2109	2315	2387	2492
Base Unit with Hyd Kit	(kg)	2048	2253	2326	2408
Evap Hyd Kit	(kg)	432	432	432	432
Cds Hyd Kit	(kg)	317	317	317	317
Evap + Cds Hyd Kit	(kg)	662	662	662	662
System Data					
Number of Refrigerant circuit		2			
Capacity steps		5	6	6	6
Minimum capacity	%	18	16	15	16
Refrigerant Charge (2)					
Circuit A & B	(kg)	22 / 21	22 / 22	25 / 23	26 / 26
Oil Charge (2)					
Circuit A & B	(l)	20.4 / 12.6	20.4 / 20.4	18.9 / 20.4	18.9 / 18.9

(1) at Eurovent Conditions (Evap 12°C/7°C - Condenser 30°C/35°C)
(2) per circuit

(3) Max rated conditions.
(4) Dual Pump Option



General Data

Table 3 - Water Cooled units: CGWN High Efficiency (HE) - R410A

		CGWN 205 HE	CGWN 206 HE	CGWN 207 HE
Eurovent Performances (1)				
Net Cooling Capacity	(kW)	193.3	227.4	262.4
Total Power input in cooling	(kW)	40.1	47.9	55.7
Evaporator water pressure drop	(kPa)	26	36	37
Evaporator head pressure available (4)	(kPa)	188	156	160
Condenser water pressure drop	(kPa)	31	42	41
Condenser head pressure available	(kPa)	177	154	173
Main Power supply				
Sound Power Level (4)	(dBA)	82	82	83
Sound Power Level w/ sound attenuation jacket (4)	(dBA)	79	79	80
Units Amps				
Nominal (3)	(A)	137	159	187
Start-up Amps				
Standard unit	(A)	278	334	395
With soft starter option	(A)	210	248	291
Short circuit unit capacity	(kA)	15	15	15
Max supply cable size	(mm ²)	150	150	150
Compressor				
Number			4	
Type			Scroll	
Model		(15T + 15T)	(15T + 20T)	(20T + 20T)
Speeds number			1	
Motors Number			1	
Rated Amps (compA/CompB) (3)	(A)	29/29	29/40	40/40
Locked rotor Amps (compA/CompB)	(A)	170/170	170/215	215/215
Motor RPM	(rpm)	2900	2900	2900
Power factor (compA/CompB)		0.88/0.88	0.88/0.87	0.87/0.87
Sump Heater (compA/CompB)	(W)	160/160	160/160	160/160
Evaporator				
Number			1	
Type			Brazed plate	
Model		DV58-138	DV58-154	DV58-170
Water volume (total)	(l)	32.4	32.4	34.1
Antifreeze Heater	(W)		-	
Evaporator Water Connections				
Grooved pipe connections				
Diameter		3" (80)	3" (80)	4" (100)
Max. water-side operating pressure.				
without hydraulic module	(kPa)	1000	1000	1000
with hydraulic module	(kPa)	400	400	400
Condenser				
Number				
Type				Brazed plate
Model		DP400-162	DP400-162	DP400-186
Water volume (total)	(l)	34.1	34.1	39.2
Antifreeze Heater	(W)		-	
Condenser Water Connections				
Grooved pipe connection				
Diameter				3" (80)
Antifreeze heater	(W)		-	
Max. water-side operating pressure				
without hydraulic module	(kPa)	1000	1000	1000
with hydraulic module suction/discharge	(kPa)	400/640	400/640	400/640
Dimensions				
Height	(mm)		1842	
Length	(mm)		2545	
Width	(mm)		880	
Operating Weight				
Base Unit	(kg)	1460	1450	1470
Evap Hyd Kit	(kg)	1550	1540	1640
Evap + Cds Hyd Kit	(kg)	1620	1610	1740
Shipping Weight				
Base Unit	(kg)	1360	1350	1340
Evap Hyd Kit	(kg)	1450	1440	1510
Evap + Cds Hyd Kit	(kg)	1520	1510	1610
System Data				
Refrigerant circuit			2	
Capacity steps		4	4	4
Minimum capacity	%	25	21	25
Refrigerant Charge (2)				
Circuit A & B	(kg)	15	15	17
Oil Charge (2)				
Circuit A & B	(l)	13.4	13.4	13.4

(1) at Eurovent Conditions (Evap 12°C/7°C - Condenser. 30°C/35°C)

(2) per circuit

(3) Max rated conditions.

(4) Dual Pump Option



General Data

Table 4 - Condenserless units: CCUN standard - R410A

		CCUN 205	CCUN 206	CCUN 207	CCUN 208	CCUN 209	CCUN 210	CCUN 211
Eurovent Performances (1)								
Net Cooling Capacity	(kW)	166.3	198.1	230.4	257.7	281.9	311.4	343.8
Total Power input in cooling	(kW)	45.6	53.8	62.0	69.8	77.7	86.4	95.1
Evaporator water pressure drop	(kPa)	48	49	47	35	34	41	46
Evaporator head pressure available (4)	(kPa)	178	161	153	160	157	200	189
Main Power supply		400/3/50						
Sound Power Level (4)	(dBA)	82	82	83	83	84	84	84
Sound Power Level (4) w/ sound attenuation jacket	(dBA)	79	79	80	80	81	81	81
Units Amps								
Nominal (3)	(A)	125	147	172	195	218	236	249
Start-up Amps								
Standard unit	(A)	265	321	381	404	427	498	511
With soft starter option	(A)	198	240	277	300	323	370	383
Short circuit unit capacity	(kA)	15	15	15	15	15	15	15
Max supply cable size	(mm ²)	150	150	150	150	150	240	240
Compressor								
Number		4						
Type		Scroll						
Model		(15T + 15T)	(15T + 20T)	(20T + 20T)	(20T + 25T)	(25T + 25T)	(25T + 30T)	(30T + 30T)
Speeds number		1						
Motors Number		1						
Rated Amps (compA/CompB)	(A)	29/29	29/40	40/40	40/52	52/52	52/58	58/58
Locked rotor Amps (compA/CompB)	(A)	170/170	170/215	215/215	215/260	260/260	260/320	320/320
Motor RPM	(rpm)	2900						
Power factor (compA/CompB)		0.88/0.88	0.88/0.87	0.87/0.87	0.87/0.84	0.84/0.84	0.84/0.88	0.88/0.88
Sump Heater (compA/CompB)	(W)	160/160						
Evaporator								
Number		1						
Type		Braze plate						
Model		DP400-74	DP400-90	DP400-114	DP400-162	DP400-186	DP400-186	DP400-206
Water volume (total)	(L)	15.6	18.9	24.0	34.1	39.2	39.2	43.4
Antifreeze Heater	(W)	-	-	-	-	-	-	-
Evaporator Water Connections								
Grooved pipe connections								
Diameter		3"	3"	4"	4"	4"	4"	4"
Max. water-side operating pressure								
without hydraulic module	(kPa)	1000						
with hydraulic module	(kPa)	400						
Remote condenser connections								
Discharge line diameter circuit 1 & 2		1"3/8	1"3/8	1"3/8	1"5/8	1"5/8	1"5/8	1"5/8
Liquid line diameter circuit 1 & 2		7/8	7/8	7/8	7/8	7/8	1"1/8	1"1/8
Dimensions								
Height	(mm)	1842	1842	1842	1842	1842	1842	1842
Length	(mm)	2545	2545	2545	2545	2545	2545	2545
Width	(mm)	880	880	880	880	880	880	880
Operating Weight								
Base Unit	(kg)	1260	1170	1270	1280	1420	1480	1550
Evap Hyd Kit	(kg)	1350	1260	1440	1450	1590	1650	1720
Shipping Weight								
Base Unit	(kg)	1210	1120	1200	1190	1320	1380	1450
Evap Hyd Kit	(kg)	1300	1210	1370	1360	1490	1550	1620
System Data								
Refrigerant circuit		2						
Capacity steps		4						
Minimum capacity	%	25	21	25	22	25	23	25
Refrigerant Charge (2)								
Holding charge per circuit	(kg)	3	3	3	3	3	3	3
Refrigerant content per circuit (CCUN)	(kg)	8	8	10	13	13	13	14
Oil Charge (2)								
Circuit 1 & 2	(l)	13.4	13.4	13.4	13.4	13.4	13.9	14.4

- (1) Conditions (Evap 12°C/7°C - Saturated discharge 45°C - 5°C subcooling)
- (2) Holding charge per circuit
- (3) Max rated conditions.
- (4) Dual Pump Option



General Data

Table 5 - Condenserless units: CCUN standard - R407C

		CCUN 212	CCUN 213	CCUN 214	CCUN 215
Eurovent Performances (1)					
Net Cooling Capacity	(kW)	385.6	417.3	450.4	486.9
Total Power input in cooling	(kW)	99.0	108.5	120.5	131.1
Evaporator water pressure drop	(kPa)	38	44	46	45
Evaporator head pressure available (4)	(kPa)	242	227	211	197
Main Power supply		400/3/50			
Sound Power Level (4)	(dBA)	87	88	88	90
Sound Power Level w/ sound attenuation jacket (4)	(dBA)	84	85	85	87
Units Amps					
Nominal (3)	(A)	280	306	339	369
Start-up Amps					
Standard unit	(A)	532	557	590	624
With soft starter option	(A)	408	434	467	499
Short circuit unit capacity	(kA)	15	15	15	15
Max supply cable size	(mm ²)	185	185	240	240
Compressor					
Number		5	6	6	6
Type		Scroll			
Model		(25T + 30T)	(25T)	(25T + 30T)	(30T)
Speeds number		1			
Motors Number		1			
Rated Amps (compA/CompB) (3)	(A)	52/62.5	52/52	52/62.5	62.5/62.5
Locked rotor Amps (compA/CompB)	(A)	272/310	272/272	272/310	310/310
Motor RPM	(rpm)	2900	2900	2900	2900
Power factor (compA/CompB)		0.87/0.87	0.87/0.87	0.87/0.87	0.87/0.87
Sump Heater (compA/CompB)	(W)	150	150	150	150
Evaporator					
Number		1			
Type		Braze plate			
Model		AC350-190DO	AC350-190DO	AC350-210DO	AC350-230DO
Water volume (total)	(l)	38	38	42	46
Antifreeze Heater	(W)	no	no	no	no
Evaporator Water Connections		Grooved pipe connections			
Diameter		4"			
Max. water-side operating pressure,					
without hydraulic module	(kPa)	1000	1000	1000	1000
with hydraulic module	(kPa)	400	400	400	400
Remote condenser connections					
Discharge line diameter circuit 1 & 2		2"1/8	2"1/8	2"1/8	2"1/8
Liquid line diameter circuit 1 & 2		1"3/8	1"3/8	1"3/8	1"3/8
Dimensions without Hydraulic Module					
Height	(mm)	1950	1950	1950	1950
Length	(mm)	2808	2808	2808	2808
Width	(mm)	878	878	878	878
Dimensions with Hydraulic Module					
Height	(mm)	1950	1950	1950	1950
Length	(mm)	3498	3498	3498	3498
Width	(mm)	878	878	878	878
Operating Weight					
Base Unit w/o Hyd Kit	(kg)	1879	2070	2120	2180
Base Unit with Hyd Kit	(kg)	1880	2071	2122	2182
Evap Hyd Kit	(kg)	490	490	490	490
Shipping Weight					
Base Unit w/o Hyd Kit	(kg)	1832	2023	2070	2130
Base Unit with Hyd Kit	(kg)	1842	2033	2080	2136
Evap Hyd Kit	(kg)	432	432	432	432
System Data					
Refrigerant circuit		2			
Capacity steps		4	4	4	4
Minimum capacity	%	22	33	30	33
Refrigerant Charge (2)					
Circuit A & B	(kg)	Nitrogen Holding charge			
Refrigerant content per circuit (CCUN)	(kg)	16	16	18	19
Oil Charge (2)					
Circuit A & B	(l)	20.4 / 12.6	20.4 / 20.4	18.9 / 20.4	18.9 / 18.9

(1) Conditions (Evap 12°C/7°C - Saturated discharge 45°C - 5°C subcooling) (3) Max rated conditions.
 (2) per circuit (4) Dual Pump Option



General Data

Table 6 - Condenserless units: CCUN High Efficiency (HE) - R410A

		CCUN 205 HE	CCUN 206 HE	CCUN 207 HE
Eurovent Performances (1)				
Net Cooling Capacity	(kW)	175.0	206.7	239.1
Total Power input in cooling	(kW)	45.6	53.8	62.0
Evaporator water pressure drop	(kPa)	22	29	30
Evaporator head pressure available (4)	(kPa)	190	170	170
Main Power supply			400/3/50	
Sound Power Level (4)	(dBA)	82	82	83
Sound Power Level w/ sound attenuation jacket (4)	(dBA)	79	79	80
Units Amps				
Nominal (3)	(A)	125	147	172
Start-up Amps				
Standard unit	(A)	265	321	381
With soft starter option	(A)	198	240	277
Short circuit unit capacity	(kA)	15	15	15
Max supply cable size	(mm ²)	150	150	150
Compressor				
Number			4	
Type			Scroll	
Model		(15T + 15T)	(15T + 20T)	(20T + 20T)
Speeds number			1	
Motors Number			1	
Rated Amps (compA/CompB) (3)	(A)	29/29	29/40	40/40
Locked rotor Amps (compA/CompB)	(A)	170/170	170/215	215/215
Motor RPM	(rpm)	2900	2900	2900
Power factor (compA/CompB)		0.88/0.88	0.88/0.87	0.87/0.87
Sump Heater (compA/CompB)	(W)	160/160	160/160	160/160
Evaporator				
Number			1	
Type			Brazed plate	
Model		DP400-154	DP400-154	DP400-162
Water volume (total)	(L)	32.4	32.4	34.1
Antifreeze Heater	(W)		-	
Evaporator Water Connections			Grooved pipe connections	
Diameter			3"	
Max. water-side operating pressure				
without hydraulic module	(kPa)	1000	1000	1000
with hydraulic module	(kPa)	400	400	400
Remote condenser connections				
Discharge line diameter circuit 1 & 2			1"3/8	
Liquid line diameter circuit 1 & 2		7/8	7/8	7/8
Dimensions				
Height	(mm)		1842	
Length	(mm)		2545	
Width	(mm)		880	
Operating Weight				
Base Unit	(kg)	1330	1240	1250
Evap Hyd Kit	(kg)	1420	1330	1420
Shipping Weight				
Base Unit	(kg)	1270	1170	1160
Evap Hyd Kit	(kg)	1360	1260	1330
System Data				
Refrigerant circuit			2	
Capacity steps			4	
Minimum capacity	%	25	21	25
Refrigerant Charge (2)				
Holding charge per circuit	(kg)	3	3	3
Refrigerant content per circuit (CCUN)	(kg)	11	11	13
Oil Charge (2)				
Circuit 1 & 2	(l)	13.4	13.4	13.4

(1) Conditions (Evap 12°C/7°C - Saturated discharge 45°C - 5°C subcooling) (3) Max rated conditions.
(2) Holding charge per circuit (4) Dual Pump Option



General Data

Table 7 - Evaporator hydraulic module

		205	206	207	208	209	210	211	212	213	214	215
High head pressure option												
Nb Pump set		1										
Motor (1)(2)	(kW)	4.0	4.0	5.5	5.5	5.5	7.5	7.5	11.0	11.0	11.0	11.0
Rated Amps (1)(2)	(A)	7.5	7.5	11.1	11.1	11.1	14.7	14.7	20.0	20.0	20.0	20.0
Motor RPM	(rpm)	2900										
Low head pressure option												
Nb Pump set		1										
Motor (1)(2)		2.2	2.2	4.0	4.0	4.0	5.5	5.5	4.0	4.0	5.5	5.5
Rated Amps (1)(2)		4.0	4.0	7.5	7.5	7.5	11.1	11.1	7.8	7.8	10.3	10.3
Motor RPM		2900										
Expansion tank volume	(l)	25	25	25	25	25	25	25	35	35	35	35
User volume expansion capacity (3)	(l)	3600	3600	3600	3600	3600	3600	3600	5100	5100	5100	5100
Water strainer diameter		3"	3"	4"	4"	4"	4"	4"	4"	4"	4"	4"
Piping		Steel										

Table 8 - Condenser hydraulic module

		205	206	207	208	209	210	211	212	213	214	215
High head pressure option												
Nb Pump set		2 (in parallel)										
Motor (1)(2)	(kW)	3	3	4	4	4	4	4	7.5	7.5	7.5	7.5
Rated Amps (1)(2)	(A)	6.1	6.1	7.7	7.7	7.7	7.7	7.7	13.8	13.8	13.8	13.8
Motor RPM	(rpm)	2900										
Low head pressure option												
Nb Pump set		2 (in parallel)										
Motor (1)(2)	(kW)	2.2	2.2	3.0	3.0	3.0	3.0	3.0	4.0	4.0	5.5	5.5
Rated Amps (1)(2)	(A)	4.2	4.2	6.1	6.1	6.1	6.1	6.1	7.8	7.8	10.3	10.3
Motor RPM	(rpm)	2900										
Water strainer Diameter		4"	4"	4"	4"	4"	4"	4"	4"	4"	4"	4"
Piping		Steel										

- (1) Per motor
- (2) Dual Pump Option
- (3) Hydrostatic pressure 3 bar at 25°C with 7°C mini



Installation

Unit nameplate

The unit nameplate gives the complete model reference numbers. The unit power rating is shown, and power supplies should not deviate by more than 5% from the rated power. Compressor motor amperage is shown in box I.MAX. The customer's electrical installation must be able to withstand this current.

Clearance

Respect recommended clearance around the unit to allow maintenance operation to take place without obstruction. For minimum clearance, consult the certified submittals, which are available on request from your Trane Agency.

Installation instructions

Foundations

No special foundations are required, provided the supporting surface is flat and level, and can withstand the weight of the unit.

Isolating rubber pads

6 pads are supplied as standard with the machine (55x150mm). They should be placed between the supporting floor and the unit to isolate from the ground. Trane does not recommend to install spring isolators.

Water drain hole

Install a drain hole wide enough to drain away water from the unit in the event of shut-down or repair.

Installation

Handling

A specific lifting method is recommended as follows:

1. 4 lifting points are built into the unit.
2. Slings and spreader bar to be provided by rigger and attached to the 4 lifting points.
3. Minimum rated lifting capacity (vertical) of each sling and spreader bar shall be no less than the tabulated unit shipping weight. Refer to Figures 1 and 2

CAUTION: This unit must be lifted with the outmost care. Avoid shock load by lifting slowly and evenly. To prevent any damage, position the lifting bar so that the slings do not touch the unit.

Figure 1 - Rigging the unit - CGWN - CCUN (205-211)

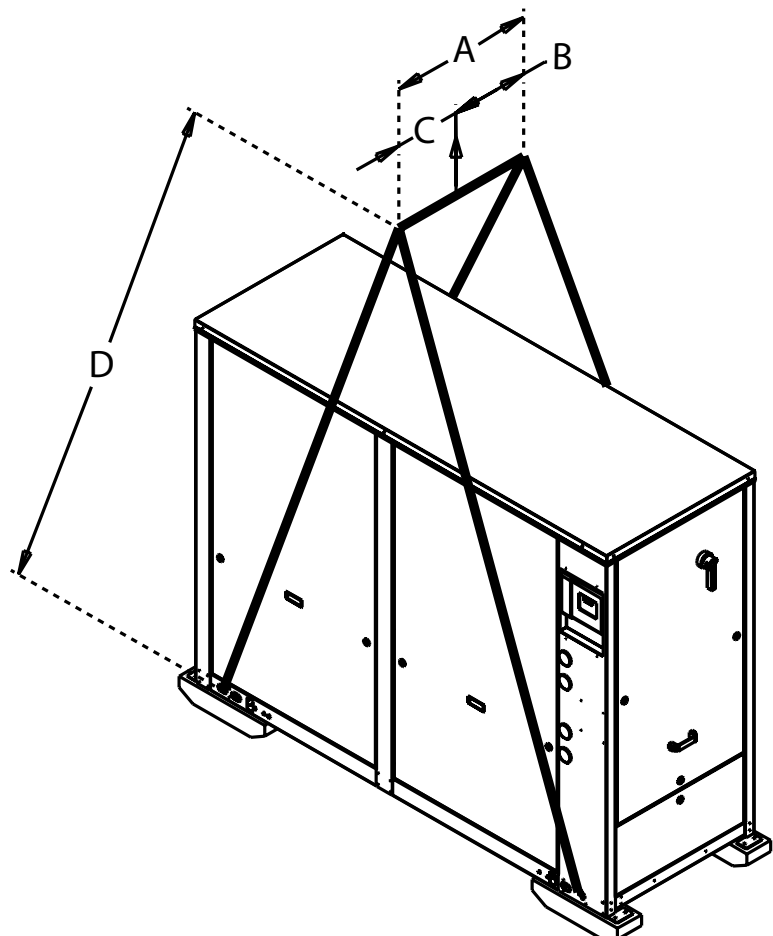

Installation

Figure 2 - Rigging the unit - CGWN - CCUN (212-215)

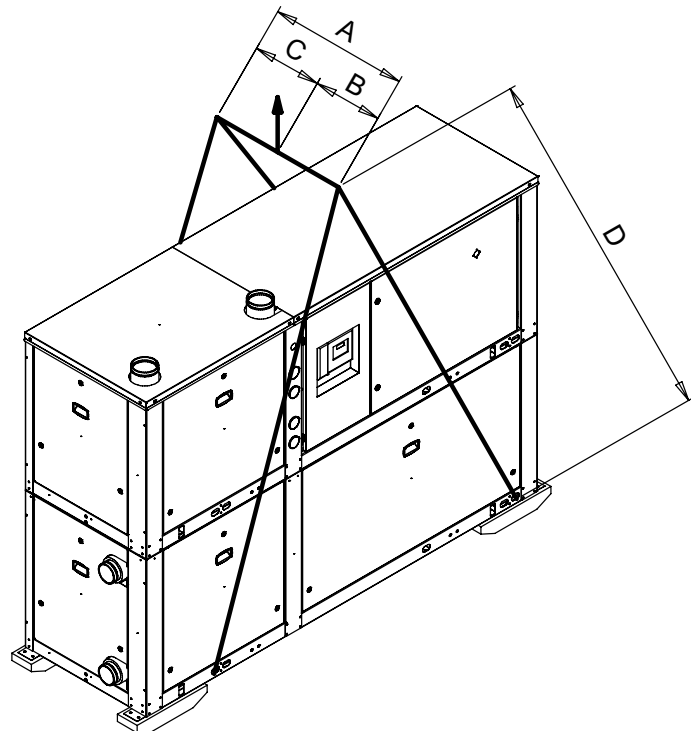
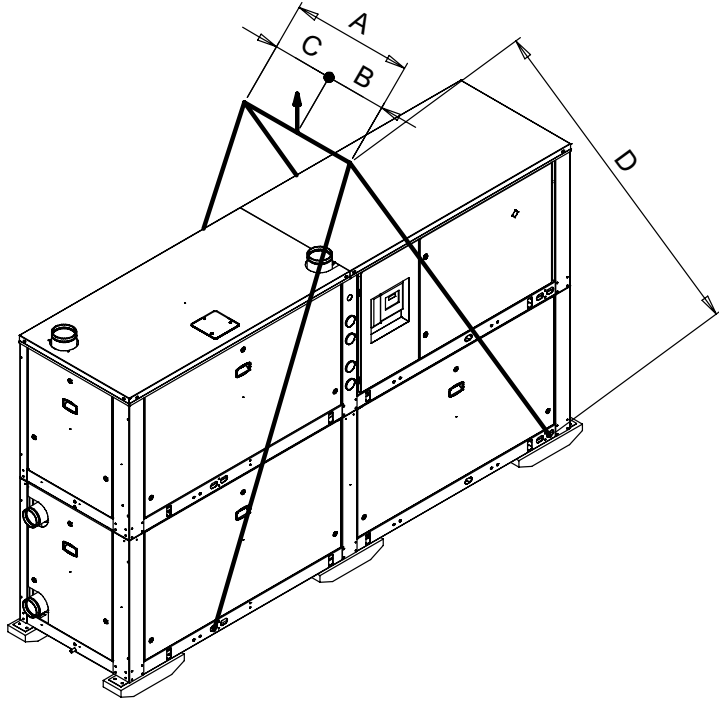

Installation

Table 9 - Dimensions of recommended slings and swing-bar

	A (mm)	B (mm)	C (mm)	D (mm)
CGWN 205				
CGWN 206				
CGWN 207				
CGWN 208				
CGWN 209				
CGWN 210				
CGWN 211				
CGWN 212				
CGWN 213				
CGWN 214				
CGWN 215				
CGWN 205 HE				
CGWN 206 HE				
CGWN 207 HE				
CCUN 205	1100	600	500	2400
CCUN 206				
CCUN 207				
CCUN 208				
CCUN 209				
CCUN 210				
CCUN 211				
CCUN 212				
CCUN 213				
CCUN 214				
CCUN 215				
CCUN 205 HE				
CCUN 206 HE				
CCUN 207 HE				

Installation

Minimal installation water content

The water volume is an important parameter because it allows a stable chilled water temperature and avoids short cycle operation of the compressors.

Parameters which influence the water temperature stability

- Water loop volume
- Load fluctuation
- Number of capacity steps
- Compressors rotation
- Dead band
- Minimum time between 2 starts of a compressor

The following table gives the minimal installation water content recommended according to all these parameters for both comfort and process cooling application.

Water treatment

Untreated or insufficiently treated water, if used in this unit, may cause scale, slime or algae to accumulate or cause erosion and corrosion.

As Trane does not know the components used in the hydraulic network and the quality of the water used, we recommend the services of a qualified water treatment specialist. The following materials are used in Trane chillers heat exchangers:

- Stainless steel plates AISI 316, 1.4401 with copper brazing
- Water piping: steel
- Water connections: brass

Trane will not accept any liability in regards of damage due to the use of untreated or improperly treated water or from the use of saline or brackish water. If water treatment is required, contact your local Trane sales office.

Table 10 - Minimal water content

	Confort Application			Process cooling Application		
	2°C Dead band (1)	3°C Dead band (2)	4°C Dead band (3)	2°C Dead band (1)	3°C Dead band (2)	4°C Dead band (3)
CGWN - CCUN 205	660 l	440 l	330 l	1160 l	730 l	530 l
CGWN - CCUN 206	670 l	450 l	340 l	1160 l	740 l	540 l
CGWN - CCUN 207	650 l	440 l	330 l	1100 l	710 l	520 l
CGWN - CCUN 208	880 l	580 l	440 l	1520 l	960 l	710 l
CGWN - CCUN 209	1060 l	700 l	530 l	1860 l	1170 l	860 l
CGWN - CCUN 210	1080 l	720 l	540 l	1870 l	1190 l	870 l
CGWN - CCUN 211	1260 l	840 l	630 l	2220 l	1400 l	1020 l
CGWN - CCUN 212	1260 l	840 l	630 l	2170 l	1380 l	1010 l
CGWN - CCUN 213	1050 l	700 l	530 l	1760 l	1130 l	830 l
CGWN - CCUN 214	1270 l	850 l	640 l	2150 l	1370 l	1010 l
CGWN - CCUN 215	1240 l	820 l	620 l	2060 l	1330 l	980 l

Notes

- (1) Minimum water loop volume in order to obtain maximum +/- 1°C chilled water temperature fluctuation vs. Chilled water set-point
- (2) Minimum water loop volume in order to obtain maximum +/- 1.5°C chilled water temperature fluctuation vs. Chilled water set-point
- (3) Minimum water loop volume in order to obtain maximum +/- 2°C chilled water temperature fluctuation vs. Chilled water set-point

This table is estimated with

- Condenser : Water 30°/35°C
- Evaporator : Water 12°/7°C



Installation

Water connections

Before making any connections, make sure the labeling for entering and leaving water corresponds to the submittals. CGWN water-cooled chillers and CCUN condenserless units are available in several versions:

1) Evaporator side options

- No hydraulic control
- With pump contactors to control a remote pump (single or dual)
- With pump integrated hydraulic module, single or dual pump, low or high pressure head

2) Condenser side options

- No hydraulic control
- With pump contactors to control a remote pump (single or dual)
- With pump integrated hydraulic module, consisting of two single pumps in parallel to adjust condenser waterflow as a function of unit capacity, low or high pressure head

Typical water circuits are given in the following figures.

CAUTION! To prevent damage to the pump's mechanical seal, it is highly recommended to install a differential pressure switch on the water loop to detect any lack of water flow.

Installation

Figure 3 - CGWN hydraulic flow chart - without hydraulic module (205-215)

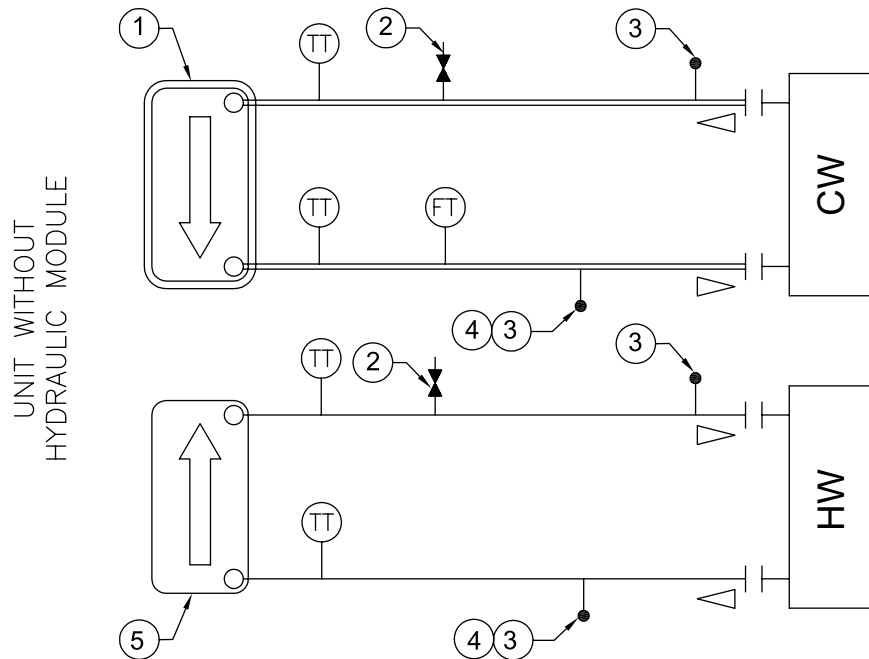

1. Insulated evaporator
2. Valve for air vent
3. 1/4 SAE Male pressure tab
4. 1/4 SAE Male drain tab
5. Condenser

- CW: Chilled water loop
 HW: Condensation water loop
 TT: Temperature sensor
 FT: Water flow switch
- For sizes 205 to 207 standard head 3"
 - For sizes 208 to 215

Installation

Figure 4 - CCUN hydraulic flow chart - without hydraulic module (205-215)

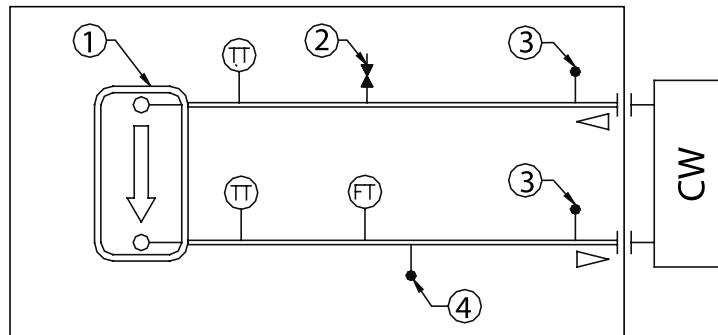

1. Insulated evaporator
2. Valve for air vent
3. 1/4 SAE Male pressure tab
4. 1/4 SAE Male drain tab

- CW: Chilled water loop
 TT: Temperature sensor
 FT: Water flow switch
- For sizes 205 to 207 standard head 3"
 - For sizes 208 to 215

Installation

Figure 5 - CGWN hydraulic flow chart - with hydraulic module on both evaporator and condenser sides (205-211)

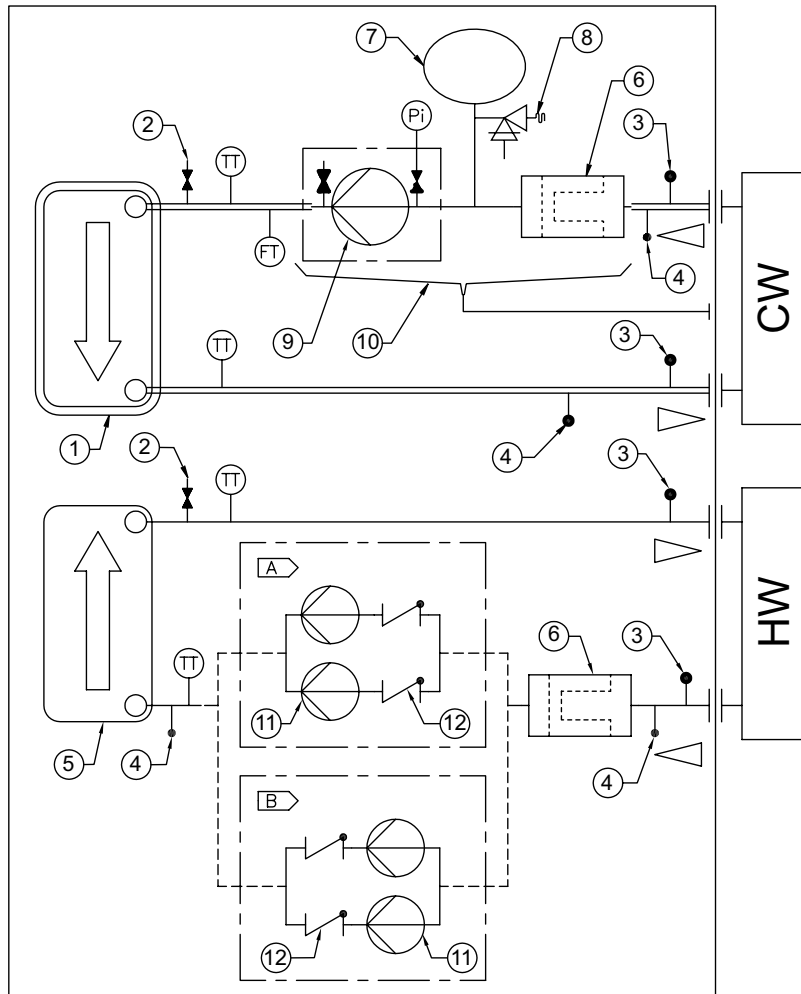

- | | |
|--|---|
| <ol style="list-style-type: none"> 1. Insulated evaporator 2. Valve for air vent 3. ¼ SAE Male pressure tab 4. ¼ SAE Male drain tab 5. Condenser 6. Water strainer 7. Expansion Tank 8. Pressure relief valve 9. Single or double evaporator pump 10. Drain pan 11. Condenser pump 12. Check valve | <p>CW: Chilled water loop
 HW: Condensation water loop
 TT: Temperature sensor
 Pi: Pressure gauge
 FT: Water flow switch</p> <ul style="list-style-type: none"> • For sizes 205 to 207 standard head 3" • For sizes 208 to 215 |
|--|---|

Installation

Figure 6 - CGWN hydraulic flow chart - with hydraulic module on both evaporator and condenser sides (212-215)

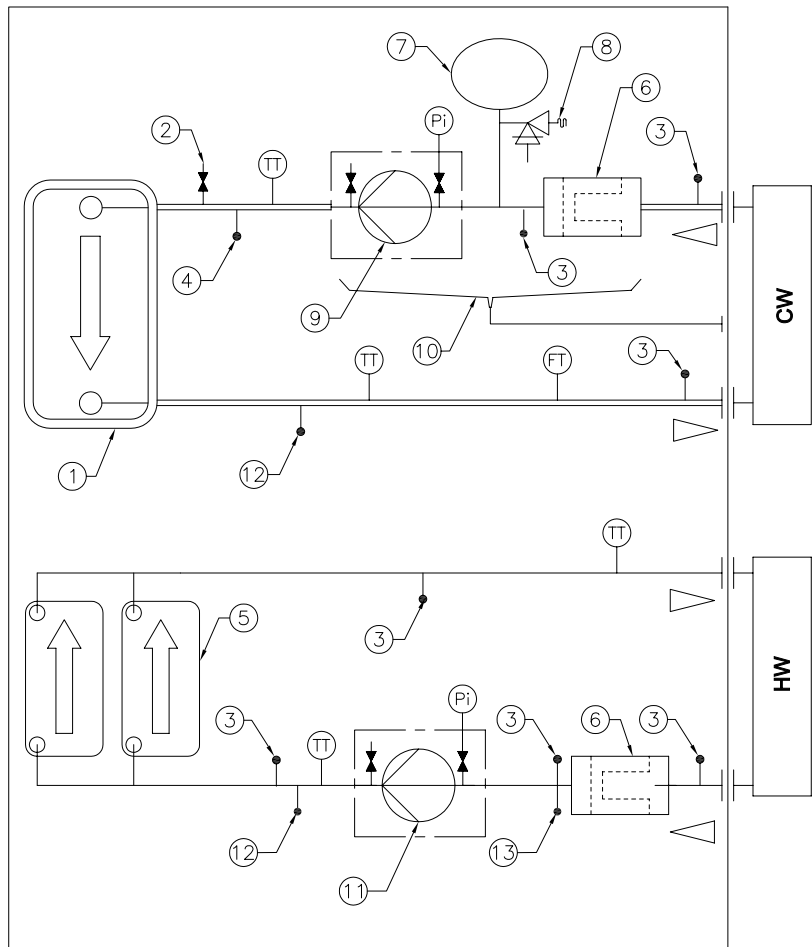

- | | |
|---|---|
| <ol style="list-style-type: none"> 1. Insulated evaporator 2. Valve for air vent 3. ¼ SAE Male pressure tab 4. ¼ SAE Male drain tab 5. Single condenser 6. Water strainer 7. Expansion Tank 8. Pressure relief valve 9. Single or double evaporator pump 10. Drain pan 11. Double condenser pump 12. 1/4 NPT drain tab 13. 3/4 NPT steel tube for expansion tank | <p>CW: Chilled water loop
 HW: Condensation water loop
 TT: Temperature sensor
 Pi: Pressure gauge
 FT: Water flow switch</p> <ul style="list-style-type: none"> • For sizes 205 to 207 standard head 3" • For sizes 208 to 215 |
|---|---|

Installation

Figure 7 - CCUN hydraulic flow chart - with hydraulic module on evaporator side only (205-211)

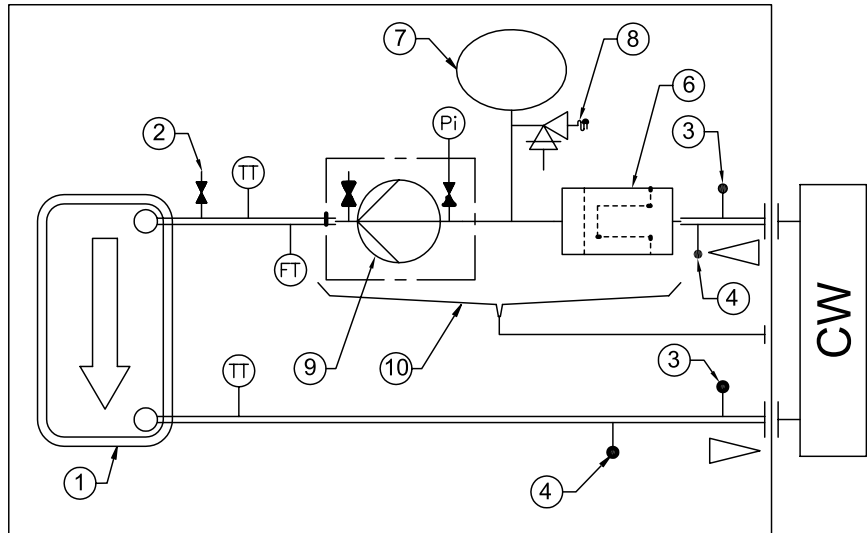

- | | |
|-------------------------------------|--|
| 1. Insulated evaporator | CW: Chilled water loop |
| 2. Valve for air vent | TT: Temperature sensor |
| 3. ¼ SAE Male pressure tab | Pi: Pressure gauge |
| 4. ¼ SAE Male drain tab | FT: Water flow switch |
| 5. Condenser | • For sizes 205 to 207
standard head 3" |
| 6. Water strainer | • For sizes 208 to 215 |
| 7. Expansion Tank | |
| 8. Pressure relief valve | |
| 9. Single or double evaporator pump | |
| 10. Drain pan | |

Installation

Figure 8 - CCUN hydraulic flow chart - with hydraulic module on evaporator side only (212-215)

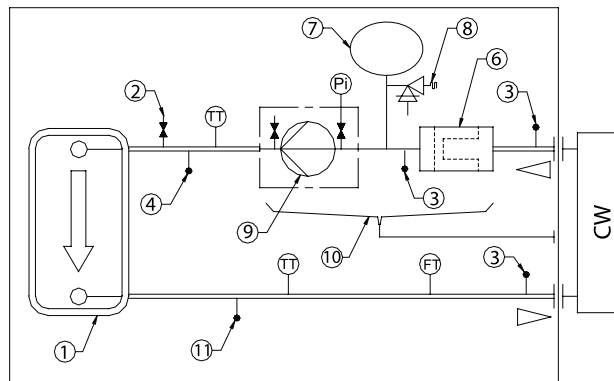

- | | |
|---|--|
| <ol style="list-style-type: none"> 1. Insulated evaporator 2. Valve for air vent 3. ¼ SAE Male pressure tab 4. ¼ SAE Male drain tab 5. Condenser 6. Water strainer 7. Expansion Tank 8. Pressure relief valve 9. Single or double evaporator pump 10. Drain pan 11. Condenser pump | <p>CW: Chilled water loop
 TT: Temperature sensor
 Pi: Pressure gauge
 FT: Water flow switch</p> <ul style="list-style-type: none"> • For sizes 205 to 207 standard head 3" • For sizes 208 to 215 |
|---|--|

WARNING! Units with hydraulic module contain all safety and operation devices and only require the supply and return piping with isolating valves for maintenance of water strainer and pump seal ring.

The unit water piping shall be connected using expansion compensators.

Installation

Figure 9 - Connection of units with hydraulic module - Evaporator and condenser sides

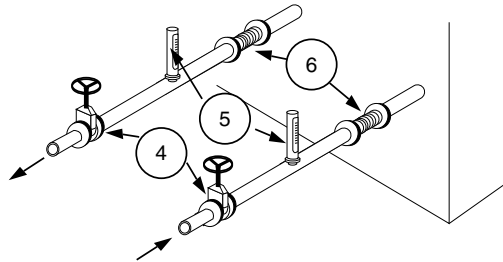
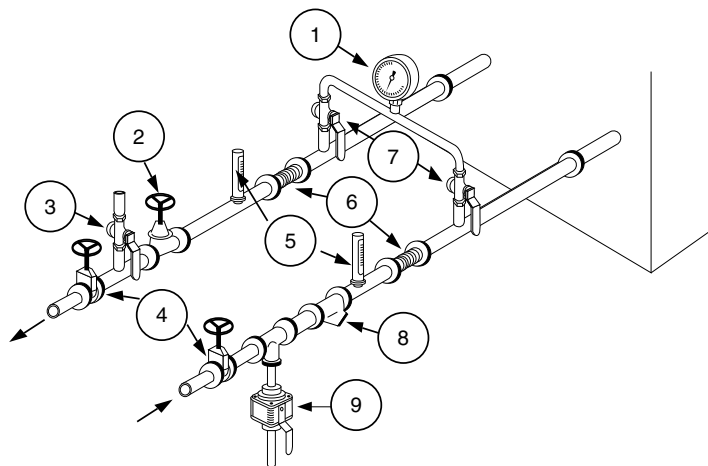

Figure 10 - Connection of units without hydraulic module - Evaporator and condenser sides



- 1 = Pressure gauges: show entering and leaving water pressure (2 pressure ports are available inside of the unit - see item 1 in Figure above)
- 2 = Balancing valve: adjusts water flow.
- 3 = Air purge allows to remove the air from the water circuit during fill up.
- 4 = Stop valves: isolate chillers and water circuiting pump during maintenance operations.
- 5 = Thermometers: indicate chilled water entering and leaving temperatures (not mandatory).
- 6 = Expansion compensators: avoid mechanical stress between chiller and piping installation.
- 7 = Stop valve located on the outlet connection: used to measure the water pressure inlet or outlet of evaporator.
- 8 = Strainer: avoid to get heat exchangers dirty. **All installation must be equipped with efficient strainer in order that only clean water enters into exchanger. If there is no strainer, reserve will be formulated by the Trane technician at the start-up of the unit.**
- 9 = Draining the plate heat exchanger: used to drain

Note: To protect the environment, it is compulsory to recover and process glycol brines.

Installation

Refrigerant line connections

Piping

Maximum distances and refrigerant line diameters between units must be checked according to the configuration and system operating conditions (Chilled water temperature and subcooling).

Tables 11-14 provide the maximum acceptable height according to subcooling available and recommended diameters for discharge liquid lines when CCUN condenserless chillers are connected to remote condensers.

The model CCUN is part of the installation which is protected at 44.5 bar for R410a units and 29.5 bar for R407C units.

The installer must ensure that the entire installation conforms to PED regulations, depending on the characteristics of the condenser used.

Figure 11 - Installation configuration - CCUN and remote condenser at the same level

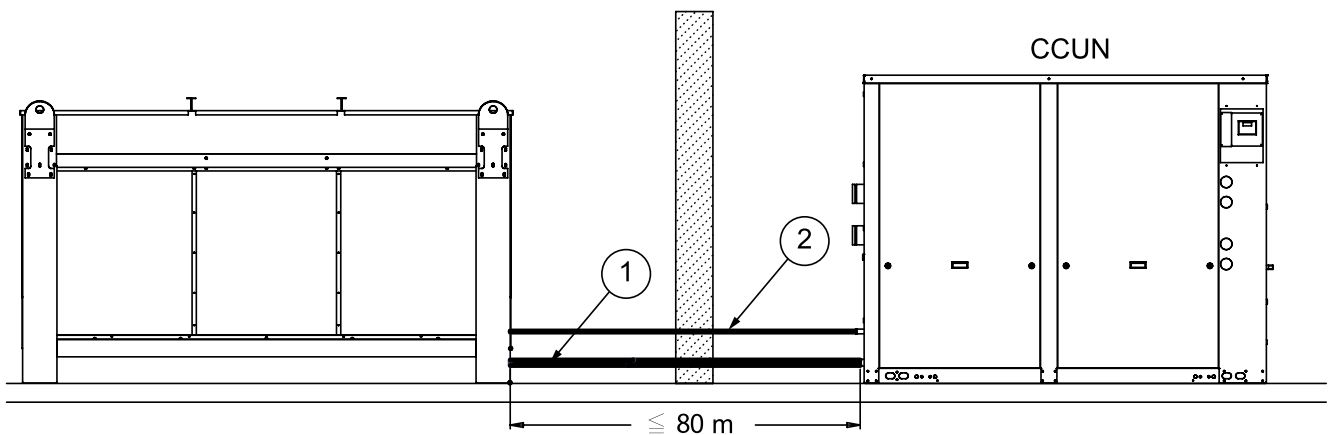

- 1: Discharge line
- 2: Liquid line

Installation

Figure 12 - Installation configuration - CCUN below remote condenser

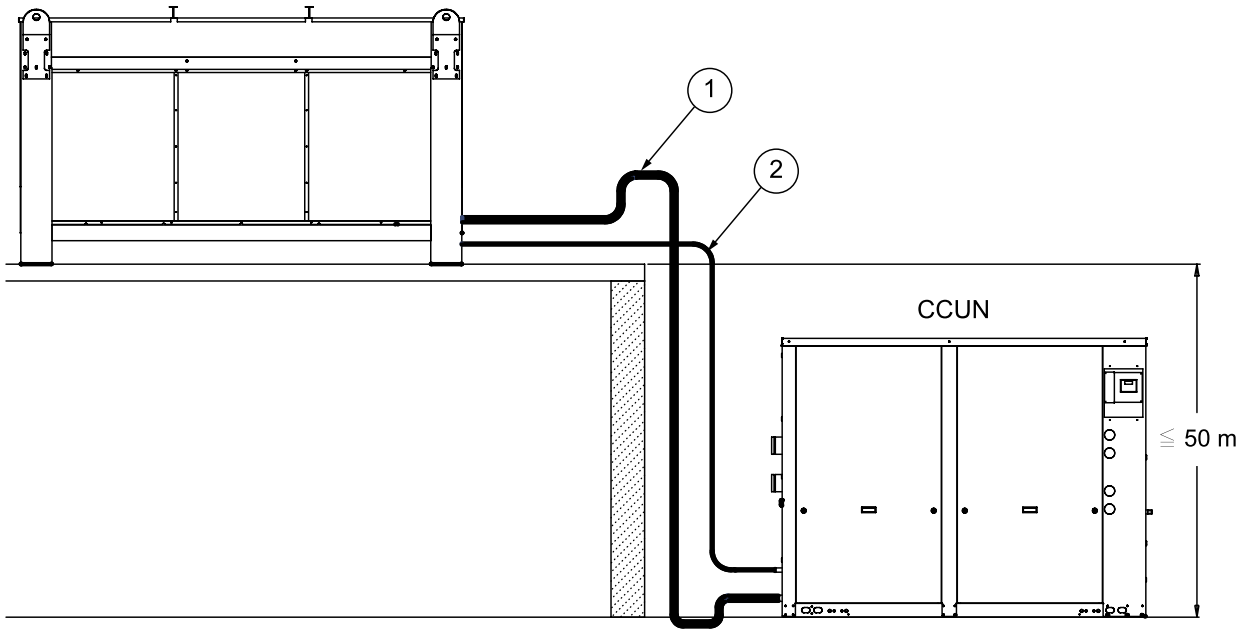

- 1: Discharge line
- 2: Liquid line



Installation

Table 11 - Recommended discharge line diameters for horizontal risers (Circuit 1)

		Leaving chilled water temperature (°C)													
Unit size		-12	-10	-8	-6	-4	-2	0	2	4	6	8	10	12	14
CCUN	205			7/8"					1"1/8					1"3/8	
CCUN	206		7/8"					1"1/8					1"3/8		
CCUN	207		7/8"					1"1/8					1"3/8		
CCUN	208			1"1/8					1"3/8					1"5/8	
CCUN	209			1"1/8					1"3/8					1"5/8	
CCUN	210			1"1/8					1"3/8					1"5/8	
CCUN	211			1"1/8					1"3/8					1"5/8	
CCUN	212			1"5/8					2"1/8						
CCUN	213			1"5/8					2"1/8						
CCUN	214		1"5/8					2"1/8					2"5/8		
CCUN	215		1"5/8					2"1/8					2"5/8		

Table 12 - Recommended discharge line diameters for horizontal risers (Circuit 2)

		Leaving chilled water temperature (°C)													
Unit size		-12	-10	-8	-6	-4	-2	0	2	4	6	8	10	12	14
CCUN	205			7/8"					1"1/8					1"3/8	
CCUN	206		7/8"					1"1/8					1"3/8		
CCUN	207		7/8"					1"1/8					1"3/8		
CCUN	208			1"1/8					1"3/8					1"5/8	
CCUN	209			1"1/8					1"3/8					1"5/8	
CCUN	210			1"1/8					1"3/8					1"5/8	
CCUN	211			1"1/8					1"3/8					1"5/8	
CCUN	212		1"3/8					1"5/8					2"1/8		
CCUN	213			1"5/8					2"1/8						
CCUN	214			1"5/8					2"1/8						
CCUN	215		1"5/8					2"1/8					2"5/8		

Note: CCUN is only one component of a complete installation. It includes its own high pressure protection set at 44.5 bar for R410A units and 29.5 bars for R407C units.

The party in charge of the supply of the condenser and of its refrigerant piping is responsible of implementing all the required protections to comply with the PED requirements for the design pressure of the condenser installed.

Please refer to the document PROD-SVX01_-xx delivered with this chiller to check all the mandatory conformity requirements of the Pressure Equipment and Machinery directives for this installation.



Installation

Table 13 - Recommended liquid line diameters for vertical or horizontal risers (Circuit 1)

		Leaving chilled water temperature (°C)													
	Unit size	-12	-10	-8	-6	-4	-2	0	2	4	6	8	10	12	14
CCUN	205	5/8"				7/8"				1"1/8					
CCUN	206	5/8"	7/8"				1"1/8								
CCUN	207	5/8"	7/8"				1"1/8								
CCUN	208	7/8"				1"1/8				1"3/8					
CCUN	209	7/8"				1"1/8				1"3/8					
CCUN	210	7/8"		1"1/8				1"3/8							
CCUN	211	7/8"		1"1/8				1"3/8							
CCUN	212	1"1/8				1"3/8				1"5/8					
CCUN	213	1"1/8				1"3/8				1"5/8					
CCUN	214	1"1/8		1"3/8				1"5/8							
CCUN	215	1"1/8		1"3/8				1"5/8							

Table 14 - Recommended liquid line diameters for vertical or horizontal risers (Circuit 2)

		Leaving chilled water temperature (°C)													
	Unit size	-12	-10	-8	-6	-4	-2	0	2	4	6	8	10	12	14
CCUN	205	5/8"				7/8"				1"1/8					
CCUN	206	5/8"	7/8"				1"1/8								
CCUN	207	5/8"	7/8"				1"1/8								
CCUN	208	7/8"				1"1/8				1"3/8					
CCUN	209	7/8"				1"1/8				1"3/8					
CCUN	210	7/8"		1"1/8				1"3/8							
CCUN	211	7/8"		1"1/8				1"3/8							
CCUN	212	1"1/8				1"3/8				1"5/8					
CCUN	213	1"1/8				1"3/8				1"5/8					
CCUN	214	1"1/8		1"3/8				1"5/8							
CCUN	215	1"1/8		1"3/8				1"5/8							

Note: CCUN is only one component of a complete installation. It includes its own high pressure protection set at 44.5 bar for R410A units and 29.5 bars for R407C units.

The party in charge of the supply of the condenser and of its refrigerant piping is responsible of implementing all the required protections to comply with the PED requirements for the design pressure of the condenser installed.

Please refer to the document PROD-SVX01_-xx delivered with this chiller to check all the mandatory conformity requirements of the Pressure Equipment and Machinery directives for this installation.

Installation

Insulation

Insulate refrigerant lines from building itself to avoid transmission to building structure of vibrations normally caused by pipework. Also avoid bypassing the unit's damping system by fixing the refrigerant lines or the electrical ducts very rigidly. Vibrations may propagate into building structure through rigidly fixed refrigerant lines.

Pressure tests and leak detection

WARNING! During operations, take the following precaution:

1. Neither oxygen nor acetylene should be used instead of refrigerant and nitrogen to detect leaks, otherwise a violent explosion may occur.
2. Always use valves and manometers to check the test pressure in system. Excessive pressure may either cause pipes to rupture, damage unit, or cause an explosion, causing possible physical injury. Carry out liquid line and hot gas pressure tests in accordance with current standards.

CAUTION: Do not go more than 0.7 bar above the high pressure switch setpoint. Introduce enough refrigerant into circuit for 85 to 100 kPa pressure, pump-injecting dry nitrogen, and raise pressure to 100 kPa. Search possible leaks using detector. This operation should be carried out great care throughout the system. If leaks are detected, reduce system pressure, and repair defective component. Repeat test process, to check that the repair can withstand rated pressure.

Refrigerant charge

CCUN 205-211 units are delivered with a 3kg refrigerant charge per circuit and isolating valves. CCUN 212-215 units are delivered with a nitrogen holding charge and isolating valves. After system pressure and vacuum testing, fill up unit with refrigerant according to the diameter and the length of the refrigerant piping work up to obtain the correct subcooling temperature:

Δt subcooling = 5°C for a liquid temperature of 40°C.

Warning: When connecting CCUN liquid and discharge lines, ensure that the copper end pipes between the stop valve and the end end of the piping are not under pressure using a 1/4 SAE.

Oil charge - CCUN

Above 60 kg of refrigerant charge per circuit, special care to the oil level on compressor is required. The operating oil level shall remain above half of the oil sight glass. See the unit nameplate for oil charges. The oil level can only be evaluated after 10 minutes OFF time of both compressors of the circuit. See sticker for the oil level located on the compressor next to the oil sight glass. See Figure 29.

Note: The oil quantity necessary for the split system has also to be adjusted according to the diameter and the length of the refrigerant piping work.

CAUTION: Use exclusively POE oil recommended by TRANE

Important note:

These operations have to be performed by a specialist. The results have to be written on a start up record by the Trane engineer or the client's specialist who has performed this start up. The quantity of refrigerant and oil added are at the client's charges.

Installation

High pressure

The remote condenser must have a service pressure equal to or higher than the high service pressure (44.5 bar for CCUN 205-211 and 29.5 bar for CCUN 212-215.)

Warning! CCUN 205-211 have a high pressure switch which is not adjustable up to 44.5 bar. CCUN 212-215 have a high pressure switch which is not adjustable up to 29.5 bar.

Note: CCUN is only one component of a complete installation. It includes its own high pressure protection set

at 44.5 bar for R410A units and 29.5 bars for R407C units.

The party in charge of the supply of the condenser and of its refrigerant piping is responsible of implementing all the required protections to comply with the PED requirements for the design pressure of the condenser installed.

Please refer to the document PROD-SVX01 -xx delivered with this chiller to check all the mandatory conformity requirements of the Pressure Equipment and Machinery directives for this installation.

Pressure relief valve - CCUN

Above the maximum system refrigerant charge, it is recommended to install a pressure relief valve. See figures below for installation. Depending upon the liquid line diameter selected in the "Recommended liquid line diameters" table, find the predicted maximum liquid line length of installation without pressure relief valve installed. The recommended pressure relief valve setting is 29 bar for CCUN 205-211 and 21 bar for CCUN 212-215 and shall be installed on the low pressure side of the refrigerant circuit.

Table 15 - Recommended liquid line diameters with pressure relief valve - CCUN

Unit size	Unit efficiency model	Circuit	Maximum system refrigerant charge without pressure relief valve (kg)	Liquid line diameter	Maximum length without pressure relief valve (m)	Liquid line diameter	Maximum length without pressure relief valve (m)
205	Standard	1 & 2	62	1"1/8	76	7/8"	120
	High	1 & 2	69	1"1/8	90	7/8"	142
206	Standard	1 & 2	63	1"1/8	71	7/8"	113
	High	1 & 2	69	1"1/8	83	7/8"	131
207	Standard	1 & 2	65	1"1/8	69	7/8"	108
	High	1 & 2	70	1"1/8	79	7/8"	125
208	Standard	1 & 2	71	1"1/8	73	7/8"	115
209	Standard	1 & 2	74	1"1/8	74	7/8"	116
210	Standard	1 & 2	76	1"3/8	45	1"1/8	70
211	Standard	1 & 2	79	1"3/8	44	1"1/8	69
212	Standard	1	109	1"3/8	76	1" 5/8	54
	Standard	2	77	1"3/8	43	1" 5/8	30
213	Standard	1	109	1"3/8	76	1" 5/8	54
	Standard	2	109	1"3/8	76	1" 5/8	54
214	Standard	1	103	1"3/8	69	1" 5/8	49
	Standard	2	111	1"3/8	74	1" 5/8	53
215	Standard	1	106	1"3/8	67	1" 5/8	48
	Standard	2	106	1"3/8	67	1" 5/8	48

Figure 13 - Installing pressure relief valve (205-211)

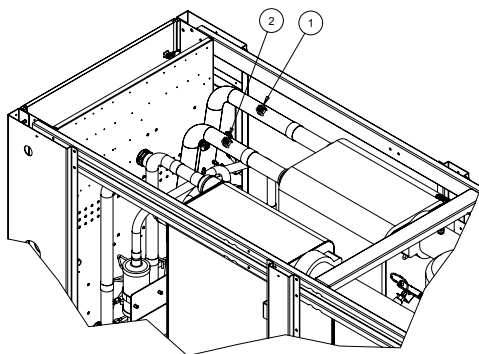

- 1 = Connection for pressure relief valve circuit 1
- 2 = Connection for pressure relief valve circuit 2

Figure 14 - Installing pressure relief valve (212-215)

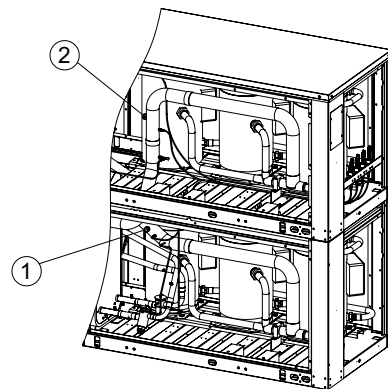

- 1 = Connection for pressure relief valve circuit 1
- 2 = Connection for pressure relief valve circuit 2

Installation

Winter freeze protection

During negative ambient air temperature chilled water piping must be fully insulated. Ensure that all safeties are taken to prevent frost damage during negative ambient air temperature. The following systems can be used:

1. Electrical heater mounted on all water piping exposed to negative temperatures.
2. Start chilled water pump during negative ambient air temperature.
3. Add ethylene glycol in the chilled water.
4. Drain water-circuit, however be aware of corrosion process when drained.

Note

If machinery room can be exposed to temperature below 0°C, systems 2, 3 and 4 must be used.

CAUTION:

- There is a risk of freeze-up of the evaporator circuit due to internal refrigerant migration if the condenser circuit is maintained at a low temperature (below 0°C) for a long period during the cold season. If necessary, provide isolation valves on the condenser water circuit (CGWN). CCUN is protected against refrigeration migration by a liquid solenoid valve.
- When using the freeze protection by pump activation during the cold season, water must be able to circulate freely. Check that no closure valve on other device might block waterflow.

Loading concentrated glycol in the water loop at the suction side of the pump is prohibited. It can severely damage the mechanical seal of the pump and consequently generate potential water leaks.

Figure 15 - Freezing point versus ethylene glycol percentage

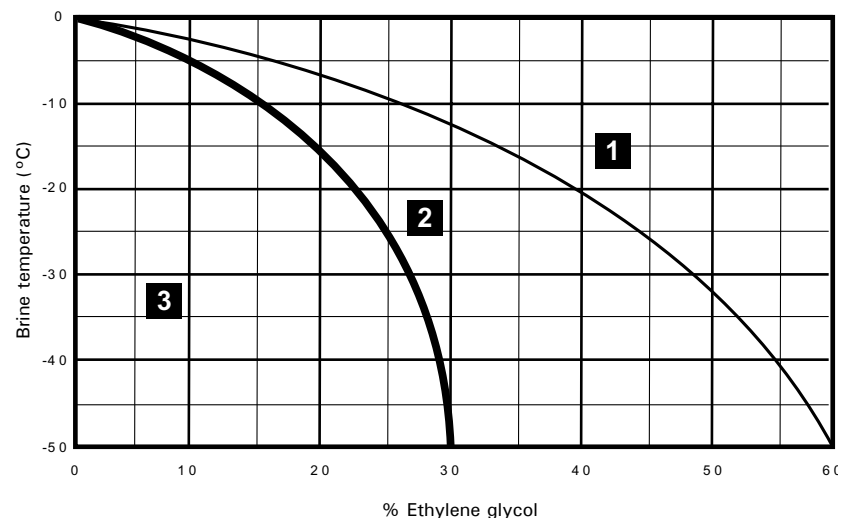

1. Liquid
2. Freezing without burst effect
3. Freezing with burst effect

Installation

Electrical connections

CAUTION:

1. The greatest care should be taken when cutting through passages and installing electric wiring. Under no circumstances should chips of metal or cuttings of copper or isolating material fall into the starter panel or electric components. Relays, contactors, terminals and control wiring should be covered and protected before power supplies are connected.
2. Install power supply cabling as shown in wiring diagram. Adequate cable gland should be chosen, ensuring no foreign bodies enter the electrical housing or components.

CAUTION:

1. Cabling must comply with local standards. The type and location of fuses must also comply with standards. As a safety measure, fuses should be visibly installed, close to the unit.
2. Only copper wiring should be used. Using aluminium wires can produce galvanic corrosion and possibly lead to superheat and failure of connection points.

Soft starter recommended setting

Acceleration time: 0.5 seconds full speed

Start-up torque: 50%

Deceleration time: 0 seconds

Use adjustment setting button.

Figure 16 - CGWN and CCUN main power supply connection (1) (205-211)

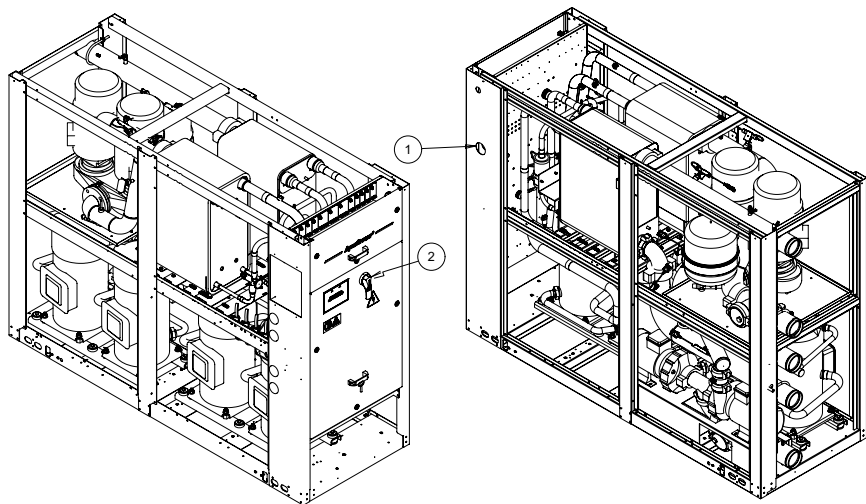

1 = Power cable inlet

2 = Disconnect switch

(1) shown here : CGWN. Components in same location on CCUN.

Installation

Figure 17 - CGWN and CCUN main power supply connection (1) (212-215)

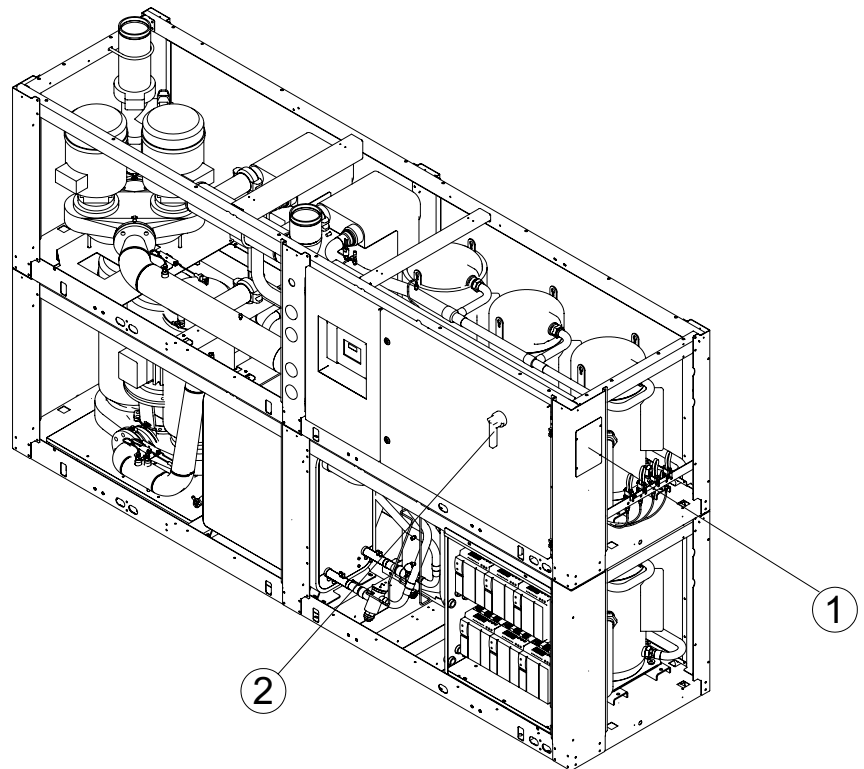

- 1 = Power cable inlet
- 2 = Disconnect switch
- (1) shown here : CGWN. Components in same location on CCUN.

Installation

When ordered, the outdoor air temperature sensor and associated electronics are factory-mounted and wired in the control panel of the chiller. This sensor has to be installed outdoors to allow for proper

operation of the chiller. The wiring of the sensor has to be performed with a 2 wires cable of 0.75 to 1.5 mm² type H05WWF or equivalent. The maximum length of this cable is 305 m. (see Figure 18). The IPC bus is factory-wired.

Figure 18 - Outdoor ambient air sensor connection (self-thread screw)

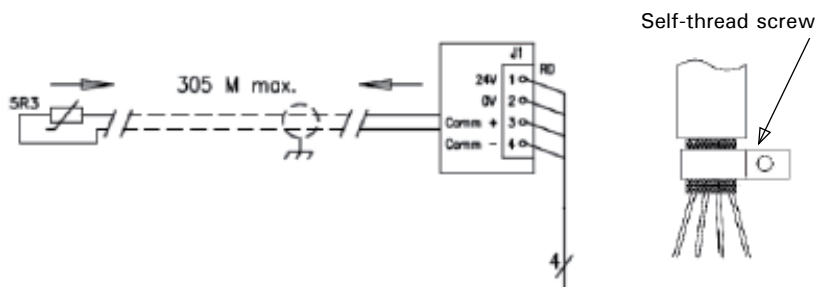
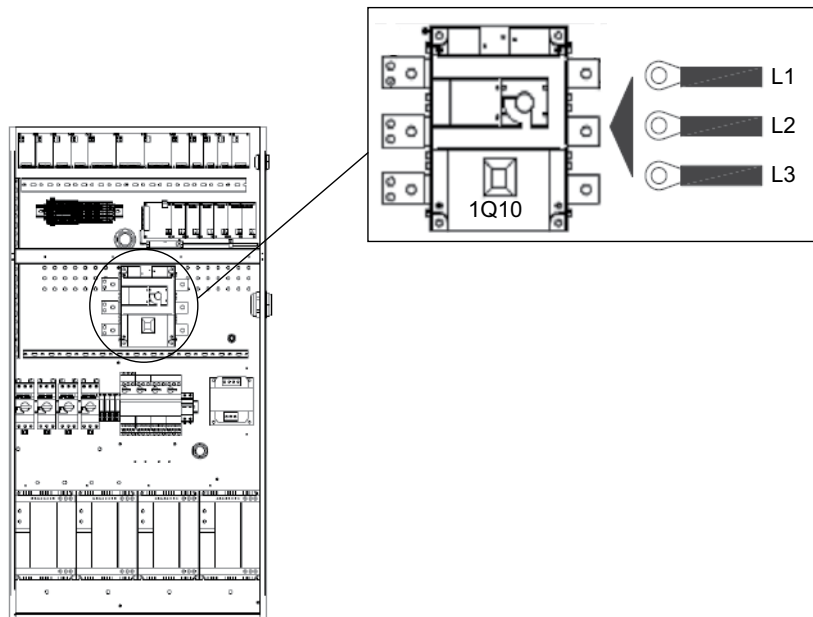
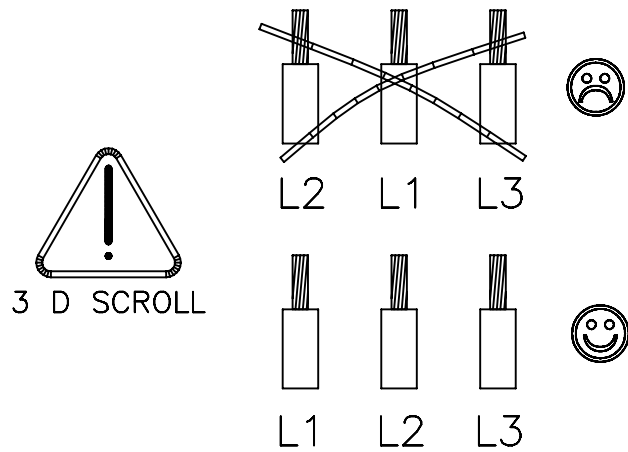
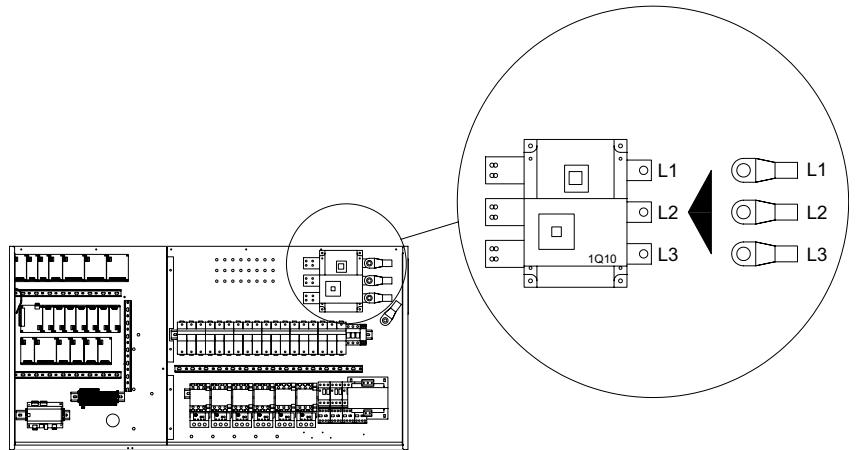

Figure 19 - CGWN and CCUN main power supply connection (205-211)



Installation

Figure 20 - CGWN and CCUN main power supply connection (212-215)



Note Make sure phase order is correct. Should the compressor be noisy, reverse 2 phases.



Installation

Interconnection between CCUN and Remote Condenser

The CCUN has the capability to control the fan staging of the remote condenser if the option is taken. Each refrigerant circuit can control from one up to 6 fans per circuit using a 4 output relays (10A/250VAC/AC1/SPDT) card option provided in the control box of the CCUN. The external wiring to the remote

condenser shall be connected directly to the terminal block for the optional fan relay cards.

CAUTION:

Power supply to the outdoor fan relays shall not be provided from the CCUN unless special care to the Voltage and to the power consumption was evaluated.

Table 16 - Control output relays

Output relay	Fan 1		Fan 2	Fan 3	Fan 4	Fan 5	Fan 6	Fan Option
	Low Speed	High Speed						
2	1&4		3					Two fan speed first fan
								Single speed only fans
3	1	2	3	4				Two fan speed first fan
	1		3	4				Single speed only fans
4	1	2	3	4	4			Two fan speed first fan
	1		3	4	4			Single speed only fans
5	1	2	3	4	4	4		Two fan speed first fan
	1		3	4	4	4		Single speed only fans
6	1	2	3	3	4	4	4	Two fan speed first fan
	1		3	3	4	4	4	Single speed only fans

Table 17 - Fan staging - Example : 4 fans per circuit, single speed

Stage	Number of Fans	Standard - 4 fans per circuit Relays Energized				Capacity [%]
		1	2	3	4	
0	0	0	0	0	0	0.00
1	1	1	0	0	0	25.00
2	2	1	0	1	0	50.00
3	3	0	0	1	1	75.00
4	4	1	0	1	1	100.00

Table 18 - Fan staging - Example : 4 fans per circuit with first fan 2-speed

Stage	Number of Fans	Low Ambient 2 Speed 4 fans per circuit Relays Energized				Capacity [%]
		1	2	3	4	
0	0	0	0	0	0	0.00
1	0.5	1	0	0	0	12.50
2	1	0	0	1	0	25.00
3	1.5	1	0	1	0	37.50
4	2	0	0	0	1	50.00
5	2.5	1	0	0	1	62.50
6	3	0	0	1	1	75.00
7	3.5	1	0	1	1	87.50
8	4	0	1	1	1	100.00

Installation

Operating range

CAUTION: Maximum operating time for low condensing water outlet is 1 minute. The compressor shall become noisy.

The envelope represents the operating range in which the unit will work without control limitation. To keep the unit operating in this envelope, be careful to adjust setpoints inside with a clearance equal to half the dead band.

Check also compressor suction superheat for being close to 5 or 6°C for low chilled leaving water temperature to minimize compressor discharge temperature. For very high leaving condensing water temperature above 55°C, the refrigerant charge can be minimized by 20%.

Figure 21 – CGWN operating limits (180 kW-350 kW)

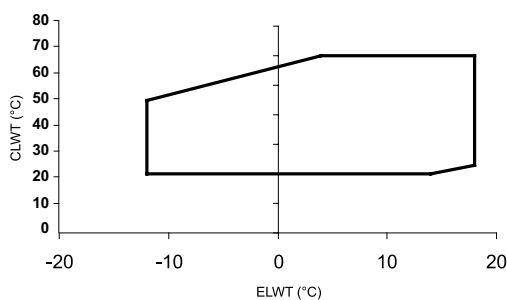

CLWT: Condenser Leaving Water Temperature
ELWT: Evaporator Leaving Water Temperature

Figure 22 – CCUN operating limits (180 kW-350 kW)

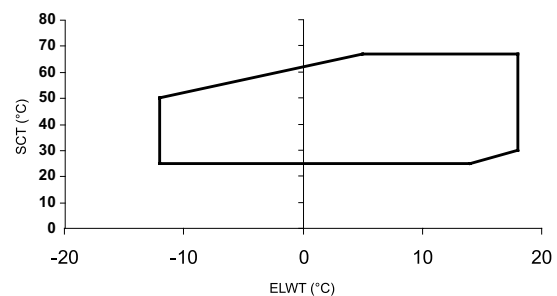

SCT: Saturated Condensing temperature
ELWT: Evaporator Leaving Water Temperature

Figure 23 – CGWN operating limits (350 kW-500 kW)

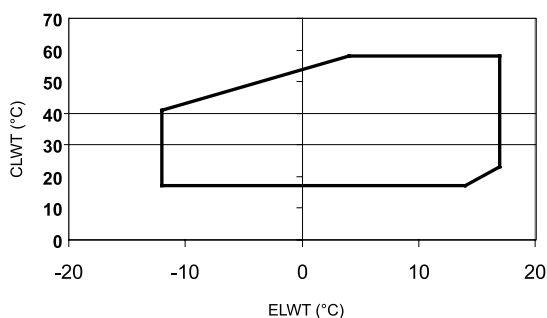

CLWT: Condenser Leaving Water Temperature
ELWT: Evaporator Leaving Water Temperature

Figure 24 – CCUN operating limits (350 kW-500 kW)

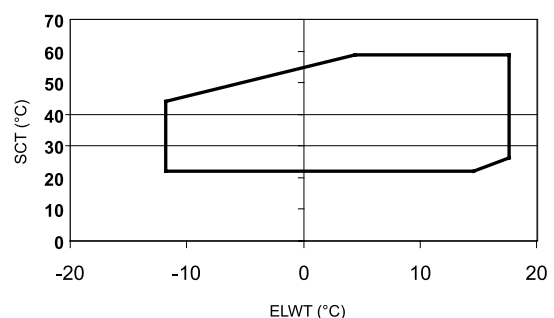

SCT: Saturated Condensing temperature
ELWT: Evaporator Leaving Water Temperature



Installation

Preparation for start-up

Carry out all operations on check list so that the unit is correctly installed and ready to operate. The installer must check all the following points before calling in the Trane Servicing Department to put the equipment into service:

- Check position of the unit
 - Check unit is level
 - Check type and position of the rubber pads
 - Check clearance required for maintenance (Refer to certified drawings)
 - Check clearance around condenser access if split installation (CCUN + remote condenser - Refer to certified drawings)
 - Chilled water circuit ready to operate, filled with water, pressure test carried out and air purged
- CAUTION!** It is prohibited to start the water pumps when the water loop is not filled with water. Doing this can severely damage the mechanical seal of the pump.
- Chilled water circuit must be rinsed
 - Check the presence of water strainer ahead of evaporator
 - The strainers must be cleaned after 2 hours of pumps operation
 - Check the thermometers and manometers position
- Check chilled water pumps interconnection to control panel
 - Ensure that the isolation resistance of all power supply terminals to ground complies with standards and regulations in force
 - Check that unit voltage and frequency supplied match rated input voltage and frequency
 - Check that all electrical connections are clean and sound
 - Check that main power supply switch is sound
 - Check Ethylene glycol or Propylene glycol concentration in the chilled water circuit
 - Water flow control checking: decrease the water flow and check the electrical contact in the control panel
 - Check chilled water pressure drop through evaporator (unit without hydraulic module) or unit available pressure (unit with hydraulic module) are in accordance with the Trane order write-up.
 - On start-up of each motor in the system, check the direction of rotation and operation of all the components they drive
 - Check that there is sufficient demand for cooling on the day of start-up (around 50% of nominal load)



General Start-up

Start-up

Follow the instructions below to correctly start-up the unit.

Installation and chiller inspection

- Ensure that all the operations above (start-up preparation), are followed
- Follow the instruction stuck inside the electrical cabinet
- Put the plexiglass supplied by Trane in front of the power terminal
- Ensure all water and refrigerant valves are in service positions
- Ensure that the unit is not damaged
- Ensure that sensors are properly installed in their bulb-wells and submerged in heat conducting product
- Check fixing of capillary tubes (protection from vibration and from wear) and ensure that they are not damaged
- Reset all manually set control devices
- Check refrigerating circuits tightness

Checking and setting

Compressors:

- Check oil level at rest. The level should reach at least the minimum oil level on the indicator located on oil equalization line (see figure 30) when the compressors have been OFF for 3 minutes for a packaged unit (CGWN) and after 10 minutes OFF time for a split unit (CCUN with remote condenser). See the "Compressor oil level at oil equalization line for correct level.
- Check fixing of capillary tubes (protection from vibration and from wear) and ensure that they are not damaged
- Reset all manually set control devices
- Check refrigerating circuits tightness
- Check electrical terminals tightening of the motors and in the control panel
- Check the isolation of the motors, using a 500V DC megohmmeter which meets manufacturer's specifications (minimum value 2 megohms)
- Check the direction of the rotation using phasemeter

CAUTION! Improper power phasing may result in equipment damage due to reverse rotation.

General Start-up

Electrical power wiring:

- Check all the electrical terminals are tight
- Set-up compressors overload relays
- Set-up fan-motors overload relays

Electrical control wiring:

- Check all the electrical terminals are tight
- Check all the pressostats
- Check and set-up the TRACER CH530 control module
- Test and start-up without the electrical power

Condenser:

- Check setting of the safety pressure valve
- Check the insulation of the motors using a 500V DC megohmmeter which meets manufacturer's specifications (minimum value 2 megohms)

Operating parameters statement

- Switch on main power supply switch
- Start the water pump(s) and check there is no cavitation
- Start-up the unit following procedure described in the CGWN-CCUN User Manual. The unit and the chilled water pumps contactor must be connected together.

After unit start up, leave in operation for at least 15 minutes, to ensure pressures are stabilized. Then check:

- voltage
- compressors currents
- leaving and return chilled water temperature
- suction temperature and pressure
- ambient air temperature
- blowing air temperature
- discharge pressure and temperature
- liquid refrigerant temperature and pressure

Figure 25 - Compressor oil level at oil equalization line

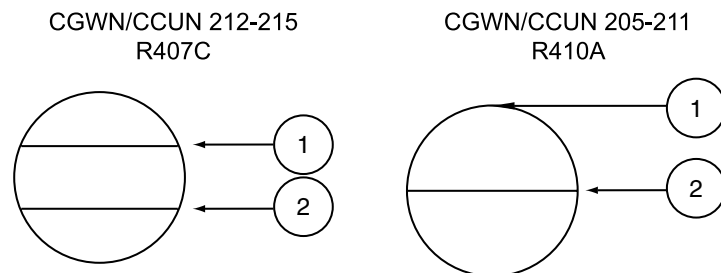

1. Max. oil level
2. Min. oil level

General Start-up

Operating parameters:

- chilled water pressure drop through evaporator (if no hydraulic module is installed) or unit available pressure. It must be in accordance with Trane order write-up.
- superheat: difference between suction temperature and dew point temperature. Normal superheat should be within 5 and 7 °C.
- sub-cooling: difference between liquid temperature and bubble point temperature. Normal subcooling should be within 2 and 10°C.
- Condenser approach: difference between dew point temperature in high pressure and condenser air inlet temperature. Normal value on standard unit, should be 15 to 23°C at full load.
- Evaporator approach: difference between outlet water temperature and dew point temperature in low pressure. Normal value on standard unit, without Ethylene glycol in chilled water, should be between 2 and 5°C.
- Do not start-up a motor whose insulation resistance is less than 2 megohms
- Phase imbalance should not be greater than 2%.
- The voltage supplied to motors should be within 5% of the rated voltage on the compressor nameplate.
- Excessive emulsion of the oil in the compressor shows that refrigerant is present in the oil and the result will be that compressor is not lubricated enough. Shut down compressor and wait for 60 minutes for the sump heaters to heat oil and start again. Should this not work, consult Trane technician.
- Excess oil in compressor can damage the compressor. Before adding oil, consult Trane technician. Use only products recommended by Trane.
- The compressors must operate in a single direction of rotation. If refrigerant high pressure remains stable in the 30 seconds after compressor start-up, immediately shut down unit and check the direction of rotation using phasemeter.

Final check

When the unit is operating correctly:

- Check that the unit is clean and clear of any debris, tools, etc.
- Ensure all valves are in operating position.
- Close control and starter panel doors and check panels fixation.

CAUTION

For the warranty to apply, any start-up carried out directly by the customer must be recorded in a detailed report, which must be sent as soon as possible to your local Trane office.

WARNING!

The chilled water circuit may be under pressure. Bring down this pressure before opening up the system to rinse out or fill up the water circuit. Failure to comply with this instruction may cause accidental injury to maintenance personnel. If a cleaning solution is used in the chilled water circuit, the chiller must be isolated from the water circuit to avoid all the damage risks of the chiller and evaporator water pipes.

General Start-up

Figure 26 - Standard and High Efficiency units evaporator pressure drop

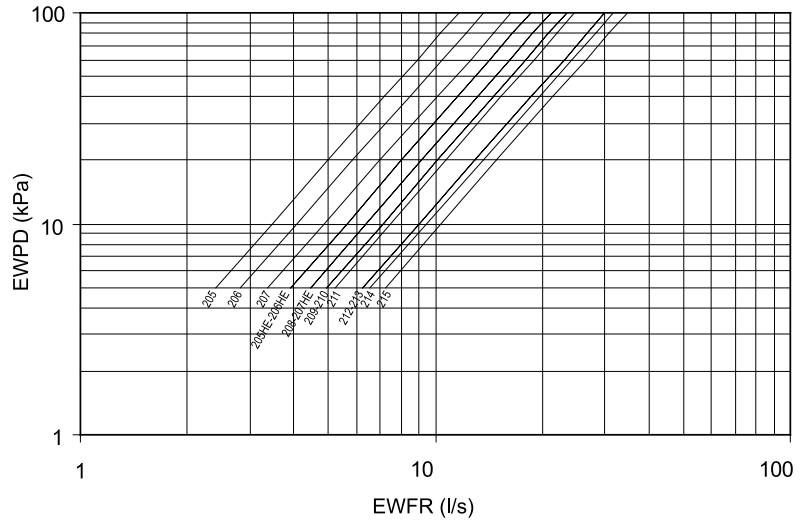

EWFR : Evaporator Waterflow Rate
 EWPD : Evaporator Water Pressure Drop

Figure 27 - Standard units condenser pressure drop

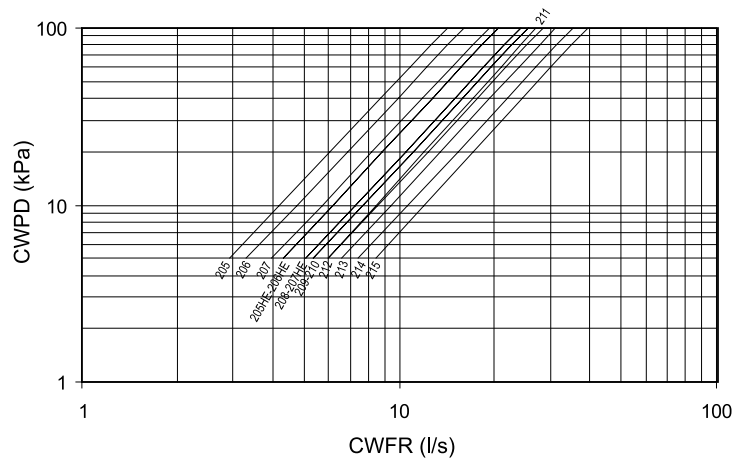

CWFR : Condenser Waterflow Rate
 CWPD : Condenser Water Pressure Drop

General Start-up

Figure 28 - Chiller available pressure - Evaporator side - Standard and High Efficiency units - Low head pressure - Single pump

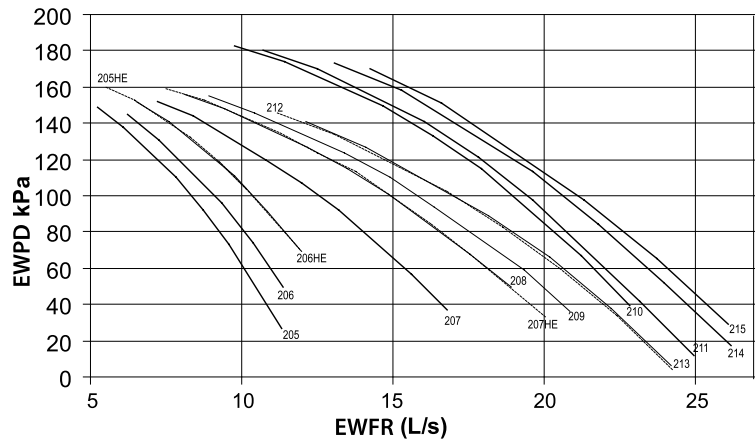

EWFR : Evaporator Waterflow Rate
EWPD : Evaporator Water Pressure Drop

Figure 29 - Chiller available pressure - Evaporator side - Standard and High Efficiency units - Low head pressure - Dual pump

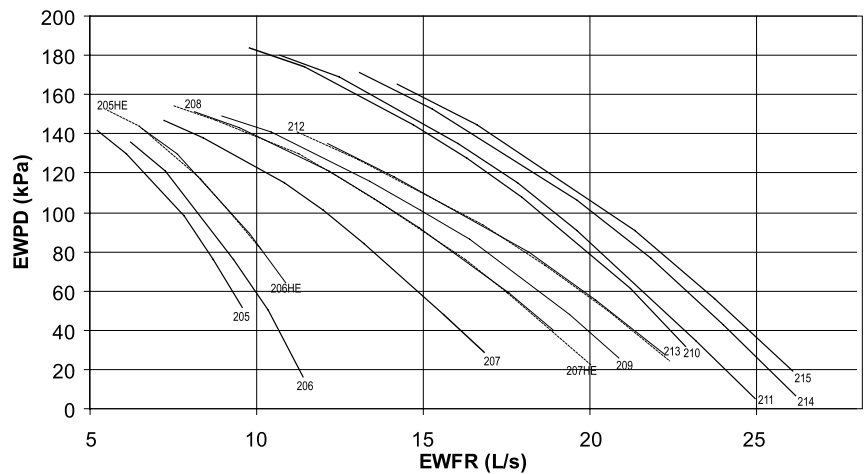

EWFR : Evaporator Waterflow Rate
EWPD : Evaporator Water Pressure Drop

General Start-up

Figure 30 - Chiller available pressure - evaporator side - Standard and High Efficiency units - High head pressure - Single pump

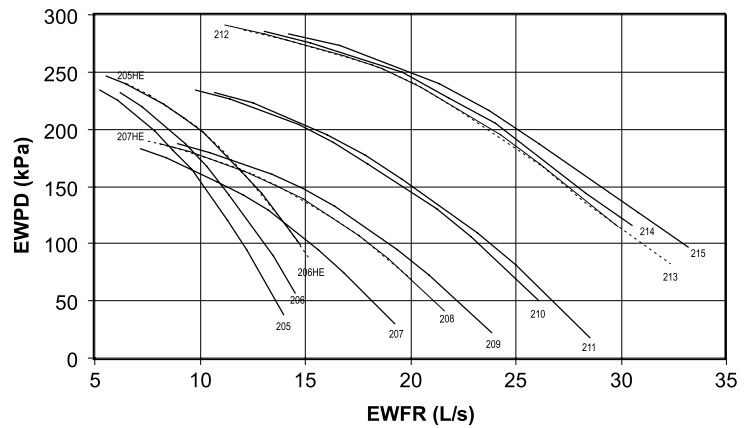

EWFR : Evaporator Waterflow Rate
 EWPD : Evaporator Water Pressure Drop

Figure 31 - Chiller available pressure - evaporator side - Standard and High Efficiency units - High head pressure - Dual pump

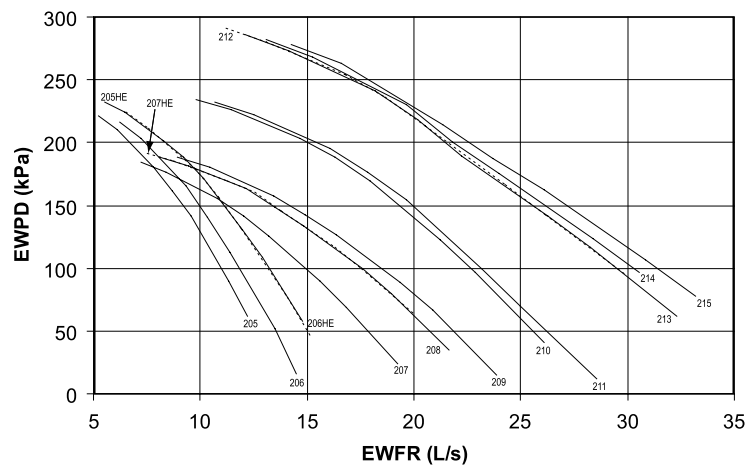

EWFR : Evaporator Waterflow Rate
 EWPD : Evaporator Water Pressure Drop

General Start-up

Figure 32 - Chiller available pressure - condenser side - Standard and High Efficiency units - Low head pressure

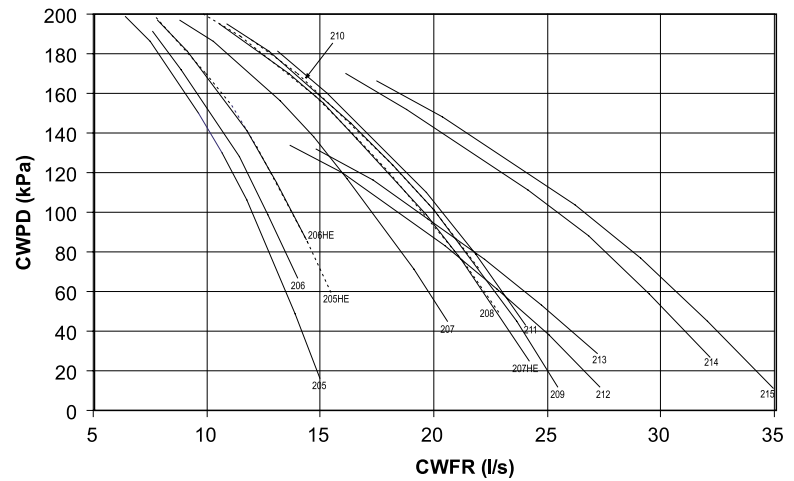

CWFR : Condenser Waterflow Rate
 CWPD : Condenser Water Pressure Drop
 Note: Pumps remain the same when variable speed drive option is selected.

Figure 33 - Chiller available pressure - condenser side - Standard and High Efficiency units - High head pressure

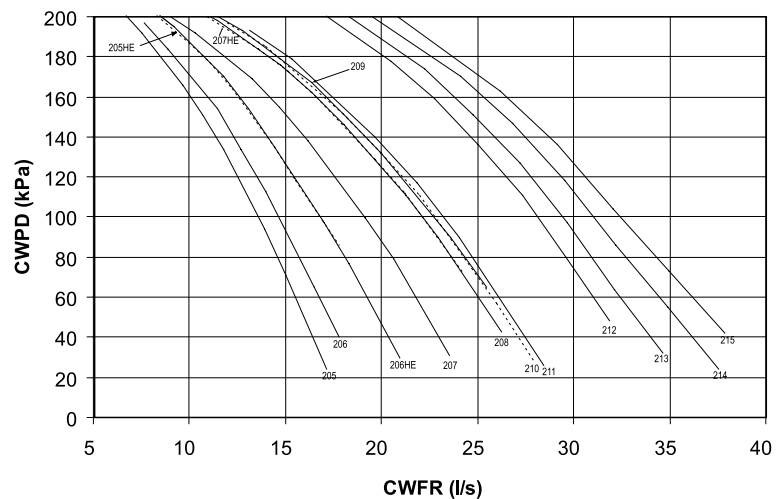

CWFR : Condenser Waterflow Rate
 CWPD : Condenser Water Pressure Drop
 Note: Pumps remain the same when variable speed drive option is selected.

General Start-up

Figure 34 - Chiller available pressure - condenser side - Standard units - Variable speed pump (212-215)

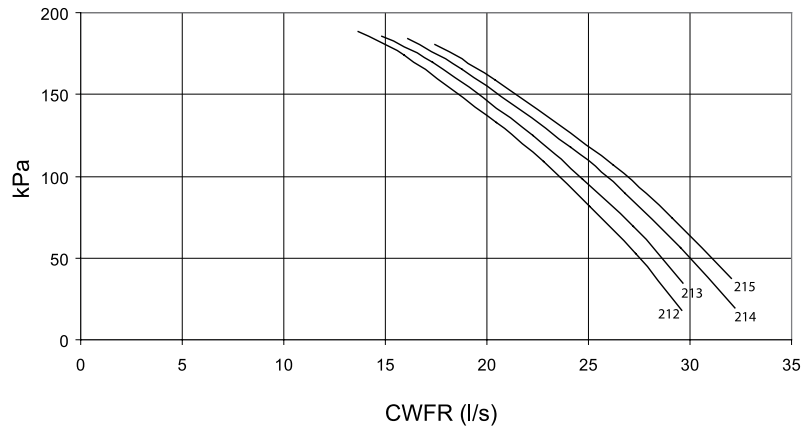

CWFR : Condenser Waterflow Rate
 CWPDP : Condenser Water Pressure Drop

General Start-up

When ethylene glycol is added in the chilled water circuit the following adjustment factors have to be taken in account.

Figure 35 - Ethylene Glycol recommended concentration

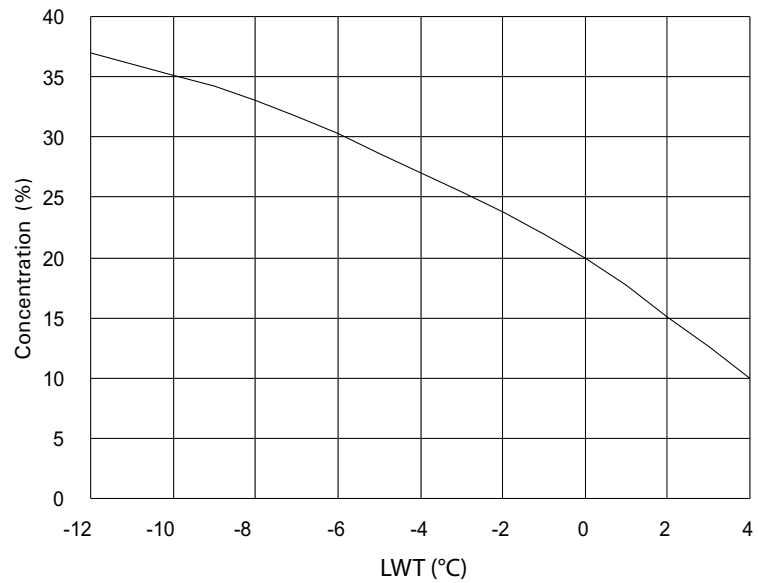

LWT: Lowest water temperature

CAUTION! Loading concentrated glycol in the water loop at the suction side of the pump is prohibited. It can severely damage the mechanical seal of the pump and consequently generate potential water leaks.

Figure 36 - Propylene Glycol recommended concentration

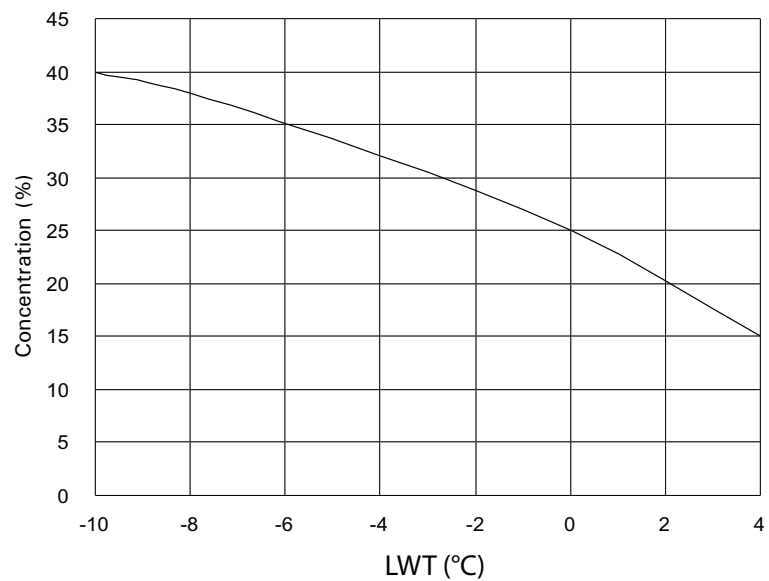

LWT: Lowest water temperature



General Start-up

Table 19 - Correction factors to apply when glycol is used in water loops

Fluid Type	Glycol Concentration %		Performance		Evaporator		Condenser	
	Evaporator	Condenser	F-CC	F-PI	F-FLEVP	F-PDEVP	F-FLCDS	F-PDCDS
Water only	0	0	1.00	1.00	1.00	1.00	1.00	1.00
Ethylene Glycol	10	0	0.99	1.00	1.02	1.02	1.00	1.00
	20	0	0.98	1.00	1.05	1.06	1.00	1.00
	30	0	0.97	1.00	1.10	1.10	1.00	1.00
	0	10	1.00	1.00	1.00	1.00	1.02	1.05
	0	20	1.00	1.01	1.00	1.00	1.04	1.09
	0	30	1.00	1.02	1.00	1.00	1.08	1.14
Mono-Propylene Glycol	10	0	0.99	1.00	1.01	1.05	1.00	1.01
	20	0	0.97	1.00	1.03	1.10	1.00	1.00
	30	0	0.96	1.00	1.05	1.17	1.00	1.01
	0	10	1.00	1.01	1.00	1.00	1.01	1.06
	0	20	1.00	1.01	1.00	1.00	1.02	1.13
	0	30	0.99	1.02	1.00	1.00	1.05	1.21

The correction factors found in the table above can be applied as follows:

- Cooling capacity** with glycol [kW] = **F-CC** x Cooling capacity water [kW] (found in the General data section)
- Power Input** with glycol [kW] = **F-PI** x Power Input water [kW] (found in the General data section)
- Water Flow Evaporator** with glycol [Litres/sec] = **F-FLEVP** x Cooling capacity with glycol [kW] x 0.239 x (1 / Delta T Evaporator [°C])
- Water Pressure drop Evaporator** with glycol [kPa] = **F-PDEVP** x Water Pressure drop Evaporator water [kPa] (refer to the "Standard units evaporator pressure drop" and "HE units evaporator pressure drop" figures.)

In case of application with negative temperature at the evaporator, combination of simultaneous usage of glycol both in evaporator and condenser, or usage of another type of fluid: please contact your local Trane sales representative. A relief valve is located at pump suction limiting water circuit pressure at 3 bar. Nitrogen pressure inside of the expansion tank must be equal to the geometric height of the installation + 0.5 bar (in order to avoid air entering in the water circuit). Expansion tank must be inflated with nitrogen. Pressure must be checked yearly. For a good pump operation, pump suction pressure must be between 0.5 and 2.5 bar when pump runs.

CGWN Only:

- Water Flow Condenser** with glycol [Litres/sec] = **F-FLCDS** x (Cooling capacity with glycol [kW] + Power input with glycol [kW]) x 0.239 x (1 / Delta T Condenser [°C])
- Water Pressure drop Condenser** with glycol [kPa] = **F-PDCDS** x Water Pressure drop Condenser water [kPa] (refer to the "Standard units condenser pressure drop" and the "HE condenser pressure drop" figures)



Operation

Installation checklist

This list must be checked off by the installer to ensure correct installation before the unit start up.

UNIT POSITION

- Check clearance around condenser
- Check clearance required for maintenance access
- Check type and position of rubbers pads
- Check unit is level

CHILLED WATER CIRCUIT

- Check thermometers and manometers presence and position
- Check water flow rate balancing valve presence and position
- Check presence of strainer ahead of evaporator
- Check presence of air-purge valve
- Check rinsing and filling of chilled water pipes
- Check water pump(s) contactor interconnected to control panel
- Check water flow
- Check chilled water pressure drop or unit available pressure (units with hydraulic module)
- Check for leaks in chilled water pipes

ELECTRICAL EQUIPMENT

- Check installation and rating of mains power switch/fuses
- Check electrical connections complied with specification
- Check that electrical connections are in accordance with information on manufacturer's identification plate
- Check direction of rotation using phasemeter

Comments

.....

.....

.....

.....

.....

Signature:.....Name:.....

Order N°:

Work site:

Please return to your local Trane Service Office



Operation

Control and unit operation

The control is through the TRACER CH530 control module.

- Check the chilled water pump(s) operate(s)
- Start up the unit following procedure described in the CGWN-CCUN User Manual. The unit will operate correctly when there is sufficient water flow. The compressors will start up if the evaporator water leaving temperature is above the control module setpoint.

Weekly start up

- Check the chilled water pump(s) operates
- Start up the unit following procedure described in the User Guide.

Weekend shutdown

- If the unit needs to be shut down for a short period of time, stop the unit following procedure described in the CGWN-CCUN User Manual (See "Clock" menu)
- If the unit is shut down for a longer period, see under "Seasonal shutdown", below.
- Ensure that all safety precautions are taken to prevent frost damages during negative ambient temperature.
- Do not put the general disconnect switches to off, except if the unit is drained.

Trane does not recommend draining the unit, due to the fact that it increases tube corrosion.

Seasonal shutdown

- Check water flows and interlocks.
- Check glycol concentration in the chilled water circuit if glycol presence is required
- Carry out leak test.
- Carry out oil analysis
- Record operating pressures, temperatures, amperages and voltage.
- Check operation of machines/ compare conditions of operation against original commissioning data.
- Stop the unit following procedure described in the CGWN-CCUN User Manual.
- Ensure that all safety precautions are taken to prevent frost damages during negative ambient temperature.
- Fill out the visit log sheet and review with the operator
- Do not put the general disconnect switch to off, except if the unit is drained.

Trane does not recommend draining the unit, due to the fact that it increases tube corrosion.

Operation

Seasonal start-up

- Check water flows and interlocks.
- Check Ethylene glycol concentration in the chilled water circuit if glycol presence is required
- Check operational set points and performance
- Calibrate controls
- Check operation of all safety devices
- Inspect contacts and tighten terminals
- Megger the motor compressor windings
- Record operating pressures, temperatures, amperages and voltage
- Carry out leak test
- Check configuration of unit control module
- Change the oil as required based upon results of the oil analysis made during seasonal shutdown.

Get the 8 condition measurements at the same time, on each circuit.

- HP
- LP
- Suction temperature
- Discharge temperature
- Liquid temperature
- Water entering temperature
- Water leaving temperature
- Outdoor ambient temperature

Then calculate the sub-cooling and superheat. No diagnosis can be accurate with one of these records missing.

- Check operation of machines/ compare conditions of operation against original commissioning data.
- Fill out the visit log sheet and review with the operator



Maintenance

Maintenance Instructions

The following maintenance instructions are part of maintenance operations required for this equipment. A qualified technician is needed for regular maintenance as part of a regular maintenance contract.

Carry out all operations as required by schedule. This will ensure long unit service life and reduce the possibility of serious and costly breakdown. Keep service records up to date, showing monthly information on unit operations. These records can be of great help to maintenance personnel diagnostics. Similarly, if machine operator keeps a log of changes in unit operating conditions, problems can be identified and solutions found before more serious problems arise.

Inspection visit after the first 500 hours of operation from unit start up

- Carry out oil analysis
- Carry out leak test
- Inspect contacts and tighten terminals
- Record operating pressures, temperatures, amperages and voltage
- Check operation of machines/ compare conditions of operation against original commissioning data
- Fill out inspection visit log sheet and review with the operator
- Check and clean the strainer
- Check Rotalock tightness with a torque wrench:
 - Compressor suction Rotalock: 190 - 200 Nm
 - Compressor relief Rotalock: 170 - 180 Nm
 - Compressor equalization Rotalock: 170 - 180 Nm

Note: For medium to highly critical applications, a monthly preventive visit is recommended.

Monthly preventive visit

- Carry out leak test
- Oil test of acidity
- Check Ethylene glycol concentration in the chilled water circuit if glycol presence is required
- Inspect contacts and tighten terminals
- Record operating pressures, temperatures, amperages and voltage
- Check operation of machines/ compare conditions of operation against original commissioning data
- Fill out visit log sheet and review with the operator
- Check and clean the strainer



Maintenance

Annual preventive visit

- Check water flows and interlocks
- Check expansion tank pressure
- Check glycol concentration in the chilled water circuit if glycol presence is required
- Check operational set points and performance
- Calibrate controls and pressure transducer
- Check operation of all safety devices
- Inspect contacts and tighten terminals
- Megger the motor compressor windings
- Record operating pressures, temperatures, amperages and voltage
- Carry out leak test
- Check configuration of unit control module
- Carry out oil analysis
- Change the oil as required based upon results of the oil analysis
- Check operation of machines/ compare conditions of operation against original commissioning data
- Fill out the annual start up visit log sheet and review with the operator
- Check and clean the strainer

CAUTION:

- Please refer to specific Trane documentation on oil, available from your nearest Trane office. Oils recommended by Trane have been exhaustively tested in Trane laboratories to the specific requirement of Trane chiller and hence the user's requirements.

Any use of oils not meeting specifications recommended by Trane is the responsibility of the user only, who thereby is liable to warranty loss.

- Oil analysis and oil test acidity must be carried out by a qualified technician. Poor interpretation of results may cause unit operating problems. Also, oil analysis must follow the correct procedures, to avoid accidental injury to maintenance personnel.
- If the condensers are dirty, (Remote condensers) clean them with a soft brush and water. If the coils are too dirty, consult a cleaning professional. Never use high pressure water to clean condenser coils.
- Contact Trane Service for information on maintenance contracts.

WARNING:

Switch off unit main power supply before to any intervention. Failure to follow this safety instruction can lead to injury or death of the maintenance personnel and may also damage equipment.

CAUTION: Never use steam or hot water above 60°C to clean condenser coils (Remote condensers). The resulting increasing pressure could cause refrigerant loss through the safety valve.



Maintenance

Troubleshooting guide

These are simple diagnostic hints, not a comprehensive analysis of the Scroll compressor refrigeration system.

The aim is to give operators simple instructions on basic unit processes so that they have the technical knowledge to identify and bring defective operations to the notice of qualified technician. If there is a breakdown, the Trane Service office should be contacted for confirmation and assistance.

Problems symptoms	Problem causes	Action recommended
A) The compressor does not start up		
Compressor terminals are live but motor does not start.	Motor burned out.	Replace compressor
Contact motor not operational.	Coil burned out or broken contacts.	Repair or replace.
No current ahead of motor contactor.	a) Power cut. b) Main power supply switched off.	Check fuses and connection. See why system tripped. If system is operational, switch on main power supply.
Current ahead of fuse, but not on contactor side.	Fuse blown.	Check motor insulation. Replace fuse.
Low voltage reading on voltmeter.	Voltage too low.	Contact power Supply Utility.
Starter coil not excited.	Regulation circuit open.	Locate regulation device which has tripped out and see why. See instructions concerning this device.
Compressor does not run. Compressor motor "groans". High pressure switch tripped to contacts open on high pressure. Discharge pressure too high.	Compressor sticking (damaged or sticking components). Discharge pressure too high Shut down by thermal overload due to discharge temperature or motor thermal overload	See "Discharge pressure too high". Wait 30 minutes until auto reset of compressor mounted protection. Check superheat versus suction pressure or water temperatures of operation.
B) Compressor stops		
High pressure switch tripped.		
Over current thermal relay tripped.	Discharge pressure too high.	See instructions for "discharge pressure high".
Motor temperature thermostat tripped.	a) Voltage too low. b) Cooling demand too high, or condensing temperature too high.	a) Contact Power Supply Utility. b) See instruction "discharge pressure too high".
Anti-freeze security tripped.	Not enough cooling fluid. Water flow to evaporator too low.	Repair leak. Add refrigerant. Check water flow rate, and flow switch contact in water
C) Compressor stops just after its start		
Suction pressure too low. Filter drier iced up.	Filter drier clogged.	Replace filter drier.
D) The compressor keeps running without stopping		
Temperature too high in areas requiring air-conditioning.	Excess load on cooling system.	Check thermal insulation and air-tightness of areas requiring air-conditioning.
Chilled water temperature output too high.	Excess cooling demand on system.	Check thermal insulation and air-tightness of areas requiring air-conditioning.
E) Loss of oil in compressor		
Oil level too low in indicator.	Not enough oil.	Contact Trane office before to order oil
Gradual fall in oil level.	Filter drier clogged.	Replace filter drier.
Suction line too cold. Compressor noisy	Liquid flows back to compressor.	Adjust superheat and check bulb fixing of the expansion valve.



Maintenance

F) Compressor noisy		
Compressor knocks.	Components broken in compressor.	Change compressor.
Suction duct abnormally cold.	a) Uneven liquid flow. b) Expansion valve locked in open position.	a) Check superheat setting and fixing of expansion valve bulb. b) Repair or replace.
G) Insufficient cooling capacity		
Thermostatic expansion valve "whistles".	Not enough refrigerant.	Check refrigerant circuit tightness and add refrigerant.
Excess pressure drops through filter drier	Drier filter clogged.	Replace.
Excessive superheat.	Superheat not properly adjusted.	Check adjustment of superheat and adjust thermostatic expansion valve.
Insufficient water flow.	Chilled water pipes obstructed.	Clean pipes and strainer.
H) Discharge pressure too high		
Condenser abnormally hot.	Presence of uncondensable liquids in system, or excess refrigerant.	Purge uncondensable fluids and drain off excess refrigerant.
Chilled water leaving temperature too high.	Overload on cooling system.	Reduce load on system. Reduce water flow if necessary.
Condenser air output too hot.	Reduced air flow. Air intake temperature higher than specified for unit	Clean or replace air filters. Clean coil. Check operation of fan motors.
I) Suction pressure too high		
Compressor operates continuously. Suction duct abnormally cold.	Excess cooling demand on evaporator a) Expansion valve too far open.	Check system. a) Check for superheat and check that expansion valve bulb is secure.
Refrigerant flows back to compressor.	b) Expansion valve locked in open position.	b) Replace.
J) Suction pressure too low		
Excessive pressure drop through filter drier. Refrigerant does not flow through thermostatic expansion valve.	Filter drier clogged. Expansion valve bulb has lost its refrigerant.	Replace the filter drier. Replace the bulb.
Loss of power.	Expansion valve obstructed.	Replace.
Superheat too low.	Excessive pressure drops through evaporator.	Check adjustment of superheat and adjust thermostatic expansion valve.
K) Insufficient cooling capacity		
Low pressure drops through evaporator	Low water flow rate.	Check water flow rate. Check state of strainer, check for obstruction in chilled water pipes. Check pressure switch contact in water.



Trane optimizes the performance of homes and buildings around the world. A business of Ingersoll Rand, the leader in creating and sustaining safe, comfortable and energy efficient environments, Trane offers a broad portfolio of advanced controls and HVAC systems, comprehensive building services, and parts. For more information, visit www.Trane.com.

Trane has a policy of continuous product and product data improvement and reserves the right to change design and specifications without notice.

© 2011 Trane All rights reserved
CG-SVX06E-E4 November 01, 2011 Supersedes: CG-SVX06D-E4 December 2009



Digitally printed on environmentally friendly paper;
produced using fewer trees and chemicals and less energy.

