

D4040P

Advanced Solar Charge Controller

Dingo 4040P Reference Manual



Contents

Introduction	4
Additional Installation Notes	4
Features.....	5
Overload Protection.....	5
Thermal Protection	5
Menus	5
1.0 BATV Menu	6
The Regulation Cycle	6
1.1 BOST (Boost)	6
Returning to Boost state	6
1.2 Equalise (optional)	7
1.3 ABSB (Absorption)	7
1.4 FLOT (Float)	7
2.0 CHRG Menu	8
CHRG	8
CINT	8
CEXT	8
Generator Control	8
GSET	9
GMOD	9
GEXD (Generator Exercise).....	9
GDEL (Generator changeover delay)	10
Generator Example	10
3.0 LOAD Menu	12
LOAD	12
LINT	12
LEXT	12
Low Battery Disconnect (LSET, LOFF, LON, LDEL).....	12
4.0 IN Menu	13
IN	13
IN/INT	13
IN/EXT	13
5.0 OUT Menu	13
OUT	13
OUT/INT	13
OUT/EXT	13
6.0 DATA Menu (Retrieving Performance Data)	14
6.1 & 6.2 VMAX & VMIN	14

6.3 FTIM (Float time Display)	14
6.4 SOC (State of Charge Display)	14
6.5 TEMP (External Battery Temperature Sensor Display)	15
Setting Lockout	15
6.6 SOLV (Solar Voltage Display)	15
6.7 HIST (History display)	15
7.0 SET menu	17
7.1 TIME	17
7.2 VOLT	17
7.3 PROG (Adjusting Regulation Settings)	17
Program Function Table (Generic Programs)	17
Program Description	17
Settings Used in Programs 0-3	18
Settings for Program 4	18
7.4 REG menu (Customising Regulation Settings)	19
7.4.1 HYST (Hysteresis Value).....	19
7.4.2 Charge Current Limit	20
7.4.3 TCMP (Temperature compensation)	20
Connecting a Temperature Sensor	21
7.5 MODE Menu (Adjusting Configuration Settings)	22
7.5.1 LSET & GSET Controlling the load and G outputs	22
7.5.2 ESET Controlling external switches.....	24
7.5.3 BSET: Configuring B- Sense Input	24
7.5.4 BAT2 - Second battery control	26
7.5.5 PWM and Slow Switching	27
7.5.6 BCAP Setting battery capacity	28
7.5.7 ALRM Setting an alarm point	28
7.5.8 RSET & DFLT Reseting and setting factory defaults	28
7.6 EVNT Menu (Using the Event Controller)	29
Examples:	32
8.0 Setting up a larger system	33
A.0 Appendices	35
A.1 Accessories	35
A.2 Specifications	35
A.3 The Alarm Led	36
A.4 Current limits & thermal derating	36
A.5 Block Diagram	36
A.6 Mechanical Information	38
Programs 0-3 Menu System & Legal statement on warranty	39
Program 4 Menu System (for custom settings)	40
Settings and History record sheets	41

Introduction

Please read the User Guide before reading this manual.

In most cases, the User Guide provides all the information needed for effective installation of the Dingo, and there is no need for the user to read this Reference Manual.

Some users will require further information. This manual provides a detailed technical description of the operation of the controller. This manual assumes more technical knowledge than the User Guide.

If you are in any doubt, it is recommended you do not adjust the advanced settings described in this manual. Incorrect adjustment may reduce the effectiveness of your Dingo and could damage your battery.

All voltage values used in this manual assume a 12V system. Scale voltages for other system voltages (e.g. 24V system = voltages x 2, 48V system = voltages x 4)

Additional Installation Notes

Ensure that you have followed the installation instructions on pages 3-5 of the User Guide. The Dingo can be used for system voltages up to 48V. It is safe to connect the power before setting the system voltage, even with a 48 volt battery.

Always mount the Dingo vertically with clear airflow around the bottom and top of the case. In hot conditions, do not put it in a sealed enclosure, as this will restrict the airflow around it. Do not install the Dingo in direct sunlight in hot conditions.

Please consult section A.4 to determine the performance that can be expected in hot conditions.

The Dingo is specified for up to 60°C ambient temperature. At full power, in high temperature ambients, the LCD display may occasionally reach a high enough temperature to become darker and may become unreadable. It will return to normal when it cools down.

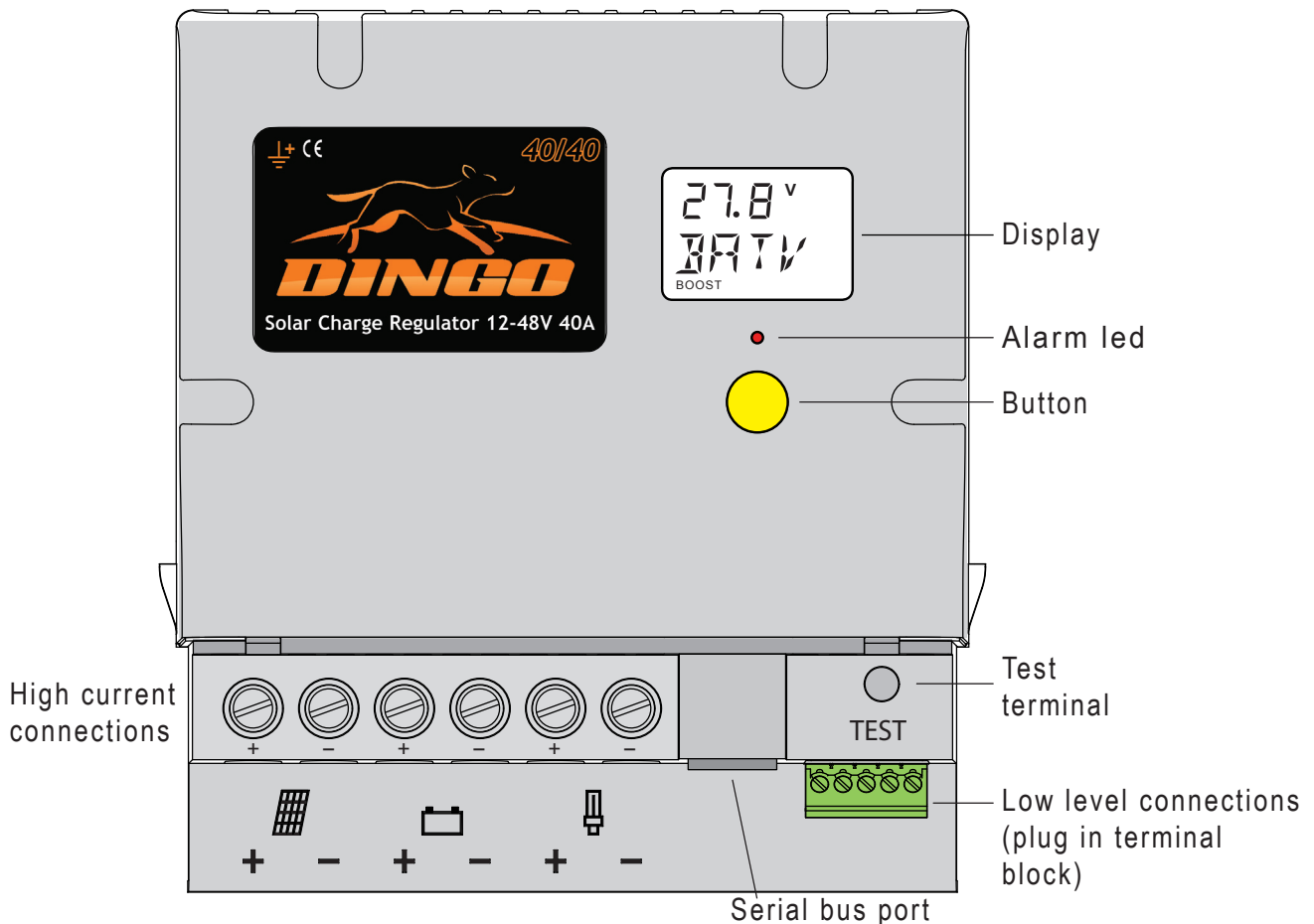

Features

The Dingo series of solar controllers is exceptionally versatile. They give the user unparalleled capability to adjust the function of the controller and to monitor the performance of the energy system.

To cater for non technical users, the Dingo has four preset programs which can be used without needing to understand the details of its operation. For those with a good understanding of solar regulation, there is another program, which allows all the settings to be adjusted if required.

Once the program has been selected, it is possible to disable any further adjustment. This prevents unauthorised adjustment of settings.

Although the Dingo is primarily a device to control the charging of batteries from solar electric (photovoltaic) panels, it can also be used with other energy sources such as wind, microhydro and fuel driven generators.

The Dingo supports a variety of regulation methods. It supports slow speed switching and fixed frequency pulse width modulation (PWM) control in series and shunt modes.

Low battery voltage load disconnection is provided, as are an alarm, facility to control the charging of a second battery bank and control for a back up generator. The event controller can be used to control lights, pumping, waste energy use and other timer functions.

A temperature sensor can be added to correct the regulation voltages for battery temperature.

There is an input for measuring external voltages.

A serial interface is provided for accessories including extra switch blocks, remote current sensors and communication with a computer/modem.

Using an external current shunt attached to a remote current sensor (DSA) allows the controller to see other current flows in the system.

The Dingo can control larger systems by adding external switch blocks attached to the serial bus.

The DUSB, D232 or DNET interfaces allows remote monitoring and adjustment. Custom

settings can be stored on a computer and uploaded into the controller. Data from the controller can be downloaded into the computer and displayed easily.

Overload Protection

The Dingo has overcurrent protection on both the load and charge switches.

If the user accidentally short circuits the load or the charge connections, then the switch will turn off very quickly before any damage is done to the switch.

If the user overloads the load switch, then the load switch will disconnect after a period of time to protect itself from overheating. It will reconnect automatically once the switch cools

If the charge input is overloaded, then the controller will turn the charge switch off, as required, to reduce the average charge current into the Dingo.

For details see section A.4.

Thermal Protection

The Dingo has a temperature sensor on the circuit board. The function of this sensor is to tell the Dingo how hot its own circuit board is so that it can reduce the charge current (the major heating source) in order to protect against overheating.

See section A.4 for details of thermal derating

Menus

The Dingo has a simple main menu. This is described in the user guide and provides most the information required for normal use.

Behind each of the main menu screens are sub menus. These are entered by doing a long push in the main menu. They allow access to more information and control of more advanced features.

The following pages describe each submenu in detail.

1.0 BATV Menu

The BATV screen, shown at power-up, displays the real-time battery voltage.

A long push on the BATV screen will display the state of the charge regulation cycle.

The Battery Charge Cycle

The Dingo's sophisticated regulation system is designed to keep the battery fully charged without overcharging it.

To achieve this, it uses a charge control process with three main states. These states are Boost, Absorption and Float. It also uses a fourth state from time to time, called the Equalisation state (See fig 1B.)

1.1 BOST (Boost)

In the boost state, all the charge current available is used to charge the battery. As the battery charges, its voltage rises. When the voltage reaches the boost maximum voltage (BMAX) and remains there for 3 minutes, the controller will automatically advance to the absorption state and then, later, to the float state.

Returning to Boost state

To get this charge cycle to repeat, the Dingo must return to the boost state. There are three ways that it can do this.

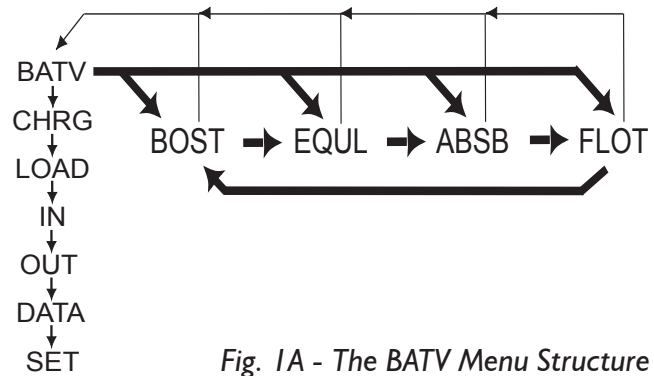

Fig. 1A - The BATV Menu Structure

a. Low Battery Voltage

If the battery voltage falls below the boost return voltage BRTN for more than 10 minutes, then the Dingo will switch back into the boost state. The delay is necessary to prevent large short term loads causing unnecessary returns to Boost.

b. Programmed boost cycles (optional)

The Dingo will automatically do a boost cycle after a set number of days (BFRQ), regardless of battery voltage.

c. Manual boost

The user can manually set the Dingo into the boost state (or any of the regulation states).

To manually advance to the next state, do a long push on BATV. This will show the current regulator state. (BOST=Boost, EQU=Equalise, ABSB=Absorption, or FLOT=Float). A long-push on that state will manually advance into the next state. Or, to return to the BATV screen without changing the state, do a short push.

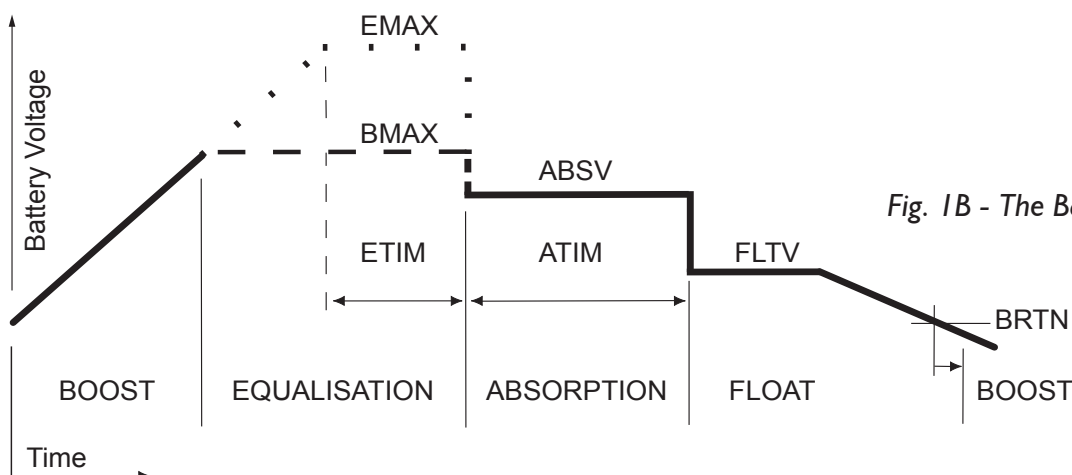

Fig. 1B - The Battery Charge Cycle

Note: if ETIM is 0, then the Equalise state will be bypassed. If ATIM is 0, then the Absorption state will be bypassed.

On the BOST and FLOT displays, the battery voltage is shown. On the EQU and ABSB displays, the time on the equalisation or absorption timer is displayed. When this time reaches the set time (ETIM or ATIM) the Dingo will advance to the next state. Remember that the timers will stop if the voltage falls too far below the set point.

1.2 Equalise (optional)

Many battery manufacturers recommend that the battery bank be given an overcharge occasionally. This is a deliberate overcharge, designed to equalise the voltages and specific gravities of all the cells in the bank by bringing them all up to full charge and to stir up the electrolyte in liquid cells to reduce stratification.

The Dingo supports an automatic programmed equalisation. This state allows the battery voltage to rise until it gets to the equalisation voltage (EMAX) and then remain at this voltage for the set equalisation time (ETIM). This equalisation is done every EFRQ days. (Typically 30-60 days). Equalisation will begin at 9am on the appropriate day. If ETIM is 0, then equalisation will not occur.

To prevent the controller being trapped in equalise mode for a long time because there is inadequate charge current to reach the equalise voltage, the Dingo terminates equalise after 4 days

1.3 ABSB (Absorption)

In this state, the Dingo tries to keep the battery voltage constant while the last part of the battery charging occurs. This prevents excessive gassing which occurs at high cell voltages. The Dingo will keep the battery voltage at the absorption voltage ABSV until it has been at this voltage for the absorption time ATIM. When the absorption time is finished, the Dingo advances to the Float state.

If there is a cloudy period and there is insufficient charge current to keep the voltage up to ABSV, then the absorption timer will stop and resume when the voltage comes back up to ABSV.

To allow some margin, the timer actually runs if the voltage is above ABSV-HYST. (HYST is the hysteresis setting used for slow speed switching - usually about 0.4V)

1.4 FLOT (Float)

In this state, the battery has been fully charged. The charge current is now used to keep the battery voltage at a level which maintains full charge. This voltage (FLTV) should be below the gassing voltage to avoid excessive electrolyte loss. If charge is drawn from the battery, the Dingo will allow charging to resume until the battery returns to FLTV.

Moving around the Menus

You can move around the menu system and change settings using the button on the front of the controller. There are seven top-level menu items in the menu system (BATV, CHR, LOAD etc - see fig 1a). Each menu item provides access to a sub-menu, and some of these sub-menus lead again to further sub-menus.

A **short** push tells the controller to advance to the next menu item or setting value. To do a short push, press the button on the front of the controller, and release it immediately.

A **long** push "selects", moving into a sub-menu or allowing you to change settings. To do a long push, press the button, holding it down until the menu changes (about one second).

To change a setting, long push until number flashes. Short push to adjust. Then long push to save.

Getting back. Wherever you are in the menu system, a series of short pushes will bring you back to the top-level menus. (*except during setting adjustment and when you see the word "EXIT" in the "HISTORY" sub menu - see section 6.7.*)

Reverse. If you overshoot the setting you want and need to go back, you can use reverse. Do a long push. The number stops flashing. Do another long push. The number starts flashing again but this time short pushes will reduce the setting.

Fast Forward. If you do 5 short pushes quickly, you will enter fast forward mode. The settings change in larger steps so you can move quickly.

To return to normal mode, don't push for 1 second.

2.0 CHRГ Menu

CHRГ

The CHRГ screen gives the real-time total charging current (Amps). This total is the sum of solar charge current (CINT) and any external charge current. This may be current from an external switchblock or MPPT device connected to the bus or an external current measured using a current shunt and a DSA.

CINT

From the charge screen, a long push displays CINT (Charge Internal). This is the real-time solar charge current flowing into the SOL-terminal. (measured in amps.)

External Charge

From the CINT screen, a short push displays the current reading from any external device attached which can measure current. If the device is a maximum power point tracker (MPPT) then this device is shown as MPTx,

where x is the device number. Similarly, for switchblocks the display is SWHx and for shunt adaptors, SHNx. The device number can be from 1 to 4 for shunt adaptors and from 1 to 12 for MPPT or Switchblocks. To fit the display, numbers greater than 10 are given letters. So 10 is A, 11 is b and 12 is C.

This list also allows the user to check that the Dingo has found or 'discovered' all the external devices attached to the bus. This discovery process is automatic. If a device is not on the list and should be, then refer to section 8.4 for troubleshooting advice.

Generator Control

The Dingo has a comprehensive generator controller built in. It works in a similar way to the Low Battery Disconnect function. It is designed to give a run or stop signal to an electronic start generator. It does not handle the actual generator start-up sequence - this should be done by the generator itself.

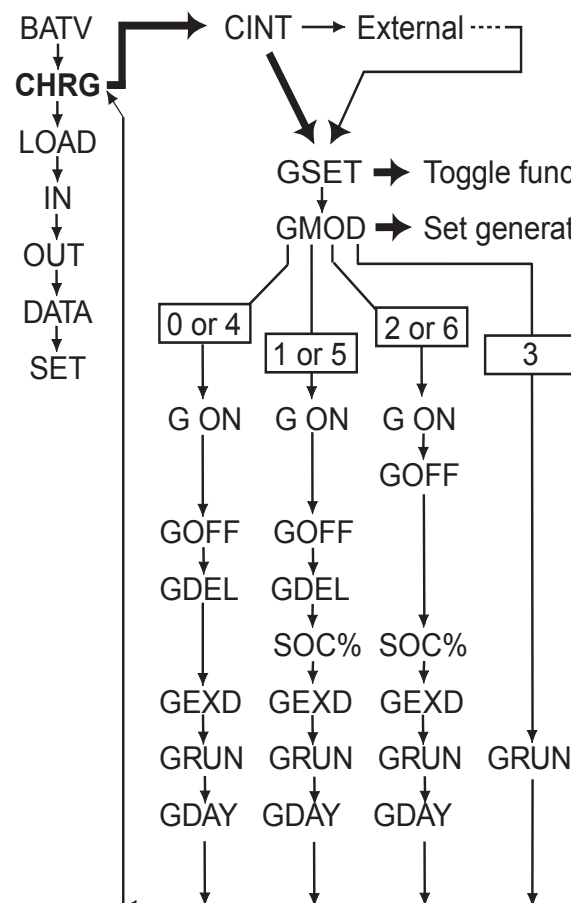

Fig. 2A - Generator Control Menus (PROG=4 only)

- ➔ Set Voltage / SOC% to start generator
- ➔ Set SOC% to stop generator
- ➔ Set Voltage to stop generator
- ➔ Set delay before on/off change
- ➔ State Of Charge (SOC) *Long push to adjust*
- ➔ Set days between generator exercises
- ➔ Set length of generator exercise
- ➔ View/change number of days since last exercise (or run time if generator running)

GSET

In the GSET screen, a long push will manually change the state of the generator output. The GEN indicator at the bottom of the screen is visible when the generator function wants the generator to be running. Note: the Generator will not turn on during the 'quiet time', if selected. (see below)

GMOD

The generator can operate in four different modes. The generator mode is selected in the GMOD screen and can be 0-6.

Quiet time: In modes 0,1 & 2, the generator is not allowed to start between 9pm and 9am so as to enforce a 'quiet time'.

Modes 4-6 are the same as modes 0-2 except that there is no quiet time.

Note - do not confuse the GSET described in Figure 2A with the screen of the same name described in Section 7.5.2. which sets the G terminal function.

GEXD (Generator Exercise)

To prevent the generator from seizing up, it is good practice to exercise the generator periodically. The Dingo supports this with an

Mode#	Description
0.	Turn on when battery voltage falls to G ON for GDEL minutes. Turn off when the voltage rises to GOFF for GDEL minutes. Quiet time applies.
1.	Turn on when the State of Charge (SOC%) falls to G ON % of the battery capacity. Turn off when the voltage rises to GOFF for GDEL minutes. Quiet time applies.
2.	Turn on when SOC % falls to G ON%. Turn off when SOC% rises to GOFF%. Quiet time applies.
3.	Manual start. When started (in the GSET screen) the generator will run for GRUN hours.
4.	No quiet time. Turn on when battery voltage falls to G ON for GDEL minutes. Turn off when the voltage rises to GOFF for GDEL minutes.
5.	No quiet time. Turn on when the State of Charge (SOC%) falls to G ON % of the battery capacity. Turn off when the voltage rises to GOFF for GDEL minutes.
6.	No quiet time. Turn on when SOC % falls to G ON%. Turn off when SOC% rises to GOFF%.



GMOD:	Quiet Time			M*	No Quiet Time			Name	Description	Range
	0	1	2	3	4	5	6			
	•				•			GON	Set V to start generator	10-12.5V
		•	•			•	•	GON	Set SOC% to start generator	0-99%
	•	•			•	•		GOFF	Set V to stop generator	11.0-16.5V
			•				•	GOFF	Set SOC% to stop generator	1-100%
	•	•			•	•		GDEL	Set delay before on/off change	1-15 min
		•	•			•	•	SOC%	Current SOC% Long push to adjust	0-100%
	•	•	•		•	•	•	GEXD	Set days between generator exercise	2-60 days
	•	•	•	•	•	•	•	GRUN	Set length of generator exercise	0-4.0 hrs
	•	•	•		•	•	•	GDAY	View/change # of days since last exercise	2-60 days

• = Active Parameter for relevant generator mode (GMOD)

*M = Manual

GMOD = GMOD Settings

automatic generator exercise function, which will turn on every GEXD days. The number of days since the last exercise is shown on the GDAY screen. The generator will run for GRUN hours. When exercising, the elapsed time is shown as GTIM. Both GDAY and GTIM can be adjusted.

Note:

1. There is no generator exercise when GMOD = 3 (manual start).
2. GSET toggle does not work during generator exercise
3. A small amount of overcharge will occur if battery is already fully charged. Use a low GRUN value if this is of concern.

GDEL (Generator changeover delay)

A programmable delay (in minutes) is used to prevent false turn on or off of the generator due to large transient loads. Default setting is 10 min.

The generic programs (PROG=0-3) use voltage driven generator control (GMOD=0). See "settings used in Programs 0-3" for on-off voltages etc.

Generator Example

For example, if SOC% triggered generator on, voltage-triggered generator off, and no quiet time, is desired, set up the regulator as follows:

PROG = 4	Allows user adjustment.
GMOD = 5	SOC % ON, Voltage OFF, no quiet time
CHRG menu :	Set GON, GOFF, GDEL, GEXD, GRUN as required
SET/REG :	Check these settings are correct for your battery type
Mode menu :	GSET if using 'G' terminal for generator control or LSET if using LOAD terminal for generator control

Note: when changing from prog 0-3 to program 4, the user can load the default settings for program 1 into the Dingo using the DFLT screen in the MODE menu. See section 7.5.8. This can save a lot of time.

Generator Control

For many generators it is possible to control their operation remotely. This is either a remote start or run function built into the generator or a separate remote start unit.

There is usually a pair of contacts that will cause the generator to run if they are closed. This can be done with a switch or a relay.

The Dingo provides a G relay which can be used for this purpose. This relay is voltage free and solid state. It can carry a current of up to 300mA and can block 85V.

For some generators it is possible to connect the G relay directly to the remote start input on the generator. The wiring for this is shown in fig 2B.

Fig. 2B - Generator start relay wiring

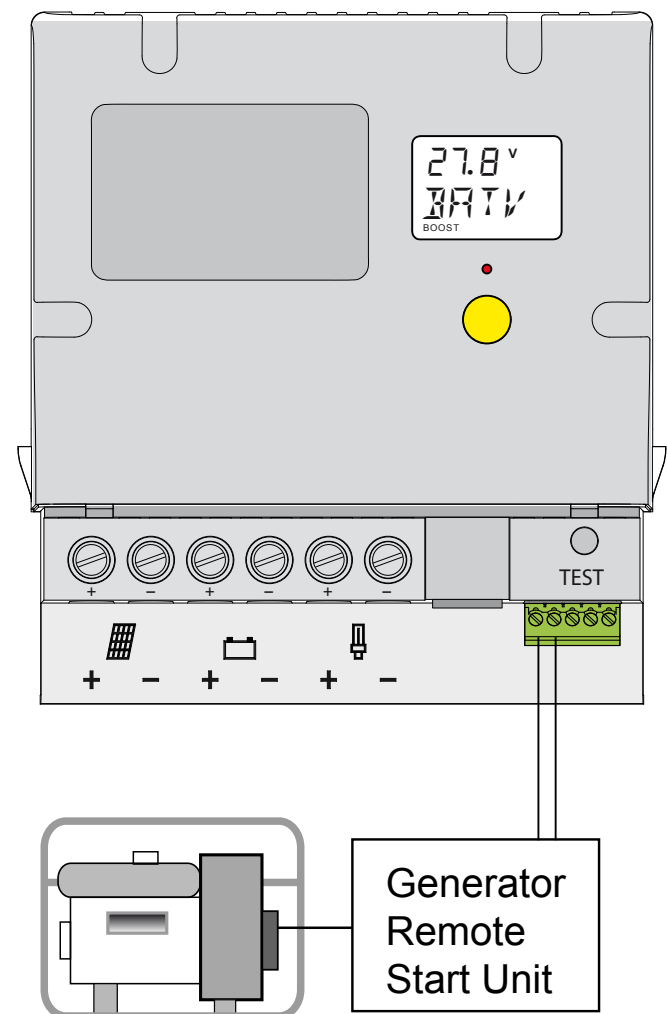

Generator controlled directly by the G relay

This direct connection will work if the current flowing through the remote start terminals is less than 300mA. If the current is greater than this, then it will be necessary to use an intermediate relay with a higher contact current rating. The G relay switches the intermediate relay which in turn switches the remote start terminal. The wiring for this is shown in fig 2C.

Choose a relay with a contact current rating suitable for the remote start unit and a coil voltage which is the same as the system voltage. The relay coil should not draw more than 300mA when it is energised. Be careful with automotive relays because they can often be poor relays requiring large coil currents. Use relays from the electronics industry which generally have lower drive power.

The G relay terminals do not need a catch diode across the relay coil to protect from the flyback voltage. This protection is built into the G terminal.

It can be difficult to determine what current is required to operate the remote start. The best way to do this is to measure it. Short the remote start terminals with a multimeter on its current range and measure the current.

The manufacturer's manual should contain this information but often does not.

The generator control provided by the Dingo is simple - a contact closure is provided when the generator should run and the contacts open when the generator should be stopped. It does not handle the issues associated with starting such as fuel and what to do if the generator does not start. This should be handled by the remote start unit.

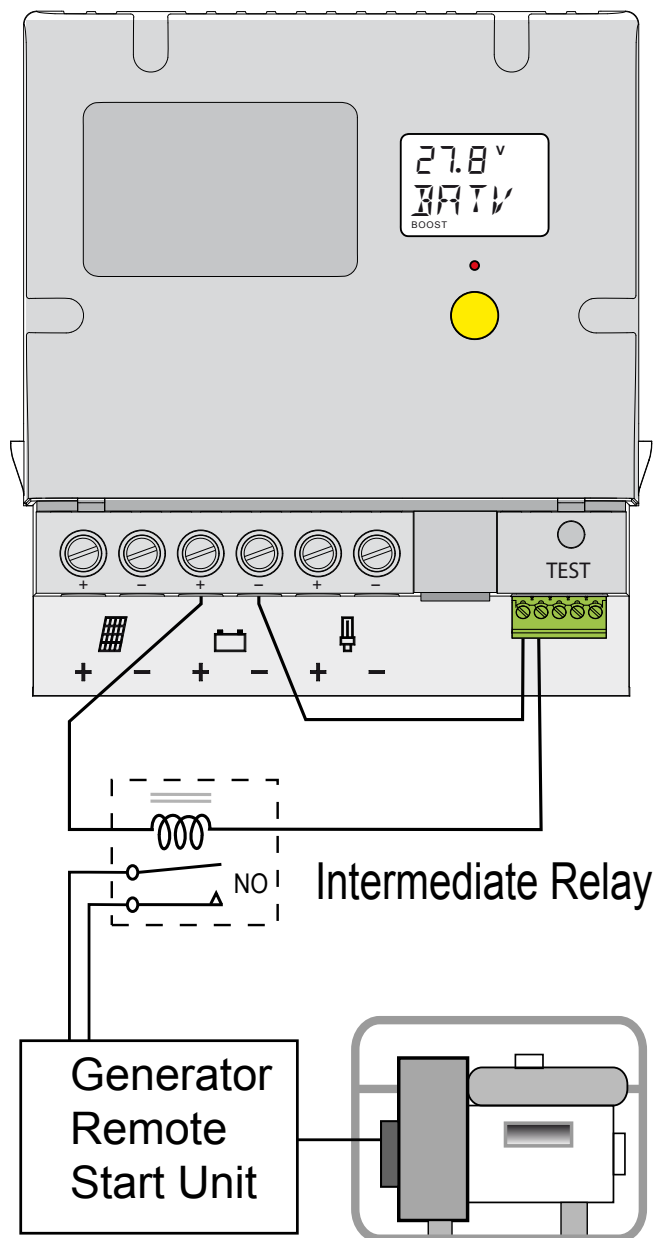

G relay switches a larger relay

Fig. 2C - Generator start wiring with an intermediate relay.

3.0 LOAD Menu

LOAD

The LOAD screen gives real-time total load current (in Amps). This total is the sum of the current flowing through the load terminal (LINT) and any external load current. This may be current from an external switchblock or an external current measured using a current shunt and a DSA.

LINT

From the LOAD screen, a long push displays LINT (Load Internal). This is the real-time load current used by equipment connected to the regulator's LOAD terminal.

External Load

From the LINT screen, a short push displays the load current reading from any external device attached which can measure current. If the device is a maximum power point tracker (MPPT) then this device is shown as MPTx, where x is the device number. Similarly, for switchblocks the display is SWHx and for shunt adaptors, SHNx. The device number can be from 1 to 4 for shunt adaptors and from 1 to 12 for MPPT or Switchblocks. To fit the display, numbers greater than 10 are given letters. So 11 is A, 12 is B and 13 is C.

This list also allows the user to check that the Dingo has found or 'discovered' all the external devices attached to the bus. This discovery process is automatic. If a device is not on the list and should be, then refer to section 8.4 for troubleshooting advice.

Name	Description	Range
LOFF	Set voltage at which load disconnects	10.0-12.5 V
LON	Set voltage at which load reconnects	11.0-16.0 V
LDEL	Set delay before switching on/off	0-15 min

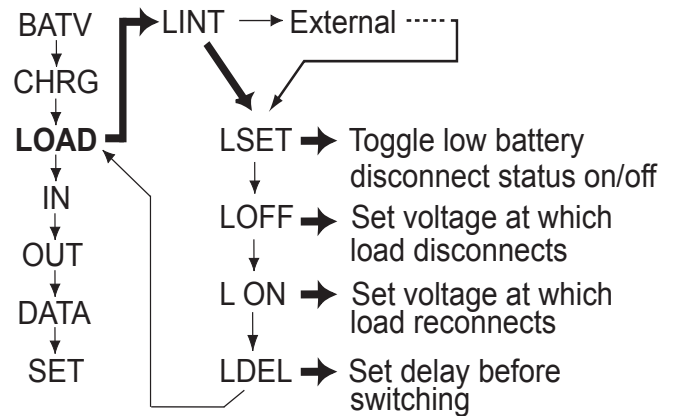

Fig. 3A - LOAD Menu

Low Battery Disconnect (LSET, LOFF, LON, LDEL)

To prevent battery damage due to over-discharge, the Dingo has a function which turns off the load if the battery voltage falls too low.

If correctly configured, equipment connected to the Load- terminal (the "load") will be turned off when the battery voltage falls below the LOFF voltage for LDEL minutes. Once turned off, the load will not be reconnected until the voltage rises above the L ON voltage for LDEL minutes. The L ON voltage should be set high enough so that some recharge will have taken place before reconnection, otherwise the disconnection process can oscillate.

This feature is optional, and can be disabled either by connecting the user load directly to the battery, or by setting LOFF low enough so that the low battery disconnect function never activates.

The LOAD indicator at the bottom of the screen is visible when the low battery disconnect function wants to disconnect the load. (Note that other settings can override the function, so the LOAD indicator does not necessarily mean that power has actually been disconnected from the load.) When the disconnect timer has begun to timeout, the alarm led will flash at a 2 second rate with the led mostly on. If the load disconnect function operates, then the alarm led continues flashing but with the led mostly off.

The Low Battery Disconnect function can also be toggled manually by a long push when in LSET menu (see Figure 3A).

Selecting a load switch

The low battery disconnect is an internal logical function. To do something other than act as a warning, it has to be used to control a load switch.

This can be done in three different ways. It can control the Dingo’s LOAD terminal, or the G (General Purpose Output) relay or an external switchblock attached to the bus. The sense of its operation can also be reversed, i.e. it can turn on the terminal when the function decides the load should be disconnected. This can then be used as a low battery alarm or to drive a relay to turn off other loads.

The connection to real switches is set up in the MODE menu. See section 7.5 for details.

DO NOT CONNECT AN INVERTER OR ANOTHER BATTERY TO THE LOAD TERMINAL. This terminal is rated at 40A. Most inverters draw larger currents than this and have their own low battery cut off circuitry anyway. In general, Inverters should be connected directly to the battery.

4.0 IN Menu

IN

The IN screen gives a running total of Amp hours (Ah), or energy, that has been put into the battery during the day (since midnight). This total is the sum of Solar Ah collected directly through the Dingo and any measured external Ah input.

IN/INT

From the IN screen, a long push displays INT (Internal Ah IN). This is the running total of Ah collected through the SOL terminal over the day (since midnight). A long push will clear the INT running total.

IN/External

From the INT screen, a short push displays any external Ah contributions. This is the running total of each external Ah input from MPPT, Switchblock or current shunt measurements. A long push will clear a total.

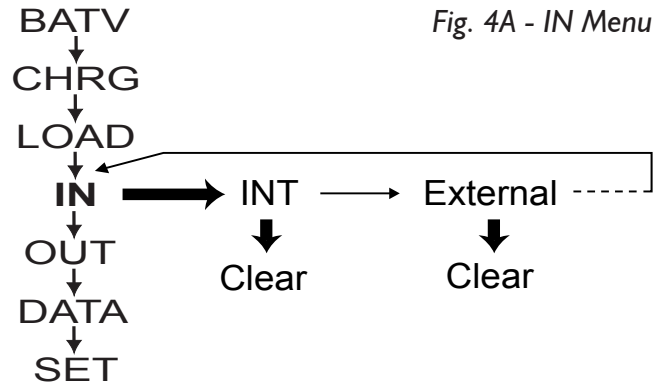

Fig. 4A - IN Menu

5.0 OUT Menu

OUT

The OUT screen gives a running total of Amp hours (Ah), or energy, that has been used during the day (since midnight). This total is the sum of Ah used by equipment connected to the LOAD terminal and any external devices.

OUT/INT

From the OUT screen, a long push displays INT (Internal Ah OUT). This is the running total of Ah used by equipment connected to the regulator’s LOAD terminal. A long push will clear this total.

OUT/External

From the INT screen, a short push displays any external load Ah. Long push to clear.

Note: the net battery Ah is the IN Ah -OUT Ah.

The IN and OUT Ah counters are reset each day at midnight.

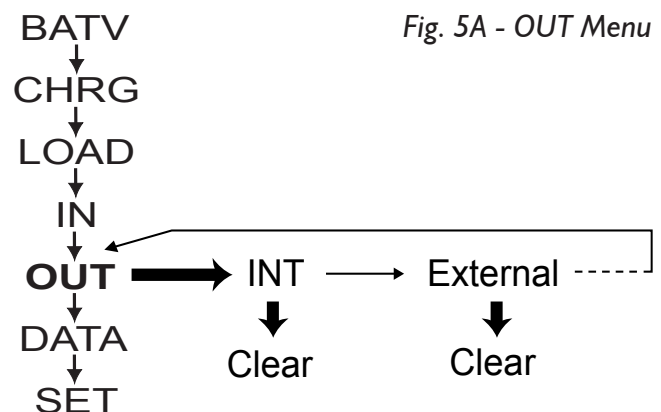

Fig. 5A - OUT Menu



6.0 DATA Menu (Retrieving Performance Data)

A long-push on DATA, enters the data menu. This displays performance information for the current day.

The screens in the DATA menu have the following meanings:

VMAX	maximum battery voltage since midnight.
VMIN	minimum battery voltage since midnight.
FTIM	time of day the regulator entered the Float state.
SOC	estimated state of charge of the battery based on the amp hours in and the amp hours out. A very rough 'fuel gauge' -see below for further details.
TEMP	temperature being sensed by the external temperature sensor (if attached).
SOLV	solar panel voltage (open circuit)
HIST	entry point for history data.

At midnight, VMAX, VMIN, FTIM, SOC, IN and OUT are stored in the history data and cleared from the current day readings.

6.1 & 6.2 VMAX and VMIN

VMAX and VMIN respond very slowly to changes in battery voltage. This allows them to ignore short term voltage fluctuations. A long push will reset the value to the current battery voltage.

6.3 FTIM (Float time Display)

FTIM indicates the time of day that the regulator

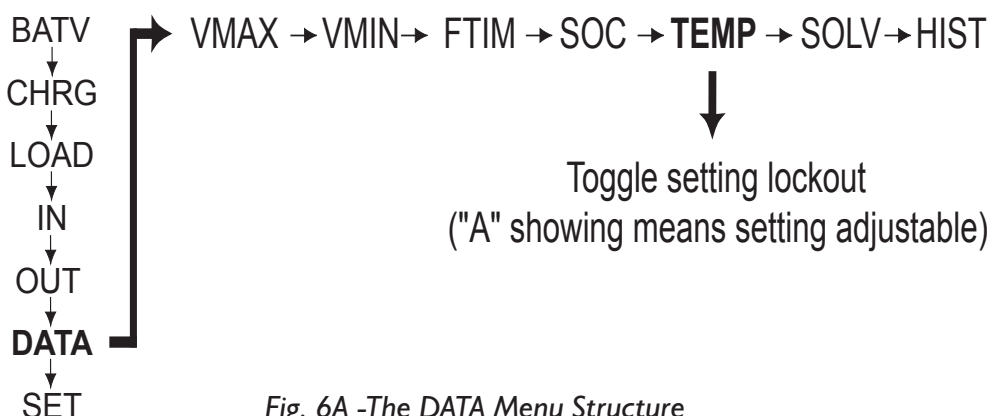

Fig. 6A -The DATA Menu Structure

changed from the ABSB (Absorption) state to the FLOT (Float) state.

This time will only be recorded if the regulator has done a transition into float that day. A time will not be recorded if the controller did not reach the float state or stayed in float all day. No float time displays as a '-'.

6.4 SOC (State of Charge Display)

SOC (State Of Charge) should be read as a percentage estimate of how full the battery is.

This estimate is based on the amp hour balance counter. The counter keeps a running balance of amp hours in vs amp hours out. The SOC display shows this balance as a percentage of the battery size. Note that all system currents must be monitored by the regulator and the battery capacity must be entered by the installer at the BCAP setting before SOC will be accurate.

$$\text{SOC (\%)} = \frac{\text{Ah balance counter}}{\text{BCAP}} \times 100$$

Over time, a pure amp hour balance counter will drift out of line with the real battery state of charge. To keep the counter better aligned with reality, the Dingo automatically makes a number of corrections:

1. When the controller state changes from boost to absorption, SOC is set to 90% if it is <90%. When the controller state changes from absorption to float, SOC is set to 100%.
2. Charge current is corrected for loss due to gassing, based on the battery voltage.
3. A correction for self discharge is made daily (at midnight) This is temperature corrected.
4. A slow correction is applied where the SOC inferred

from the battery open circuit voltage can be determined. A temperature sensor must be attached for this correction to work accurately.

If you use a temperature sensor, you will get a more accurate SOC estimate.

A long push on the SOC screen will allow the SOC to be adjusted to the users best estimate of the present SOC.

The SOC figure should be treated with caution, as there are many reasons that it may be inaccurate:

- The Dingo does not automatically have knowledge of the whole system. It only knows what you tell it. For SOC to work well, it must be measuring all charge (Ah in) and discharge (Ah out). If the battery can charge or discharge without the Dingo knowing, SOC will not be very accurate.
- The effective capacity of the battery reduces with age. BCAP should be reduced in older batteries to adjust for this.
- When you set up BCAP on installation, you should choose your best guess of the batteries actual capacity when used in the way you intend to use it. For example, if you think the battery will mostly be charged and discharged at around the 20h rate (C/20) you should set the capacity of you battery at the 20h rate from the manufacturer's literature. If you expect the battery to be used at a variety of charge and discharge currents, try to estimate an average.
- Peukerts equation can be used to estimate the loss in capacity at higher discharge rates. Correction based on Peukerts equation is not done automatically because it does not model discontinuous and variable rate discharge very well and changes with battery age.

6.5 TEMP (Display External Battery Temperature and Setting Lockout)

This screen displays the external battery temperature sensor reading (if attached) or “-” if it's not. It is also used to adjust Setting Lockout (see figure 6.A).

Setting Lockout

In some cases it is desirable to restrict the ability to adjust settings, so as to prevent unwanted tampering.

To disable settings, long push on the TEMP screen. The “A” indicator will disappear. A useful memory aid is to consider that “A” stands for “Adjustable” on this screen.

To enable adjustment of settings again, long push on the TEMP screen again. If you have successfully enabled settings adjustment, the “A” will reappear while TEMP is showing.

The controller remembers the state of the settings lockout when the power is disconnected.

6.6 SOLV (Solar Voltage Display)

This screen displays the open circuit solar panel voltage

The charge current through the SOL terminal is turned off while the Dingo is displaying this screen. If the view is left on the SOLV screen, the charge current will be automatically reconnected after 18-24 minutes. This is to prevent battery failure due to lack of charge (failsafe).

6.7 HIST (History display)

Six pieces of data are recorded each day. These are:

Total Ah IN for the 24hrs. This is a measure of the energy collected that day

Total Ah OUT for the 24hrs. This is a measure of the energy used that day.

VMAX - the maximum battery voltage that day.

VMIN -the minimum battery voltage that day,

FTIM - time of day the controller changed to float mode. ('-' if it didn't)

SOC. -the state of charge at the end of the day

These figures are a very good guide to how well the solar system is performing. The user can compare the energy collected with the energy used and get some feedback about the balance between collection and use.

These records are available for the past 99 days on the screen of the controller. The controller actually keeps records for over one year, but for practical reasons, these can only be accessed via the computer interface. The records are not lost if the power is disconnected.

At the start of each day record is the DAY screen. This shows which day's data you are looking at (DAY 1 = yesterday, DAY 2 = the day before yesterday, etc.)

For help with navigating through the History, refer to Fig.6B.

A long push on each of the screens except EXIT will move down to the next day or the next day's value. Short pushes move between figures for the same day.

NEXT goes to the next day, BACK goes to the previous day. The day numbers wrap around when they reach the end.

A short push on the EXIT screen will take you back to the beginning of that day's record. A long push will exit back to the DATA screen.

Fig. 6B - The History Menu

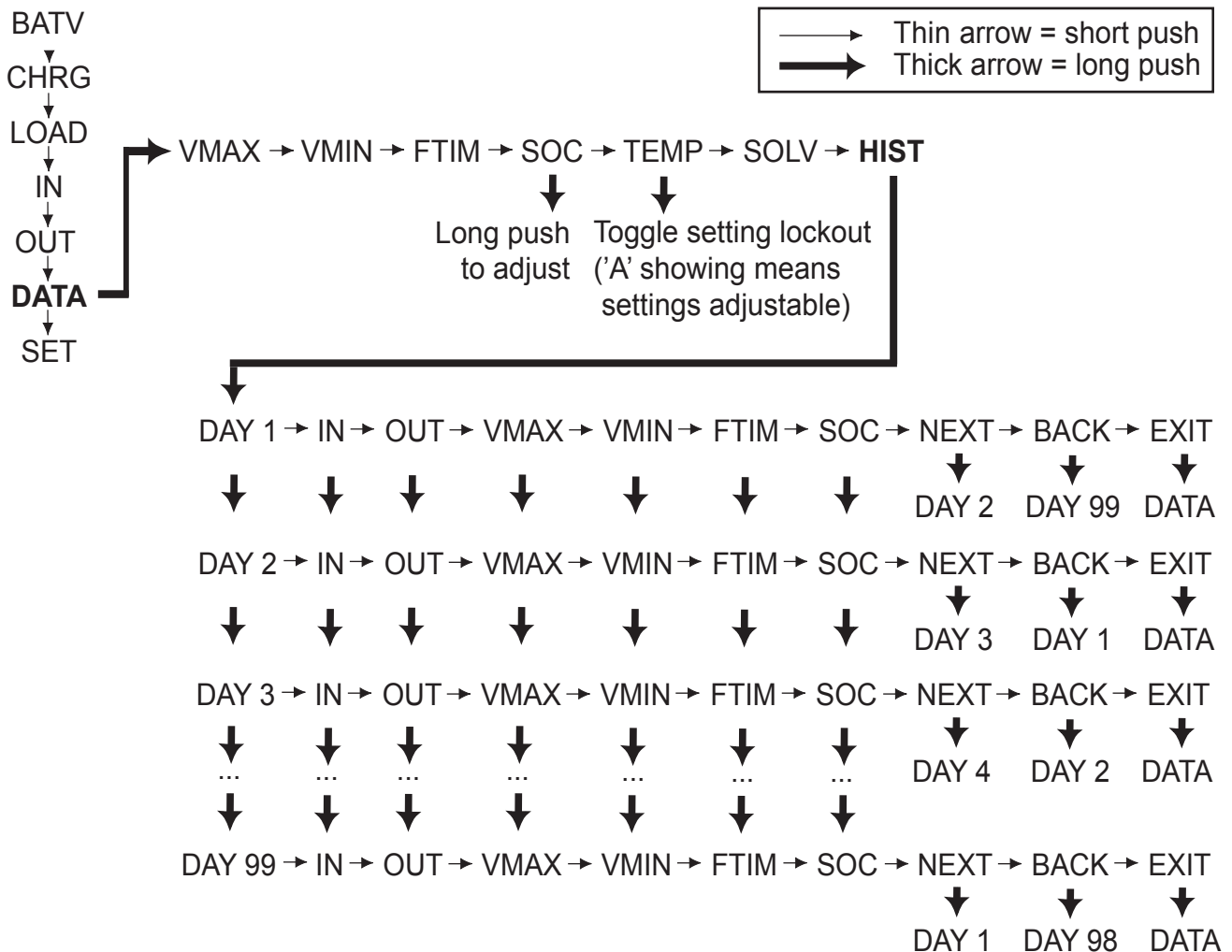

7.0 SET menu

The set menu contains most of the settings which control the operation of the controller.

7.1 TIME

This screen displays the time on the controller’s clock. A 24hr format is used for system time, with a resolution of 6 minutes (0.1 hours) So, for example, 14.3 is 2:18 PM.

NOTE: Removing power to the regulator (i.e. turning it off) will reset the system time to 10.0hrs (10:00 AM).

The time must be set whenever the regulator is restarted. Incorrect system time will result in misleading history data since this is stored at midnight of each day. Generator quiet-time and time-driven event control will also be affected.

7.2 VOLT

Set VOLT to the nominal system voltage for the installation.

This setting determines the regulation and control voltage set-points for the system. For correct regulation, this setting **MUST** be correct.

NOTE: The controller will not be damaged if the voltage is set incorrectly but the battery will probably be damaged (under- or overcharge) if this setting is in error for more than a few days.

7.3 PROG (Adjusting Regulation Settings)

The Dingo comes with a number of preconfigured programs, which are set up for generic batteries. For custom installations, selecting program 4 allows the user to adjust each setting individually.

If you find you are unable to change your settings, it may be because the “lockout” setting is activated. This setting is designed to prevent unwanted tampering— please see the “Setting Lockout” information in section 6.5.

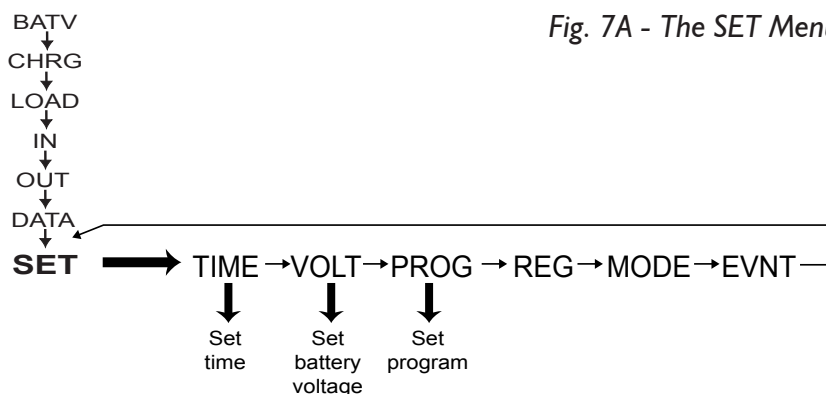

Fig. 7A - The SET Menu

Program Function Table (Generic Programs)

Program#:	0	1	2	3
Batt Type:	Flooded	Sealed	Flooded	Sealed
LOAD Term Functions:	No Night Light		Night Light	
	Low Battery Disconnect			

Low Battery Disconnect is enabled for Programs 0-3. Programs 2&3 turn on the LOAD terminal at night for lighting applications.

Program Description

PROG 0: Use with liquid electrolyte lead acid (ie. flooded) batteries. The LOAD terminal is set to turn off when the battery is low. (Also known as Low Battery Disconnect)

PROG 1: Use with sealed or gel lead acid batteries. The LOAD terminal is set to turn off when the battery is low.

PROG 2: Use with liquid electrolyte lead acid batteries (ie. flooded). The LOAD terminal is set to turn on all night and can be used for night lighting. It will turn off when the battery is low (Low Battery Disconnect).

PROG 3: Use with sealed gel lead acid batteries. The LOAD terminal is set for night lighting, with low battery disconnect.

PROG 4: Enables customised adjustment of all settings.

Installation instructions for programs 0-3 are on pages 8-9 of the User Guide.



Settings Used in Programs 0-3

When programs 0-3 are selected, the Dingo automatically uses the values below in its regulation. These are not visible on the screen and are not adjustable by the user. For adjustable settings, choose program 4.

The voltage settings are shown correct for 12V operation. For higher voltages, scale these up (eg. for a 24V system, multiply each voltage figure by 2.)

CHRG		Setting for program number			
Parameter	0	1	2	3	
GMOD	0				
G ON (V)	11.5				
G OFF (V)	13.8				
GDEL (Min)	10				
GEXD (Day)	30				
GRUN (Hr)	1.0				
LOAD					
Parameter	0	1	2	3	
LOFF (V)	11.3				
L ON (V)	12.8				
LDEL (Min)	10				
SET/REG					
Parameter	0	1	2	3	
BMAX (V)	15.0	14.2	15.0	14.2	
EMAX (V)	16.0	14.0	16.0	14.0	
ETIM (Hr)	1.0	0	1.0	0	
EFRQ (day)	45				
ABSV (V)	14.0				
ATIM (Hr)	2.0				
FLTV (V)	13.8				
HYST (V)	0.4				
BRTN (V)	12.3				
CLIM (A)	40				
BFRQ (Day)	15				
TCMP	0				

SET/MODE	Setting for program number			
Parameter	0	1	2	3
LSET	1	1	4	4
GSET	2	2	9	9
ESET	see below			
BSET	0	0	2	2
BAT2 (V)	14.0			
PWM	1			
ALRM (V)	11.4			

SET/MODE/ ESET	Default Settings (see section 7.5.2)
SW I to C	0 (charge switch -on to charge)

SET/EVNT	Setting for program number			
Parameter	0	1	2	3
STRT	0			
TIME (Hr)	0			
STOP	0			
TIME (Hr)	250			
EMOD	2			
TMOD	0			

Settings for Program 4

If program 4 is selected, then all settings can be accessed and adjusted.

After TIME, VOLT and PROG, there are entry points for three further sub menus:

REG Allows the user to customise the regulation settings (see below for details).

MODE Allows the user to adjust other configuration options.

EVNT Settings for the event controller.

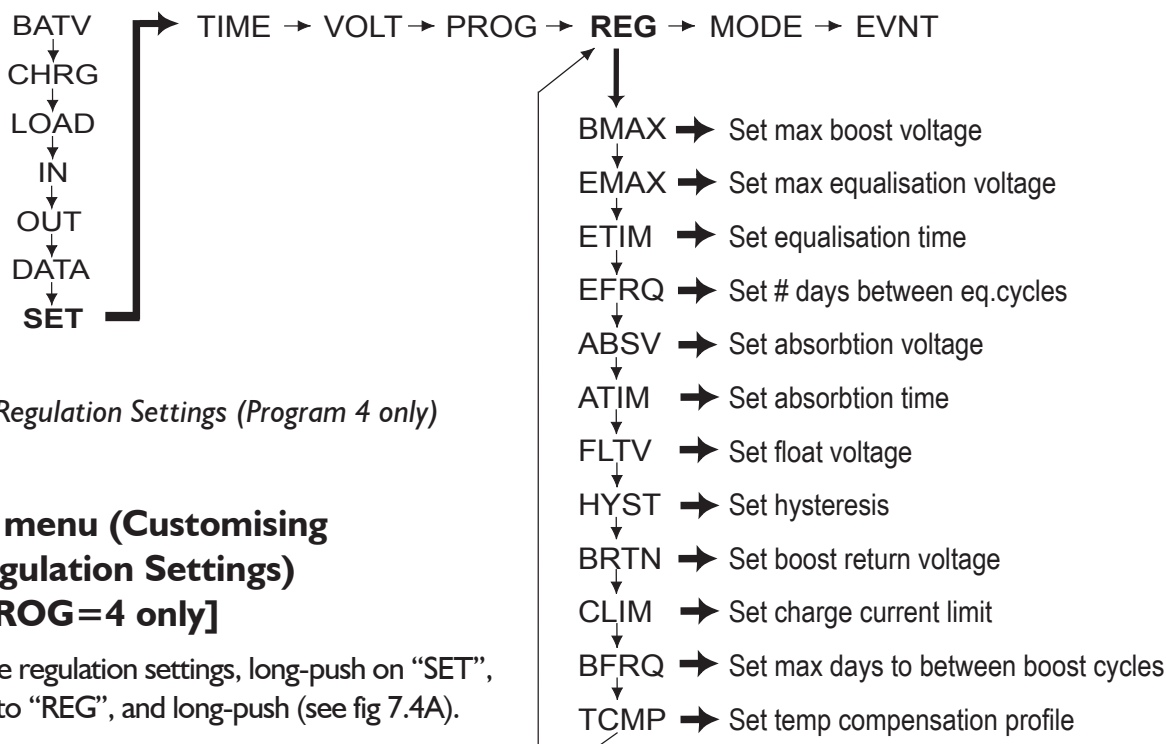

Fig. 7.4A - Regulation Settings (Program 4 only)

7.4 REG menu (Customising Regulation Settings) [PROG=4 only]

To adjust the regulation settings, long-push on “SET”, short-push to “REG”, and long-push (see fig 7.4A).

The settings given below are for 12V systems. For other system voltages the value can be scaled from this. (eg. for a 24V system, multiply all voltages by 2.)

SET/REG Submenu Summary:

Name	Description	Range
BMAX	Maximum voltage in boost mode	13.5-16.5V
EMAX	Equalisation voltage	14.0-17.0V
ETIM	Equalisation time	0-2.0 hours
EFRQ	Number of days between equalisation cycles	20-150
ABSV	Absorption voltage	13.5-15.5V
ATIM	Absorption time	0-4.0 hours
FLTV	Float voltage	13.0-15.0V
HYST	Hysteresis used when not in PWM mode	0.1-1.0V
BRTN	Voltage below which return to Boost mode occurs	11.0-13.0V
CLIM	Charge current limit	1-40A
BFRQ	Maximum number of days between boost cycles	1-20
TCMP	Selection of temperature compensation profile (see below 7.4.3)	0-8

7.4.1 HYST (Hysteresis Value)

When not in PWM mode, the Dingo controls the battery voltage by simply switching the charge current on and off. It turns off the charge current at the relevant voltage set point for the state (Float, Boost, Equalise, Absorption), and allows the charge current to turn back on at a slightly lower voltage. The gap between the two voltages is called hysteresis.

Example:

With the Dingo in float mode and slow switching (i.e. not using PWM), the charge current will be turned on until the battery voltage rises to the FLTV value. Once the FLTV value has been reached, the charge current will be turned off until the battery voltage falls to FLTV – HYST (float voltage minus the hysteresis value) at which time the charge current will be turned on again until the battery reaches FLTV and the cycle begins again.

The larger the hysteresis values, the slower the rate of switching on and off will be.

NOTE: When switching a mechanical relay for regulation purposes, the HYST value may need to be increased so that the relay does not wear out quickly due to rapid switching.



Timers:

The HYST value is also used to start and stop the timers associated with the different regulator charging states (Boost, Equalise, and Absorption).

Example:

When the Dingo changes to the Absorption state, an internal timer is started to monitor how long the regulator has been in Absorption. If however the battery voltage falls lower than ABSV - HYST this timer is stopped, and starts again when the battery voltage rises above ABSV - HYST. This ensures that the regulator holds the system in the required state for the correct programmed time and doesn't continue to the next charging stage until this time has elapsed.

NOTE: An exception to this is the Equalise State, which will terminate after 4 days if unable to complete the full specified time period.

7.4.2 CLIM Charge Current Limit

The Dingo has a built-in charge current limit. If the charge current exceeds the CLIM setting, the charge duty cycle will be reduced to limit the average charge current.

This allows the Dingo to protect itself from overheating due to excessive charge current. The maximum charge current can also be limited for small batteries where the full array current might be too much for the battery. This is useful for systems, which are marginal in winter, but have too much charge current for the battery in summer.

It can also be useful where there is an initial ageing effect in the first few months of the life of the module. For example, with amorphous modules the initial current may be more than the charge current rating of the Dingo. Making use of this feature, panels can be installed with the full rating calculated after the initial drop off.

NB. Current limiting is only done for the Dingo. It is not done for the external charge switches.

7.4.3 TCMP (Temperature compensation)

(Default=0, Adjustable in Program 4 only)

A temperature sensor is available which allows the

SET/REG/TCMP Selection Summary:

TCMP	Function	Example Battery
0	-5mV°C linear auto sense (default)	General Purpose - use this if in doubt
1	gentle curve auto sense	BP Solar Block
2	steeper curve auto sense	Sonnenshein Dry Fit
3	limited range curve auto sense	Absolyte battery
4	-5mV°C linear non auto sense	General Purpose - use this if in doubt
5	gentle curve non auto sense	BP Solar Block
6	steeper curve non auto sense	Sonnenshein Dry Fit
7	limited range curve non auto sense	Absolyte battery
8	No temperature sensor	(Failsafe if short across T- T+ inputs)

Note: Without a temperature sensor fitted, the Dingo TEMP display will be blank if autosense is enabled and shows -21°C if non autosense.

Dingo to adjust its regulation voltage settings to compensate for variations in battery temperature.

The setting TCMP is used to select a temperature profile, which determines how this compensation is achieved.

The Dingo can automatically sense the presence of a temperature sensor if one of the auto-sense profiles is selected. However, if operation at temperatures below -12°C is common, it is better to use the non auto sense profile (TCMP=4-7). The auto sense will not detect sensors colder than -16°C

Fig. 7.4.3B shows the temperature compensation curves for each TCMP setting. Consult the battery manufacturer for correct compensation for the battery used.

Connecting a Temperature Sensor

The temperature sensor should be connected to the T+ and T- terminals on the green terminal block (see p37). The sensor wire with the stripe goes to the T- terminal and the sensor wire without the stripe goes to T+ terminal. The wires may be extended if necessary without affecting the accuracy.

Note: The DTB (bolt-on metal lug) has no electrical connection to metal lug housing, so it can be connected to either the negative or positive battery terminal.

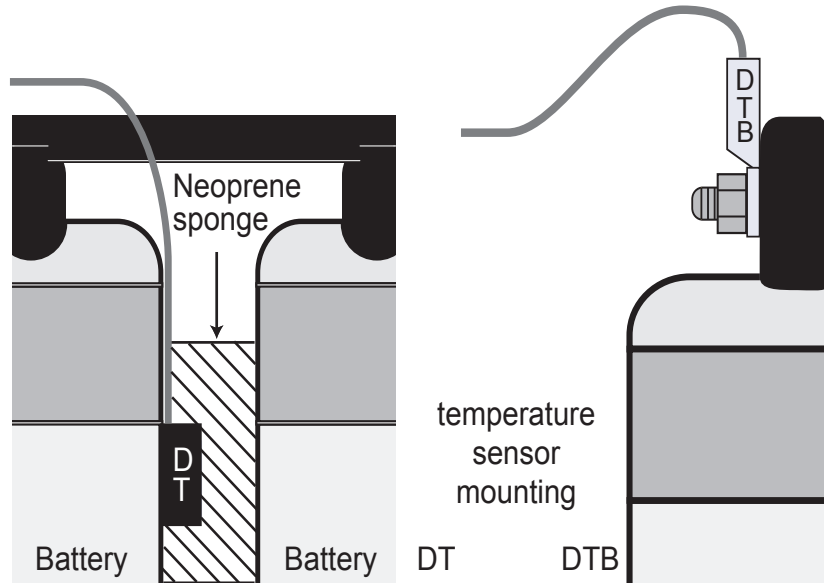

Fig. 7.4.3A - Attaching a Temperature Sensor to a battery

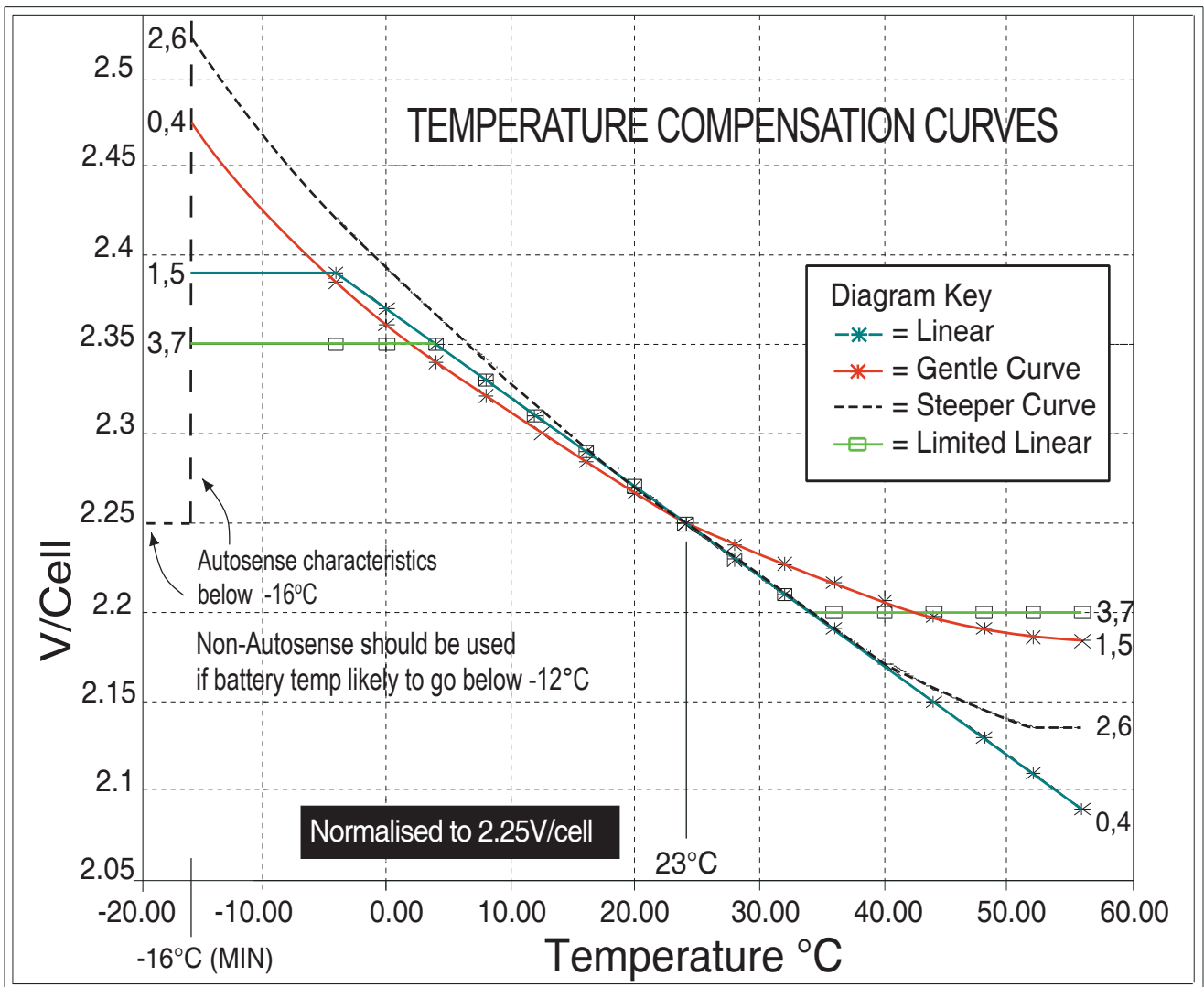
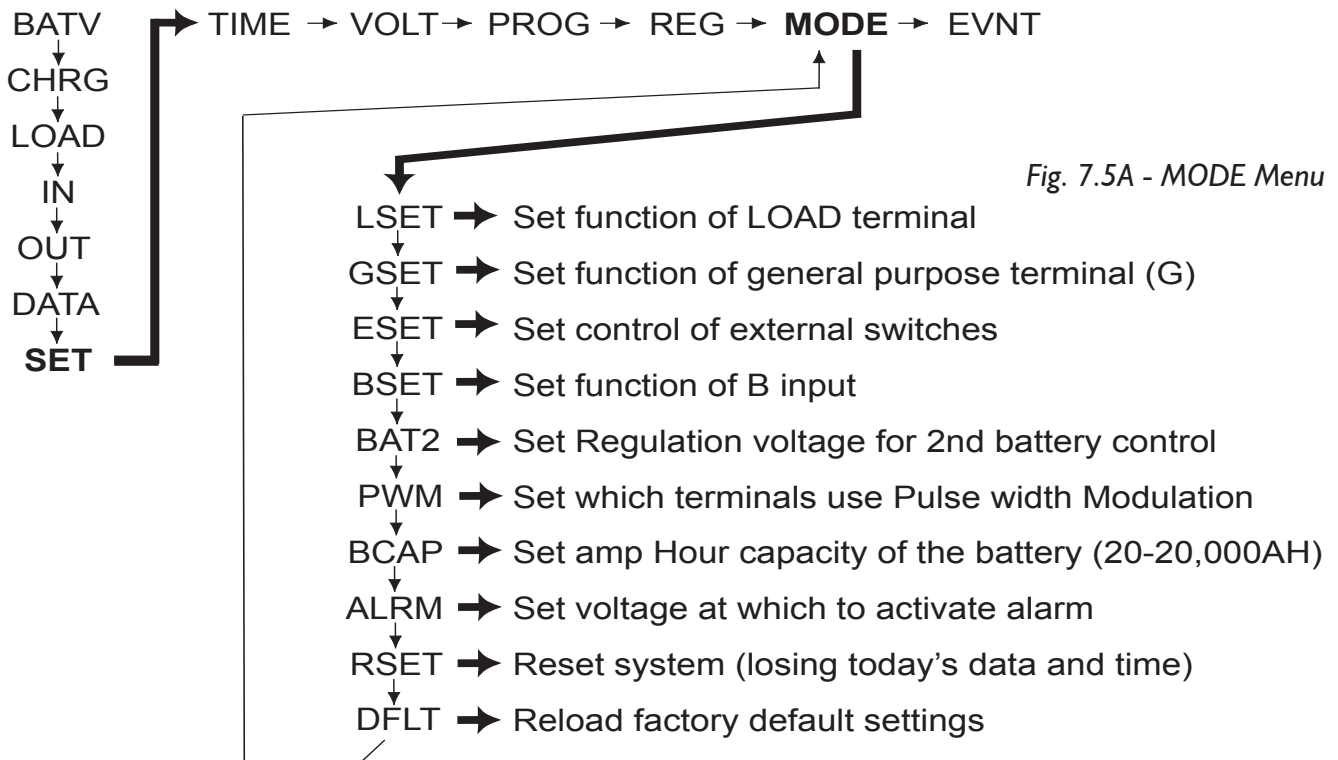

Fig. 7.4.3B - Temperature compensation curves





7.5 MODE Menu (Adjusting Configuration Settings) [PROG=4 only]

The MODE submenu contains most of the settings for the configuration of the Dingo other than the main regulation settings.

- f. Event controller. An output which is active when a specified set of conditions occurs.

7.5.1 LSET & GSET

There are two output terminals on the Dingo (LOAD and “G”) and six logical control functions. The LSET and GSET settings define which of the six functions controls each of these output terminals.

Note that the settings described below are different from the LSET and GSET screens described in Section 2 and 3.

The six internal control functions are:

- a. Low battery disconnect. This also controls the “LOAD” indicator at the bottom of the screen.
- b. Run the backup generator. This also controls the “GEN” indicator at the bottom of the screen.
- c. Charge a second battery. Indicates when the solar input can be diverted to a 2nd battery.
- d. Battery voltage alarm output. Provides an output based on the battery voltage.
- e. Shunt regulation. Gives an output useful for

SET/MODE Selection Summary:

Name	Description	Range
LSET	Select the control of the LOAD switch	0-11
GSET	Select the control of the “G” relay	0-11
ESET	Select the control for external switchblocks	see 7.5.2
BSET	Select the use of the B- sense input	0-3
BAT2	Regulation voltage for 2nd battery control	13.0-16.0V
PWM	Select which terminals use PWM (SOL, LOAD)	0-3
BCAP	Amp hour capacity of the battery bank	20-20,000Ah
ALRM	Alarm voltage	10.0-18.0V
RSET	Resets the controller (warm reboot). Clears day data and time	
DFLT	Resets Prog 4 settings to Prog 1 settings. Used to reset factory default settings.	

SET/MODE/LSET

#	Function	Terminal is:
0	Low battery disconnect	on when function wants to disconnect battery
1	Low battery disconnect (default)	off when function wants to disconnect battery
2	Generator control	on when function wants to run generator
3	Generator control	off when function wants to run generator
4	Event control	on when event is on
5	Event control	off when event is on
6	2nd battery charge control	on when battery 2 should charge
7	2nd battery charge control	off when battery 2 should charge
8	Alarm output	on when battery voltage < alarm setting
9	Alarm output	off when battery voltage < alarm setting
10	Shunt control (Must be selected for PWM control of the LOAD-terminal)*	off when function wants to disconnect the shunt load (ON for regulation)
11	Shunt control (PWM must not be set to 2 or 3)*	on when function wants to disconnect shunt load (OFF for regulation)

* Don't use LSET=11 with PWM, as design does not allow inversion of PWM signal.

The LSET setting allows the user to choose which function controls the electronic switch connected to the LOAD terminal. The user can also select whether that switch is on or off when the function is active. (i.e. select normally open or normally closed)

For example, if LSET is set to 8, then the load switch would turn **ON** if the battery voltage is lower than the alarm voltage setting (ALRM). This could be used to turn on an alarm light.

SET/MODE/GSET

#	Function	Terminal is:
0	Low battery disconnect	on when function wants to disconnect battery
1	Low battery disconnect	off when function wants to disconnect battery
2	Generator control (default)	on when function wants to run generator
3	Generator control	off when function wants to run generator
4	Event control	on when event is on
5	Event control	off when event is on
6	2nd battery charge control	on when battery 2 should charge
7	2nd battery charge control	off when battery 2 should charge
8	Alarm output	on when battery voltage < alarm setting
9	Alarm output	off when battery voltage < alarm setting
10	Shunt control**	off when function wants to disconnect shunt load (ON for regulation)
11	Shunt control**	on when function wants to disconnect shunt load (OFF for regulation)

** Note: PWM is not available on G Terminal

If LSET is set to 9, then the load switch would turn **OFF** when the battery voltage goes below the ALRM setting. This could be used to turn off a load to reduce the drain on the battery.

The GSET setting allows the user to choose which function controls the general purpose "G" relay, and whether it is on (closed) or off (open) when the function is active.

Shunt Control

The Dingo supports either series control, shunt control, or both at the same time. In a hybrid system, the main solar component is controlled by the SOL input and the other charge component (wind, hydro, etc) is directly connected to the battery and controlled by a dump load which diverts excess charge. The dump load is managed by the shunt control function. This can operate via the LOAD or 'G' terminal either directly or through a relay. These functions are configured in the LSET and GSET screens. (see above)

Regulating Wind / Hydro:

Shunt control is appropriate for wind generators or microhydro systems, which require a constant load on the charging source so the generator doesn't overspeed and destroy itself. In this case the charging source must remain connected to the battery at all times.

"Shunt control" (also referred to as "diversion control") refers to the technique of controlling the battery voltage by drawing energy from the system with a 'dump load', rather than disconnecting the charge source as "series control" does on the solar input.

To regulate a wind or microhydro installation with shunt control, a dedicated dump load must be available for the Dingo to switch across the battery. The dump load current should be larger (at the range of expected battery voltages) than the maximum charge current available from your generator.

The function of the dump load is to 'soak up' energy coming in which the battery cannot store in order to maintain the desired battery voltage.

7.5.2 ESET: External switch setup

The Dingo has a serial bus which allows the user to add external devices to increase the control system's capability. One such device is an electronic switch. This can be used to increase the charge current being regulated or increase the load current being controlled by the load disconnect function.

The user needs to select which internal function

will control each external switch block. This is done in the ESET sub menu. A long push on ESET brings up the first switch setting. Short pushes move to the next switch until ESET returns after switch C.

The following table shows the control options.

SET/MODE/ESET Selection Summary:

Selection	Function
0	Charge control (normal/slow) On when Dingo wants to charge
1	Charge control (shunt/slow) Off when Dingo wants to charge
2	Load disconnect (inverse) On when load should be off
3	Load disconnect (normal) Off when load should be off
4	Alarm (normal) On when battery < ALRM voltage
5	Alarm (inverse) Off when battery < ALRM voltage
6	Event (normal) On when the event is active
7	Event (inverse) Off when the event is active

7.5.3 BSET: Configuring the B- Sense Input

The terminal labelled B- (right most terminal of the green terminal block) is intended as a sense input for the battery negative voltage. This can be connected directly to the negative terminal of the battery so that the true battery voltage can be read. This is important if there is significant voltage drop along the wiring (including any fuse) between the BAT- terminal on the Dingo and the real battery negative. (If there is significant voltage drop on the positive side, then take the BAT+ terminal directly to the battery positive via a fuse. The fuse need only be rated for the Dingo supply current, say 100mA. Take the positive side of the charge current from the array to the battery separately via it's own fuse. The intention is that the array current does not pass through the same wire as the Dingo negative supply current). See figure 7.5.3A

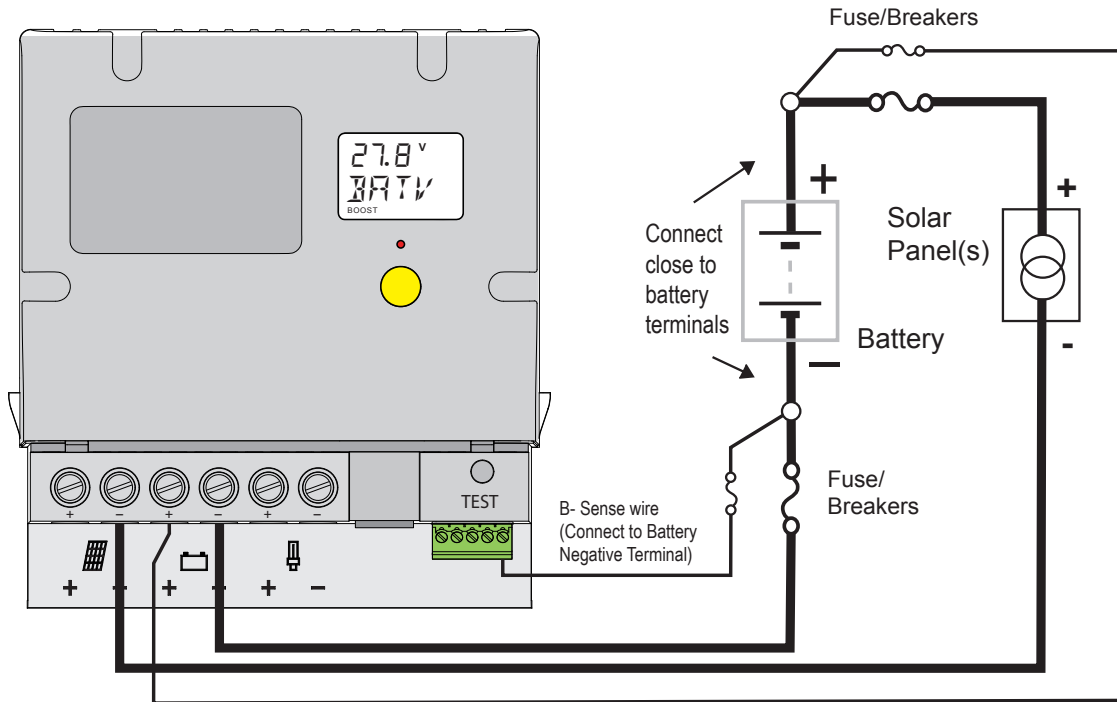

Fig. 7.5.3A - Battery Sense Input

If the B- input is not being used for this, then it can be used for sensing the voltage on a second battery being charged or for providing a voltage input for the event controller (VEXT).

Some inverter-chargers, such as the SP PRO, can communicate to the charge controller when they want to export power to the grid. Selecting BSET=3 enables this.

‘Push Button’ Switch Input

To use the B- sense input as a switch event input, wire a switch (or other voltage free contact closure device) between the B- terminal (green terminal block) and the Bat- terminal (and set BSET = 2). See Figure 7.5.3B

This is an example of using a push button switch to turn on a light - see section 7.6 Event controller example 2 for setting details.

Fig. 7.5.3B - Push button connection

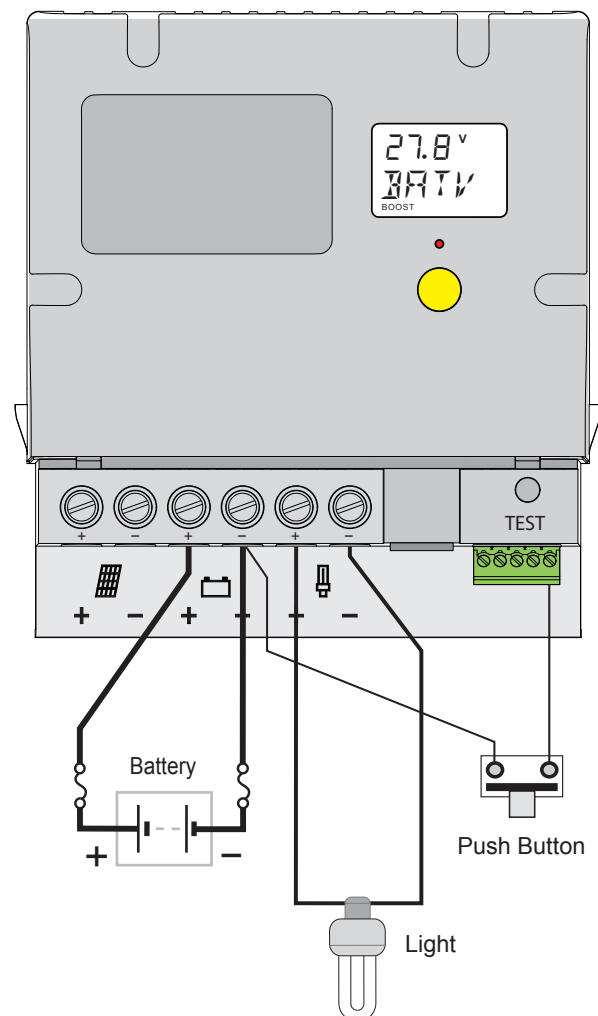

SET/MODE/BSET Selection Summary:

Selection	Function
0	B- input used for battery negative voltage sensing
1	2nd battery voltage sensing
2	Used as the VEXT voltage by the event controller
3	force equalise when connected to BAT-

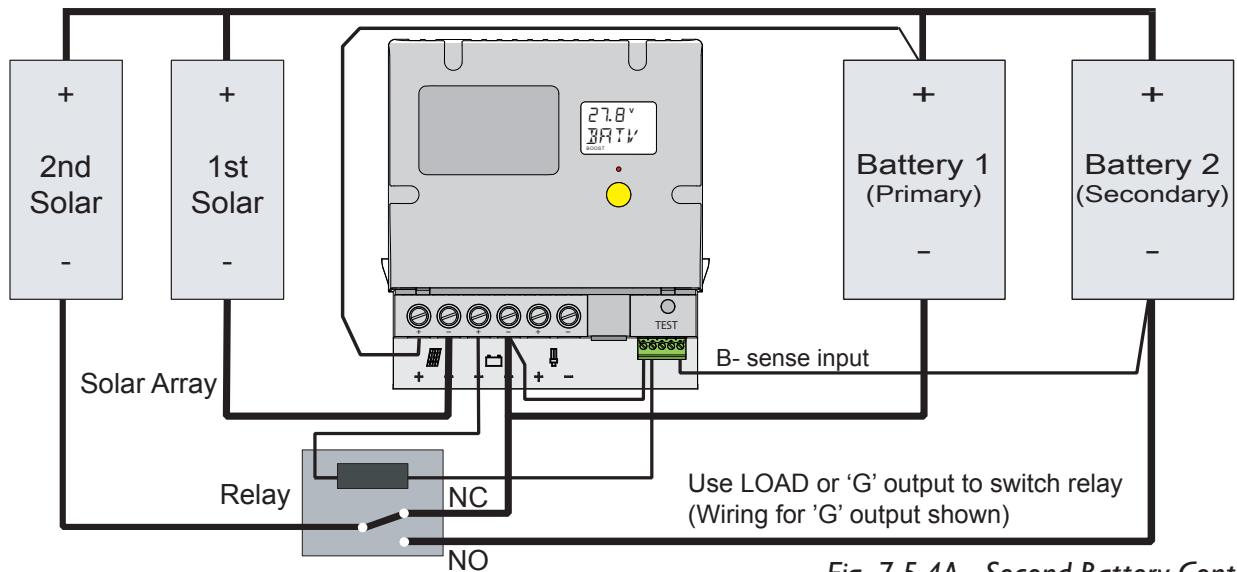

(Relay shown in non-energised state)

Fig. 7.5.4A - Second Battery Control

7.5.4 BAT2 - Second battery control

On many afternoons, there is power available from the solar panels but it is wasted because the batteries are already full by then. This power could be used to charge a second or reserve battery bank. The Dingo has a separate single stage controller for a 2nd battery built into it. This allows the second battery to charge if the main battery has reached the float state and the voltage on the 2nd battery is below the setting in the BAT2 screen.

The second battery control function uses a relay to switch the solar array negative from the primary battery to the secondary battery.

NOTE: Second battery control is not suitable for use in negative ground systems since it uses the B- sense input and requires the battery negative terminals to be separated (i.e not both connected to the chassis) Use a negative ground controller (Like the Dingo 2020) in this case.

With the positives of the two batteries joined together, the Dingo can read the voltage on the second battery from the B- sense input. An external switching device such as a changeover relay will be required to switch the negative of the solar panel(s) from the SOL- terminal of the Dingo to the negative terminal on the second battery (see fig 7.5.4A).

Use either the Load terminal or 'G' relay for switching the changeover relay (the 'G' relay max current is only 300mA, but this should be enough

to drive most relays). The following settings will also need to be configured:

PROG=4	allows changing LSET, GSET, BSET etc
LSET=6 or GSET=6	LSET if using load terminal for relay, GSET if using the 'G' relay to switch the changeover relay
BSET=1	'B-' input used for 2nd battery control

The 'B-' sense input is wired to the negative terminal of the second battery and allows voltage monitoring of the second battery voltage. This allows the regulator to perform basic single stage regulation of the second battery by switching the relay on or off to connect/disconnect the charge source. A second regulator is NOT required.

The changeover relay will need to meet the following minimum specifications:

- Correct coil voltage to match the system voltage, ie. able to handle the maximum battery voltage.
- Output contacts rated for DC current.
- Output contacts rated to handle the maximum current that the connected panels can output.

Note: It is suggested that customers leave some panels permanently connected to the regulator SOL- input (1st solar) and switch all the other panels (2nd solar) across with the relay. This leaves a regulated 'maintenance' charge available for the

primary battery, and can minimise the amount of switching required by the relay (which switches over each time the primary battery bank voltage falls below *FLTV - HYST*). The maximum relay switching rate is one cycle per 30 seconds. A pair of DC output solid state relays is a good choice here.

This setup may not be the best use of available charge current. Consider if it would be better to increase the size of the primary battery bank.

7.5.5 PWM and Slow Switching

When the Dingo is trying to keep the battery voltage constant, it does this by turning the charge current on or off as required. It can do this quickly or slowly.

PWM (fast switching):

SET/MODE/PWM: [PROG= 4 Only]

Selection	Function
0	No PWM used
1	PWM on SOL terminal only
2	PWM on LOAD terminal only
3	PWM on both

In the fast switching mode, the Dingo uses pulse width modulation (PWM) at 58Hz. It is recommended that PWM control be used unless there is good reason not to, as it provides a smoother control and faster charging.

PWM may generate some audio or radio frequency interference. If you experience noise on electronic equipment (for example AM radio), you could try selecting SET/MODE/PWM = 0 (slow switching only, option available when PROG=4). If this does not fix the problem, it's unlikely that the noise is generated by the Dingo.

The radio frequency interference from the Dingo has been tested in PWM mode and found to be very low. It is at least 15dB below the domestic limit for European CE, American FCC and Australian EMI compliance standards.

NOTE: More care must be taken at higher system voltages (particularly 48V) because the inductance of the wiring to the photovoltaic panels can

cause some 'ringing' on turn-off. Keep wiring as short as possible and panel cable pairs together (cable tie). On long wiring runs at higher voltages, some damping may be necessary and possibly some external clamping of transients. With highly inductive wiring, the transients may be large enough to damage the FET switch. Consult the factory if further information is required.

LOAD terminal PWM switching:

For PWM control to be available on the LOAD terminal, LSET must be set for Function 10 (Shunt Control).

DO NOT set LSET to Function 11 (Inverted Shunt Control) if using PWM on load terminal—see the LSET table.

PWM should only be enabled on the LOAD terminal (PWM = 2 or 3) if the LOAD terminal is being used to directly switch a dump load (no relay).

An exception to this is when the LOAD terminal is driving a solid state 'electronic' relay (non-mechanical), as these can usually switch at the PWM speed (58 Hz).

NOTE: PWM is not available on the G relay.

Slow Switching (non PWM):

In slow switching (non PWM) mode, the Dingo controls the battery voltage by slowly switching the charge current on and off. It turns the charge current OFF at the voltage set point for the relevant charge state, and turns the charge current back ON at a slightly lower voltage.

The gap between these two voltages is called hysteresis and is adjustable (HYST). The larger the hysteresis value, the slower the rate of switching on and off.

HINT: Increase the Hysteresis value if using shunt control with a mechanical relay so the relay switches less often.

In the slow switching mode, the regulator limits the *maximum* switching speed to 0.25 seconds between changes. This virtually eliminates any audio or radio frequency interference.



7.5.7 BCAP

BCAP setting tells the Dingo the effective Amp-hour capacity of the battery being charged. This is used by the State of Charge data screen. Long push on BCAP to set this value. Set the battery capacity actually expected as discussed in Section 6.4 (SOC).

BCAP's range is 20Ah-20,000Ah. Short pushes will increment BCAP by 20Ah until it reaches 1000 Ah. At this point, the increment increases to 100Ah and the display changes to thousands - i.e. 1000 is displayed as 1.0, and 1100 as 1.1. When the display reaches 20,000Ah (shown as 20.0), it will cycle back to 20Ah (shown as 20). It's important to notice the difference. If it is intended to set 20,000Ah, be careful not to set 20 Ah instead. The two appear one after the other on the Dingo display during setting. The only visible difference is the decimal point to show 20,000 Ah.

7.5.7 ALRM

Long-push here to set the alarm voltage. If the battery voltage falls below the alarm voltage, the Dingo will activate its internal Alarm function. This will cause the alarm led to light.(see A.5)

If the LSET / GSET settings have been configured appropriately, this can be used to enable an

Example - Battery Low Alarm Output

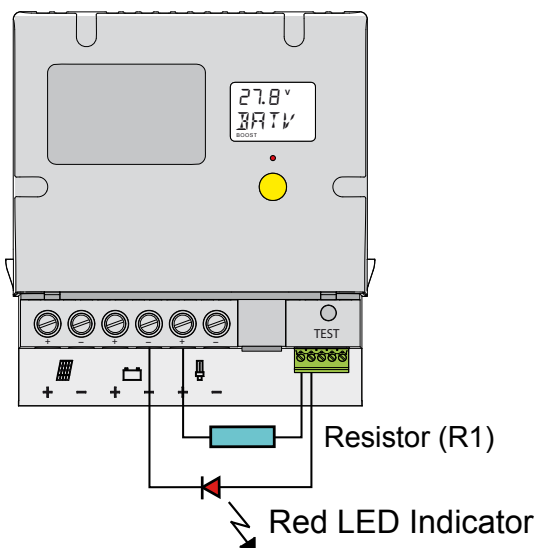

Fig. 7.5.7A - Alarm Wiring

alarm light (or other type of alarm) connected to the LOAD or 'G' terminal. There is no audible alarm built into the Dingo. It can send a signal or power to an external alarm of some kind. The reverse function could be used to turn off a low priority load when the battery voltage is getting low.

System	RI Value
12V	1K,1/4W,5%
24V	2K2,1/2W,5%
48V	4K7,1W,5%

(Higher wattage resistors may be used)

RI values are calculated to give adequate LED brightness at low battery voltage, but not burn-out at high battery voltages (eg. in case output function changed by mistake).

Settings:

SET / PROG=4
SET / MODE / GSET=8 (on when battery voltage < alarm setting)
SET / MODE / ALRM=11.4V
(for example. Set as required.)

7.5.8 RSET & DFLT

Reset (RSET)

A long-push on RSET will reset the Dingo's microcontroller (it's brain). This has the same effect as disconnecting the power to the controller except that it can be done without removing a wire. It is a 'warm reboot'.

Reset has the effect of clearing the day's Performance Data and setting the clock to 10:00 am.

Note that you will need to re-enter the current time on the internal clock, but your other settings and history will be retained.

Set Defaults (DFLT)

A long-push on DFLT will cause the settings for Program 4 to be reset to the settings for Program 1. This provides a way to return the program 4 settings to the factory settings.

7.6 EVNT Menu (Event Control)

The event controller allows something to happen when a set of conditions is met. There are many applications for this feature, such as:

- Turning on a light at night
- Using ‘waste’ energy pumping water in the afternoon if the Dingo is in the float state
- Sensor operated timed lighting at night
- Turning on sprinklers for an hour if it’s over a certain temperature

Using the Event Controller

Step 1 - Select PROG 4

In Programs 0-3 the event controller is set up to do a night light function. This function is available on the load terminal in programs 2 &3 and on an external switch. For users who wish to use the event controller in a different way, Program 4 must be selected.

Step 2 - Set LSET, GSET or ESET

It is necessary to tell the Dingo which output switch will be controlled by the Event Controller. For the LOAD terminal this is done using the

LSET setting. For the G relay use the GSET setting. Also, the event control can be assigned to one or more of the external switch blocks connected to the bus by using the ESET settings. These settings are described in Section 7.5.

Step 3 - Set the STRT condition.

The Dingo must be told what signifies the start of the event. Move to the EVNT menu, as shown in Figure 7.6A. A long-push on EVNT will move to the STRT setting. STRT uses the following table to determine what will start the event:

After setting the STRT value, a short-push will move you to the setting, which goes with that STRT value. For example, if you set STRT to “3”, you will see SOLV. Whenever the solar panel voltage drops below the value you set in SOLV, the “event” will start if the other conditions permit.

If the start condition is to be ignored, then select STRT=0 so that the start condition is always active.

Note: A start occurs when the start condition changes from inactive to active and the EMOD & TMOD conditions are active. Further starts are blocked while the start condition remains active. When the start condition goes inactive it clears the block. This prevents an event being immediately retriggered when it finishes.

Fig. 7.6A - Event Control Menu [PROG = 4 only]

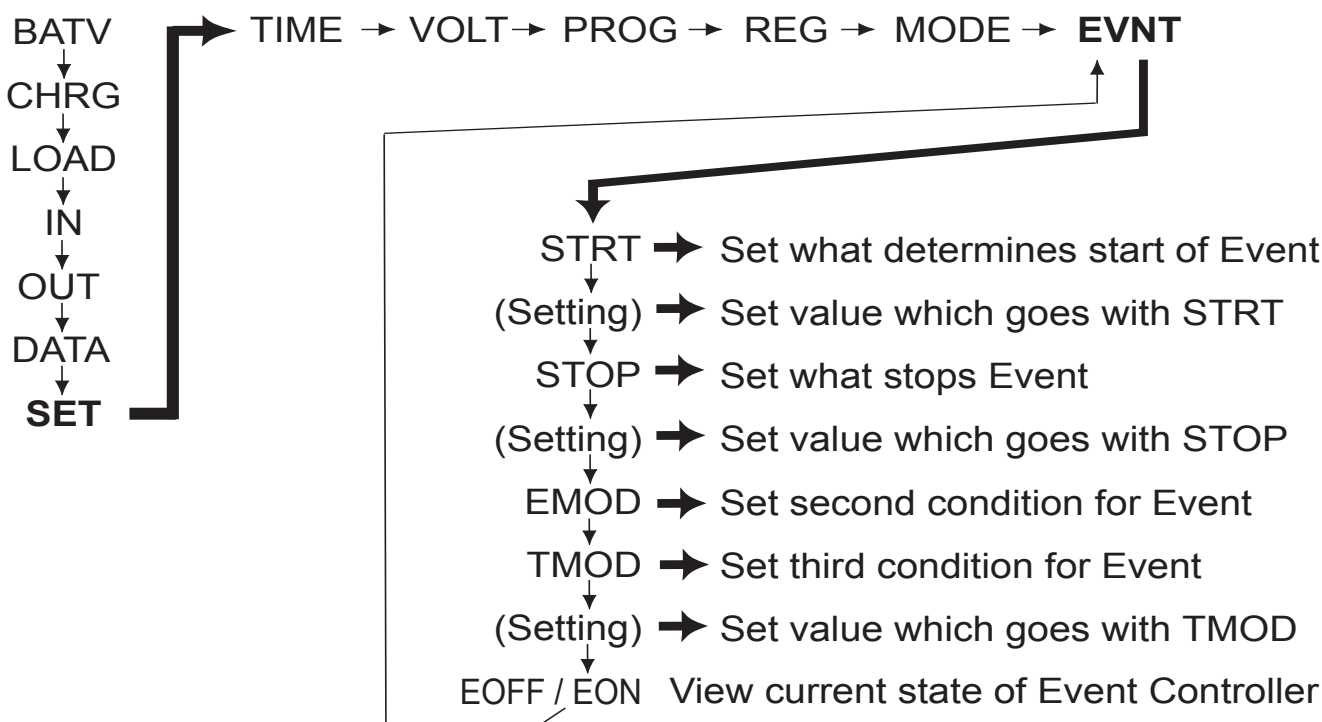

SET/EVNT/STRT Selection Summary

STRT	Event starts when	Value to set
0	Always starts	-
1	Time > setting (0.0-23.9)	TIME
2	Solar panel voltage (open circuit) > setting #	SOLV
3	Solar panel voltage (open circuit) < setting #	SOLV
4	External voltage VEXT * > setting	VEXT
5	External voltage VEXT * < setting	VEXT
6	PB** is on and time > setting	TIME
7	PB** is off and time > setting	TIME
8	Repeat start at 10 min intervals if time > setting	TIME
9	Repeat start at 30 min intervals if time > setting	TIME
10	Repeat start at 1hr intervals if time > setting	TIME
11	Repeat start at 2hr intervals if time > setting	TIME
12	Battery voltage > setting	VBAT
13	Battery voltage < setting	VBAT
14	Repeat start at a set rate (0-240 min)	RATE
15	Repeat start at a set rate (0.0-24.0h)	RATE

#Note: After up to 1 min delay if the solar charge switch has not turned off.

* Note: The user can select where VEXT is measured. If BSET is set to 2, then VEXT is the voltage measured by the B- sense input (relative to BAT- in the positive direction). The maximum VEXT measurable this way is 23V. If BSET is not 2, then VEXT can be measured by a bus accessory,

**Note: "PB" means a push-button switch. If you wish to use this option, you can wire a switch or other contact closure device between the B- sense terminal (green terminal block) and the BAT-terminal, and select BSET = 2.

Step 4

Select a STOP setting in this table to tell the Dingo what signifies the end of the "event". After setting the STOP value, a short-push will move you to the associated setting. For example, if you set STOP to '1', you will see 'TIME'.

Once started, the "event" will then continue until the time reaches the time you specify in the TIME setting. To allow events which go past midnight, there are special rules.

SET/EVNT/STOP Selection Summary

STOP	Event stops when	Value to set
0	Stop never active	-
1	Time > setting (0.0-23.9)	TIME
2	Solar panel open circuit voltage > setting #	SOLV
3	Solar panel open circuit voltage < setting #	SOLV
4	External voltage VEXT * > setting	VEXT
5	External voltage VEXT * < setting	VEXT
6	PB** on and time > setting	TIME
7	PB** off and time > setting	TIME
8	Repeat stop at 1 min intervals if time > setting	TIME
9	Repeat stop at 3 min intervals if time > setting	TIME
10	Repeat stop at 6 min intervals if time > setting	TIME
11	Repeat stop at 12 min intervals if time > setting	TIME
12	Battery voltage > setting	VBAT
13	Battery voltage < setting	VBAT
14	Stop after a set run time (0-240min)	RUN
15	Stop after a set run time (0.0-24.0h)	RUN

#Note: After up to 1 min delay.

*Note: "VEXT" has the same meanings as in the STRT table.

**Note: "PB" has the same meanings as in the STRT table.

For the combinations (start=1 and stop=1) or (START=1,6-11 and TMOD=8) then events can be active in a time period crossing midnight. If the stop time (or TMOD=8 setting) is less than the start time, then the controller assumes that the stop time is on the next day.

If the stop condition is to be ignored, select STOP=0 (stop condition is never active.)

NOTE: an event will not start if the stop condition is active when the start condition becomes active. In other words, stop has priority over start.

Step 5

Next, short-pushes bring the EMOD setting and then the TMOD setting. These settings can be used to set more conditions, which must be true for the event to be active.

For example, the EMOD setting could be used to ensure the light only turns on if the Dingo is in the Float state (EMOD=1).

If additional conditions are not needed, they can be set to zero and they will be disregarded (always active).

SET/EVNT/EMOD Selection Summary

EMOD	EMOD is active when:	LBD
0	Always active (EMOD condition is irrelevant)	Y
1	Dingo is in Float mode	Y
2	It's night	Y
3	It's day	Y
4	The external D* input is active	Y
5	Dingo is in Float and it's night	Y
6	Dingo is in Float and it's day	Y
7	In Float & external D* active	Y
8	Always active	N
9	Dingo is in Float mode	N
10	It's night	N
11	It's day	N
12	The external D* input is active	N
13	Float and it's night	N
14	Float and it's day	N
15	Float & external D* active	N

*Note 'External D' will come from a bus accessory

For settings 0 to 7, the low battery disconnect (LBD) function will override the EMOD condition and make EMOD inactive if the load should be disconnected. This makes it possible to disable an event if the battery voltage is too low.

Settings 8-15 are the same as 0-7 but without the LBD override.

SET/EVNT/TMOD Selection Summary

The TMOD setting provides an extra adjustable test condition

TMOD	TMOD is active when	Value to set
0	Always active (TMOD irrelevant)	None
1	temperature > setting	TEMP
2	temperature < setting	TEMP
3	battery voltage > setting	VBAT
4	battery voltage < setting	VBAT
5	*VEXT > setting	VEXT
6	*VEXT < setting	VEXT
7	Time > setting	TIME
8	Time < setting	TIME

* Note: VEXT depends on the setting of BSET.

If BSET=2, then VEXT is the voltage on the B-sense terminal. (This voltage is relative to the BAT-terminal in the positive direction [max 23V]).

If BSET is less than 2, then VEXT is an external voltage read by a bus accessory.

After setting the TMOD value, a short-push will move to the associated setting, as for STRT and STOP.

Step 6

Finally, a short-push displays a screen, which shows the current state of each of the conditions, and whether the "event" is currently active.

If the "event" is inactive, then to turn it on all three conditions (STRT, EMOD and TMOD) must become active (i.e. show as "1").

When the "event" is active, if the STOP condition takes place or the TMOD or EMOD condition goes inactive (ie "0"), then the event will turn off.

If the display shows "E ON" then the "event" is currently active. If it shows "EOFF" then the



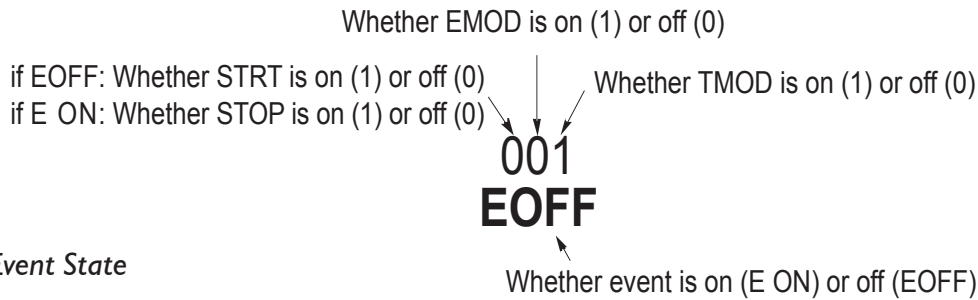

Fig. 7.7A - Event State

“event” is currently not active, but will become active when all of the preset conditions are met.

The numeric figure shows the state of each of these conditions.

The first digit shows the status of the STRT and STOP conditions. If the event is off (EOFF), the first digit shows the state of the STRT condition (0 = inactive, 1 = active). If the event is on (E ON) the first digit shows the state of the STOP condition. In the example, above, this figure will be “0” during the day (i.e. STRT condition is inactive), then “1” at dusk when the solar panel voltage drops to the pre-set SOLV value. If the battery was fully charged, the event will start, the display will change to “E ON” and the first digit will flick back to “0” to show that the STOP condition is inactive. If the battery was not fully charged, the event will not start, the display will stay on “EOFF”, and the first digit will remain on “1” until either the Dingo enters the Float state (when the event will start), or 11pm comes (when it will flick to 0 until next evening).

The second digit shows the state of the EMOD condition. In the example above, this digit will be “1” when the battery is in the Float state, and “0” if it is in the Boost, Equalise or Absorption states.

The third digit shows the state of the TMOD condition. In the example above, TMOD was not used, and this digit will always be “1”.

Examples:

1. To turn a light on all night

STRT	STOP	EMOD	TMOD
0	0	2	0

The first two conditions have the effect of making STRT and STOP irrelevant. The STRT

condition will always be on, and the STOP condition will never happen.

In practice, the EMOD condition will determine whether the event is on or off. Because it is set to 2, it will be on at night. If a light is wired to the LOAD terminal and LSET=4, then the light will turn on at night. (The light would also turn off if the battery voltage drops low enough for the LBD function to operate)

2. Pushing a button turns a light on at night for 10 minutes:

STRT	TIME	STOP	RUN	EMOD	TMOD
6	0	14	10	2	0

If a momentary ON push-button is wired up between B-sense and BAT-, the STRT condition will turn on with the push-button input (the time will always be greater than 0). It will stop after 10 minutes due to the STOP and RUN settings. EMOD=2 makes sure that this will only happen at night - during the day, pressing the push-button will have no effect. Note: The user also needs to set BSET=2 & LSET or GSET=4

3. Pump water if battery is fully charged until tank is full (i.e. switch in tank turns off):

STRT	STOP	TIME	EMOD	TMOD
0	7	0	1	0

The STRT condition is always true. The STOP condition becomes true when a float switch in the tank (wired between the Dingo’s BAT- and B- sense terminals) switches off (open), i.e. the tank is full.

To add the ‘fully charged condition’, EMOD is set to 1. This requires the controller to be in the

float condition (i.e. almost fully charged) before the EMOD condition will become active.

When the Dingo enters Float state, EMOD will become active and, as STRT is always true and TMOD is always true, the pumping will start if the tank is not full. .

Note: BSET=2, LSET or GSET=4

4. Water garden for 5 minutes every 100 min from 2pm until nightfall

STRT	RATE	STOP	RUN	EMOD	TMOD	TIME
14	100	14	5	3	7	14.0

The STRT condition is true every 100 minutes, i.e. repeated start at 100 minute intervals. The STOP condition causes the event to run for only 5 minutes after each event start. This cycle will continue while it is daytime (EMOD = 3) and it is after 2pm (TMOD = 7, TIME = 14.0).

Note: LSET or GSET = 4 and BSET=0.

8.0 Setting up a Larger System

The Dingo can become a controller for a larger system. By adding switching stages larger charge and load currents can be controlled.

Up to 12 external switch devices can be controlled. These attach to the serial communication port. This is a balanced 2 wire (RS485) bus running a communication protocol compatible with Modbus systems.

As well, up to 4 external current sensors can be added to allow measurements from other charge sources or loads to be included in the total system measurements. This might be a backup generator or an inverter.

8.1 Reading 'External' information

The charge or load currents from devices plugged into the bus are called 'external' or EXT for short. They appear in the charge, load, IN and OUT displays after the internal (i.e. actually going through the Dingo) readings. Because the current from an external device might be in either the charge (into the battery) or load (out of the battery) direction, the external devices appear in

both the charge and load displays. In the case of an external generator, the charge display would show the generator current and the load display would always be zero. In the case of an inverter/charger, the current could either be in either direction and either the load or charge will be non zero depending on direction.

8.2 Controlling external switches

An external switch device must be controlled by something. The Dingo allows each switch to be controlled by one of these four internal functions.

1. The battery charge controller
2. Low voltage load disconnect
3. Alarm
4. Event Control

If the external switch is a maximum power point tracker, then it is only controlled by the charge controller. The charge controller sends the MPPT the target voltage and the current battery voltage. The MPPT then tries to achieve the desired target voltage.

Selection of control for on/off switches is done in the SET/MODE/ESET menu (see section 7.5.3). It is necessary to set the control for each external switch attached. Because it is sometimes necessary for the switch to work in the opposite sense to normal, it is possible to select the inverse of each control. (e.g. for shunt regulation)

The switches are numbered 1 to 9 then A, B and C.

When a switch is being controlled by the charge controller it is turned on or off to try to maintain the controllers target voltage. The controller tries to reduce the amount of switching to a minimum to reduce any electrical interference caused by switching.

8.3 Connecting external devices

Each device connected to the controller must be discovered by the controller and given a number.

There are two ways to do this. Each device will have a means to set its own number. Each device must have its own number and no two numbers can be the same. When connected, the device will display information or be controlled according to that number.

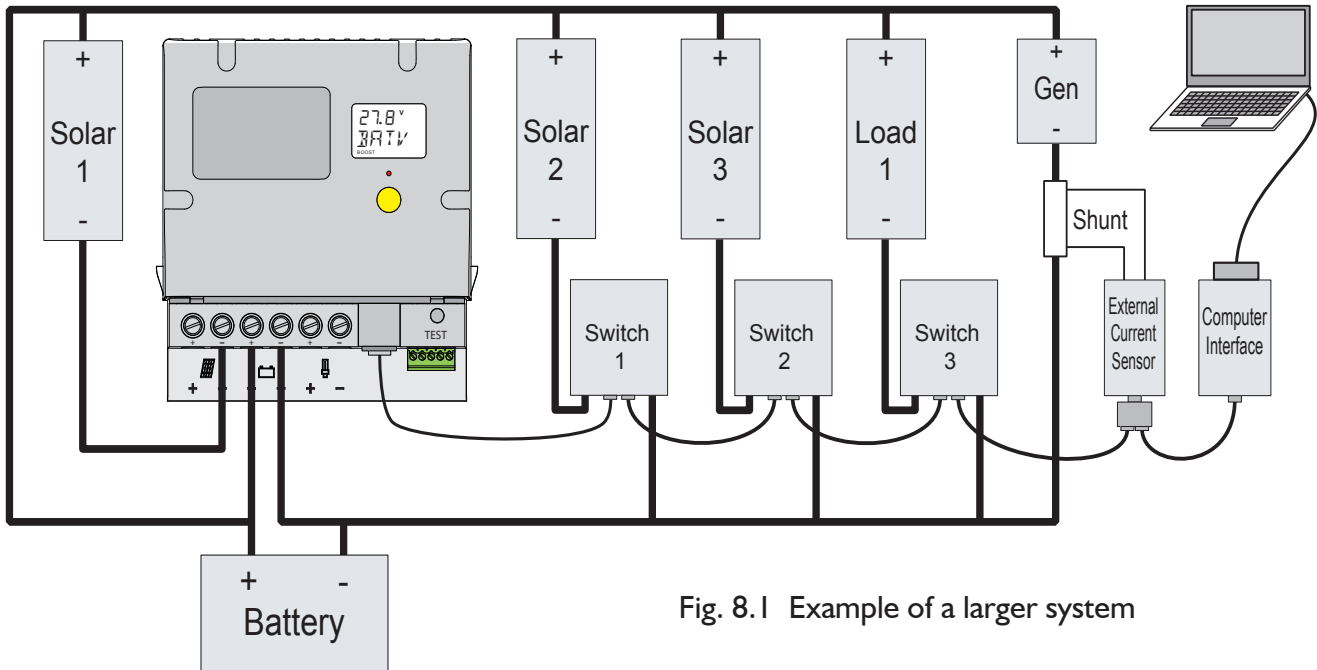

Fig. 8.1 Example of a larger system

It is also possible to have the controller discover each device and assign it a number based on the device's serial number. The lowest serial number will be given the lowest device number. The next lowest serial number will be given the 2nd lowest device number and so on until all devices have a number. This 'plug and play' system is selected by choosing the auto option on the external device (if it is available).

The connection of external devices to the serial bus is done with phone cable with modular plugs. These are 6P4C plugs (sometimes called RJ12). These loop through each device, either using the two sockets on the device or using a double adaptor for single socket devices.

8.4 Troubleshooting

If a current measuring device does not appear in the external list of devices then check the following things:

- If the device address selection is set to manual, check that two devices are not assigned to the same address number.
- Check the cabling to the device. If the cable has a plug on it that is the wrong way round, then it will not communicate.
- The discovery process can take a few minutes if a new device is added while the system is running.

A.0 Appendices

A.1 Accessories

There are accessories which can enhance the usefulness of the controller.

External Battery Temperature Sensor (DT or DTB)

The DT is a plastic-cased unit for direct attachment to the battery case. The DTB has a bolt-on lug for attaching to the battery terminal (either terminal).

The unit connects to the T+ and T- inputs on the green plug in terminal block under the wiring cover. See Section 7.4.3 for further details about this unit.

The following accessories plug into the serial port socket which is under the wiring cover.

External Shunt Adaptor (DSA)

Up to four external shunts can be added to the Dingo to allow it to measure larger currents than it is capable of measuring directly. The shunt adaptor measures the current in a shunt (eg SH200), converts it to digital information and sends that information back to the Dingo. The connection to the shunt is DC isolated from the Dingo so the shunt can be placed in any part of the circuit. Currents up to +/-250A can be read in 0.1A steps. See the DSA instruction sheet for more information.

Computer Serial Interface (DUSB)

A serial interface is available which allows the Dingo to communicate with a computer. It connects to the computer's USB port. The computer side is DC isolated from the Dingo side.

This is a quick way to load settings into the Dingo or extract performance data. All of the data is remotely accessible, and all settings can be adjusted. Software is available for IBM compatibles to make this easy. Data can then be loaded into a spreadsheet or other applications.

Modem Serial Interface (D232)

The serial interface is also available in a version designed for remote access via a modem. This uses an RS232 interface configured as a DTE device.

Ethernet Interface (DNET)

An ethernet interface is available which allows the Dingo to communicate with a computer or network or the internet. The network side is DC isolated from the Dingo side.

All of the data is remotely accessible, and all settings can be adjusted. It can also be accessed through a web browser or using SNMP.

Remote Control (DRC)

The Dingo can be accessed remotely with the remote control. All of the functions work in the same way as on the actual controller. Includes built-in audible alarm and display backlighting.

A.2 Specifications

Nominal system voltages	12,24,32,36,48	V
Maximum voltage BAT+ to BAT-	100	V
Max voltage BAT+ to BAT- for 1 minute	120	V
Maximum voltage SOL+ to SOL-	100	V
Max. voltage LOAD+ to LOAD-	75	V
Max. voltage between the "G" relay terminals	85	V
Max. voltage B- sense to BAT+	+/-30	V
Max. continuous charge current (SOL-)	40	A
Max. continuous load current (LOAD-)	40	A
Max. load current for 5 minutes	45	A
Max "G" relay current	300	mA
Battery Temp sensor range	-20 to +70	°C
Max. storage temperature	70	°C
Supply Current (Dingo only, 12V)	9	mA
Supply Current (Dingo only, 60V)	15	mA
Supply Current max (with acces.)	26	mA
Meter Accuracy	< +/-2% +/-2 display digits	
Max power wire entry size:	16mm ² (6 AWG)	
Wire size, Signal (Green) Terminal Block	0.2-1.3mm ² (26-16 AWG)	

A.3 The Alarm Led

The alarm led is used to indicate a number of different conditions. The states are

on, not flashing	battery voltage < alarm voltage
slow flash, mostly on	low battery disconnect in progress
slow flash, mostly off	load disconnected
fast flash	reversed solar connection indication on the test terminal

A.4 Current limits & thermal derating

Current limits/short circuit protection

The charge input has a current limit which acts to protect the Dingo from excessive charge current and can be used to protect small batteries from excessive charge rates. This is fixed at 40A for programs 0-3 and is adjustable in program 4 at the SET/REG/CLIM screen.

There is also short circuit protection. If the current out from the terminal exceeds 74A, then the charge switch is turned off. When this disconnection occurs, the boost annunciator will start flashing. It can be reset by a long push in the SOLV screen

The load output has a current limit. This acts to protect the Dingo from overheating due to excessive load current. If the load current exceeds 60A for the load disconnect delay time (LDEL) then the load will disconnect.

As well as this current limit, there is load short circuit protection. If the load current exceeds about 200A, the load switch is turned off immediately. If this occurs, the LOAD annunciator will start flashing. It can be reset by a long push in the LOAD/LINT/LSET screen

Thermal derating

The Dingo has an internal temperature sensor which acts to protect it from overheating. The charge current is reduced to limit the internal temperature. The ability of the Dingo to operate without reducing the charge current depends on five factors - the ambient temperature, the

load current, the time that it has been hot, the battery voltage and the number of external devices attached to the serial bus.. For example, it takes about 1 hour for the Dingo internal temperature to reach equilibrium under fully loaded conditions. It is difficult to construct a simple derating table because of these factors. The following information is a guide to what sort of performance can be expected in a number of situations.

1. 40A Charge current, 0A Load current, 12V battery, No external devices

The controller may operate at full current up to an ambient of 60°C (140°F)

2. 40A Charge current, 40A Load current, 48V battery, 10 external devices

The controller can operate at full current up to an ambient of 57°C (122°F)

If the ambient temperature is a few degrees above this, it can take an hour or more from cold before the Dingo will begin to limit the charge current.

3. Calculate the limit

It is possible to estimate the ambient temperature at which limiting will occur. This can be calculated from the following approximate formula.

$$T_{amb}(\max) = 70 - 0.0038(\text{charge current})^2 - 0.0031(\text{load current})^2 - 0.008(\text{battery voltage})$$

Where currents are in amps, temperature in °C.

(Valid for Tamb 45-60°C. Limiting may occur at or above this temperature

A.5 Block Diagram

This Dingo Controller is designed for common positive installations (i.e. solar and load circuits are switched on the positive side).

It has a reverse blocking mosfet switch between the SOL- terminal and the BAT- terminal and a mosfet switch between the LOAD- terminal and the BAT-terminal. There is also an optically isolated low current bi-directional mosfet switch between the 'G' terminals.

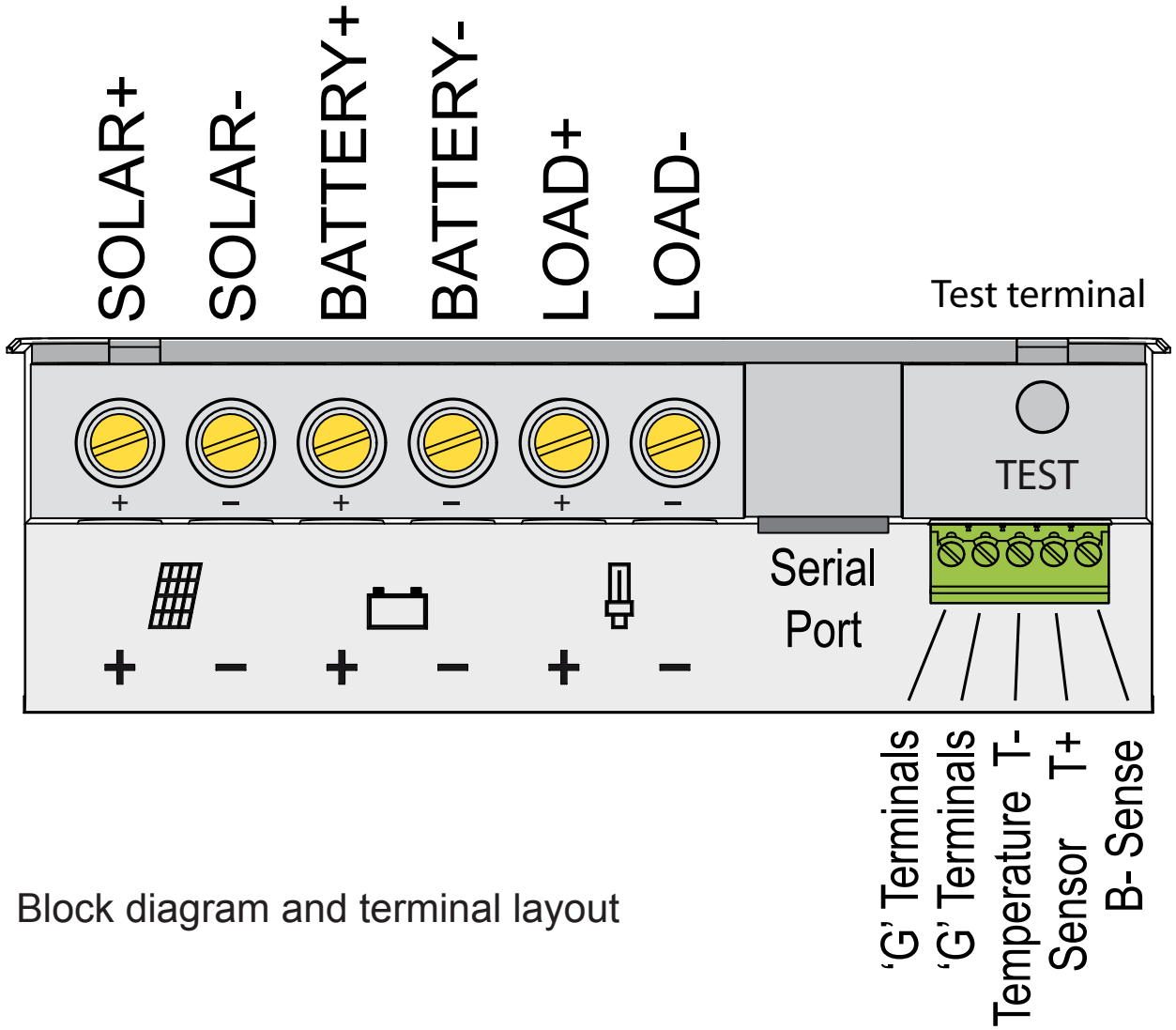

Block diagram and terminal layout

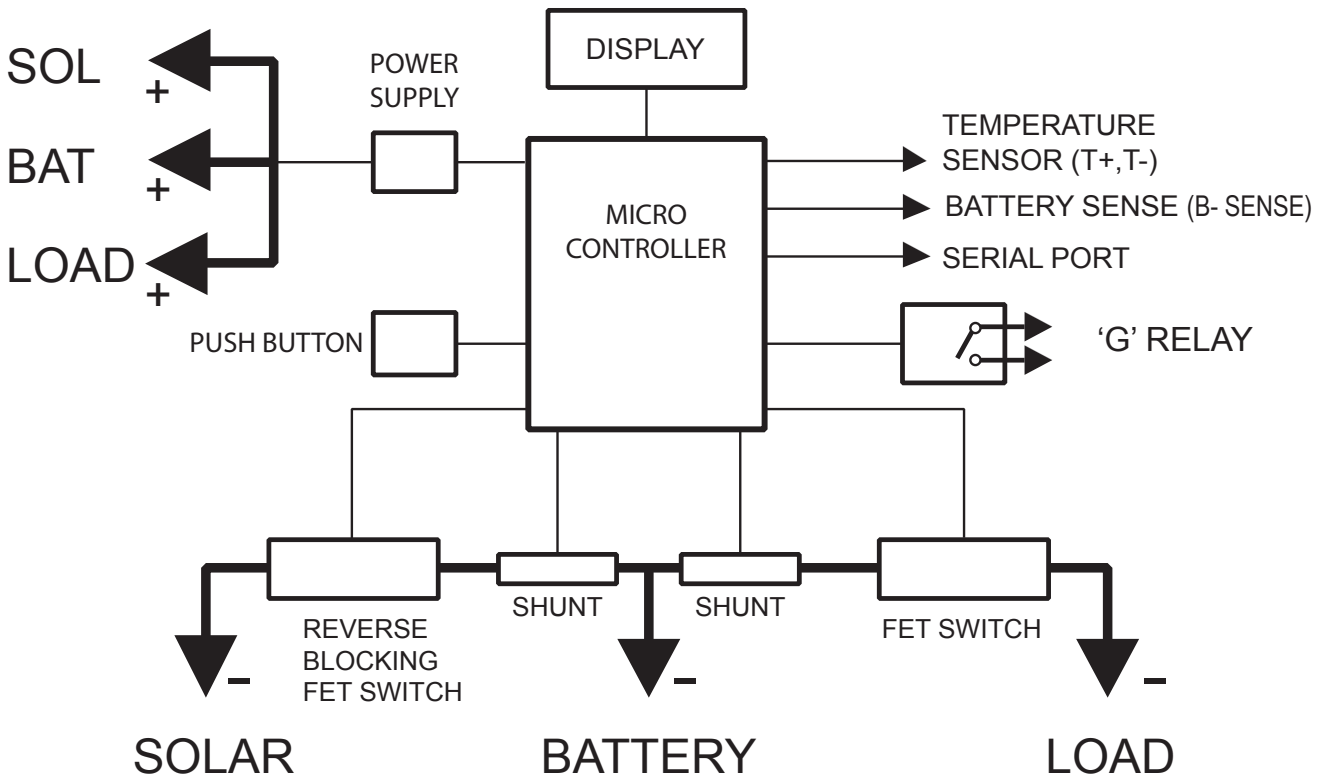

A.6 Mechanical Information

Material:	Case:	Polycarbonate
	Heatsink:	Anodised Aluminium
Weight (in box):		1.01kg (2.2lb)
Dimensions:		
Width		175mm (6.9")
Height		188mm (7.4")
Depth		57mm (2.2")
Mounting hole spacing horz		155mm (6.1")
Mounting hole spacing vert		130mm (5.1")
Mounting hole size		5mm (3/16")

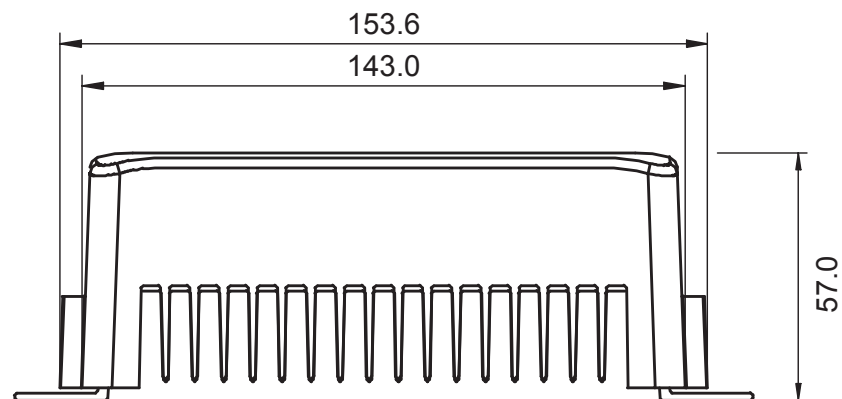
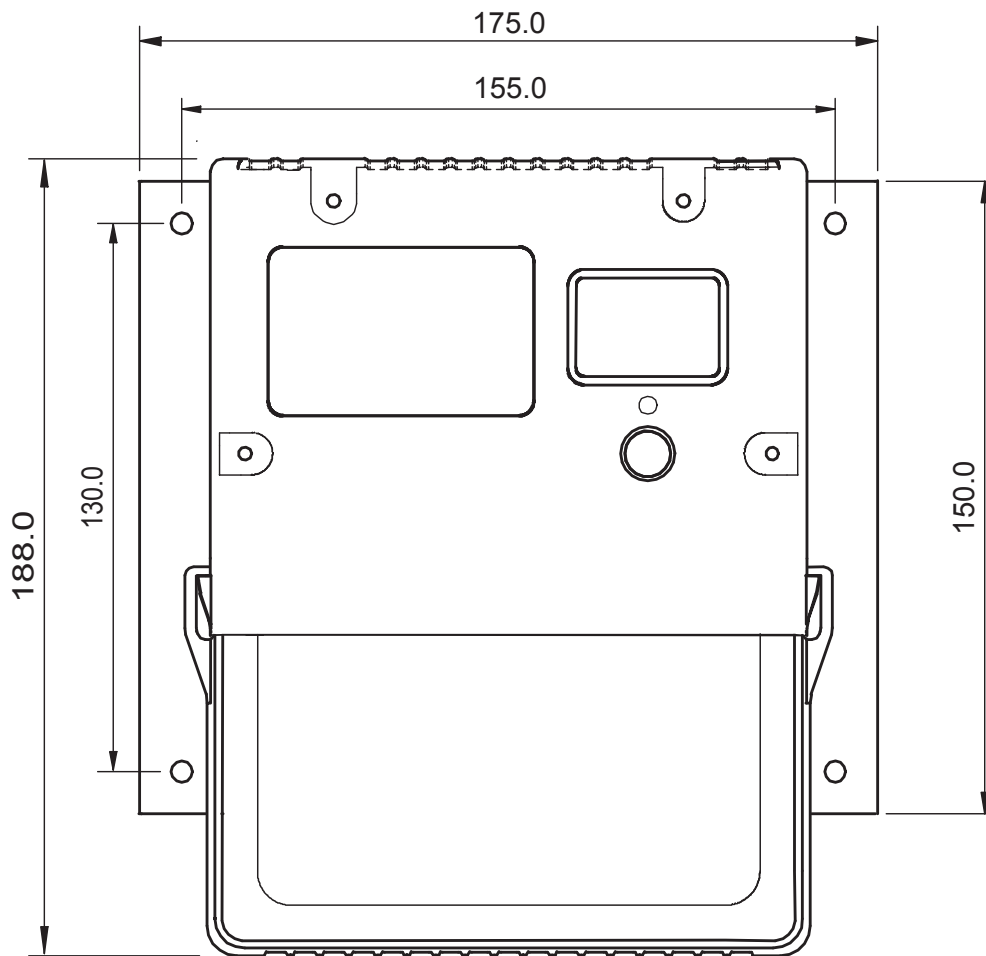

Dimensions in mm

Programs 0-3 Menu System (Programs with fixed settings)

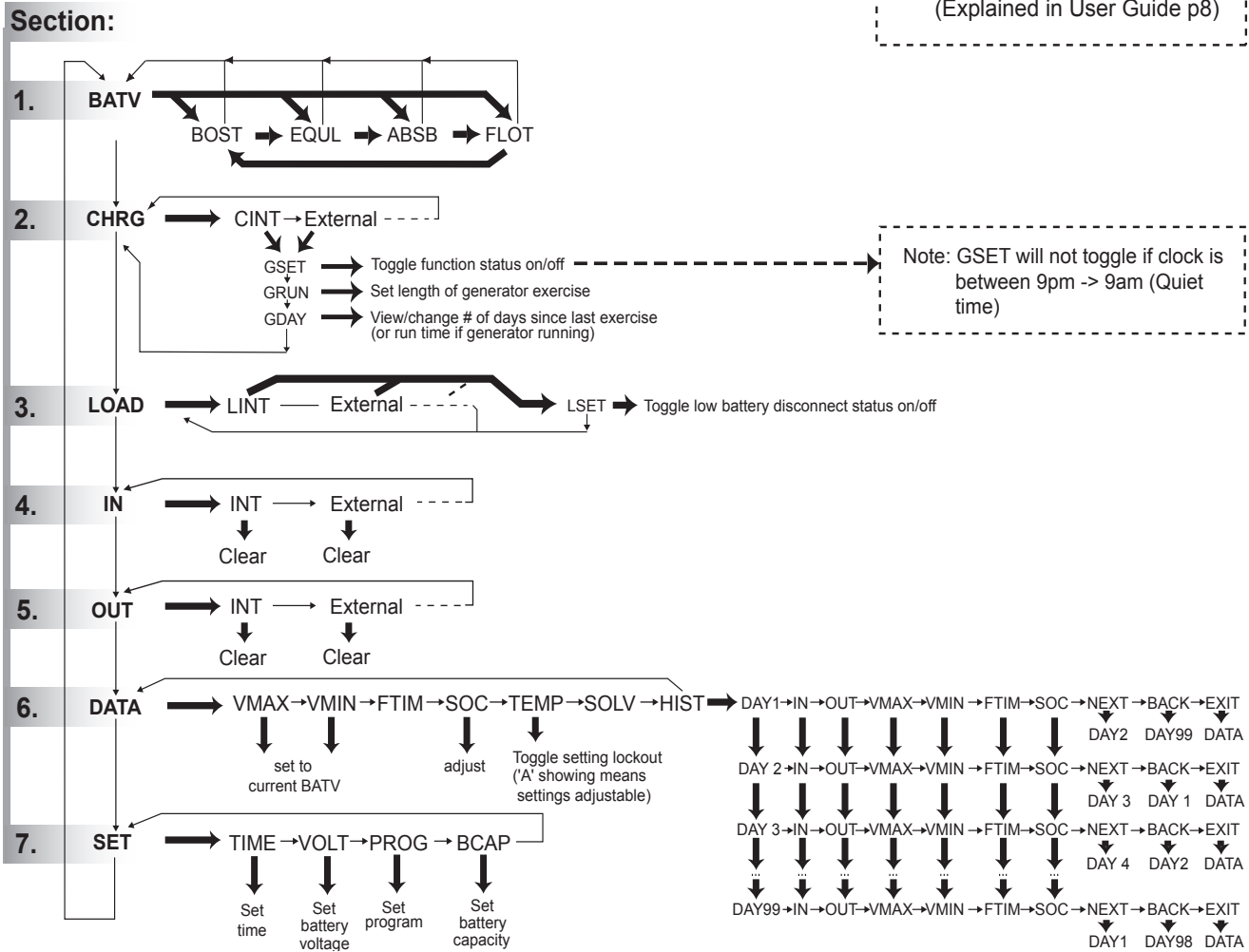
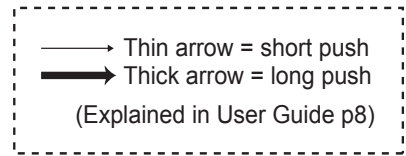

Legal Statement

The guarantee on this device extends to units operated within the limits described in the specification table.

Our liability under the guarantee is limited by the following conditions

Limitations

1. We reserve the right to repair or replace. The decision to replace is only to be made by us or one of our authorised agents.
2. We are not responsible for costs incurred by the user or installer in retrieving or reinstating a faulty unit.

3. We will not pay the cost of freighting faulty units to us or being returned from us.
4. We are not responsible for damage to other devices or property which may have occurred due to the failure of a unit.
5. While care has been taken to protect the device against lightning strikes, we will not honor the guarantee in respect of lightning damage.

Program 4 Menu System

(For adjustable settings)

→ Thin arrow = short push
 → Thick arrow = long push
 (Explained in User Guide p8)

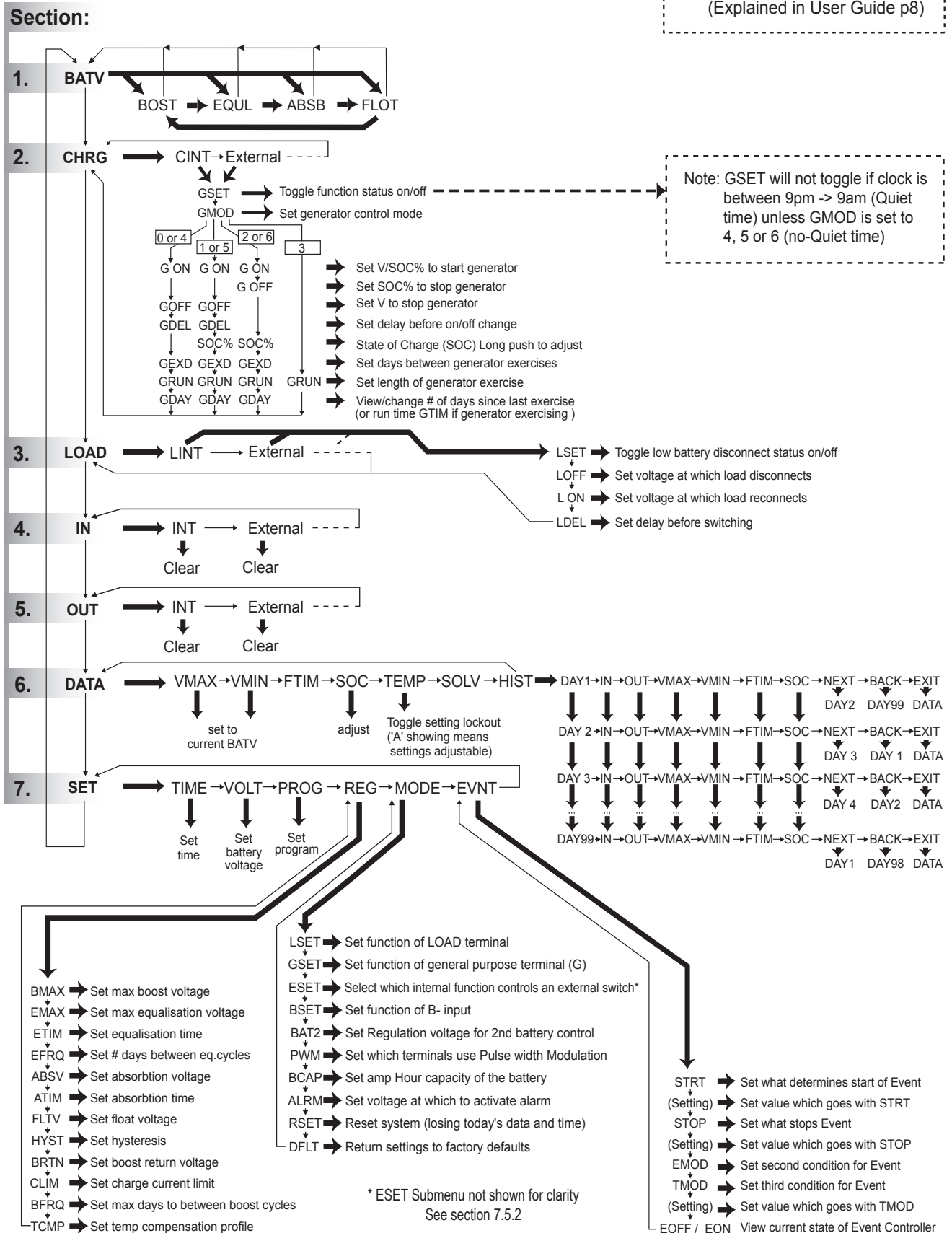

SYSTEM SETTINGS

Date: / /

Regulator Model: _____
 Serial No: _____
 Battery Type: _____
 Battery Capacity: _____
 No. of Solar panels: _____
 Wattage of panels: _____
 Total solar input watts: _____

Customer: _____
 Phone: _____
 E-mail: _____
 Address: _____

 State: _____ PostCode: _____

Other Comments: _____

CHRG menu settings:

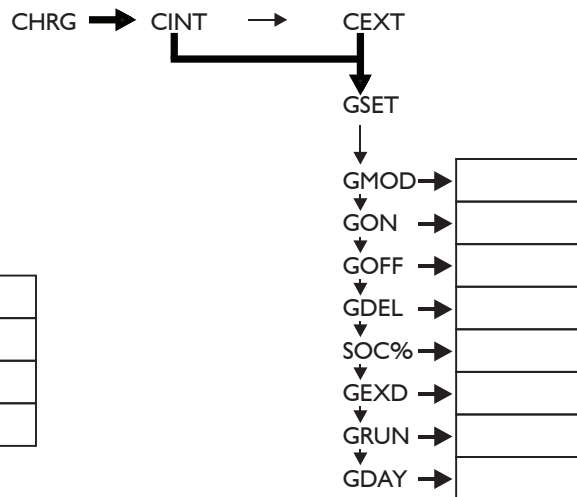

LOAD menu settings:

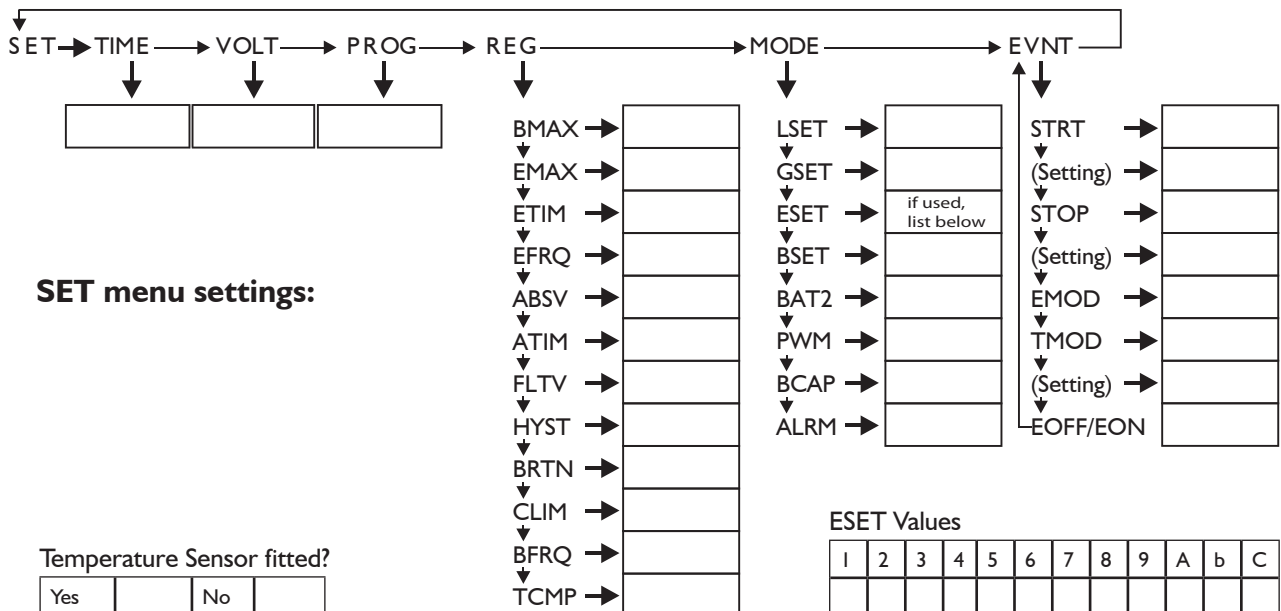
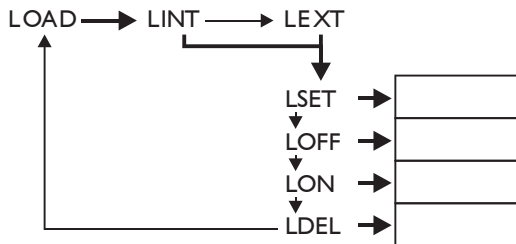

History Data

The following is the first 30 days of data stored each day in the history section of the DATA menu.

DAY		IN	OUT	VMAX	VMIN	FTIM	SOC	Customer:.....
No.	Date	Ah	Ah	V	V	h	%	Comments
1								(yesterday)
2								
3								
4								
5								
6								
7								
8								
9								
10								
11								
12								
13								
14								
15								
16								
17								
18								
19								
20								
21								
22								
23								
24								
25								
26								
27								
28								
29								
30								(30 days ago)



For further information visit www.plasmatronics.com.au

