

INSTALLATION GUIDE AND SPECIFICATIONS

NI PXIe-4844

This document includes the installation instructions and specifications for the National Instruments PXIe-4844 Optical Sensor Interrogator (OSI) module. The NI PXIe-4844 is a dual-slot, 3U PXI Express data acquisition module for fiber Bragg grating (FBG) optical sensors. The NI PXIe-4844 provides four optical channels that are simultaneously sampled at 10 Hz, and is expandable to eight or 16 channels with an external optical multiplexer.

FBG fiber optic sensing provides many benefits over conventional electrical sensing because it is nonconductive, electrically passive, and immune to EMI. FBG technology also enables measurements over long distances without loss of signal accuracy and provides the ability to daisy-chain dozens of sensors along a single optical fiber. The NI PXIe-4844 requires no calibration as it continuously adjusts its measurements using an on-board NIST traceable wavelength reference.

Safety Guidelines

Follow these guidelines when installing and using the NI PXIe-4844.



Caution Do not enable the laser unless an optical connector or LC/APC connector cover is connected to the LC/APC connector port. The laser enables when the device receives power.



Caution Never look into the end of an optical cable attached to an optical output when the device is powered on. The laser radiation is not visible to the human eye, but it can seriously damage your eyesight.



Caution Do not modify the NI PXIe-4844 module. This may result in hazardous radiation exposure from the laser source.

Electromagnetic Compatibility Guidelines

This product was tested and complies with the regulatory requirements and limits for electromagnetic compatibility (EMC) as stated in the product specifications. These requirements and limits are designed to provide reasonable protection against harmful interference when the product is operated in its intended operational electromagnetic environment.

This product is intended for use in industrial locations. There is no guarantee that harmful interference will not occur in a particular installation, when the product is connected to a test object, or if the product is used in residential areas. To minimize the potential for the product to cause interference to radio and television reception or to experience unacceptable performance degradation, install and use this product in strict accordance with the instructions in the product documentation.

Furthermore, any changes or modifications to the product not expressly approved by National Instruments could void your authority to operate it under your local regulatory rules.



Caution To ensure the specified EMC performance, operate this product only with shielded cables and accessories.



Caution To ensure the specified EMC performance when using the AUX port, install a snap-on, ferrite bead (National Instruments part number 781233-01) in accordance with the product installation instructions.

Unpacking

The product shipping kit includes the NI PXIe-4844 hardware module and the NI-OSI driver software DVD. The NI PXIe-4844 module ships in an antistatic package to prevent damage from electrostatic discharge (ESD), and the package is inside a hard-shelled plastic case. Before removing the hardware module from the antistatic package, touch the antistatic package to a metal part of your computer chassis to discharge any static electricity. Ground yourself using a grounding strap or by touching a grounded metal object.

Remove the hardware module from the package and inspect it for loose components or any signs of damage. Contact NI if the hardware module appears damaged in any way. Do *not* install a damaged module into your system. Store the module in the antistatic package and the hard-shelled plastic case when not in use.



Note When transporting the NI PXIe-4844 over long distances, remove the module from the chassis and place the module in the original antistatic package and hard-shelled plastic case.

What You Need to Get Started

- LabVIEW 2009 or later
- PXI Express chassis with
 - controller, *or*
 - MXI-Express (card or built-in)
- FBG sensors
- Multiplexer for additional channels (optional)

Installing the NI-OSI Driver Software

Install the NI-OSI driver software on the host computer *before* installing the NI PXIe-4844 module. Refer to `readme_OSI.html`, located in the `National Instruments\OSI Explorer` directory, for software installation instructions and system requirements.

Installing the NI PXIe-4844

This section contains installation instructions for the NI PXIe-4844. Refer to your PXI Express chassis user manual for chassis instructions and warnings.

1. Plug in your chassis before installing the NI PXIe-4844. The power cord grounds the chassis and protects it from electrical damage while you install the module.
2. Make sure the chassis power switch is turned off.



Caution To protect both yourself and the chassis from electrical hazards, leave the chassis powered off until you finish installing the NI PXIe-4844 module.

3. Touch a metal part on the chassis to discharge any static electricity that might be on your clothes or body.

4. Remove the protective plastic covers from the four front panel mounting screws on the module, as shown in Figure 1.

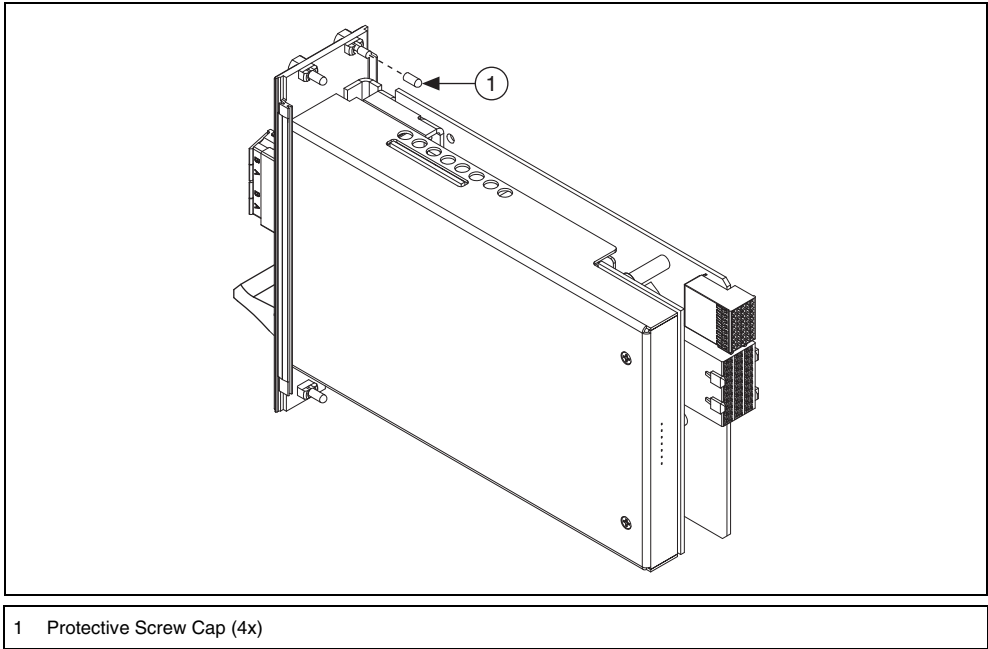

Figure 1. Removing Protective Screw Caps

5. Make sure the NI PXIe-4844 injector/ejector handle is in its downward position.
6. Identify two side-by-side empty chassis slots, except for a PXI Express System Controller slot. Of these two slots, the left-most slot must be one of the following PXI Express slots:
 - 8 PXI Express Peripheral Slot—a PXI Express slot marked with a solid circle containing the slot number.
 - 7^H PXI Express Hybrid Peripheral Slot—a PXI Express hybrid slot marked with the letter “H” and a solid circle containing the slot number.
 - 10 PXI Express System Timing Slot—a PXI Express timing slot marked with a square surrounding a solid circle containing the slot number.
7. Remove the filler panels covering the selected slots.
8. Align the NI PXIe-4844 with the card guides on the top and bottom of the selected slots.
9. Hold the injector/ejector handle down as you slowly slide the module into the chassis until the handle catches on the injector/ejector rail, as shown in Figure 2.



Caution When installing the module, make sure both edges are positioned inside the guides and that the module components do not come into contact with adjacent modules.

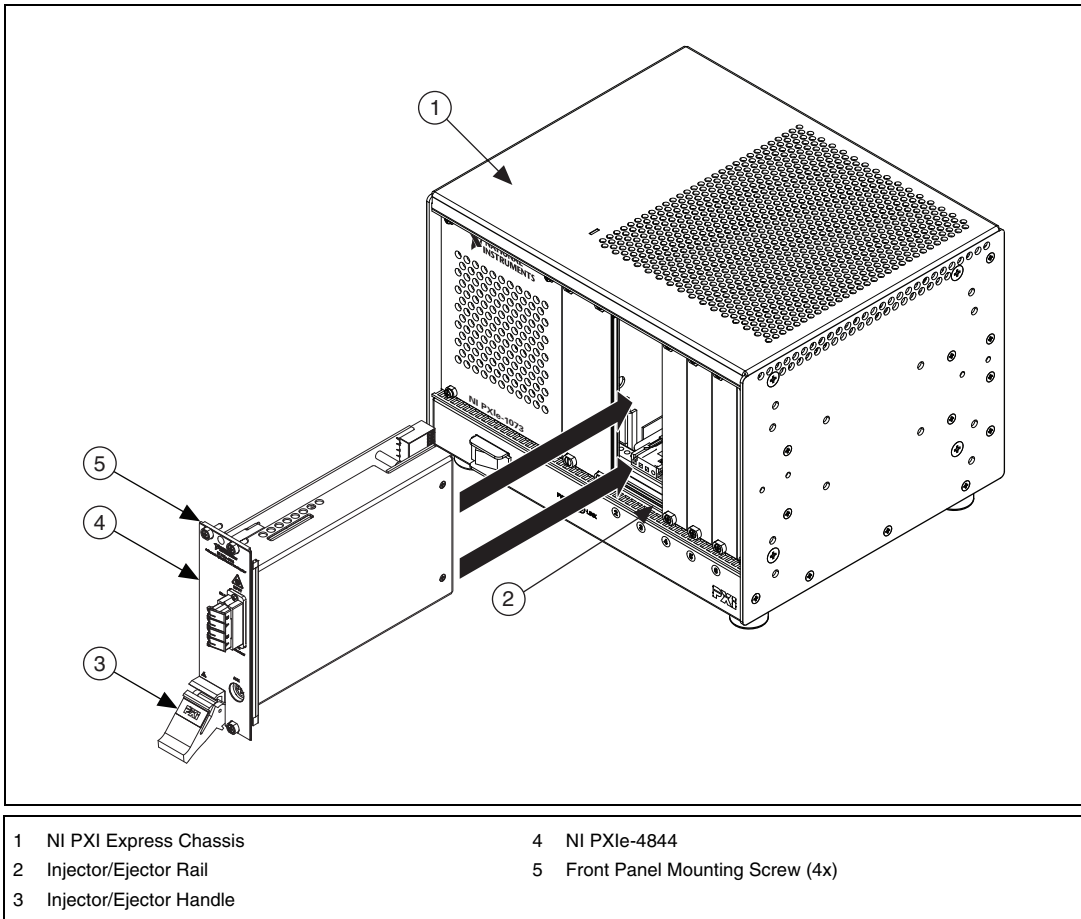

Figure 2. Sliding the NI PXIe-4844 into the Chassis

10. Raise the injector/ejector handle to latch the module into the chassis. The front panel of the NI PXIe-4844 should be even with the front panel of the chassis.
11. Tighten the four front panel mounting screws to 0.31 N · m (2.7 lb · in.) on the top and bottom of the module front panel to secure the NI PXIe-4844 to the chassis.
12. Power on the chassis.

Removing the NI PXIe-4844 from the PXIe Chassis

To remove the NI PXIe-4844 from the PXI Express chassis, complete the following steps:

1. Power off the chassis.
2. Remove any cables or sensors attached to the NI PXIe-4844.
3. Loosen the four front panel mounting screws on the module.
4. Press the injector/ejector handle down.
5. Slide the module out of the chassis.
6. Place the NI PXIe-4844 in its original antistatic bag. Store the module within its hard-shelled plastic case.

Connecting Sensors

The NI PXIe-4844 has four simplex singlemode LC/APC connector ports to connect sensors. If your sensor does not have an LC/APC connector, you need an adapter to connect the sensor to the LC/APC connector port.



Caution Connecting damaged or dirty sensors to the module can damage the LC/APC connector ports on the module. Always clean optical connectors before connecting to the module.



Caution Never force an optical connector into an LC/APC connector port. A ferrule may break and damage the module.

Connect the LC/APC connector on the sensor to an available LC/APC connector port on the module.

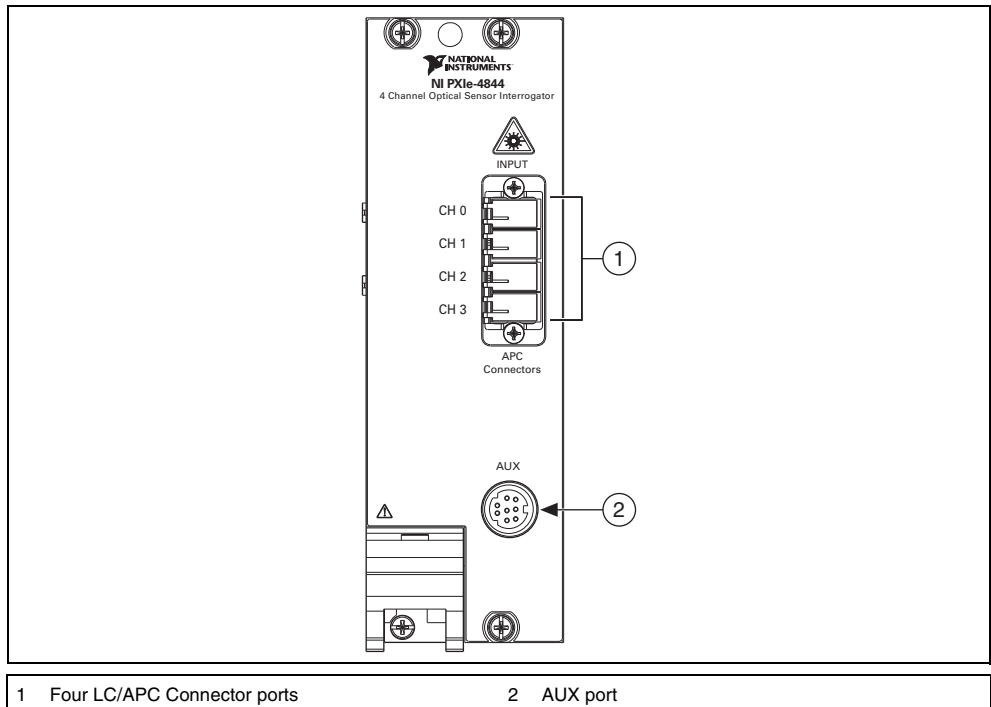

Figure 3. NI PXIe-4844 Channels and AUX Port



Caution When connecting any accessory to the AUX port, install a ferrite bead (NI part number 781233-01) on the connecting cable as close to the AUX port as possible. You can order ferrite beads directly from NI by part number by visiting ni.com/info and entering `partnumber`.



Note The AUX port is an 8-pin mini-DIN connector you can use to connect third-party multiplexers to the NI PXIe-4844. For more information on multiplexing the device, visit ni.com/info and enter `osimux`.

Cleaning Sensors

To clean the optical sensors, use a ferrule cleaner or follow the standard guidelines:

1. Fold a lint-free wipe into a compress.
2. Moisten the compress with isopropyl alcohol.
3. Remove the protective cover from the sensor connector.
4. Press the connector endface firmly to the moistened section of the compress, then forcefully wipe the connector with a twisting motion toward the edge of the compress, finishing in a clean, dry section of the compress. Do not reuse dirty sections of the compress.
5. Discard the used compress.

Calibration

The NI PXIe-4844 has continuous on-board calibration using epoxy-free Telcordia-qualified optical referencing components and continuous on-board NIST traceable wavelength reference components to ensure that sensor wavelength measurements remain within specifications over the life of the product.

Using the NI-OSI Explorer and LabVIEW VIs

The NI-OSI driver software installs the NI-OSI Explorer and the NI-OSI LabVIEW VIs. Use the NI-OSI Explorer to identify and configure the optical sensors connected to the NI PXIe-4844. Use the Optical Measurement VIs in LabVIEW to perform optical sensing measurements. To get started:

1. Select **Start»All Programs»National Instruments»NI-OSI Explorer»NI-OSI Explorer**.
2. Read the **Welcome** dialog. Follow the links provided for more information on configuring sensors and performing measurements.

Specifications

The following specifications are typical for the NI PXIe-4844 operating at 25 °C unless otherwise noted.

Bus Interface

Form factor.....x4 PXI Express, v1.0 compliant

Laser

Type.....Fiber laser

Class.....1

Output power (continuous wave)

Min.....0.06 mW

Max0.25 mW

Beam diameter9 mm (0.35 in.)

Numerical aperture0.1

Optical Input

Number of channels4

Wavelength range.....1510 nm to 1590 nm

Sample rate10 Hz \pm 0.1 Hz

Optical dynamic range40 dB

FBG Wavelength Detection

Accuracy	1 pm
Stability (0 °C to 55 °C).....	1 pm
Repeatability	1 pm

Physical Characteristics

If you need to clean the NI PXIe-4844, use a soft, non-metallic brush. Make sure that the device is completely dry and free from contaminants before returning it to the PXI Express chassis.



Note For two-dimensional drawings and three-dimensional models of the NI PXIe-4844 module and connectors, visit ni.com/dimensions and search by module number.

Dimensions (without connectors)	13.1 cm × 21.4 cm × 4.1 cm (5.1 in. × 8.4 in. × 1.6 in.)
Weight	213 g (7.5 oz)
I/O connector	LC/APC
Slot requirements	Two side-by-side chassis slots, other than a PXI Express System Controller slot. The left-most slot must be a PXI Express, PXI Express Hybrid, or PXI Express System Timing slot.
Slot compatibility	x4, x8, and x16 PXI Express or PXI Express Hybrid slots

Safety Standards

This product meets the requirements of the following standards of safety for electrical equipment for measurement, control, and laboratory use:

- IEC 61010-1, EN 61010-1
- UL 61010-1, CSA 61010-1



Note For UL and other safety certifications, refer to the product label or the [Online Product Certification](#) section.

Electromagnetic Compatibility

This product meets the requirements of the following EMC standards for electrical equipment for measurement, control, and laboratory use:

- EN 63126-1 (IEC 61326-1): Class A emissions, Basic immunity
- EN 55011 (CISPR 11): Group 1, Class A emissions
- AS/NZS CISPR 11: Group 1, Class A emissions
- FCC 47 CFR Part 15B: Class A emissions
- ICES-001: Class A emissions



Note For EMC declarations and certifications, refer to the [Online Product Certification](#) section.

Laser Compliance

This product meets the requirements of the following laser compliance standards for electrical equipment for measurement, control, and laboratory use:

- IEC 60825-1, ED 2.0, 2007-03; US CDRH 21 CFR Subchapter J

CE Compliance

This product meets the essential requirements of applicable European Directives as follows:

- 2006/95/EC; Low-Voltage Directive (safety)
- 2004/108/EC; Electromagnetic Compatibility Directive (EMC)

Online Product Certification

To obtain product certifications and the Declaration of Conformity (DoC) for this product, visit ni.com/certification, search by module number or product line, and click the appropriate link in the Certification column.

Shock and Vibration

Mechanical shock

Operating

(IEC 60068-2-7 Annex A,

section A.4, Table A.1) 15 g peak, half-sine, 11 ms pulse

Non-operating (IEC 60068-2-7) 25 g peak, half-sine, 11 ms pulse

Random vibration

Operating (ETSI 300 019-2-3)..... 0.15 g_{rms}, 5 to 100 Hz

Non-operating (IEC 60068-2-64) 0.8 g_{rms}, 10 to 150 Hz

Environmental

This device is intended for indoor use only.



Caution Do *not* exceed the operating temperature, even when using the module in a chassis with a higher temperature range.

Operating temperature

(IEC 60068-2-1, IEC 60068-2-2)..... 0 °C to 55 °C

Storage temperature

(IEC 60068-2-1, IEC 60068-2-2)..... -40 °C to 70 °C

Operating humidity (IEC 60068-2-56) 10% to 90%, noncondensing

Storage humidity (IEC 60068-2-56) 5% to 95%, noncondensing

Maximum altitude..... 2,000 m

Environmental Management

NI is committed to designing and manufacturing products in an environmentally responsible manner. NI recognizes that eliminating certain hazardous substances from our products is beneficial to the environment and to NI customers.

For additional environmental information, refer to the *NI and the Environment* Web page at ni.com/environment. This page contains the environmental regulations and directives with which NI complies, as well as other environmental information not included in this document.

Waste Electrical and Electronic Equipment (WEEE)



EU Customers At the end of the product life cycle, all products *must* be sent to a WEEE recycling center. For more information about WEEE recycling centers, National Instruments WEEE initiatives, and compliance with WEEE Directive 2002/96/EC on Waste and Electronic Equipment, visit ni.com/environment/weee.

电子信息产品污染控制管理办法（中国 RoHS）



中国客户 National Instruments 符合中国电子信息产品中限制使用某些有害物质指令 (RoHS)。关于 National Instruments 中国 RoHS 合规性信息，请登录 ni.com/environment/rohs_china。(For information about China RoHS compliance, go to ni.com/environment/rohs_china.)

Where to Go for Support

The National Instruments Web site is your complete resource for technical support. At ni.com/support you have access to everything from troubleshooting and application development self-help resources to email and phone assistance from NI Application Engineers.

National Instruments corporate headquarters is located at 11500 North Mopac Expressway, Austin, Texas, 78759-3504. National Instruments also has offices located around the world to help address your support needs. For telephone support in the United States, create your service request at ni.com/support and follow the calling instructions or dial 512 795 8248. For telephone support outside the United States, visit the Worldwide Offices section of ni.com/niglobal to access the branch office Web sites, which provide up-to-date contact information, support phone numbers, email addresses, and current events.

LabVIEW, National Instruments, NI, ni.com, the National Instruments corporate logo, and the Eagle logo are trademarks of National Instruments Corporation. Refer to the *Trademark Information* at ni.com/trademarks for other National Instruments trademarks. Other product and company names mentioned herein are trademarks or trade names of their respective companies. For patents covering National Instruments products/technology, refer to the appropriate location: **Help»Patents** in your software, the `patents.txt` file on your media, or the *National Instruments Patent Notice* at ni.com/patents. Refer to the *Export Compliance Information* at ni.com/legal/export-compliance for the National Instruments global trade compliance policy and how to obtain relevant HTS codes, ECCNs, and other import/export data.