

## HOTPOINT SERVICE OFFICES

If you have any trouble with your appliance, please call whichever of these numbers you think is applicable. It does not matter if you guess wrong: we'll make sure that the nearest Hotpoint Service Office tackles the problem.

### NORTH EAST

**N. Humbs, E. Yorks:**  
Tel: Hull 224777  
**S. Yorks:**  
Custom House Building, Whitefriargate, Hull  
Tel: Mекborough 582831  
**M. & W. Yorks:**  
Morphy Richards, Mекborough, South Yorkshire  
Tel: Wetherby 61444/61281  
**S. Durham, Cleveland:**  
Sandbeck Lane, Wetherby, West Yorkshire  
Tel: Mекborough 248436  
**M. Durham, Tyne & Wear, W. Thumberland:**  
59 Albert Road, Mекborough  
Tel: Newcastle 321008  
24 Northumberland Road, Newcastle upon Tyne

### NORTH WEST

**Cumbria, Lancashire:**  
Munford House, 28 Higglegate, Kendal, Cumbria  
Tel: Kendal 24483  
**Lancashire:**  
24/25 Cannon Street, Preston, Lancashire  
Tel: Preston 24311  
**Greater Manchester:**  
44/46 Salton Road, Heaton Mersey, Stockport  
Tel: St. Helens 35152  
**Merseyside:**  
40 Cowley Hill Lane, St. Helens, Merseyside  
Tel: 051-356 2141  
**Cheshire, Wirral:**  
1 Church Parade, Elmsmere Port, South Wirral

### S & W MIDLANDS

**Herefordshire:**  
Tel: Bristol 714471  
**Bucks, Bucks, Oxon:**  
3/5 Bristolton Hill, Bristolington, Bristol  
Tel: Didcot 817711  
224 Broadway, Didcot, Oxon  
Tel: Kidsgrove 74511  
**Staffs, Shropshire:**  
Tel: Aldridge 55641/55861  
West Avenue, Nelson Estate, Tulse, Stoke on Trent  
Worce, D. Barn, W. Mids:

### E. MIDLANDS

**Leics:**  
Tel: Leicester 29936  
De Winton House, Belgrave Gate, Leicester  
Tel: Lincoln 33611  
**M. Leics, S. Humbers:**  
Finn Road, Lincoln  
Tel: Peterborough 64741  
**S. Leics:**  
Tel: Mекborough 223869  
Celia Road, Filton, Peterborough, Cambs.  
**Northants, Warwicksh.:**  
399 Cambridge Street, Mекborough, Northants  
Tel: Nottingham 862481  
**Notm., Derby:**  
Ashby Street, Nottingham

### EASTERN

**Beds, N. Herts:**  
Tel: Luton 452211  
5 Cranley Road, Luton, Beds  
Tel: Northwick 620581  
**Northm., Suffolk:**  
92 Upper St. Giles Street, Norwich  
Tel: Peterborough 64741  
**Cambs, Hunts:**  
Celia Road, Filton, Peterborough, Cambs.  
Tel: Chelmsford 289331  
**Essex:**  
Industrial Buildings, Beehive Lane, Chelmsford, Essex

### LONDON & SOUTH EAST

**Middlesex, S. Herts:**  
Tel: 01-908 1933  
68 East Lane, Wembley, Middlesex  
Tel: 01-904 1280  
**London:**  
68 East Lane, Wembley, Middlesex  
Tel: 01-643 0921  
**Surrey:**  
2 St. Nicholas Road, Sutton, Surrey  
Tel: Haslemere 842733  
**Sussex:**  
1 Kingswood, North Street, Haslemere, Sussex  
Tel: Maidstone 76571  
**Kent:**  
Larkfield Trading Estate, New Hythe Lane, Larkfield, Kent

### SOUTH WEST

**Glouce, Avon, Wilts, Somerset:**  
Tel: Bristol 714471  
3/5 Bristolton Hill, Bristolington, Bristol  
**Cornwall, Devon:**  
Tel: Plymouth 282831  
69 Muley Plain, Plymouth  
**Hampshire, Dorset:**  
Tel: Southampton 861981  
South Hampshire Industrial Park, Salisbury Road, Totton, Hants.

### SCOTLAND

**Glasgow, Highlands:**  
Tel: Aberdeen 642283  
Hoback House, 68 Garden Place, Aberdeen  
**Tayside, Fife, Perth:**  
Tel: Dundee 28383  
Benneman House, South Tay Street, Dundee  
**Glasgow, Highlands, Borders:**  
Tel: 031-554 1431  
West Powmill Green Street, Perth, Edinburgh  
**Strathclyde, Dumfries, Galloway:**  
Tel: 041-886 6241  
West Lodge Road, Bynesswood Estate, near Perth

### WALES

**North Wales:**  
Tel: Degeany 82826  
Conwy Road, Llandudno Junction  
**Mid & S. Wales:**  
Tel: Bridgend 64121  
18 Western Avenue, Bridgend Industrial Estate, Bridgend, Mid-Siamongran

### IRELAND

**Northern Ireland:**  
Tel: Belfast 647111  
256 Ormeau Road, Belfast 7  
**Eng.:**  
Tel: Dublin 759922  
35/36 Arvan Quay, Dublin 7

Sometimes a number is changed when an edition of this booklet is still current. So if you get no reply from one of these, either try another of the numbers shown here, or see under 'Hotpoint' in your telephone book.

Hotpoint Ltd., Peterborough, England, PE2 9JB.

# How to use your Hotpoint Fridge

## Models 8211 and 8212

Please read right through this instruction book before using your fridge for the first time.

### ELECTRICAL REQUIREMENTS

All Hotpoint appliances come complete with a fitted plug. The plug on your fridge has a 13A fuse. If the plug does not fit your sockets, a new plug can be fitted. Cut off the old plug and throw it away, do not insert it into a socket elsewhere in the house as this could cause a shock hazard.

#### WARNING: THIS APPLIANCE MUST BE EARTHED.

#### IMPORTANT: Fitting a Different Plug:

The wires in the mains lead are coloured in accordance with the following code:

Green and Yellow – Earth  
Blue – Neutral  
Brown – Live

If you fit your own plug the colours of these wires may not correspond with the identifying marks on the plug terminals. This is what you have to do:

1. Connect the green and yellow (Earth) wire to the terminal in the plug marked 'E' or with the symbol  $\equiv$ , or coloured green or green and yellow.
2. Connect the blue (Neutral) wire to the terminal in the plug marked 'N' or coloured black.
3. Connect the brown (Live) wire to the terminal marked 'L' or coloured red.

With alternative plugs a 5A fuse must be fitted either in the plug or adaptor or in the main fuse box. In the event of replacing a fuse in the plug supplied, a 13A ASTA approved fuse to BS1362 must be fitted.

If the plug is the moulded on type the fuse cover must be refitted when changing the fuse. In the event of losing the fuse cover, the plug must **not** be used until a replacement fuse cover has been obtained and fitted. A new fuse cover can be obtained from your nearest Hotpoint Service Office or local Electricity Board. The colour of the correct replacement fuse cover is that of the coloured marks or insert in the base of the plug. **WARNING – Avoid accidents to children. When discarding an old fridge or freezer be certain to make the lock unusable.**

## WHERE TO PUT YOUR FRIDGE

Your fridge should be placed where it is easy to use, alongside or beneath a work surface is often a good position. Try to avoid putting it near anything which gives off heat, a cooker or radiator for example. If this is unavoidable an air gap of 10mm (1/2") must be left between the hot object and the fridge. In such a position your fridge will have to work harder and will cost more to run.

Once you have decided on the most suitable place, fit the two wall spacers supplied to the top of the black condenser (at the back of the fridge) and push the fridge back until the spacers are against the wall. This automatically ensures adequate air circulation at the back of the fridge.

If the fridge is placed underneath a work surface make sure that there is a gap of at least 20mm (3/4") between the top of the fridge and the underside of the work surface. If there is not enough clearance available, ventilation can be provided by fitting a special grille at the rear of your work surface. This grille, Part No. 256090, is available from your local Hotpoint Service Office (see back page).

If the fridge is to be located next to a freezer leave a gap of 50mm (2") between the two to avoid a build-up of condensation.

Finally, make sure your fridge is standing correctly by adjusting the two front feet until all four feet are in firm contact with the floor. Correct adjustment avoids excessive vibration and noise.

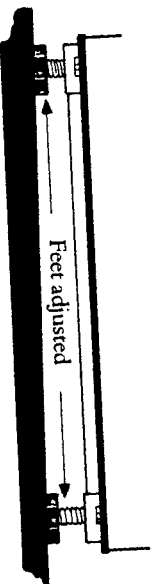

A Wheel Kit, Part No. 282268, is available from your local Hotpoint Service Office (see back page) for fitting to the back of your fridge.

**Note: You should not stack your fridge with any other appliance.**

## REPOSITIONING THE DOOR HINGE

Just follow the step by step instructions below:

### Tools required

A pointed knife, a 7mm and 8mm A/F Spanner and a No. 2 Pozidriv.

1. Take out all the loose fittings such as shelves, chiller tray and salad crisper from the inside of the fridge.
2. Carefully lay the fridge on its back (you may need assistance for this) using the original packing and keeping any pipework clear of the floor.
3. Unscrew and remove the two front feet (A).
4. Remove the clamping plate (B) and bottom hinge (C) by unscrewing the two screws (D). Make sure that if any packing washers (E) are fitted they are left on the hinge pin.
5. Remove the bottom screws (F), washers and plate (G) and fit them on the opposite side of the cabinet, making sure the hole in the cabinet for the foot is not covered over.

## FIVE YEAR GUARANTEE

From the moment your fridge is delivered, Hotpoint guarantees it for FIVE YEARS.

During the five years all parts are completely free of charge, provided they are fitted by Hotpoint's own Service Engineer. Labour costs are chargeable after the first year.

**Our FIVE YEAR GUARANTEE** also covers loss of food up to £250 in the first year.

This guarantee does not cover accidents, negligence or power cuts. The fridge must be used in the United Kingdom and must not be tampered with or taken apart by anyone who is not an authorised Hotpoint representative. Hotpoint's guarantee in no way limits your legal rights.

### Loss of food cover

You can choose to extend the cover for loss of food for a further four years after the first year. If you wish to enjoy the benefit of Hotpoint's Extended Food Cover please fill in the enclosed application card and send it, with your remittance, to your nearest Hotpoint Service Office, addresses shown on the back page.

### Proof of purchase

For future reference please attach your purchase receipt to this booklet and keep it in a safe place.

In accordance with its policy of progressive product design, the Company reserves the right to alter specifications.

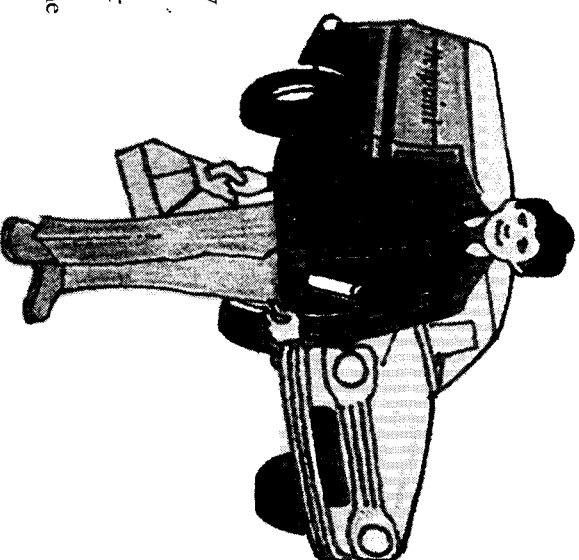

## WHAT TO DO IF ANYTHING GOES WRONG

Just run through these quick checks before calling your local Hotpoint Service Office.

1. Check that the plug is firmly in the wall socket and that the power supply is on.
2. Check the power supply to the socket by plugging in another appliance.
3. If the other appliance works, check the fuse in the refrigerator's plug.
4. If you have changed the plug, check the wiring (see page 1).
5. If there is excessive noise or vibration, check that all four feet are firmly in contact with the ground (see page 2).
6. If the interior light fails to work, refer to page 9 for further instructions.

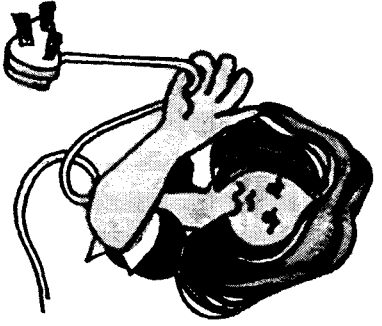

If, after following all these instructions, you are still having problems, contact your nearest Hotpoint Service Office (or local importer if outside the United Kingdom). The telephone number is shown on the back page.

When you contact us we need to know:

1. Your name, address and post code.
  2. Your telephone number.
  3. Clear and concise details of the fault.
  4. The model number (8211 or 8212), and colour.
  5. When it was purchased. Please put the date here .....
  6. If you have taken out the Hotpoint Five Year Loss of Food Cover (see opposite page).
- Make sure you have all these details before you call.



6. Remove the door by gently pulling it downwards until clear of the top hinge.
7. Remove the top hinge (H) by unscrewing the two screws (J) – replace the screws (J) but not the washer (K). Make sure the screw heads do not protrude below the recess.
8. Remove the two screws (L) in the opposite recess and use them to fit the top hinge (H), with the washer (K) on top, in the recess. Tighten the screws so that they are just gripping the hinge.
9. Before refitting the door, the plug (M) and the top and bottom hinge bushes (N) must be swapped over. Prise them out of their location, taking care not to mark the adjacent surfaces. Reposition them on the opposite side of the door.
10. Reposition the door handle insert (P) on the opposite side of the door. To do this, remove the four screws (R) and swap over the insert. Refit the four screws.
11. Refit the door by laying it on the cabinet and, sliding it upwards, locate the top hinge bush on the top hinge pin. Adjust the position of the top hinge so that the door fits evenly.
12. With all the packing washers that may have been originally fitted (E) retained on the pin, fit the bottom hinge pin (C) into the hinge bush (N). Adjust as necessary so the door fits evenly.
13. The bottom hinge can now be secured to the cabinet using the clamping plate (B) and two screws (D). The clamping plate should be fitted with the long straight side facing the outside edge of the cabinet and the large hole towards the rear of the cabinet.
14. Replace both adjustable front feet (A) setting them at approximately 25mm (1") from the bottom of the cabinet.

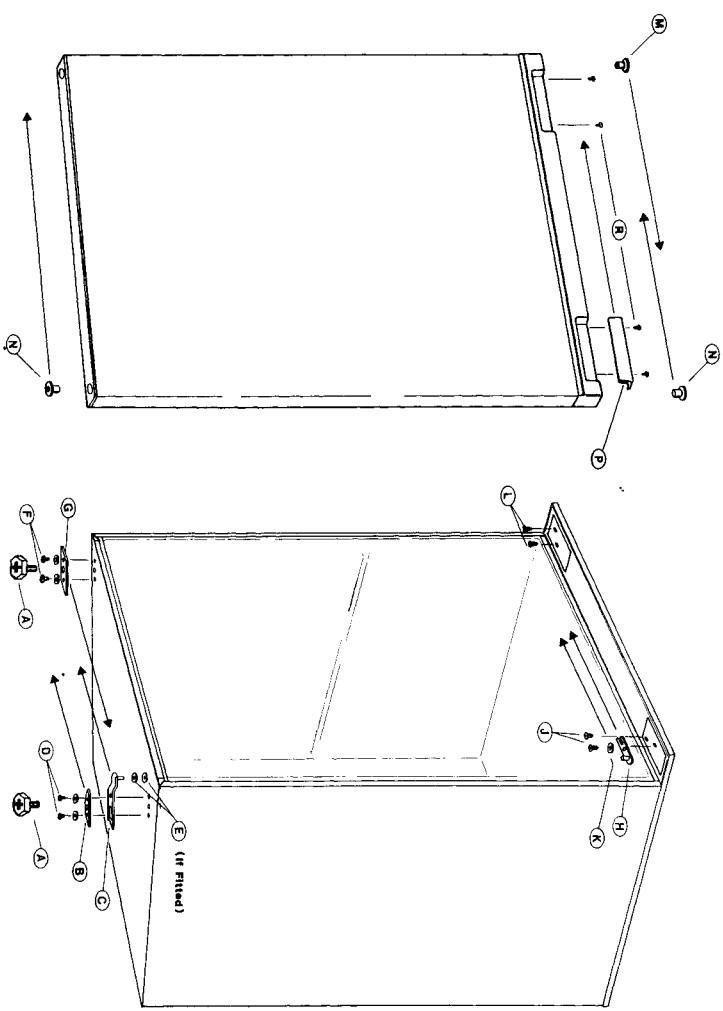

15. Stand the fridge up and put it where you have decided to locate it. Ensure it is standing correctly by adjusting the two front feet until all four feet are in firm contact with the floor.
16. Check the door opens and closes easily. **Ensure the door seal does not bind on the hinge side and that there are no gaps allowing air into the cabinet. Adjust the hinges if necessary.**
17. Tighten the top hinge screws.
18. Finally put back all the loose fittings inside the fridge.

## GETTING THE FRIDGE READY FOR USE

Before using your fridge for the first time, the interior, including the door, and all removable parts should be wiped out. Use a damp cloth wrung out in either a solution of one teaspoonful of bicarbonate of soda to one pint of water or Milton diluted according to the manufacturer's instructions.

**WARNING:** Never use any household cleaner or detergent, abrasive powders or wax polish. These not only damage the surfaces, they also leave a smell in the fridge.

## Final Check

Before you start using the fridge, check that

1. it is thoroughly dry inside,
2. air can circulate freely,
3. the feet have been adjusted, i.e. all four are firmly on the ground.

## Starting

Insert the plug into the wall socket and switch on the supply. Open your fridge door and the light will come on. There is a control dial on the right-hand side of the fridge interior. Turning the dial clockwise from 'O' (off) will start the fridge working. You will hear a noise as the compressor starts up.

## Running-in the compressor

Your fridge is operated by a compressor which switches on and off in order to maintain the fridge's temperature. The compressor is a precision piece of machinery like a car engine, and requires a running-in period of up to two months. During this time the compressor has to work a little harder and this may result in more noise than usual.

## CONTROLLING THE TEMPERATURE

### Frozen food compartment

The control dial, on the right-hand side of the fridge interior, controls the temperature in the frozen food compartment and is marked 'O' (off), min ... 9. Which setting is selected depends on how long you want to store frozen food.

Your fridge gives you a two star  performance in the frozen food compartment. This is achieved by setting the control dial to 5 and allows you to store frozen food for up to one month. This is the most popular setting.

Clean the outside of the fridge, **but not the door seal**, with a damp cloth, using a small amount of detergent, followed by a wipe down with a clean cloth. Do not use an abrasive powder. **The rubber door seal must be cleaned with soap and water only as detergent will damage it.**

Finally, the compressor and condenser at the back of the fridge can be carefully cleaned. Use a brush or vacuum cleaner to remove any dust. Always check that the fridge is disconnected from the mains when doing this.

Remember to replace the mains plug and switch on after cleaning your fridge.

### Table top

This is designed to serve as an extra work surface, but be careful with it. Do not drop heavy objects on it and do not sit on it!

### Going away

If you expect to be away for any length of time and don't want to use your fridge, switch off at the power point and pull out the plug. Remove all food and follow the defrosting instructions (see page 8). After defrosting wipe out the interior. Always leave the door ajar to prevent the accumulation of odours.

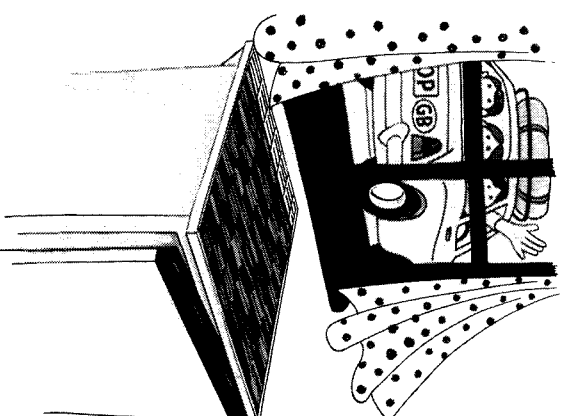

### How to replace the interior light

Should the light fail to work, **switch off and pull out the mains plug**, then ensure the bulb is screwed securely into the bulb holder. Replace the plug and switch on.

If the light still fails to work, do not worry, it will not affect the working of your fridge. Obtain a replacement SES 15 Watt bulb from a local electrical retailer or your nearest Hotpoint Service Office and then fit it as follows:

1. **Switch off and pull out the mains plug.**
2. Remove the shelves to make access easier.
3. Slacken off the lamp guard, undoing the pozidrive retaining screw by one turn.
4. Unclip and remove the lamp guard.
5. Unscrew the old bulb and fit the new one.
6. Refit the lamp guard, ensuring that the two legs opposite the retaining screw fit into the holes.
7. Retighten the retaining screw.
8. Replace the plug and switch on.

## CARING FOR YOUR FRIDGE

### Defrosting

#### Why and when:

Frost build-up reduces the efficiency of your fridge. It can also make closing the frozen food compartment door difficult. This is why you must defrost your fridge regularly. We recommend that you defrost your fridge once a week. Frost will build up more quickly in your fridge if you leave the door open or put warm food into it.

**Never** try to chip the frost away as you can easily damage the refrigerated surfaces of the frozen food compartment.

Defrosting is very simple but must be carried out as quickly as possible, particularly if you have frozen food in the frozen food compartment.

Just follow these steps:

1. Remove any frozen foods, wrap in several layers of newspaper and put in the fridge compartment or a cool place.
2. Remove the ice tray.
3. Move anything being stored in the chiller tray to the fridge compartment.
4. Close both flaps on the chiller tray.
5. Turn the frozen food control dial to 'O' (off). This switches the fridge off.
6. Place a bowl of very hot water in the frozen food compartment.
7. Leave the main door open.
8. After defrosting, empty the chiller tray, wipe it out and dry it.
9. Reset the chiller tray flaps to their original positions.
10. Replace the chiller tray and any food taken out of it.
11. Remove the bowl from the frozen food compartment.
12. Reset the frozen food control dial to its original position (see page 4).
13. Unwrap the frozen food and replace.
14. Refill the ice tray and replace.
15. Job done!

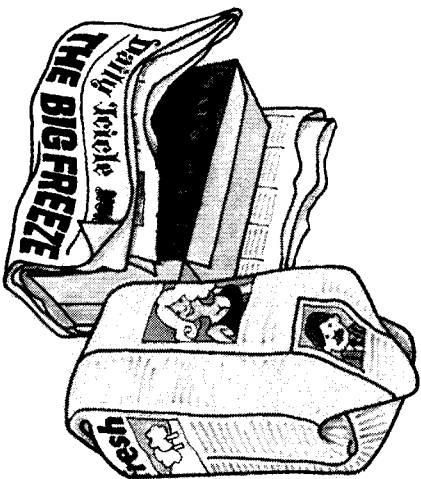

### Cleaning your fridge

It is a good idea to clean the inside of your fridge after defrosting. Always **switch off and pull out the mains plug** first. Wipe out the inside of the fridge using a clean cloth wrung out in either a solution of one teaspoonful of bicarbonate of soda to one pint of water or Milton diluted according to the manufacturer's instructions. The complete interior including the door, and removable parts, should be washed. Never use any household cleaner or detergent, abrasive powders or wax polish. These not only damage the surfaces, but also leave a smell in the fridge. Before you refill the fridge ensure it is thoroughly dry.

**Note:** Settings above 5 will only be required if the room temperature is very warm. You can reduce running costs by opting for a one star  setting. This is achieved by setting the control dial to 2 and allows you to store frozen food for up to one week.

### Fridge compartment

The temperature of your fridge compartment changes when you alter the temperature of the frozen food compartment. It is also affected by the location of the fridge, how often you open the door and the room temperature. The two flaps at the rear of the chiller tray control the amount of cold air that flows into the fridge compartment. The table below gives a guide to setting the chiller tray flaps.

Frozen Food Compartment Setting	Star Rating	Temperature	Suggested Flap Settings		
			Cool Room Temperature	Average Room Temperature	Warm Room Temperature
2	<input type="checkbox"/> *	-6°C (21°F) or colder	1 Open 1 Closed	1 Open 1 Closed	Both Open
5	<input type="checkbox"/> **	-12°C (10°F) or colder	Both Closed	Both Closed	1 Open 1 Closed

The chiller tray must be pulled out of the fridge in order to adjust the flaps. If further adjustments are necessary, proceed as follows:

#### Fridge compartment too warm:

Open one or both chiller tray flaps. If the fridge compartment is still too warm with both flaps open, turn the control dial to a colder setting (higher number).

#### Fridge compartment too cold:

Close one or both chiller tray flaps. If the fridge compartment is still too cold with both flaps closed, turn the control dial to a warmer setting (lower number).

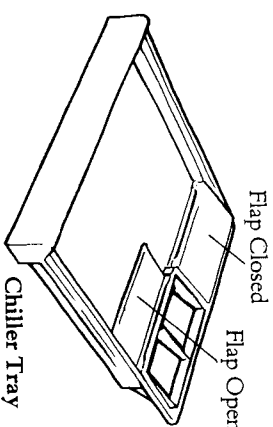

**Note:** In the summer months, or in conditions giving high temperatures around the fridge, the compressor has to work harder and run for longer periods. This is quite normal. Conversely, during cold weather, the compressor will run for much shorter periods.

## STORING FOOD

You can store most fresh foods in your fridge compartment. Recommended maximum storing times are given in the table below.

	Days
<b>Raw fresh meat</b>	3-5
joints, steaks, chops	
offal (liver, kidney etc) minced meat, sausages	2
<b>Cooked meat</b>	2-3
including made-up dishes and left-overs	
<b>Poultry</b>	2-3
fresh whole (store giblets separately)	
giblets	2
cooked	2-3
<b>Fish</b>	1-2
raw	
cooked	2-3
<b>Bacon</b>	7-10
<b>Milk, cream, salad; vegetables</b>	3-4

	Weeks
<b>Butter, margarine and cooking fats</b>	3-4
<b>Cheese</b>	3-4
hard	
cream	1
<b>Eggs</b>	2

All foods should be wrapped or covered to prevent drying out and flavour transference. Plastic bags, containers with lids, foil and plastic stretch wrap are ideal. Never put hot or warm food into your fridge as this reduces efficiency.

### Storing food in the frozen food compartment

You can store up to 3.7kg (8.1lb) in your frozen food compartment. Storage times depend on the setting you use and the type of food being stored. For best results always store pre-packed frozen foods in accordance with the frozen food manufacturer's instructions. Some packs will be marked with star markings matching those on the door of the frozen food compartment. Frozen food should be wrapped when bought and stored as soon as possible.

If you have set your frozen food compartment to give two star **\*\*** performance (setting 5 in normal conditions), you can store frozen food for the following approximate periods:

Sensitive Fruits (eg. Strawberries) .....	2 weeks
Fruits, Pastries, Dairy Products .....	3 weeks
Vegetables, Lean Meat, Ice Lollies .....	4 weeks

The exact period will vary with the nature of food stored.

If your frozen food compartment is set to give one star **\*** performance (setting 2) frozen food should not be stored for more than one week.

### Storing food in the chiller tray

You can store fresh food in the chiller tray, but you should remember three things:

- Do not allow it to touch the frozen food compartment or it will become stuck.
- It will tend to freeze as this is a very cold area.
- Do **not** attempt to store frozen food in this area, it is not cold enough to keep it fully frozen.

### Do's and Don'ts

#### DO

- Take off any unusable leaves on vegetables and wipe off any soil.
- Leave lettuce, cabbage, parsley and cauliflower on the stem.
- Wrap cheese tightly in cling film excluding as much air as possible. For best results take out of the fridge an hour before eating.
- Wrap raw meat and poultry loosely in polythene or aluminium foil. This prevents drying.
- Wrap fish and offal in polythene bags and store as close to the frozen food compartment as possible, the chiller tray is a good place, but follow the instructions on page 6.
- Wrap foods which have a strong odour, or can dry out, in polythene bags, aluminium foil or place in airtight containers.
- Wrap bread well to keep it fresh.
- Chill white wines, beer, lager and mineral water in the fridge compartment before serving.
- Wrap frozen food when you buy it and put it into the frozen food compartment as soon as possible.
- Empty and refill the ice tray periodically to ensure freshness.
- Store frozen foods in accordance with the instructions given on the packets that you buy.
- Defrost the frozen food compartment regularly (see page 8).

#### DON'T

- Store bananas in your fridge.
- Store melon in your fridge. It can be chilled for short periods as long as it is wrapped to avoid it flavouring other food.
- Wash eggs as this removes their natural protective film. Wipe them instead.
- Use eggs straight from the fridge, especially when making cakes or mayonnaise. Allow them to reach room temperature before use.
- Leave the door open for long periods as this will cause excessive ice formation and make the fridge more costly to run.
- Cover the shelves with any protective materials which may obstruct air circulation through them.
- Put liquid-filled bottles or sealed cans containing carbonated liquids (fizzy drinks, etc) in the frozen food compartment as they may burst.
- Try to keep frozen food which has thawed; it should be eaten within 24 hours or cooked and refrozen.
- Give children lollipops and water ices direct from the frozen food compartment. The low temperature may cause 'freezer burns' on their lips.