



USER'S MANUAL

Weld334m

HC

HCM

HIC

HIM

GF WELDING S.p.A.

Strada del Portone, 18/24 - 10137 - TORINO (Italia)

Tel.: 011-3033.278 (Italy Sales dept.)
011-3033.270-279 (Foreign Sales dept.)Tel.: 011-3033.277 (Italy After Sales)
011-3033.274 (Foreign After Sales)

Fax: 011-3092046

e-mail: mail@gf-welding.itweb: www.gf-welding.it

The information contained in this manual may be changed at any time without prior notice; in this case, GF WELDING S.p.A. is relieved of any responsibility.

The information on the software and hardware tools contained herein are confidential and are released in conformity with a licence contract.

It is absolutely prohibited to distribute or circulate the hardware and software documentation of this product to third parties.

The purchaser is allowed to prepare the software safety backup copy in the quantity of one copy only.

No part of this manual may be reproduced or distributed in any form or by any means or stored in a database or retrieval system without the prior written permission of GF WELDING S.p.A.

All rights reserved to GF WELDING S.p.A.

Table of contents

<i>WHITE PAGE</i>	VI
1. SAFETY	1
1.1 HAZARDS ASSOCIATED WITH THE USE OF RESISTANCE WELDING MACHINES	2
1.1.1 ! Prohibitions.....	2
1.1.2 ! Conditions to be respected to reduce the hazard	2
1.1.3 ! Causes of hazard.....	2
1.2 OBSERVATIONS ON CONNECTIONS.....	4
1.2.1 Earthing, insulation.....	4
1.2.2 Safety criteria against short circuits	4
1.2.3 Current sensor.....	5
1.2.4 Power supply.....	6
1.2.5 Phase synchronising for welding.....	7
1.2.6 Programming unit	7
1.2.7 Connecting the Weld334m with the WMS central network	7
2. CHARACTERISTICS AND GENERAL DESCRIPTION OF THE WELD334M	9
2.1 GENERAL DESCRIPTION	9
2.2 BLOCK DIAGRAM OF 334M	10
2.3 HARDWARE CONFIGURATION.....	11
2.4 CHARACTERISTICS.....	12
2.4.1 Utilisation characteristics	13
2.4.2 Dimensions, overall dimensions and fastening positions.	13
2.4.3 HHT4300 programming unit.....	14
2.4.4 Connection through Laptop	14
3. POWER SUPPLY AND 24V FOR I/O	15
3.1 CONTROL DEVICE POWER SUPPLY.....	15
3.1.1 PS . Description of signals	15
3.1.2 Connections for main power supply.....	16
3.1.3 Power consumption	17
3.2 USE OF 24V - I/O	17
3.2.1 Selecting 24V – internal or external.....	17
3.2.2 24V connections for discrete I/O.....	18
3.3 GENERAL PROTECTIVE DEVICES ON POWER SUPPLY.....	20
3.4 SETTING THE EXTERNAL SYNCHRONISM	21
4. F351-BUS INTERCONNECTION CARD	23
5. F384-CPU MICROPROCESSOR CARD	25
6. F353-ADC ANALOGUE CARD	27
6.1 P3 E P4 . DESCRIPTION OF THE ANALOGUE INPUTS.....	27
6.2 P2 . DESCRIPTION OF THE SIGNALS FOR THE SOLENOID VALVE AND THE TFE	28
7. F364-SEV AND F385-SEV: PROPORTIONAL SERVOVALVE MODULES	31
7.1 SERVOVALVE ADJUST:	31
7.1.1 Voltage outlet characteristics.....	32
7.1.2 Current outlet characteristics.....	32
7.2 CONNECTION OF THE F364 / F385-SEV MODULE ON THE F353-ADC CARD.....	32
7.2.1 Jumper function on connector J4	33
7.2.2 Jumper function on connector J5	33
8. F359-MCP MEMORY CARD AND PRINTER	35

9. F360-IOB CARD – BASE I/O	37
9.1 DESCRIPTION OF FUNCTIONS	37
9.2 P20 24VDC - I/O	37
9.3 P22 - HSA – CIRCUIT BREAKER TRIP.....	37
9.4 P21 . DESCRIPTION OF SIGNALS	38
10. F356-IOE I/O EXPANSION CARD	41
10.1 P23 . DESCRIPTION OF OUTPUT SIGNALS	41
10.2 P24 . DESCRIPTION OF INPUT SIGNALS.....	44
10.2.1 <i>List of program selection codes</i>	47
11. F376-OPC FIELD-BUS INTERBUS-S CARD (PROFILE F-IBS/03)	49
11.1 CHARACTERISTICS	49
11.2 OPTICAL CONNECTORS INTERBUS-S	49
11.3 INTERBUS-S INTERFACE POWER SUPPLY	50
11.4 DESCRIPTION OF STATUS LEDs.....	50
IDENTIFICATION CODE (ID CODE)	51
11.5 ERROR CONDITIONS WITH THE CONTROL DEVICE SHUT DOWN	51
11.6 OPTICAL POWER REGULATION	51
12. F386 ETHERNET 100BASE-T AND CANBUS COMMUNICATION MODULE	53
12.1 TECHNICAL FEATURES	53
12.1.1 <i>Ethernet section</i>	53
12.1.2 <i>CANbus section</i>	53
12.2 FRONT PANEL.....	53
12.2.1 <i>P28 – CANbus connector</i>	53
12.2.2 <i>CANbus status LED's</i>	53
12.2.3 <i>P10 Ethernet 100Base-T connector</i>	54
12.2.4 <i>Ethernet status LED's</i>	54
12.3 ETHERNET CONNECTION CABLE	54
12.3.1 <i>Features</i>	54
12.3.2 <i>Connection type</i>	54
13. F383-COM RS422 SERIAL COMMUNICATION CARD	57
13.1 P15 – CONNECTION PORT	57
14. INTERBUS-S PROFIL F-IBS/03	59
14.1 GENERAL DESCRIPTION	59
14.1.1 <i>Control Words</i>	59
14.1.2 <i>Status Words</i>	63
14.2 ROBOT DIRECTIVES UPDATE.....	66
APPENDIX	67
APPENDIX A - MAINTENANCE	69
<i>Maintenance operations</i>	69
Replacing the modular cards.....	69
Replacing the CPU card.....	70
Replacing the power feeder.....	70
Replacing the welding control device	71
Modifying a welding program.....	71
Replacing the battery	72
APPENDIX B – DIAGRAMS AND NETWORK CONFIGURATIONS	73
<i>Operating diagrams</i>	73
1 – START recognition with use in automated environment	73
2 – START recognition with use in manual environment	74
3 – EMERGENCY STOP condition : general diagram	75
4 – EMERGENCY STOP condition during or outside the welding pulse	76
5 – EMERGENCY STOP excluded with START still active	77
6 – START disabled condition during the welding pulse	77
7 – Proportional Servovalve operating diagram.....	78
8 – ENABLE function (Interbus-s)	79

9 – Diagram of diagnostic pressure control	80
<i>Interbus-S –general architecture of I/O communications.</i>	<i>81</i>
Ethernet Tcp/Ip – Example of network architecture	82
InterBus-S- Example of network architecture.....	83
<i>WHITE PAGE.....</i>	<i>84</i>
APPENDIX C - WELD334M APPLICATION DIAGRAM.....	85

WHITE PAGE

1. Safety

To insure correct installation and operation of the WELD334m welding control device, it is necessary to carefully read this chapter. Each operation on the machine is to be carried out only by qualified personnel with good understanding of the information contained in this manual; should the documentation not be perfectly legible and/or incomplete of any further information required, please consult GF WELDING S.p.A. before undertaking any work on the machine.

Inside the welding control, signals are generated which set parts of the machine in motion; therefore, it is prohibited to open and tamper with the control and safety circuits. Live metal parts, such as screws or similar parts, penetrating into the electric circuit may cause malfunctioning as well as the generation of incorrect and hazardous conditions and events.

It should be remembered that any changes and/or modifications not expressly authorised by the manufacturer or performed by unauthorised personnel or non-GF WELDING personnel which modifies the machine operation makes the warranty void.

Check all cables and the relevant connections before using the welding control device in order to see if there is any mechanical damage or failing insulation. Whenever a problem arises such as to compromise the safety conditions, switch off the unit and cut out power. Report the problem to GF WELDING **After Sales Personnel**.

To ensure the optimal performance of the device, the user must make sure that all requirements for safety on the work site are strictly adhere to.

1.1 Hazards associated with the use of resistance welding machines

Because of the presence of electric current and live parts in the machine, mounting, maintenance work and replacement of genuine parts is only to be entrusted to Qualified Personnel (electricians or authorised personnel). All work undertaken is to be done in safety conditions. The non-observance of these requirements can cause death, injury to persons or damage to machine and property.

1.1.1 ! Prohibitions

- It is prohibited to work on the live installation.
- It is prohibited to remove by-pass and modify the safety devices as this could cause serious risks to personnel and equipment and could lead to death.

1.1.2 ! Conditions to be respected to reduce the hazard

- Always insure that the electric switchboard main switch is OFF.
- Work on the machine, equipment and the welding transformer only after breaking the connection from the mains. This to be sure that no undesired switching of electrical current occurs.
- Work on the spotgun and welding cable connections only after breaking the connection from the mains power.

1.1.3 ! Causes of hazard

- The programming of the welding control is entrusted only to qualified personnel. Incorrect parameter settings may cause damage or injury because of undesired molten material splashes during welding.
- It is compulsory to wear protective goggles, non-flammable clothes and protective shoes.
- Dangerous conditions may arise when, for example, electrodes are changed or dressed and no current re-adaptation/re-setting takes place, especially when using the stepper function (stepper reset).
- If 24V power supply is external to the machine or the control device, power may be applied to the equipment even if the main switch connection is broken.
- During mounting, setting of work, maintenance and/or repair operations, hazards may occur because of the exchange of leads, air/water pipes, etc...
- Unqualified personnel may be unaware of the risk that such changes/modifications entail, therefore, all changes/modifications are only to be entrusted to and/or performed by qualified personnel.
- Hazardous situations may arise because of mains voltage drops, or in case of tripping of the machine emergency stop device, which causes the return to rest position of the pneumatic valves in use during the operation (this situation affects the whole plant).
- If during the welding process the cooling water flow is low or non-existent, it is prohibited to bypass or inhibit the tripping of thermostats or the water flow control device (if installed).

- High magnetic fields, generating very close to the welding gun and the secondary cable, represent a serious hazard to people and property (e.g.: watches, cables for electric data transmission, magnetic devices, medical equipment and pace-makers).
- Welding is obtained through the periodical repetition of high single-phase, short-time and low cosphi current pulses. These conditions of use may cause disturbances to the power lines of the production plant and may be hazardous for other types of operating machines or machine tools.
- Outputs of the welding control device solenoid valves are all protected by a series-connected contact of the cycle start relay. This to prevent any faults or disturbances of the electronic outputs from causing undesired controls. (The Start cycle function is equipped with a time-dependant consent control at the plants and countries demanding for it).
- In cases where local safety regulations require or prescribe such as for machine start – for instance: two-hand cycle start controls with check of simultaneous operation – these devices shall have to be implemented when installing the system.
- Outputs for the pre-stroke solenoid valves controlling the additional gun opening, feature direct control as well as the output for the proportional solenoid valve.
- These two outputs do not cause any movement nor do they operate the gun to close fully.

1.2 Observations on connections

1.2.1 Earthing, insulation

This paragraph deals with the earthing of the equipment, please ensure that all earthing is correctly carried out.

- The correct earthing of each part of the electric system is a compulsory precaution, in order to ensure the plant workers/operators safety.
- Furthermore, earthing is of paramount importance to avoid damage to the installation itself. Periodically check the status of earth connection of all cables and terminal cards.
- Special care is to be paid to connections with moving and metal parts, making sure there is no oxidation of connection and that the electrical connections are made against painted areas.
- To have correct earthing, it is fundamental to avoid series connecting the whole earth installation or part of it with only one cable. It is also important to check that, for each machine, the earth is star connected at the fixing point of the earth cable.
- Some types of welding machines need for the earth connection of the transformer secondary to be made outside of the machine.
- The Weld334m is a sophisticated, microprocessor controlled equipment which can also be used in environments showing «electromagnetic field pollution». In the design phase, systems have been adopted which respect the EMC requirements with the surrounding ambient. It is recommended to scrupulously observe the conditions of use (meaning by this that the Weld334m cabinet is to be closed and all its earth leads must be connected).
- In compliance with the accident prevention Standards, the welding control does not act directly on the SCR block; the SCR switching is operated through a special external firing circuit which is isolated from high voltage present on the power circuit.

1.2.2 Safety criteria against short circuits

On a welding machine, the short circuit is likely to occur on the transformer primary side. This may entail very serious consequences such as, for example:

- On a Robot or an automatic installation, the destruction of parts onto which the short circuit current is discharged.
- On a manual station, the electrical shock of the operator and damage to the equipment.

The short circuit may occur between the primary and ground or between the primary and the secondary.

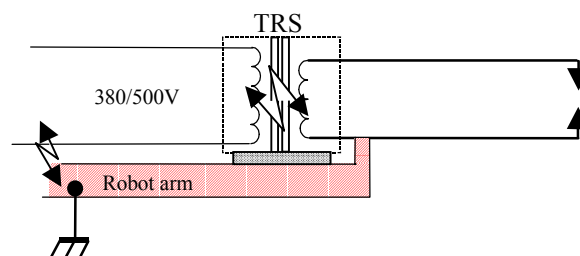

Here below are a few measures which are to be taken in order to avoid harm and damage to operators and equipment:

1. Earth the welding transformer secondary.
2. Install a differential on the welding transformer primary set to the minimum value of current (30mA).

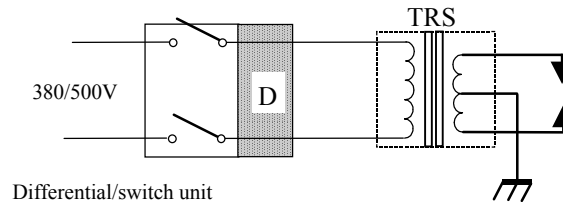

3. Use a safety device to monitor the value of voltage on the welding guns with respect to earth. This device should be linked to circuit breaker trip.

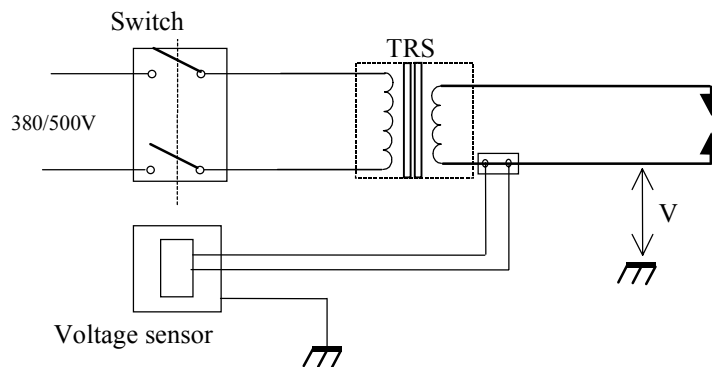

1.2.3 Current sensor

The current sensor, also known as current coil or Rogowsky coil, thoroid or, sometimes, more improperly, CT (current transformer), is the device by which the control device measures and adjusts the welding current during the welding process.

Irrespective of the specifications and standards of the electric transducer characteristics, a few fundamental rules are however to be applied concerning the position of the transducer and its relevant wiring. This to minimise errors due to electric and, mainly, magnetic disturbances.

The reliability and accuracy of the ammeter directly depend on the correct positioning as well as on the adequate protection against external disturbances.

If the sensor is built into the welding transformer, problems concerning the respect of a few of the Standards have already been solved in the transformer design phase.

As for sensor positioning, the following requirements are to be adhered to:

- The sensor is to be located in the welding secondary circuit.
- The plane to which the sensor is mounted must be orthogonal to the lead run through by current it measures, that is 90°.
- The sensor, if external to the welding transformer, must be placed as close as possible to the welding electrodes. Thus, maximum accuracy is achieved. However, this mounting position is not always possible. A good compromise lies in mounting the sensors in the rear part of the guns, near the cable adapter. Provide for protection against shocks. It can however be always placed at the transformer secondary output.

- The lead run through by current is to be placed in the middle of the thoroid.
- The sensor is to be placed as far as possible away from any edges or elbows of the secondary lead.
- As for the turn formed by the secondary circuit, it is necessary to mount the sensor in a position so that the distance between the go and return conductor be the maximum possible one.

As for the sensor connections, the following requirements are to be adhered to:

- The connection cable is to be tightly twisted and screened and is to be run as short as possible. In any case, its laying is to be done as far as possible away from sources of electrical or magnetic disturbances and it must not be run in parallel with the cable for welding component (primary + secondary).
- The cable screen must be bonded on only one side of the welding control, whereas no sensor end is to be bonded.
- Accurately avoid joints or provisional connections between the sensor and the connector of the welding control in order to minimise any inductive and capacitive effects. If possible, minimise the quantity of interruptions (terminal boards and/or plugs).
- Do not use fuses on the current sensor conductors.

The rules cited above are to be observed by all users carrying out installations and wiring as well as by those who design and manufacture electric switchboards in cabinets, transformers and other equipment which are somehow associated or associable to current sensors. The non-observance of these rules entails loss of accuracy and repeatability in the welding process with constant current control device. In addition, this could cause serious malfunctioning.

- It is recommended to use current sensors featuring 150 mV/kA /1k Ω sensitivity and with a 20-25 Ω internal resistor (these can be ordered from GF WELDING S.p.A.)
- The Weld334m permits using up to 6 sensors in series (one at a time is active when welding). The quantity of sensors connected is to be set on the welding device (see Programming manual, Setup chapter).

1.2.4 Power supply

Depending on the configurations, the Weld334m input can be both direct current and alternated current (See operating characteristics).

One assumes that power supplied to the system is «clean», meaning it is free from electrical disturbances and showing no voltage drops.

In case of AC, it is recommended to use a power/insulation transformer with earthed electrostatic shielding.

1.2.5 Phase synchronising for welding

To have correct welding operation, the device is to be synchronised with the same power phase as the SCRs it is piloting.

Considering the power supply features of the device, synchronising may take place in a different manner, depending on the following cases:

- If powered from the Ac mains, it is sufficient for the transformer powering the device to be connected with the same power phase as SCRs.
- If powered from a power line other than that of SCRs or DC powered, the sync. signal must be taken from the power side through an insulation transformer. For the use of the external synchronism, see paragraph 3.4

The non-observance of these rules will cause **serious malfunctioning**.

1.2.6 Programming unit

Great care is to be paid to the switching on and off of the HCM 4300 HHT graphic programming unit.

The input port can be damaged both because of a short circuit during the connection work and further to electrostatic charges. Put the HHT metal casing in touch with that of the Weld334m before installing the connector. This will discharge the static charge.

Make sure no foreign bodies, such as metal chips or slags, fall inside the connector.

Any damage to the HCM 4300 HHT graphic programming unit and to the Weld334m, resulting from tampering or deliberate disregard, will void the guarantee.

1.2.7 Connecting the Weld334m with the WMS central network

To centralise the welding zones, GF WELDING has developed a program called WMS (Welding Management System). All control devices installed in a given welding zone can be accessed directly through a serial line linked to a PC.

The program permits interacting with all control devices and, at the same time, controlling the whole welding process of the zone concerned.

Communication is performed through: the WMSNet associated to an RS485 multidrop network, or PROFIBUS FMS or ETHERNET TCP/IP.

The serial port of the device has been designed to operate in industrial environment where a number of pulse and electric disturbances are present. To protect the input stages, these are fitted with disturbance suppression circuits, whereas the output stages provide signals ensuring nearly disturbance free level.

For the application of the welding control devices in the WMSNet, PROFIBUS FMS or ETHERNET TCP/IP centralising network, refer to the relevant specifications.

While implementing the line, a few practical requirements are to be observed by the user.

- Avoid long common paths of line cables with power cables. Do not forget this warning specially when planning the lines and the network.
- Limit the network cable length to the minimum required. (Respect the RS485, PROFIBUS or ETHERNET requirements for length).

In addition, the best results are achieved if the following is taken into consideration:

- Terminate the line as specified in the installation manual of the network card.
- Connect all controls with the network interface card (daisy connection) so to have only one line of transmission.
- The cable is to comply with the relevant RS485, Profibus or Ethernet specifications.

WHITE PAGE

2. Characteristics and general description of the Weld334m

2.1 General description

The Weld334m is a control device intended for single-phase AC powered, resistance welding machines. It is capable of managing all the operations run by the machine it is associated with; the Weld334m also provides adequate diagnostics for the plant and welding process and carries out welding current regulation by chopping the voltage applied to the power transformer.

The Weld334m can be field programmed via the HHT4300 graphic unit or, through the centralising network, via a remote computer equipped with the WMS software and the adequate communication card.

It permits running up to a maximum of 255 welding programs and 16 different self-increment programs (stepper). The internally mounted clock provides the correct absolute timing reference; this function is also available for the stand-alone utilisation, meaning with independent control.

The HHT4300 programming unit is removable, thereby preventing any interference of unauthorised personnel on the welding programs.

The operating frequency of the unit is 50Hz or 60Hz.

Facility is also provided to memorise and transfer data and programs through a commercially available PCMCIA type memory card.

The welding control interfaces with a number of equipment and actuators, e.g. welding solenoid valves, process controllers (PLC) and robots, by connecting with the field or with standard wiring or through a serial line (optic fiber) in conformity with the Profil-C0 protocol of Interbus-S standard.

2.2 Block diagram of 334m

The 334m can be divided into two separate functional blocks.

The first block is the basic part of the system and consists of the main cards, which must always be installed, two internal fixed cards (power feeder and BUS) and three removable ones (CPU, I/OB and ADC).

The second functional block consists of the additional configuration card pack: I/O Expansion, Memory Card/Printer, EVS Proportional, Network.

Through these cards, the control device can:

- Be configured for advanced or special applications which are used in the resistance welding field
- Be upgraded with optional functions such as proportional solenoid valves or o memory card
- Manage a serial communication port to the welding central unit

The block diagram is shown below.

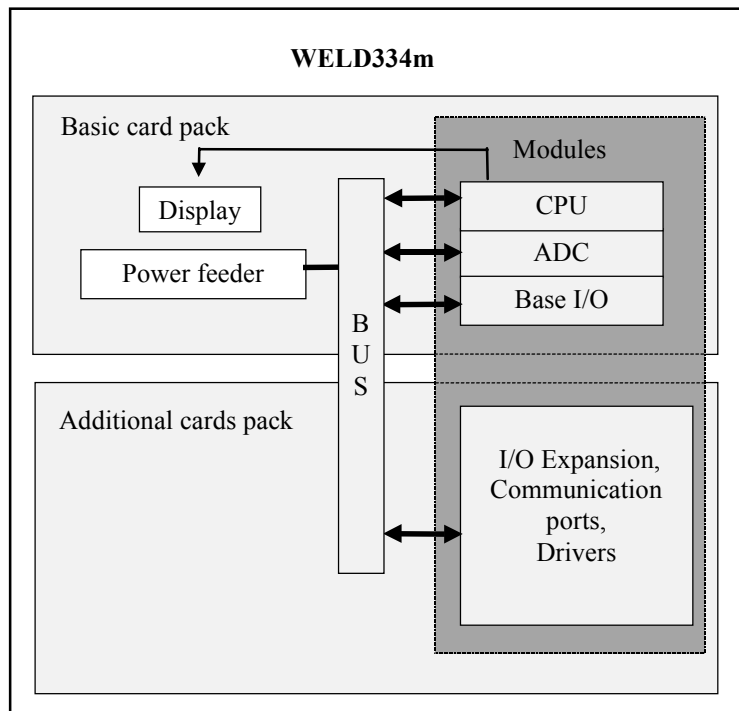

2.3 Hardware configuration

Every function has been housed on a dedicated card; in addition to this, 24Vdc discrete inputs and outputs are divided into Base and Expansion types.

The first position on the BUS, near connectors P1 and JP1, is to be compulsorily dedicated to the card CPU.

List of available cards:

Order code	Type	Card description	Card name	Card order code
		Power supply	F370 PSM	33037000
		BUS - interconnection card	F351 BUS	33035100
		4-digit Display	F363 DPY	33036300
		CPU	F384 CPU	33038400
		Analogue card	F353 ADC	33035300
		Proportional servovalve module	F364 SEV	33036400
		Basic I/O Terminal	F360 IOB	33036000
		Expansion I/O Terminal	F356 IOE	33035600
		Interbus-S optical OPC	F376-OPC	33037600
		Memory card + Printer	F359-MCP	33035900
		Ethernet card with Data Key	F381-ETH	33038100
		CAN Ethernet 10/100 Mbit with Data Key	F386-ETH	33038600

 alternative

2.4 Characteristics

Control power supply:	Alternated current: min. 14,4Vac rms max.32,4Vac rms Direct current ⁴ : min.18Vdc ² max.36Vdc Protection: self-reset type ³	Voltages recommended: 27Vac +10/-15% ¹ 24Vdc +20/-15% ¹
24Vdc I/O total power:	24V internal: ±10% 1,5A max 24V External: -15%+20% 1,5A max 24V Interbus-S: -15%+10% Protection: self-reset type ³	
discrete digital I/O:	Inputs:	Voltage: 18-30Vdc Protections: Overvoltage (disturbances and peaks)
	Outputs:	Voltage: 24Vdc max 0,3A EV, EVS: 24Vdc max 0,3A Pulse Ctrl. : 24Vdc with 10 ohm 2W resistance in series for current limitation Protections: Short circuit Overcurrent Overvoltage (disturbances and peaks)
Programming port:	local: Serial type for GF WELDING HHT4300 unit or Laptop PC (with WMS GF WELDING software) On line: Serial, via the WMS GF WELDING centralising system (see optional)	
Current sensor input (TA): Analogue voltage input (TV): Analogue voltage input (TFE): External sync.: System program: No. Of Programs: Welding channels: Storage:	type 150mV/kA (adjustable) ±36V max ±36V max 12-33Vac On flash-eprom; it can be updated through the memory card 255 2 The storage and the internal clock are powered through a lithium battery with a surveying circuit of the battery charging status and Supercap for data holding when replacing the battery. The battery life depends on the operating conditions.	
Optional extras: Serial Card: Printer port: Port for external memory card: Proportional solenoid valve module:	Ethernet Tcp/Ip for WMS GF WELDING centralisation network Parallel, standard PCMCIA memory card 0-10V Voltage (with protection against short circuit) 4-20 mA current	

Notes:

1. IEC 1131-2 Standard
2. The value does not include the voltage ripple
3. See characteristics at paragraph 3.3
4. The external synchronism is to be used, see paragraph 3.4

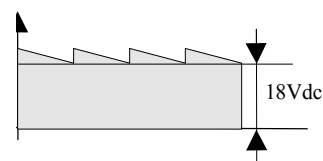

2.4.1 Utilisation characteristics

The construction complies with the EC requirements, CE marking

Operating temperature: 0° to +60°C, humidity 0 to 80% without condensation

Storage temperature: -40 to +80°, humidity 0 to 90% without condensation

Weight: 2,5Kg maximum (depending on the configurations)

2.4.2 Dimensions, overall dimensions and fastening positions.

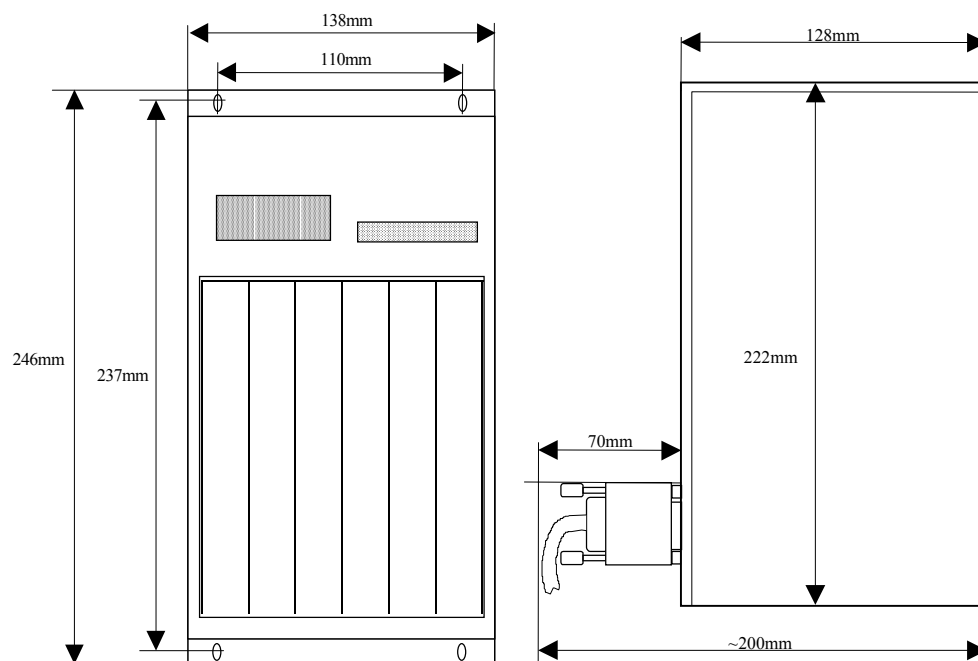

2.4.3 HHT4300 programming unit

The unit connects to the P1 connector of the control device and communicates through an RS485 Full duplex serial port.

It consists of a rectangular-shaped, 240x64 dot LCD display (8 lines – 40 characters consisting of 6x8 dots).

Touch sensitive keyboard with integral surface (bubble).

Keys layout: 4 arrows, enter (ENT), quit (ESC), +, -, 5 function keys.

Remote connection distance:

- With direct connection: 100m
- With indirect connection (separate power feeder): 600m

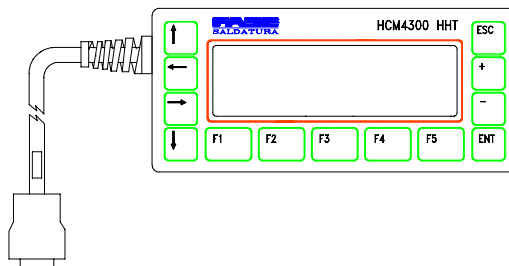

Dimensions: L=200mm, H=90mm, Pr=35mm
 Operating temperature: 0° to +45°C with humidity from 0 to 80% without condensation
 Storage temperature: -40 to +80° with humidity from 0 to 90% without condensation
 Weight : ~500g

9-way, Sub-d socket connector

Pin	Signal	Description
1/6	0VH	Earth
2/7	+VH	HHT4300 programming unit power supply
3	N.C.	Polarising pin
4	RXD+	Data reception +
5	TXD+	Data transfer +
8	RXD-	Data reception -
9	TXD-	Data transfer -

2.4.4 Connection through Laptop

The Laptop connects to the P1 connector of the control device and communicates through an RS485 Full duplex serial port, with WMS rel. 2.61 and upgrades.

Cable for connection between Weld334m and PC laptop: F2118;
 Order code: 32102110;
 With converter RS485 / RS232;
 L=2,5mt.

3. Power supply and 24V for I/O

3.1 Control device power supply

The power supply section resides on the PS 8way, 5.08mm pitch connector for disconnectable terminals which are located on the front. Also housed on this connector is the input for the external synchronism.

Either incoming direct current or alternated current is accepted by the control device (see characteristics at paragraph 2.4).

The control device earthing is to be carried out by means of the faston terminal located at the side of PS connector.

3.1.1 PS . Description of signals

8-way, 5.08mm pitch PS connector for disconnectable terminals

Pin	Signal	Description
1-2	PWR/RTN	<p>Main power supply of the control device.</p> <p>The device can be powered from either d.c. mains – from 18 to 36Vdc – and a.c. mains – from 14,4 to 32,4Vac – with no need for the user to change the connections or the internal settings.</p> <p>If powered from a d.c. source, the pin polarity is irrespective of this status.</p> <p>NOTE: if the unit is fed from a d.c. supply, the external synchronism must be used.</p>
3-4	SYNC +/-	<p>External synch signal.</p> <p>Sensitivity: 12-33Vac.</p> <p>It permits the synchronisation with power supply on the power side (SCR), through an insulation transformer connected to the same phase.</p> <p>This must be used when the unit is powered from a line separate than that of the welding machine or when it is powered from the d.c. mains.</p> <p>If used, this signal must be configured on the power feeder card through 2 jumpers (see paragraph 3.4).</p>
5	24VI	<p>+24Vdc output, internal.</p> <p>It is used when one wants to use +24V supply internal to the device for powering the I/O.</p> <p>It can be cut out for enabling 24V from a remote unit (Robot).</p> <p>For the connection, refer to paragraph 3.2.2 figure (b).</p>
6	24VE	<p>24Vdc external input for discrete, digital I/O.</p> <p>Max. Load 1,5A.</p> <p>For the connection, refer to paragraph 3.2.2 figures (c) and (d).</p>
7	0V	<p>Input for 0V external common for logic I/O.</p> <p>For the connection, refer to paragraph 3.2.2 figures (c) and (d).</p>
8		<p>Contact available for Earth connection.</p> <p>For the connection, refer to paragraph 3.2.2</p>

3.1.2 Connections for main power supply.

Diagrams for control device power supply are illustrated below.

- Ac input taken from the power line of the welding transformer.

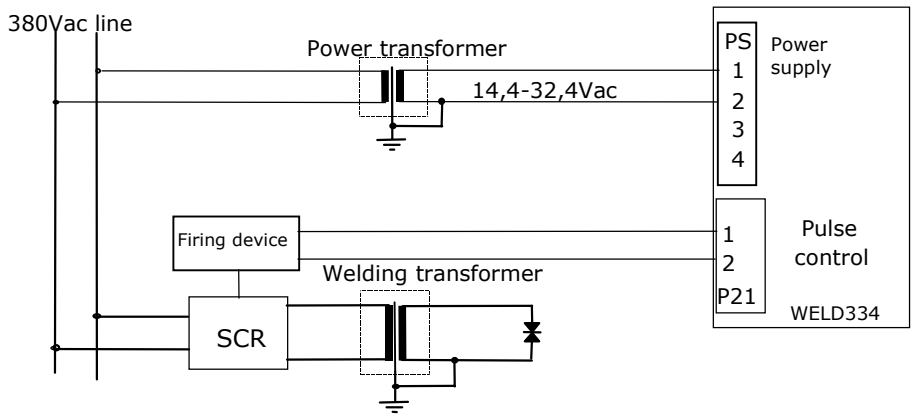

- Dc supply

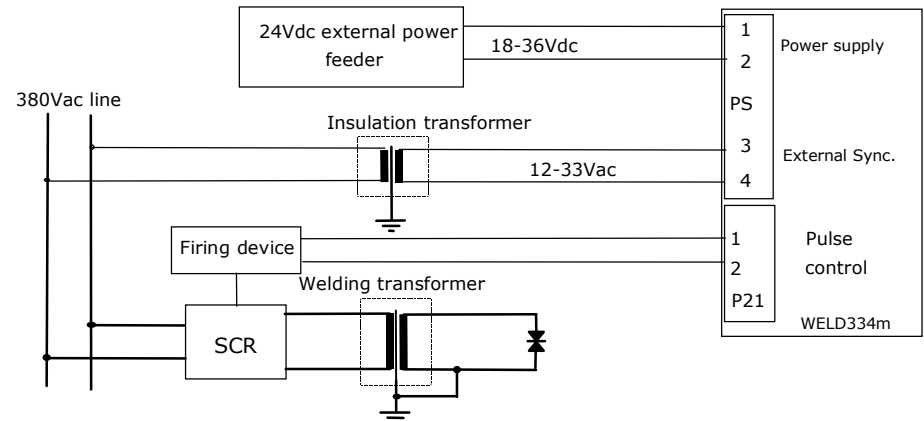

- Ac supply taken from a line separate from the welding transformer power supply.

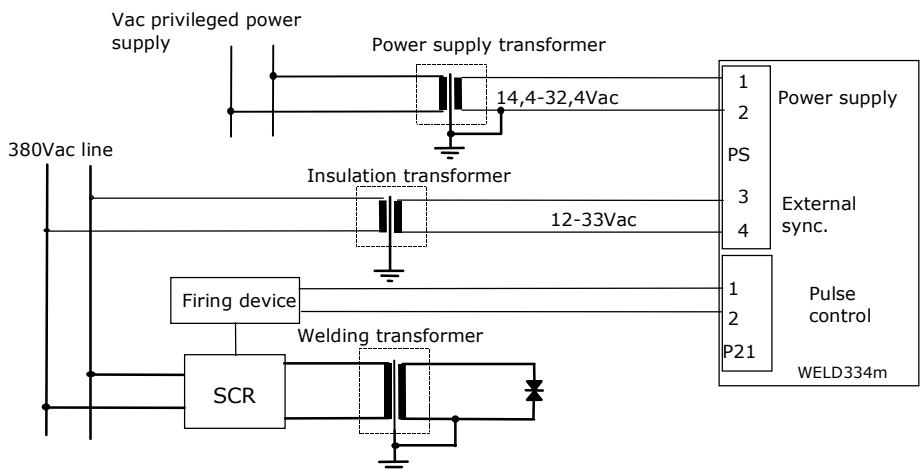

3.1.3 Power consumption

Power used is dependent on the type of application carried out on the machine.

Table below lists the minimum power to apply to the control device in its full configuration, depending on the type of power supply being used.

Power feeder	Power supply type	Consumption	
		24V Internal	24V External
F350/370	Vac Transformer (recommended):	110VA	62VA
F350/370	Vdc Power feeder (recommended):	80W	45W

3.2 Use of 24V - I/O

To make use of 24V supply of I/O, certain rules are to be observed. These rules depend on the type of application used on the machine.

The Weld334m is supplied by GF WELDING in a standard configuration; 24V = make jumpers between pin 5 and pin 6 (see figure below).

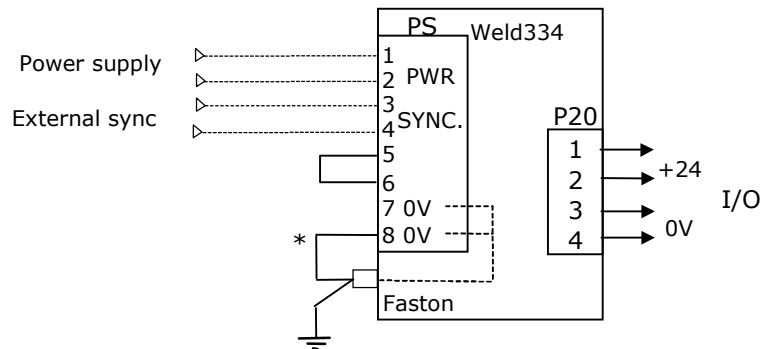

3.2.1 Selecting 24V – internal or external

24V supply for I/O input is distributed in such a way to have two internal separate lines. These lines are alternate between one another:

- One line for external 24V (24VE), whose input is located on pin 6 and pin 7 of PS
- One for internal 24V (24VI) which, from the power feeder, is connected directly to bus connectors JP2/3/4/5/6 (see figure 1).

Figure 1

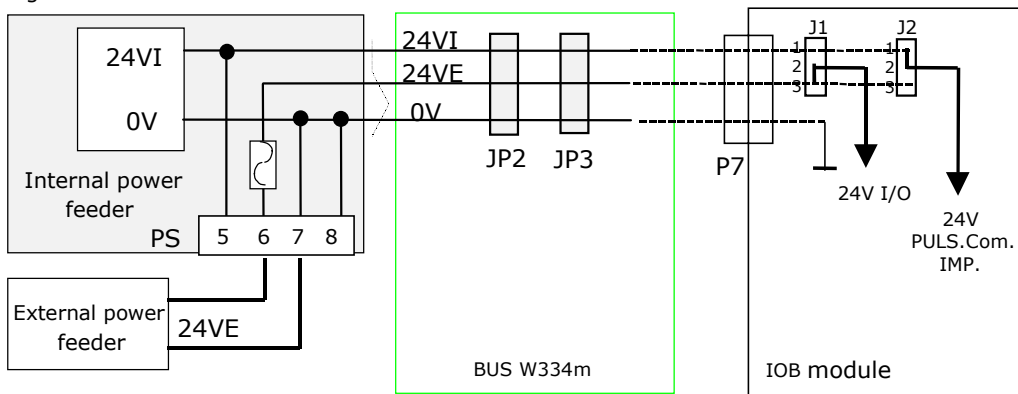

The modules using 24Vdc supply have 2 jumpers: J1 for 24V of I/O and J2 for 24V supply used for the pulse control or the servovalve. These jumpers allow +24V supply to be set toward the internal power feeder or toward an external+24V supply.

Each module is factory-calibrated (standard calibration) and calibration value is shown on the layout page in the chapter concerning each module.

Figure 1 gives an example of setting for these 2 jumpers.

24V I/O can be managed in the following ways:

- ◇ **Direct:** 24VI supply with pins 5 - 6 of PS being free (see paragraph 3.2.2 figure a) J1 connector: jumpers of I/O and ADC cards to be made in position 1-2.
- ◇ **Indirect :** 24VI supply with pins 5 and 6 of the PS: make jumpers or cut them out from a contact (see paragraph 3.2.2 figure b).
24VI supply, which in this way can be cut out from the outside (enabled/disabled), is re-closed on 24VE line.
- ◇ **External:** with external 24V supply connected to pin 6 and pin 7 of the PS (see paragraph 3.2.2 figures c and d).

Summary Table of 24V I/O jumpers of cards

24V Selection	J1	J2*
Internal	1-2	1-2
Internal indirect	2-3	1-2
External	2-3	2-3

* Where present

3.2.2 24V connections for discrete I/O

Figure a: Use of +24VI supply in direct way

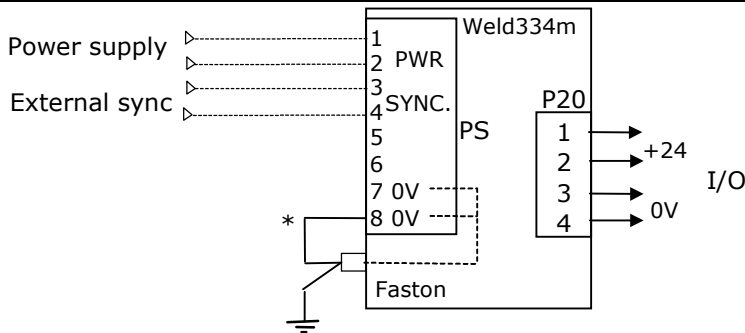
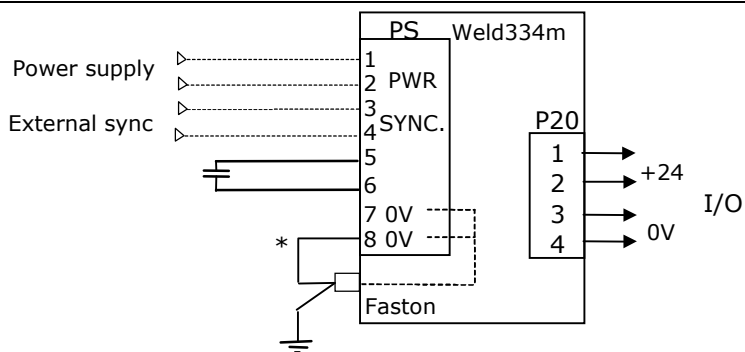
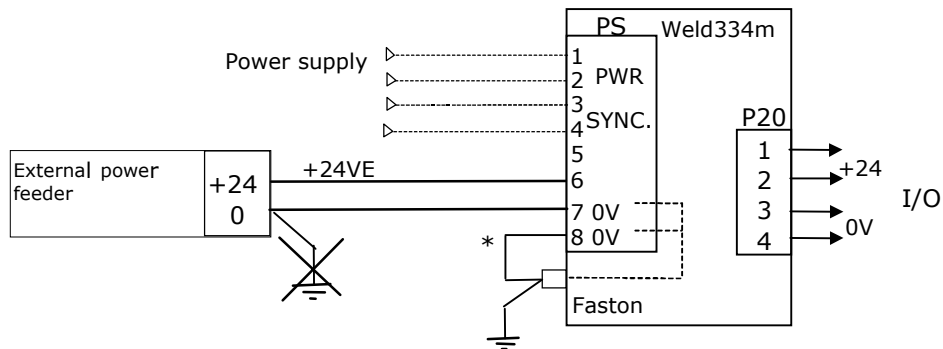

Figure b: Use of +24VI in indirect way



24VI is cut off on the PS between pin 5 and pin 6. Thus, 24V supply of I/Os can be enabled and disabled independently of the control device.

Figure c: Use of +24VE (external) with earth on the Weld334m side



If earthing for 24VE supply has been performed on the welding control device side, then the external power feeder is not to be earthed.

Figure d: +24VE with earth on the external power feeder side

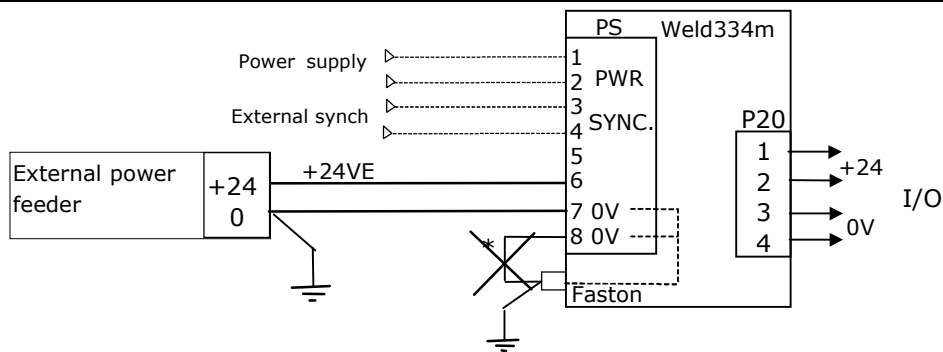

If earthing for 24VE supply has been performed on the external power feeder side, then the welding control device is not to be earthed.

- * The connection of pin 8 of the PS to the earth faston terminal is required only if the internal power feeder is of F350 type, if the internal power feeder is of F370 type, the link to the earth faston terminal is done internally and the connection between pin 8 of the PS and the faston terminal is not required.

3.3 General protective devices on power supply

General schematic of protective devices.

Protection A:

Voltage/current limit circuit placed on the power feeder primary

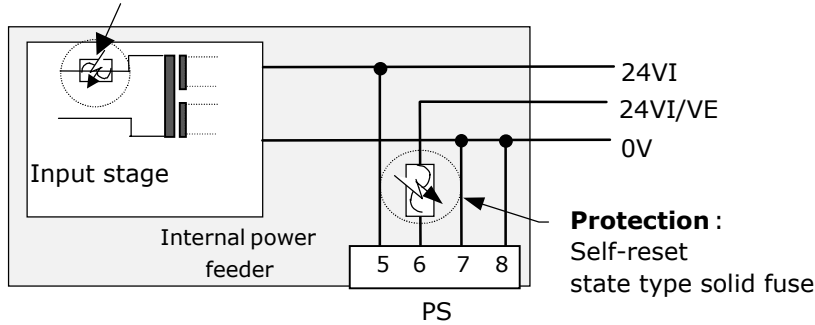

On the basis of the type of connection in use, the protections operate in the following way:

◇ **Protection A:** General overvoltage and overcurrent protective circuit .

This protective device trips in the following cases:

1. If, when switching on the device, the line voltage exceeds the hazard limit of rated ranges.
2. In all cases of internal short circuit, on the output of the pulse control or of 24V signal of the servovalve.
3. In case of overcurrent, if 24VI for I/O points is used both in the direct connection mode (see paragraph 3.2.2 figure **a**) and in the indirect one (see paragraph 3.2.2 figure **b**).

With this type of connection, the protective device **A**, which features a faster switching time, prevails on the device **B**.

In order to reset the functional conditions, it is necessary to cut off power and remove the cause of the short, then switch on the device again after about 30".

If by activating it again, the device does not switch On (**RUN** led indicator of CPU Off), then check that line voltage is correct and that it complies with the characteristics indicated (if not, the control device will stay off due to the protection device).

If all these conditions are observed but the device does not switch On, the power feeder is likely to be damaged. Replace it.

◇ **Protection B:** current limit circuit on the external 24V supply.

It intervenes in case of use of the external 24V supply for the I/O points (see paragraph 3.2.2 figure **c**).

Once the cause has been removed, the protection resets automatically.

Characteristics of current limitation as a function of temperature*.

Power feeder type F350-PSM

	Temperature* (°C)			
	20°	40°	50°	60°
Current (A)	3.75	3.04	2.70	2.36

Power feeder type F370-PSM

	Temperature* (°C)			
	20°	40°	50°	60°
Current (A)	2.5	2.03	1.8	1.58

* Characteristics refer to the operating temperature of the component itself.

3.4 Setting the external synchronism

For the firing pulse to the SCRs to be synchronised with the mains of the SCRs, the two jumpers for the line synchronism must be set on the card.

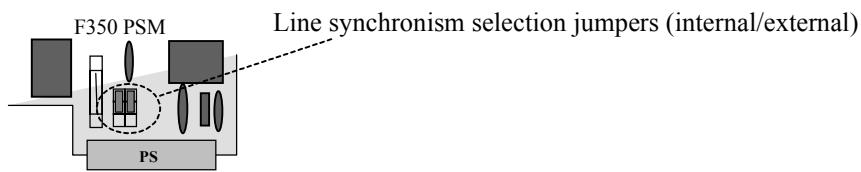

1. When the control device is powered from the a.c. mains taken directly from the power line of the SCRs, jumpers are to be set to PWR-RTN, (standard configuration).
2. If the synchronism signal is to be taken directly from the power group through an attenuation/insulation transformer, the jumpers are to be set on S1-S2. This configuration is compulsory when the device is powered from the d.c. mains.

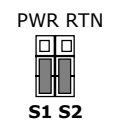
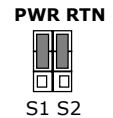

NOTE: The secondary of the insulation transformer is not to be earthed

Example of connection for the external synchronism

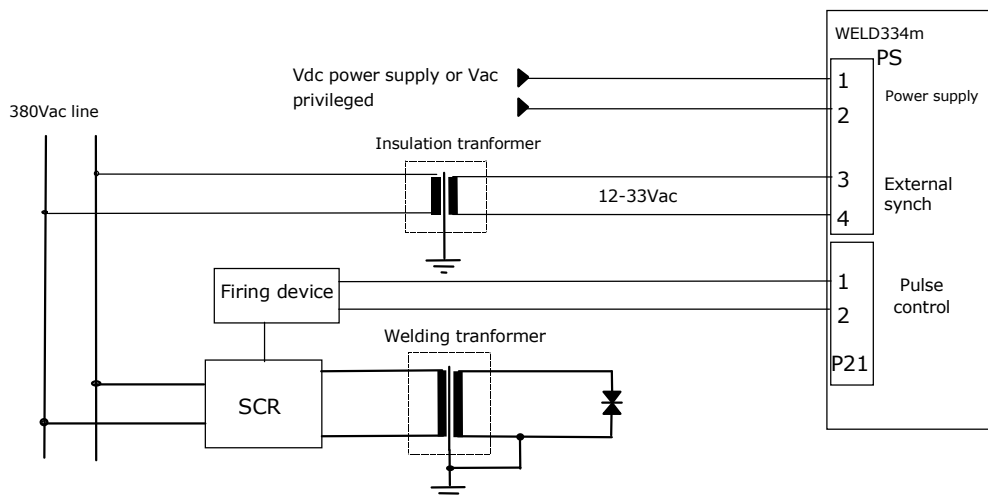

WHITE PAGE

4. F351-BUS Interconnection card

BUS interconnection card for signals and power supply.
J2 connector takes 24V supply for the I/O power supply.
J1 connector takes 5V supply for the cards and +V for programming unit HHT.
JP1 connector is used to power the programming keycard (via CPU).
The connectors JP2, 3, 4, 5, 6 distribute 24VI and 24VE supply for the I/O points.
Connectors P1...6 form the digital BUS.

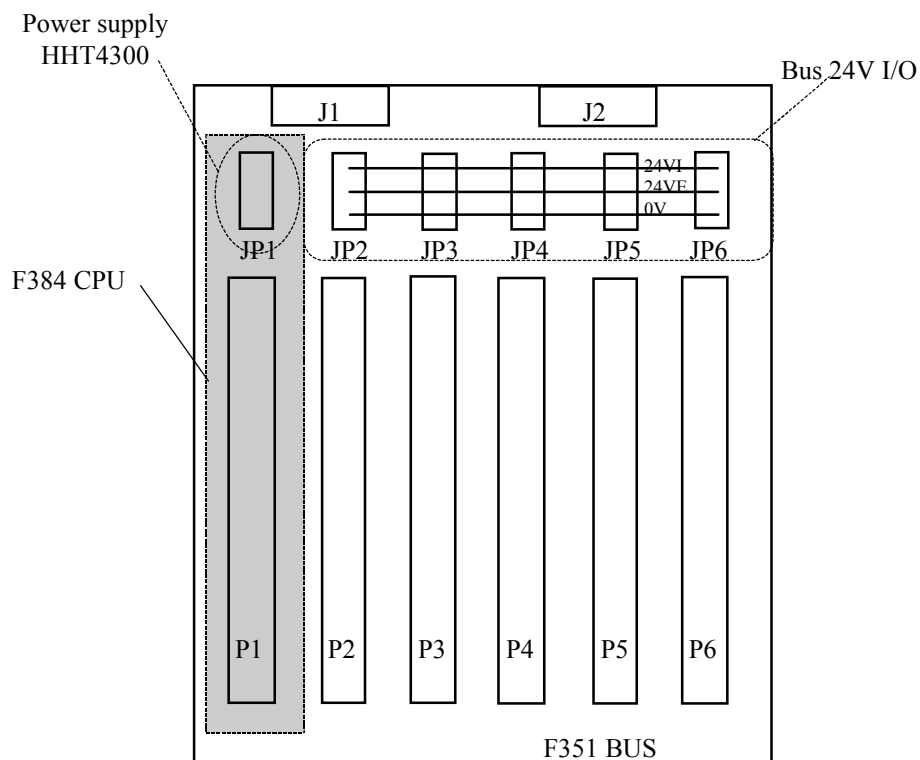

The position JP1-P1 is typical for the CPU card, all the remaining positions are available for the control device configuration.
The BUS module needs no preset.

WHITE PAGE

5. F384-CPU Microprocessor card

This is the system calculation centre and it is fitted with a MCU Motorola 68332 card (20MHz clock). Data and program RAM resides on flash eeprom (1MB).

Permanent data is stored in a buffer battery.

The CPU has 2 ports, an RS485 full/duplex port for the HHT4300 programming terminal or a Laptop (P1 Sub-d 9-way connector located on the front part), and another one for connecting the multifunctional display (internal port).

CPU status Led indicators:

- LOWBATT** - Red: illuminated during power reset (when switching on the Control device) and when the reset is given via the push button.
If it stays On during the operation (RUN led indicator illuminated) this indicates that the battery is nearly down.
- RUN** - Green: the processor is operating correctly when illuminated.
This indicator is OFF during the reset or when the Watchdog (indication of Fault) condition intervenes.

Reset push button

The Reset push button is placed in the lower part, This control has direct influence on the 68332 and is used (in case of system shutdown) to re-start the program with no need to cut off power to the control device. The Reset control is not an alarm reset and it must not be used to this end.

Internal battery for data backup

Lithium battery with surveying circuit of the charge status and Supercap (high capacity capacitor) used to store data during the replacement. The battery is housed in a container which facilitates the replacement.

To replace the battery, refer to Appendix A - Maintenance

Average battery life

<i>Extinction</i>	<i>Operating condition</i>	<i>Duration (years)</i>
Daily	6 working days	3
Weekly	5 working days	4
Weekly	6 working days	5,4

P1 - 9-way, Sub-d socket connector

RS485 serial communication port for the connection to the HHT4300 programming unit or to a PC

Pin	Signal	Description
1/6	0VH	Earth
2/7	+VH	HHT4300 unit power supply
3	N.C.	Pin bias
4	RXD+	Data reception +
5	TXD+	Data transmission +
8	RXD-	Data reception -
9	TXD-	Data transmission -

Maximum length of connection cable: 100m

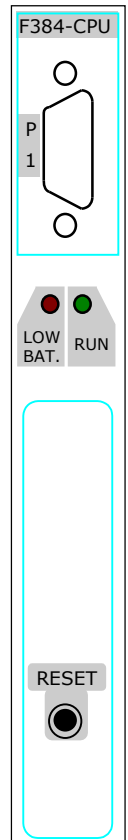

Card layout: Standard setting of jumpers.

- JP4-5-8-9: (Off)
- JP3: 3-4, 6-7
- JP6: On

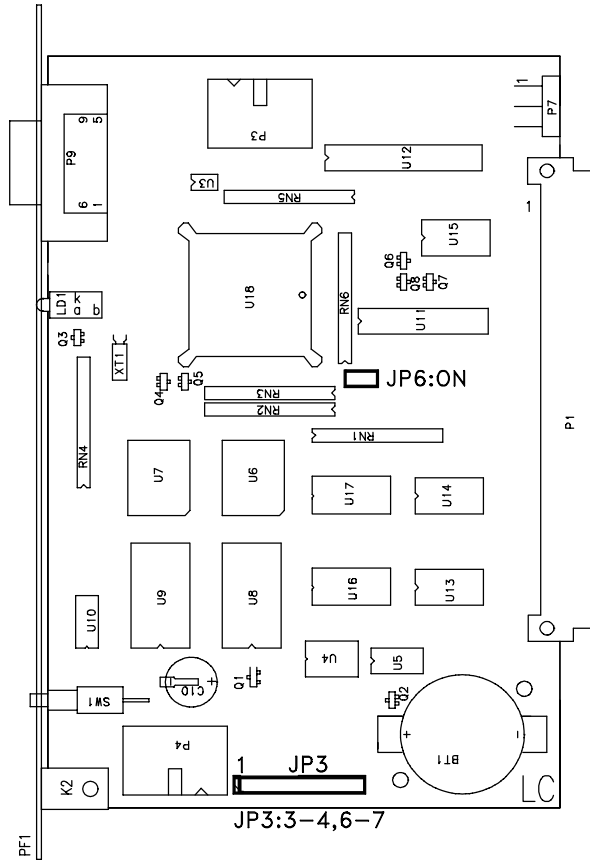

6. F353-ADC Analogue Card

This card includes 3 analogue inputs for acquiring signals from connectors P2 - P3 - P4 and the internal arrangement for housing the SEV module (optional extra) with output on the P2 for the electrode pressure adjustment (proportional solenoid valve).

6.1 P3 e P4 . Description of the analogue inputs

P3 - TV - 9-way, Sub-d plug connector

Input for acquiring analogue signals (optional extra); Generally it is not used and is reserved for special applications
Sensitivity: 36V max.

Pin	Signal	Description
7	TV+	Positive signal
8	TV -	Negative signal
9	TVsch	Cable screening

P4 - TA - 9-way, Sub-d plug connector

Input for acquiring analogue signals.

It is used for connecting the current sensor.

The acquisition of this signal (when welding current is constant), permits the real-time check on the current trend during the welding pulse.

Input is so arranged to accept a 150mV/kA $\pm 3\%$ Rowgowsky type sensor with 20-25ohm internal resistance.

Sensitivity: adjustable.

Facility to connect up to a maximum of 6 sensors in series.

For correct use, see setting parameters indicated in the programming manual.

For the connections, refer to relevant application diagrams.

Pin	Signal	Description
1	TAsch	Cable screening
4	TA+	Positive signal
5	TA-	Negative signal

NOTE: The control device can be operated even if the F353-ADC card is not installed, but, in this case, only the «normal» welding mode is allowed.

This type of operation however is detrimental to the processing quality and it has now been superseded.



6.2 P2 . Description of the signals for the Solenoid valve and the TFE

The two green LED indicators are for the proportional solenoid valve and their function is the following:

ENSERV : = illuminated when the relevant output on P2 is active

STSERV : = illuminated when the signal is present on the input.

15-way, Sub-d socket connector

Pin	Signal	Description
1	TFEsch	Screening of analogue voltage input
2	TFE-	Analogue voltage input
3	VServ-	0V voltage output for solenoid valve
4	IServ+	4-20mA current output for solenoid valve
5	Res2	Reserved
6	STSERV	Servo valve status input
7	0V	Solenoid valve power supply
8	24SV	Solenoid valve power supply
9	TFE+	Analogue voltage input
10	VServ+	0-10V voltage output for solenoid valve
11	Schild	Screening for ISERV or VSERV signal
12	IServ-	0V current output for solenoid valve
14	Res1	Reserved
15	ENSERV	Solenoid valve Enable Output

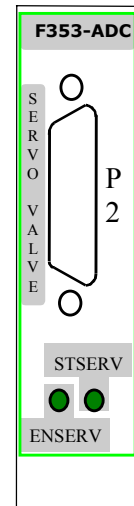

P2 . Functional description of signals

Pin	Signal	Function
1,2,9	TFE	Analogue voltage acquisition channel. This input can be used for receiving the indication of the electrodes force through a dedicated transducer.
4,12	ISERV	Current output. Operating range from 4 to 20 mA. Signal for piloting a current type solenoid valve. The valve adjusts pressure on the electrodes as a function of this signal, 20mA correspond to 100% of the pressure value which has been calibrated on the proportional valve. Load resistor:470 Ω (range: from 200 to 600 Ω)
3,10	VSERV	Voltage output. Operating range from 0 to 10V. Signal for piloting a voltage type solenoid valve. The valve adjusts pressure on the electrodes as a function of this signal, 10V correspond to 100% of the pressure value calibrated on the proportional valve. The output is protected against overcurrent and short circuit. In case of tripping of the protective device, outgoing voltage falls to 0 Volt. Typical resistive load: 10K Ω
6	STSERV	Input. Electrodes pressure OK. The logic condition 0V or 24V can be defined in the Setup stage. Before welding, the control device waits for this signal produced by the solenoid valve: if the logic condition is TRUE (24V), the control device gives the welding pulse, if it is FALSE (0V), the welding sequence stays idle with the electrodes closed.
7	0V	0V solenoid valve power supply.
8	24SV	Solenoid valve power supply Power supply to the solenoid valve is monitored with a voltage value: if it falls below 22.5V (5% of 24V), the ENSERV enable signal of the solenoid valve is not activated.

P2 . Functional description of signals

Pin	Signal	Function
11	Shield	ISERV o VSERV servovalve signal screening
15	ENSERV	Output. Active at 24V. Proportional solenoid valve enable. Before commencing the adjustment operation, the solenoid valve waits for this signal from the control device. ENSERV output is deactivated when: <ul style="list-style-type: none"> • Solenoid valve power supply falls below 5% • I/O sequence is during cold processing cycles • CPU is in the reset status.

Card layout: standard setting of jumpers

J2: 1-2
Jp5: Off

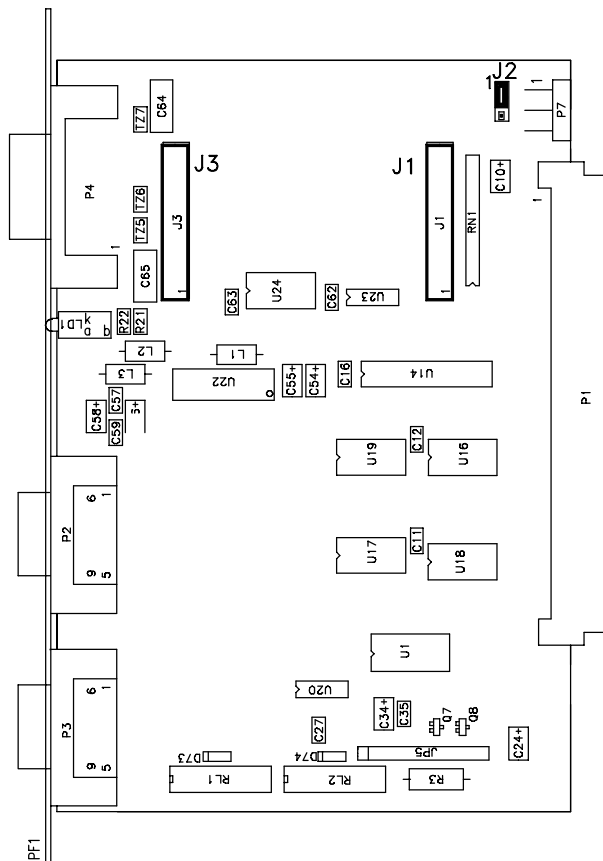

WHITE PAGE

7. F364-SEV and F385-SEV: Proportional Servo Valve Modules

The F364-SEV or F385-SEV module (housed internally on the F353-ADC card) is an analogue driver with two outputs: a voltage output and a current output used to pilot a proportional servo valve.

The proportional servo valve is able to adjust the pressure inside a pneumatic circuit automatically on the basis of an analogue voltage or current signal from the welding control device. The welding gun pneumatic cylinder converts the pressure in the pneumatic circuit into an electrode closing force.

This function is of great importance for process quality. The electrode closing force, the time during which current flows and the welding current are the three main parameters that determine welding quality.

With the proportional servo valve the electrode closing force can be kept under control.

For use and programming of the proportional output, please see the Control Device Programming Manual.

7.1 Servo Valve Adjust:

The pressure servo valve must be adjusted for two operating conditions: the first is the line pressure under machine stopped conditions; the latter refers to the working pressure of the cylinder.

These adjustments are dependent on the settings entered in the Setup menu and in the welding program (see Programming Manual).

On the basis of these settings, the Weld334m pilots the analogue voltage output over a range from 0 to 10V or the analogue current output over a range from 4 to 20 mA.

The control can enable/disable the servo valve by means of the signal ENSERV.

After a welding sequence has been selected, the control pilots the analogue output on the basis of the parameters P1 and P2 set in the welding programme. The guns close and the electrodes reach the requested closing force.

Before carrying out the welding operation, the control device waits for the STSERV signal from the servo valve, which confirms that the rated pressure has been attained. It then imparts the welding pulse.

If the STSERV signal fails, the cycle stops under pressure and welding is not done.

If the servo valve is used with the current analogue output 4 – 20 mA, the continuity control can be enabled on the output circuit, so if connection with the servo valve is interrupted the welding cycle is also interrupted. (present from F364-D version onwards)

If the servo valve is not used, the «**PRESSURE-OK Input mode**» parameter in the Setup menu is set to zero.

For the connections, see application diagrams

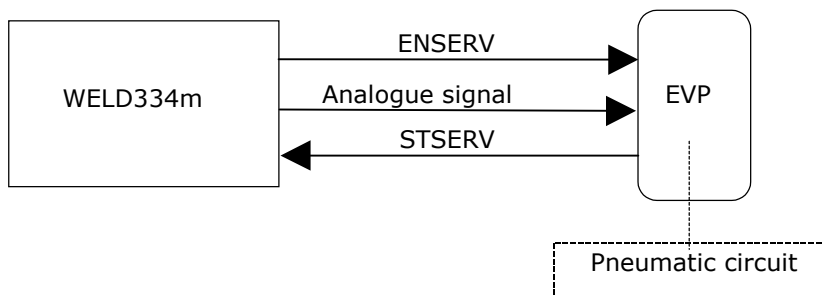

7.1.1 Voltage outlet characteristics

Range: 0-10V

Single-ended type, with VSERV- pin connected with the 0V of the +24SV

Minimum load: 2k ohm

Typical load: 10k ohm

Converter resolution: 12 bit

Converter accuracy: ± 3 lsb

Protection against permanent short-circuits

Protection of VSERV+ outlet pin against accidental contacts up to 36V DC

7.1.2 Current outlet characteristics

Range: 4-20mA

Single-ended type, with ISERV- pin connected with the 0V of the +24SV

Maximum load: 600 ohm

Minimum load: 200 ohm

Converter resolution: 12 bit

Converter accuracy: ± 3 lsb

Protection against permanent short-circuits

Protection of ISERV+ outlet pin against accidental contacts up to 36V DC

Test on open current loop

7.2 Connection of the F364 / F385-SEV module on the F353-ADC card

The F364 / F385-SEV module houses the whole electronic circuit for the servo valve management.

Its mounting on the F353-ADC card poses no problems, this can be easily made through the two connectors J1 and J3.

The J3 connector is polarised (contacts 9 and 10 are not present) to prevent incorrect mounting of the module.

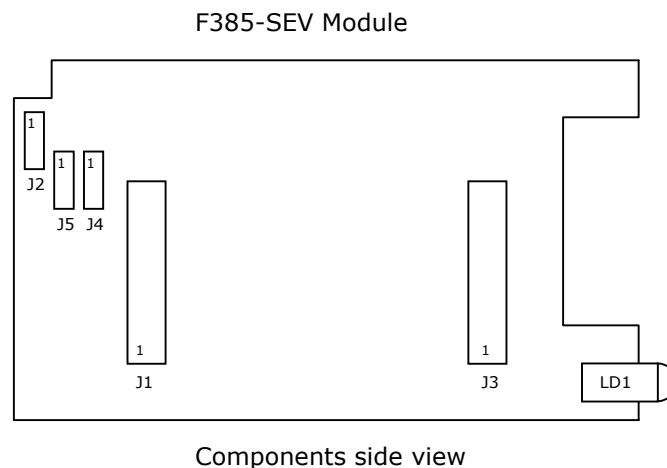

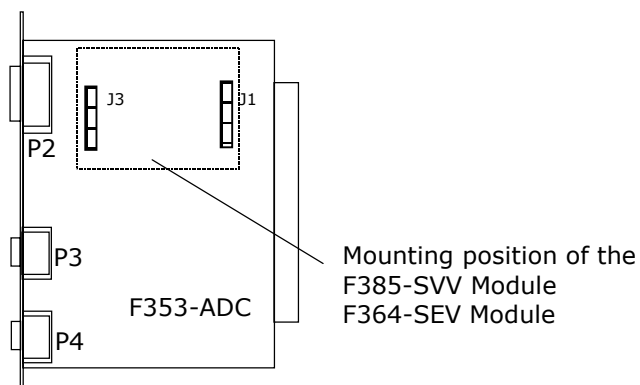

Fixing of the module is ensured by the tight fit of the two connectors J1-J3

Make sure that the module is properly fitted into the card.

(For the SEV pin-out refer to the chapter "P2. Description of the signals for the Solenoid valve and the TFE").

7.2.1 Jumper function on connector J4

For further information consult the chapter "Use of 24V I/O"

Pins connected	Description
1-2	Power supply to SEV from internal 24Vdc
2-3	Power supply to SEV indirect from internal 24Vdc or from external 24Vdc

7.2.2 Jumper function on connector J5

Pins connected	Description
1-2 (Default)	24Vdc limiter SEV power supply OFF. Position required when stabilized 24Vdc is available (e.g.: with PSM type F370)
2-3 (Only for F364, for compatibility with old module F368)	24Vdc limiter SEV power supply ON. Position required when non-stabilized 24Vdc is available (e.g.: with PSM type F367)

WHITE PAGE

8. F359-MCP Memory Card and Printer

The F359-MCP card supports a PCMCIA type memory card (Ram Card) and the parallel port for connection to a printer.

MEMORY CARD

Standard connector for the PCMCIA card.

The memory card allows saving the configuration as well as all the welding programs of a control device or memorising the operating software.

Thus, you are given the facility to perform two maintenance operations quickly and in an easy way.

The first operation concerns the immediate replacement of a welding control device.

Thanks to the Ram Card all data is quickly transferred from one device to another with no need to configure and hand copy all the programs to the new control device.

The second operation is the operating software update through by a simple loading operation. In addition, the operating system can be transferred from one control device to another.

For the correct use of the Ram Card, please consult the Programming Manual, chapter MEMORY CARD.

P5 - PRINTER

25-way Sub-d socket connector

The parallel port allows the connection to a (parallel) printer for printing data concerning the programs, steppers, reports, etc...

For this function, please consult the W334m Programming Manual.

To connect the printer, a standard cable for printers is sufficient (Centronics type - 25-way parallel cable)

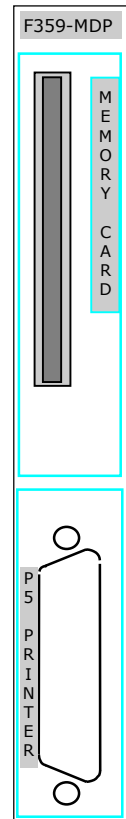

WARNING! This port is not compatible with serial printers

No setting jumpers are on the card.

WHITE PAGE

9. F360-IOB Card – Base I/O

This card is used for the basic connections toward the plant and houses a 2-position selector switch and the linear connectors P20, P21, P22.

9.1 Description of functions

Salda SI/NO (Weld YES/NO) Selector switch

It enables/disables the welding current.

The following components must also be enabled: Weld Yes/No selector switch in the Setup stage * and P30-14 input on the F356-IOE card.

Salda SI (Weld YES): Oriented to  = welding current enabled.

Salda NO (Weld NO): Oriented to  = welding current disabled

* See programming manual

9.2 P20 24Vdc - I/O

4-way 3.5mm pitch, linear connector with disconnectable terminal

Output of 24V power supply of devices external to the control device.

The source for 24V supply is dependent on the type of connection used on the PS connector of the power feeder (see technical section of power supply).

24V is protected against short circuit by the self-resetting fuse placed on the power feeder.

Beside pin 1 there is the green LED indicator which indicates the presence of 24V supply.

Pin	Signal	Description
1	24V	Output
2	24V	Output
3	0V	Gnd
4	0V	Gnd

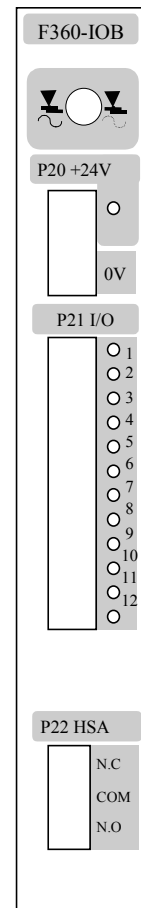

9.3 P22 - HSA – Circuit breaker trip

3-way, 5.08mm pitch, linear connector with disconnectable terminal

Relay contacts for activating the machine main switch tripping coil.

It is activated by the control device in case of serious fault occurring on the power section of the machine (e.g. SCRs in «out of welding» status) and by the activation of the Processor Watchdog signal.

Voltage on contacts: 48V 8A max.

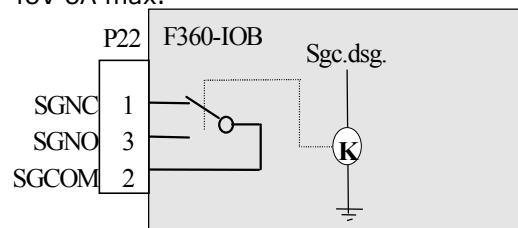

For connection, refer to the application diagrams

9.4 P21 . Description of signals

24V discrete digital inputs and outputs, protected against overvoltage.

Input sensitivity: 20/30V.

All I/Os are equipped with a LED indicator for the indication of the signal presence.

12-way, 3.5mm pitch, linear connector with disconnectable terminals

Pin	Signal	Description	Signal	Rating (I)
1,2*	COM.IMP.	SCR trigger control		2A
3**	TSCR	SCR temperature	Input	10mA
4	EMERG	Emergency stop	Input	10mA
5	Input	Free	Input	10mA
6	Input	Free	Input	10mA
7	Output	Free	Output	0,3A
8	Output	Free	Output	0,3A
9	FINESEQ	End of Sequence	Output	0,3A
10,11	RICHSALD	Request for welding	Output	Relay contact
12	CONSALD	Consent to welding	Input	10mA

* In the case of a Weld334m IMF integrated inverter, the function becomes: *Welding/starting time* with current 10mA

** In the case of a Weld334m IMF integrated inverter, the function becomes: *Inverter Ready*

P21 – Functional description of signals

Pin	Signal	Function
1	+24TRASF.	24V power supply to SCR trigger transformer primary (to be used for this purpose only).
2	COM.IMP.	SCR trigger Pulse control (See application diagrams).
3	TSCR	SCR over temperature OFF active. The sensor is to be of NC contact type. In the event of over-temperature, the TSCR signal is interrupted and the control device generates the relevant alarm and shuts down the machine cycle.
4	EMERG	EMERGENCY STOP OFF active. It is connected to 24V supply through an N.C. contact, which is broken (by robot or in manual mode), in case of emergency stop. The control device inhibits the sequence and hampers the start function as long as 24V is not reactivated on this input. See EMERGENCY STOP diagrams in Appendix B.
5	INPUT	24V discrete (min/max20/30V)
6	INPUT	24V discrete (min/max20/30V)
7	OUTPUT	24V, 0.3A discrete
8	OUTPUT	24V, 0.3A discrete

P21 – Functional description of signals

Pin	Signal	Function
9	FINE SEQ.	Output active at 24V. At the end of frequency cycles (electrode opening), the control device activates this output and terminates the sequence. If Repeat Function is enabled, the End of Sequence is not performed and the control device goes on starting from pressure cycles. (See diagrams relevant to cycle time on the programming manual)
10 11	RICHSALD+ RICHSALD-	Output. NO relay contact. At the end of the pressure cycles, the control device, ready to execute the welding pulse, activates the request for welding and waits for the consent (CONSALD - CONS. TO WELDING). It needs a common wire (contact 11) connected to 24V.

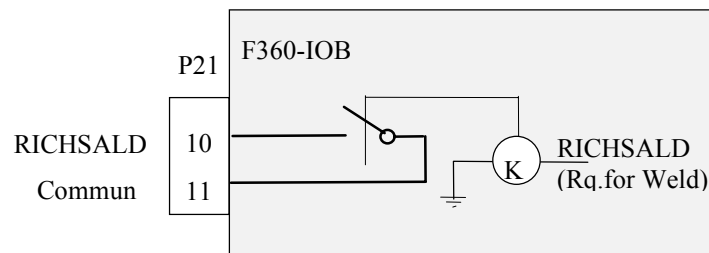

For the connection, refer to application diagrams

12	CONSALD	Consent to welding. Input active at 24V. The consent to welding is the enable signal for welding; it is an indication that the welding machine is ready. It is tested after the Request for Welding Signal has been activated. When not in use, this input is to be connected to 24V.
----	----------------	--

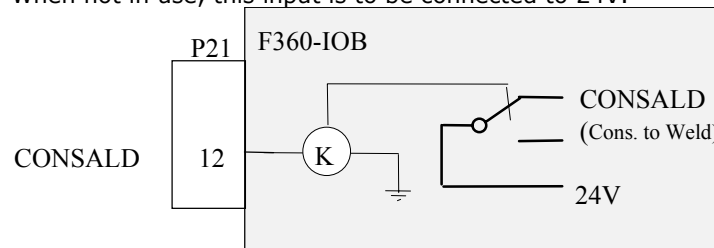

For the connection, refer to application diagrams

Card layout: jumpers setting

JP1: Off

J1: 2-3 – 24 Vdc External

J2: 1-2 – 24Vdc Internal

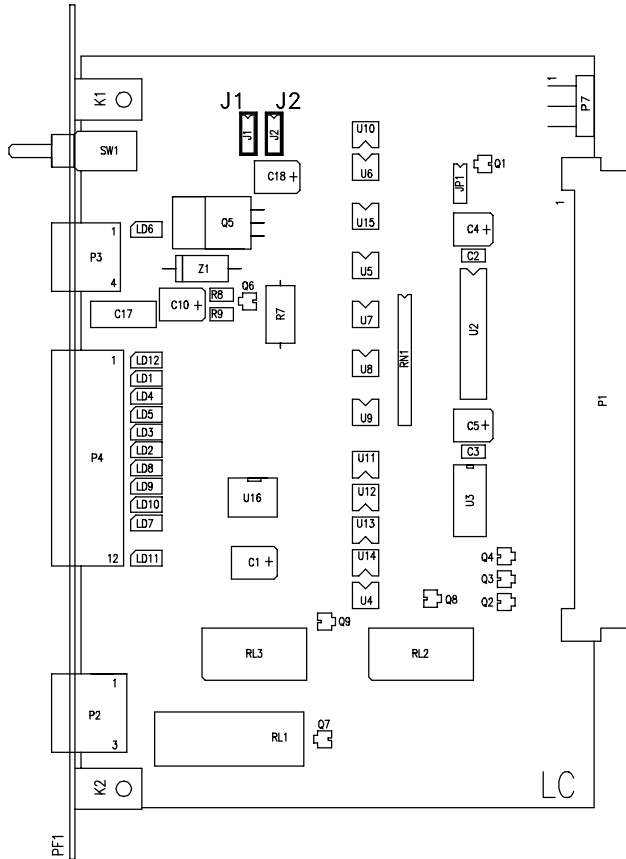

10. F356-IOE I/O Expansion Card

This card houses two terminal type connectors - a 18-way connector (P24) and a 16-way connector (P23) - for the connection to the field. They support 18 off 14V inputs (20/30V - 10mA) and 16 off 24V - 0.3A inputs, four of which (dedicated to the welding solenoid valves) are protected against the simultaneous clamping of guns through a relay interlocking.

All outputs are protected against short circuit.

10.1 P23 . Description of output signals

16-way, 3.5 mm pitch linear connector for disconnectable terminals

Pin	Signal	Description	Type
1	WALLSTA	Stepper A pre-alarm	Electrodes wear function
2	WALLSTB	Stepper B pre-alarm	Electrodes wear function
3	ALLSTA	Stepper A alarm	Electrodes wear function
4	ALLSTB	Stepper B alarm	Electrodes wear function
5	RICHRAV	Request for dressing	Electrodes wear function
6	RICHEL	Request for electrodes change	Electrodes wear function
7	ALARM1	Diagnostic alarm	Welding diagnostics
8	ALARM2	Hardware alarm	Machine fault
9	UNDCURR	Minimum current alarm	Welding diagnostics
10	OVRCURR	Maximum alarm current	Welding diagnostics
11	READY	Ready	Status
12	STATUS	Weld Yes/No	Status
13	EVSA	Channel A welding Solen. Valve	Solen. Valve control
14	EVASA	Channel A addit. Opening solen. Valve	Solen. Valve control
15	EVSB	Channel B welding solen. Valve	Solen. Valve control
16	EVASB	Channel B addit. Opening solen. Valve	Solen. Valve control

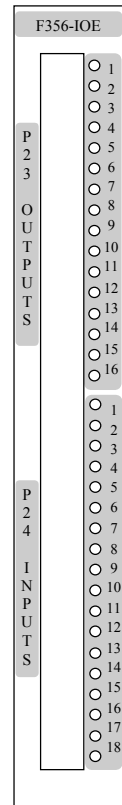

P23 . Functional description of signals

Pin	Signal	Function
-----	--------	----------

1	WALLSTA	Stepper A pre-alarm. Active at +24V. This output is activated as a function of the programming of the stepper concerned. It does not shut down the cycle. It is an indication that the counter is approaching the Stepper Stop threshold. Consult the programming manual for the activation of this function. The message is memorised in the alarm history.
----------	----------------	--

2	WALLSTB	Same as WALLSTA, but for channel B.
----------	----------------	-------------------------------------

3	ALLSTA	Stepper A alarm. Active at +24V. This output is activated as a function of the programming of the stepper concerned. Consult the programming manual for the activation/reset of this function. In the machine shutdown condition, the signal can be reset only by setting the counter of the relevant stepper to zero. This can be made via the RESASA (P24-7) input, or through the software reset in the Stepper menu.
----------	---------------	--

P23 . Functional description of output signals

Pin	Signal	Function
4	ALLSTB	Same as ALLSTA but for channel B.
5	RICHRV	Request for Dressing. Active at +24V. This output is activated as a function of the programming of the stepper concerned. Consult the programming manual for the activation/reset of this function. In the machine shutdown condition, the signal can be reset only by setting the counter of the relevant stepper to zero. This can be made via the RAVOK (P24-9) input or through the software reset in the Stepper menu.
6	RICHEL	Request for electrodes change. Active at +24V. Led indicator illuminated. Same as for request for dressing but it devoted to the electrodes change. The validation is to be carried out with the CHGEOK (P24-10) input.
7	ALARM1	Signalling. Active at +24V. It does not interrupt the processing cycle. Diagnostic alarm (from E001 to E050). Generally, it is reset automatically but it can be fitted with a shutdown function in the Setup menu. See chapters on Alarms and Setup in the programming section.
8	ALARM2	Machine alarm. Active at +24V. It shuts down the cycle. It concerns faults, errors in programming and errors in wiring of both the control device and the machine. It can be reset by pressing the reset key on the small keyboard or from the RESAH dedicated input. It is active until the cause has not been removed.
9	UNDCURR	Undercurrent. Diagnostics. Active at +24V. It does not shut down the cycle. It is always activated together with the alarm 1, when the current value read by the sensor is lower than the programmed threshold. A number of causes may generate it, e.g.: No current or limit threshold, etc... It can be of use when intervention on faulty welds is needed.
10	OVRCURR	Overcurrent. Diagnostics. Active at +24V. It does not shut down the cycle. Same as Undercurrent but the current value is in excess.
11	READY	Control device ready. Active at +24V. This output is activated when the control device is ready to execute a welding cycle. When Alarm1 or Alarm2 is generated, this output is low.

P23 . Functional description of output signals

Pin	Signal	Function
12	STATUS	Welding current enable. Active at 24V. It indicates the condition for Weld Yes; when this function is enabled, this output is high. (see also WeldYes)
13	EVSA	Piloting output of the channel A welding solenoid valve. Active at +24V. It is activated by the corresponding start and is protected through interlocking (consisting of 2 relays) which inhibits the simultaneous call of channel B. If the Start signal is dropped before the pressure cycles are completed, the call is not recognised and the electrodes go open again. When the pressure cycles are completed, the Start signal stays in the self-holding mode up to the end of the Holding cycles. (See cycle time diagrams in the programming manual).
14	EVASA	Active at +24V. Piloting output of the channel A additional opening solenoid valve. It is also known as pre-stroke or pre-approach solenoid valve. Activated by the CEVASA control, this output is protected by an interlocking, consisting of 2 relays, which inhibits the simultaneous call of channel B pre-stroke. See cycle time diagrams for the relevant timing.
15	EVSB	Piloting output of the channel B welding solenoid valve. Same as EVSA but for channel B.
16	EVASB	Piloting output of the channel B additional opening solenoid valve. Same as EVASA but for channel B.

10.2 P24 . Description of input signals

18-way, 3.5mm pitch linear connector for disconnectable terminals

Pin	Signal	Description
1	STARTA	Start channel A
2	STARTB	Start channel B
3	CEVASA	Additional opening A control
4	CEVASB	Additional opening B control
5	SALDASI	Weld Yes
6	SOLOPR	Pressure only
7	RESASA	Stepper A alarm reset
8	RESASB	Stepper B alarm reset
9	RAVOK	Dressing done
10	CHGEOK	Electrodes change done
11	CODE0	Bit 0 program code
12	CODE1	Bit 1 program code
13	CODE2	Bit 2 program code
14	CODE3	Bit 3 program code
15	CODE4	Bit 4 program code
16	CODE5	Bit 5 program code
17	CODEP	Program code parity code
18	RESAH	Alarm 2 reset

P24 . Functional description of input signals

Pin	Signal	Function
1	STARTA	Channel A Start. Active at +24V. The control device activates the EVSA output (Gun A call) and executes the welding program demanded. If Start is interrupted before the pressure cycles have elapsed, the EVSA output is deactivated and electrodes open. When pressure cycles are got over, the Start signal stays in the self-holding mode up to the end of the frequency cycles.
2	STARTB	Same as STARTA but for channel B.
3	CEVASA	Control to solenoid valve for additional opening A. Active at +24V. Start of electrodes pre-approach; it is enabled and disabled with 0 to 24V ramp up, (pulse type). Signal reading time < 100mS. If not used, this input is to be connected directly to +24V.
4	CEVASB	Same as CEVASA but for channel B.

P24 . Functional description of input signals

Pin	Signal	Function
5	SALDASI	<p>Weld Yes. Active at +24V. It enables the welding current. Also the following functions are to be active: Weld Yes in the Setup stage* and the selector located on the front of IOB card. The control device activates the Status output (+24V) when the Weld Yes function is enabled. * See programming manual.</p>
6	SOLOPR	<p>Pressure only. OFF active. It is used for the gun setup. Usually at 24V, if it is open during the welding sequence, the following occurs:</p> <ul style="list-style-type: none">• The sequence is interrupted. Electrodes are closed and under pressure.• The control device waits for 24V signal on this input• The RICHSALD output is low <p>If the Start signal is released, the call is interrupted and the gun opens. If SOLOPR goes high, the sequence is resumed, the control device makes the RICHSALD output go high and the process continues according to the status conditions of SALDASI (WELDYES) and CONSALD (CONS.TO WELD.) functions.</p>
7	RESASA	<p>Stepper A alarm counter reset. Active at +24V. It clears the counter of spots active on channel A, if no dressing or electrodes change is active.</p>
8	RESASB	<p>Same as RESASA but for channel B.</p>
9	RAVOK	<p>Validation of Dressing done. Active at +24V. This input is to be activated when the electrode dressing has been done (further to the Request for Dressing Signaling). It inhibits the alarm signaling, sets the welding spot counter to zero and increments, by one unit, the counter for dressing operations done in the electrodes wear program.</p>
10	CHGEOK	<p>Validation of electrodes change done. Active at +24V. This input is to be activated when the electrode dressing has been done (further to the Request for Electrodes Change Signaling) It inhibits the alarm signaling and sets to zero all counters of stepper concerned.</p>
11	CODE0	<p>Active at +24V.</p>
12	CODE1	<p>Inputs reserved for the selection (with binary code) of the welding program to initialise at Start.</p>
13	CODE2	
14	CODE3	
15	CODE4	
16	CODE5	<p>When the Start function is active, the control device reads the active code on these inputs and performs the relevant program (see list of codes on page 47). Facility to use up to 64 welding programs. IMPORTANT: To select program 64, all inputs of program codes are to be 0V logic.</p>

P24 . Functional description of input signals

Pin	Signal	Function
17	CODEP	Parity Code. Active at +24V. It is used only on robot operated lines. It is used for the logic check of CODE0....5 inputs and is dependent on the setting done in the Setup menu. (see list of codes on page 47). Warning! If not used, this input must be disabled (see Setup section of programming manual).
18	RESAH	Hardware alarm reset. Active at +24V. It inhibits the machine shutdown (Alarm 2) occurred during the processing.

Card layout: Standard setting of jumpers

J1: 2-3
JP1: Off

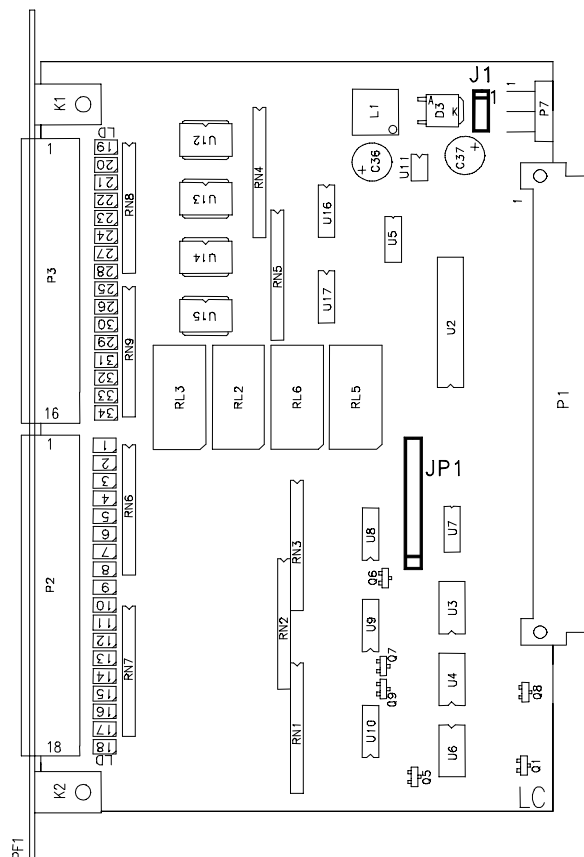

WHITE PAGE

11. F376-OPC Field-Bus InterBus-S Card (Profile F-IBS/03)

11.1 Characteristics

The F376-OPC card enables the welding I/O functions towards the field to be managed, as an alternative to the IOE field cards. This data communication occurs by optical fiber transmission through a serial bus, compatible with the InterBus-S protocol.

InterBus-S is one of the most common communication standards in the field of automation.

The F376-OPC card enables exchange of up to 12 words. The actual amount of exchanged data depends on the communication *Profile* defined for any specific application. The word "Profile" identifies a particular configuration of the exchanged data. The F376-OPC card is associated to the F-IBS/03 Profile type.

From the functional standpoint, the card is divided into two separate parts: the first part comprises the interface electronics towards the control device and is powered by the internal bus; the second part comprises an optical interface circuit towards the field powered by an external 24Vdc through the P25 connector.

Thus the InterBus-S serial communication, as it is autonomously powered, is not interrupted when the power to the control device is OFF.

The InterBus-S interface is achieved through the IBS SUPI 3 OPC (**O**ptical **P**rotocol **C**hip) component, that ensures a high degree of operational security and an independent diagnostics capability in the quality and level of the optical fiber based signal.

11.2 Optical connectors InterBus-S

The connectors used for the optical fibers are of the F-SMA type, in accordance with the **InterBus-S DIN 19258** standard. Please refer to this specification for the connection topology and the optical fiber type to be used.

REMOTE IN

Remote communication connections towards the preceding device:

DI1: Output **DO1:** Input

REMOTE OUT

Remote communication connections towards the following device:

DI2: Output **DO2:** Input

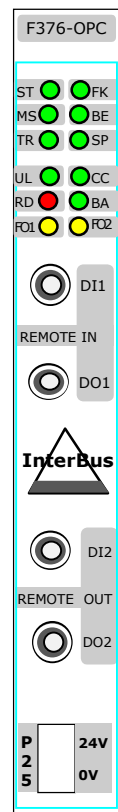

WARNING

When not in use, the closing cap must always be placed on the optical connectors.

11.3 InterBus-S interface power supply

There is a P25 connector on the front panel to supply the InterBus-S interface.
Connector type: 2 way, 5.08 pitch, disconnectable terminals.

Power supply input characteristics:

- Acceptable Input voltage: 24Vdc -15%+10%
- Max. Absorption: 125mA

The 0VIB return signal is not connected to the ground PE.

Pin	Signal	Description
1	+24VIB	Power
2	0VIB	Return

11.4 Description of status LEDs

There are 2 groups of LEDs on the front panel indicating the status of some I/O signals and of the InterBus-S port.

ST FK

MS BE

TR SP

ST-FK-MS-BE leds

These LEDs indicate I/O functions dedicated to the welding process

Led	Signal	Condition	Related bit
ST	START	Welding sequence start	Control Word 1 Bit 0
FK	FINESEQ	Sequence end active	Status Word 1 Bit 0
MS	STATUS	Weld YES enabled	Control Word 1 Bit 7
BE	READY	Control device ready	Status Word 1 Bit 4
TR	Transmit Receive	Communication through PCP protocol active.	None
SP	SPARE	Not used. Available for future uses.	

UL CC

RD BA

FO1 FO2

UL-RC-RD-BA LEDs

These LEDs indicate InterBus-S port communication functions

Led	Color	Normal status	Condition
UL	Green	On	When OFF it indicates a reset condition
RC	Green	On	when OFF it indicates <i>InterBus-S reset</i> active
RD	Red	Off	When ON it indicates BUS <i>InterBus-S</i> disabled
BA	Green	On	When OFF it indicates <i>InterBus-S</i> inactive
FO1	Yellow	Off	When ON it indicates a fault on the REMOTE-IN optical interface (e.g. reached limit level of the optical fiber signal)
FO2	Yellow	Off	When ON it indicates a fault on the REMOTE-OUT optical interface (e.g. reached limit level of the optical fiber signal)

Identification code (ID Code)

The welding control devices are considered by the *InterBus-S* net as digital devices belonging to the *Profile-conforming digital devices with I/O addresses (PROFILE DIO)*. This functional category corresponds to the **decimal identification code** (ID code) **47 (2f hexadecimal)**.

11.5 Error conditions with the control device shut down

During InterBus-S line working, the communication protocol recognizes two shut-down conditions of the control device:

- 1 - When the control device is still OFF and the F376-OPC card is powered (24V on P25), by starting the communication on the InterBus-S line, the F376 card generates the ID38_{hex} "µP_Not_Ready" identification code on the bus to tell the Bus Master that the device has not been initialized.
- 2 - Under normal operating conditions of the InterBus-S Bus, if the control device is switched OFF, the F376-OPC card generates a "Module error" type error and sends a "Peripheral error indication" signal to the Bus Master.

11.6 Optical power regulation

The SUP1 3 OPC expands the data transmission functionality thanks to the help of the optical transmission techniques. This device is able to autonomously regulate the optical power transmitted by the optical fiber cables (FOC), thus compensating the thermal effects and the component aging.

The automatic regulation is only possible in the case of a communication occurring through a device with this same functionality. In other cases the optical intensity is kept to a standard level, which is settled by the JP23-JP24-JP25-JP26-JP27 bridge configuration, and is determined through a particular procedure carried out while producing the card.

WARNING

It is in any case forbidden to change the JP23-JP27 bridge configuration during the card setup and/or replacement.

Card layout.

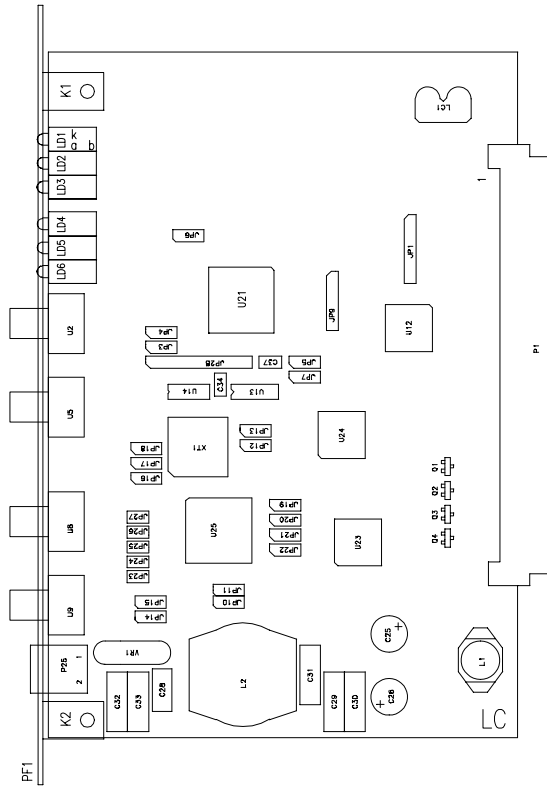

12. F386 Ethernet 100Base-T and CANbus communication module

Serial and CANbus communication card for Ethernet 10/100Base-T IEEE802.3 nets.

This module enables the welding control to be connected to a serial network of the Ethernet type for communication towards the WMS centralizer.

It can be used as an alternative to Profibus (F354-PBS) communication card, to the WMSNET (F355-NET) communication card or to the previous Ethernet 10Base-T (F372-ETH e F381-ETH) cards.

The CANbus port is a serial connection which allows the remote management of I/O signals.

The communication protocol is settled by the user.

The TCP/IP address of the Ethernet section is memorised in a "DATA KEY" (DK) device with removable key accessible from the front panel.

The key can be removed to enable the control device to be replaced in case of breakdown without having to carry out manual net-configuration operations on the replacement control device.

To set the addresses for connection to the network, please consult the programming manual.

12.1 Technical features

12.1.1 Ethernet section

- Compatibility: IEEE 802.3, 802.3u standards
- Transmission speed: 10/100Base-T
- Connector: RJ-45 8-pole

12.1.2 CANbus section

- Bus type: according to ISO 11898-1, ISO 11898-2 (High Speed)
- Connector: Sub-D 9-pole according to CiA-DS102
- CAN interface galvanic isolation
- Transmission speed: max 1 MByte/s

12.2 Front panel

12.2.1 P28 – CANbus connector

Sub-D 9-pole male type

Pin	Signal	Function
1	-	Reserve
6*	GND	CAN Ground
2	CAN_L	CAN_L bus line (dominant low)
7	CAN_H	CAN_H bus line (dominant high)
3*	CAN_GND	CAN Ground (optional)
8	-	Reserve
4	-	Reserve
9	CAN_V+	CAN external positive supply (optional line)
5	CAN_SHLD	CAN Shield (optional)
Shield	PE	

Pins 3 and 6 are interconnected to each other

12.2.2 CANbus status LED's

LED	Colour	Meaning	Condition
RUN	Green	CAN peripheral status	On = active
ERR	Red	Anomaly	On = generic anomaly

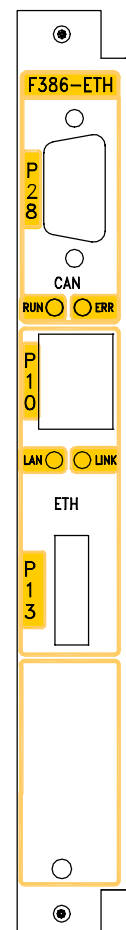

12.2.3 P10 Ethernet 100Base-T connector

RJ45 8-pole female shielded type MDI configuration

Pin	Signal	Function
1	TD+	Positive data transmission
2	TD-	Negative data transmission
3	RD+	Positive data reception
4	-	Not used
5	-	Not used
6	RD-	Negative data reception
7	-	Not used
8	-	Not used
Shield	PE	

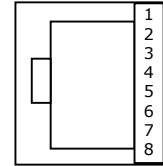

P10 connector pinning (front view)

12.2.4 Ethernet status LED's

LED	Colour	Meaning
LAN	Green	ON when data transmission is in progress
LINK	Yellow	OFF when there is a line fault

12.3 Ethernet connection cable

12.3.1 Features

- Cable type (100Base-T): Category 5 or 5e UTP up to 100m.
- Cable type (10Base-T): Category 3, 4, 5 or 5e UTP up to 100m.

12.3.2 Connection type

The RJ45 connection layout depends on the type of connection of the used HUB input port. It can be a HUB with MDI connection or a HUB with MDI-X connection. Before making the cable please check the port type on the HUB.

12.3.2.1 Connection for HUB with MDI-X port

In this case the connection between the two connectors is "Pin to Pin".

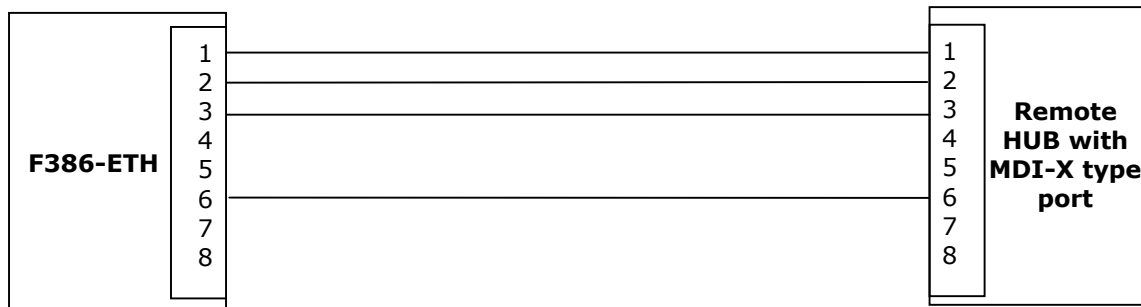

12.3.2.2 Connection for remote HUB with MDI port

In the connection with MDI port the signals are "crossed".

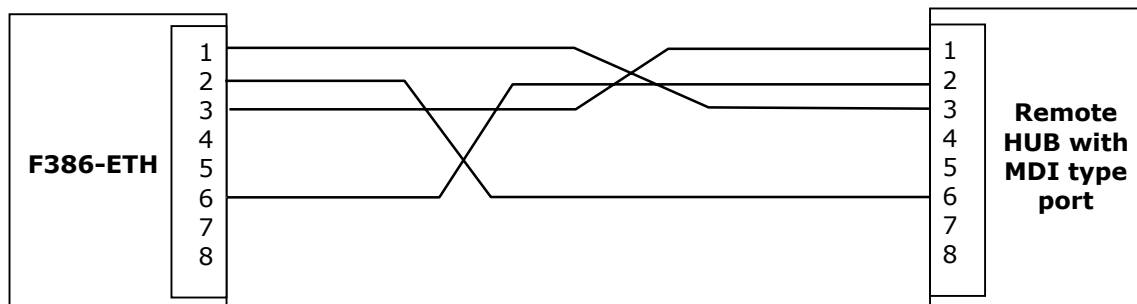

Card layout

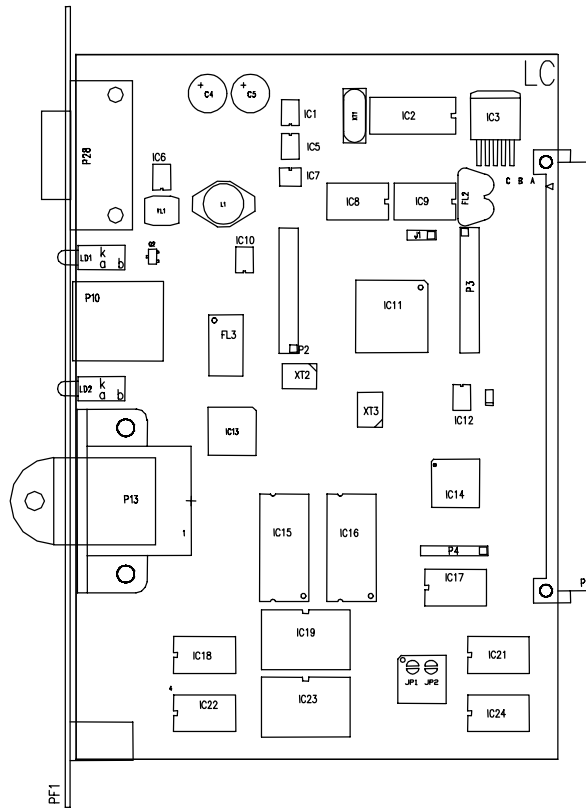

WHITE PAGE

13. F383-COM RS422 Serial communication card

RS422 serial interface for the communication with a remote device.

The communication protocol depends on the functional goal that has to be achieved.

Features:

Data transmission speed : 19,2 kBit/s
Maximum length : 1000m

TXD-RXD LEDs

The 2 green LEDs TXD and RXD on the front panel are used to monitor the serial port.

When the communication occurs properly, both LEDs are blinking.

In case of an anomaly in the serial port or in the cable, one or both LEDs remain switched ON or OFF.

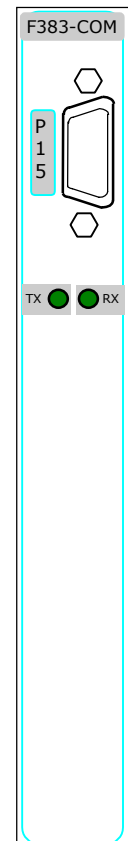

13.1 P15 – Connection port

Sub-D 9-pin Female Connector

Pin	Signal	Function
5	RXD-	Inverting differential input
9	nc	Not connected
4	RXD+	Non-inverting differential input
8	nc	Not connected
3	TXD+	Non-inverting differential output
7	nc	Not connected
2	TXD-	Inverting differential output
6	nc	Not connected
1	GND	Ground

Recommended connection components:

- Connector:
Shielded, male 9-pin SUB-D connector
- Local and remote connection cable, out of the cabinet, 500m max
Shield connected to the connector case
Serial cable features:
2 twisted pair + 1 wire, single-shield
0,35mmq minimum section
E.g. LappKabel Unitronik Li2YCY (TP)

Card layout

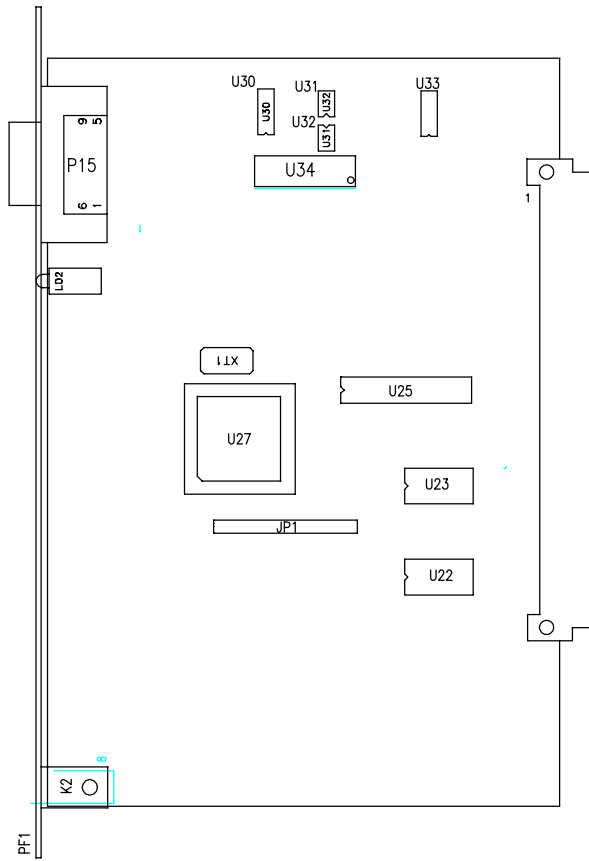

14. InterBus-S Profil F-IBS/03

14.1 General description

A specific data communication *Profile* has been integrated into the firmware of the modular control Weld334m, which is automatically activated in the versions with Interbus-S type serial Fieldbus communication module. This *Profile* was developed for applications in the field of resistance welding. The complete range of functions may be used by inserting modules F376-OPC (Interbus-S connections with fibre optics, OPC controller chip) into the control 334m.

The profile is a document describing data exchange with the peripheral in question, defining their interpretation in detail. The reference unit for data exchange is the WORD. Each WORD is made up of 16 bits, numbered from 0 to 15. The data are subdivided into two categories: data from remote devices towards the welding control, identified as *Control Words*; data from the welding control towards the remote devices, identified as *Status Words*.

It should be remembered that these words are specific to this application and are not compatible with applications other than those described in this chapter.

The Profile F-IBS/03 comprises 3 *Control Words* (1-3) and 3 *Status Words* (1-3).

For connections, specifications and materials, please see the documentation: **InterBus-S DIN 19258 WELD-COM PROFILE C0**.

14.1.1 Control Words

Control Words are commands relating to the welding sequence sent from the remote interface device to the welding control.

Control Word 1

Control Word 1 defines the commands relating to the fundamental welding functions.

Bit	Description	
0	START	
1	RAVOK	
2	STATUS Servovalvole	
3	CHELOK	
4	Reset Allarme	
5	Reset Allarme	See next table
6	Reset Allarme	
7	SALDA SI/NO	
8	CODE0	
9	CODE1	
10	CODE2	
11	CODE3	
12	CODE4	
13	CODE5	
14	CODE6	
15	CODE7	

Control Word 1 – Functional description

Bit	Signal	Function
0	Start weld program	Bit = 1. Start Command. The number of the welding program is acquired and the related cycle is started.
1	RAVOK	Bit = 1. Electrode dressing completed. The signal is sent to the control that the requested dressing has been completed. The signal must be active for at least 100 ms.
2	Servo valve	Bit = 1. Authorisation to enable the servo valve. When this bit is at 1, the control can send the ENSERV signal to the servo valve
3	CHELOK	Bit = 1. Electrode change completed. The signal is sent to the control that the requested electrode change has been completed. The signal must be active for at least 100 ms.
4	Reset Alarm	Bit = 1. All alarms no longer active will be reset without further action from the welding control.
5/6	Reset alarm	See next table
7	WELD YES/NO	Bit = 1. Enable cycle with current The welding cycle must be performed with current, that is to say commanded by the power group.
8/15	Program code	Selection of welding program (1-255) in binary code.

Functional description of bits 5 and 6 of Control Word 1

Bit 5	Bit 6	Description	Action taken
0	0	Reset alarm	All active error messages are reset
1	0	Reset alarm with Sequence End	All active alarms are reset. If the START signal is still present, the Sequence End signal will be activated.
0	1	Reset alarm with Sequence Repeat	All active alarms are reset, and if the START signal is still present, the sequence is repeated.
1	1	Not used	

Control Word 2

Control Word 2 defines the commands relating to management of the supplementary functions of the steppers, and of accessory functions.

Bit	Description
0	Reset stepper gun 1
1	Reset stepper gun 2
2	Reset stepper gun 3
3	Reset stepper gun 4
4	Reset stepper gun 5
5	Reset stepper gun 6
6	Reset stepper gun 7
7	Reset stepper gun 8
8	Not used
9	Not used
10	Not used
11	Not used
12	Not used
13	Start log
14	Stop log
15	Reset communication fault

Control Word 2 -Functional description

Bit	Signal	Function
0/7	Reset gun 1+8 stepper	Bit = 1. Reset gun no. stepper recognized. Information that "stepper counters no.s reset" is confirmed (see specific description at para. 14.2).
8/12	-	Not used.
13	Start Log	Data storage for the protocol function for test pieces begins.
14	Stop Log	Data storage for the protocol function for test pieces stops.
15	Reset Communication Fault	Communication fault alarm is reset (Status word 2 - bit 15).

Control Word 3

Control Word 3 defines the Spot Index.

The Spot Index is an index (that can be defined from 1 to 65535) used to select a welding spot contained in a database specifically created and managed through the FASE SALDATURA WMS centralisation program.

Each Spot Index in this database is associated to a working name (generally the name of the spot to be welded) and a reference to the welding program that must be performed.

In each welding control, the necessary part of the database is saved through the WMS centralisation program.

Signals sent by the Weld334m on the welding status, (diagnostics, program called up, electrode pressure, etc.) are integrated with a Spot Index value and the name of the welding spot.

WARNING

If there is no specific parameter setting, where a program code value different from zero (Control Word 1 bit 8-13) and a Spot Index value different from zero (Control Word 3 bit 0-15) appear, the welding control will perform the selected sequence with the program code.

Bit	Description
0	Spot index selection bit 0
1	Spot index selection bit 1
2	Spot index selection bit 2
3	Spot index selection bit 3
4	Spot index selection bit 4
5	Spot index selection bit 5
6	Spot index selection bit 6
7	Spot index selection bit 7
8	Spot index selection bit 8
9	Spot index selection bit 9
10	Spot index selection bit 10
11	Spot index selection bit 11
12	Spot index selection bit 12
13	Spot index selection bit 13
14	Spot index selection bit 14
15	Spot index selection bit 15

For further information, please see the WMS manual.

14.1.2 Status Words

Status Words indicate to the remote interface device the status of the welding sequence, and the status of the control and functionality of accessories in general.

Status Word 1

Status Word 1 defines the standard welding outputs

Bit	Description
0	FINE SEQ.
1	RICHRAV
2	PREALARM
3	RICHEL
4	READY
5	ALARM1
6	PROCESS-CONTROL
7	STATUS
8	Danger Alarm (circuit breaker tripped)
9	STSERV
10	OVERCURRENT
11	UNDERCURRENT
12	Hardware alarm (ALARM 2)
13	reserve
14	reserve
15	reserve

Status Word 1 –Functional description

Bit	Signal	Function
0	SEQ. END	Bit = 1. When operating in "single spot" mode, indicates the end of the sequence, if the welding cycle has been completed without anomalies.
1	RICHRAV	Bit = 1. The welding control requires electrode to be dressed The bit is set to 0 when dressing gives confirmation through the signal "electrode dressing end".
2	PREALARM	Bit = 1. One of the electrodes has reached the programmed value for warning of electrode wear
3	RICHEL	Bit = 1. One of the electrodes has reached the value programmed for end of electrode life. The maximum electrode life has been reached. The bit is set to 0 when the counter has been reset.
4	READY	Bit = 1. The welding control is ready to perform a welding cycle.
5	ALARM1	Bit = 1. During the last welding cycle an anomaly occurred in the welding process. The bit will be set to 0 after "reset alarms".
6	PROCESS-CONTROL	Bit = 0. The diagnostic controls on the welding spot being performed are not activated (normal welding mode or current sensor disabled) Bit = 1. Diagnostic controls on the welding spot being performed are activated (monitor welding

		mode or constant current).
7	STATUS	Bit = 1. Execute "welding cycle with current" enabled. The welding cycle will be executed with current, that is to say under command of the power group.
8	Danger Alarm (Circuit br. trip.)	Bit = 1. Signals that the control has detected the condition of "current without start".
9	STSERV	Bit = 1. Signals that the proportional valve has reached the required setup value.
10	MAXPWR	Bit = 1. Signals that the control is operating with the minimum admissible striking angle.
11	UNDERCURRENT	Bit = 1. Signals that the welding current measured is below the minimum tolerance admissible.
12	Hardware Alarm (ALARM 2)	Bit = 1. Signals the presence of an alarm with error code > 50 (planned alarm).
13/15	-	Not used

Status Word 2

Status Word 2 defines the commands relating to the management of supplementary stepper functions and of accessory functions.

Bit	Description
0	Reset stepper gun 1
1	Reset stepper gun 2
2	Reset stepper gun 3
3	Reset stepper gun 4
4	Reset stepper gun 5
5	Reset stepper gun 6
6	Reset stepper gun 7
7	Reset stepper gun 8
8	Not used
9	Not used
10	Not used
11	Not used
12	Not used
13	Not used
14	Not used
15	Communication fault

Status Word 2 – Functional description

Bit	Signal	Function
0/7	Reset stepper gun 1+8	Bit = 1. Stepper gun no. reset. Resetting of stepper counter no. is confirmed. (see description of spec.s at par. 14.2).
8/14	-	Not used.
15	Communication Fault	Error during storage on network support of data relating to the protocol function for test pieces

Status Word 3

Status Word 3 defines two Bytes included between bits 0-7 and bits 8-15 to communicate the technological parameters necessary to manage an electric gun, such as electrode closing force (WELD FORCE) and the thickness of the part to be welded (ELEMENT THICKNESS).

Bit	Description
0	Weld Force bit 0
1	Weld Force bit 1
2	Weld Force bit 2
3	Weld Force bit 3
4	Weld Force bit 4
5	Weld Force bit 5
6	Weld Force bit 6
7	Weld Force bit 7
8	Element Thickness bit 0
9	Element Thickness bit 1
10	Element Thickness bit 2
11	Element Thickness bit 3
12	Element Thickness bit 4
13	Element Thickness bit 5
14	Element Thickness bit 6
15	Element Thickness bit 7

Status Word 3 – Functional description

Bit	Signal	Function
0/7	Weld Force	<p>With this byte the control communicates the value of the electrode force defined in the welding programme. It is a parameter that replaces the analog signal for application of the proportional servovalve.</p> <p>The field of regulation of the force is between 0-1275 daN (one bit is the equivalent of 5daN).</p>

8/15	Element Thickness	<p>With this byte the control communicates the element thickness defined via WMS and assigned to the welding spot.</p> <p>The field of regulation of the thickness is between 0-12.75 mm (one bit is the equivalent of 0.05mm).</p> <p>This parameter is located in the WMS, in the User Parameters area of the welding programme.</p>
-------------	--------------------------	--



Please see the WMS programming manual.

14.2 Robot directives update

Use of Status and Control Word 2 within robot communication.

Within the FASE control device (only 334m) the 2nd Interbus Word is for the communication extended between the device and the robot for the information exchange concerning the already reset counter, after activating the *reset counter* with the number of the program. Bit 0-7 output Fase (Reset gun 1-8) indicates that counter has already been reset.

The information is confirmed by the robot via the inputs Bit 0-7 (Reset gun confirmation). The detailed description of this function is given in the Programming Manual of the Weld 334m.

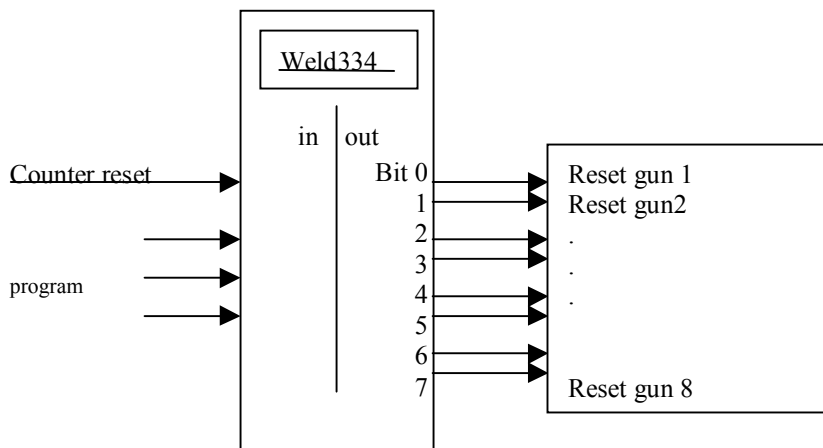

The gun, selected by the program, is reset by Word 2, and this selection is transmitted in parallel on the gun outputs 1-8, and controlled by the *Reset Counter* Interbus and by the number of the selected program.

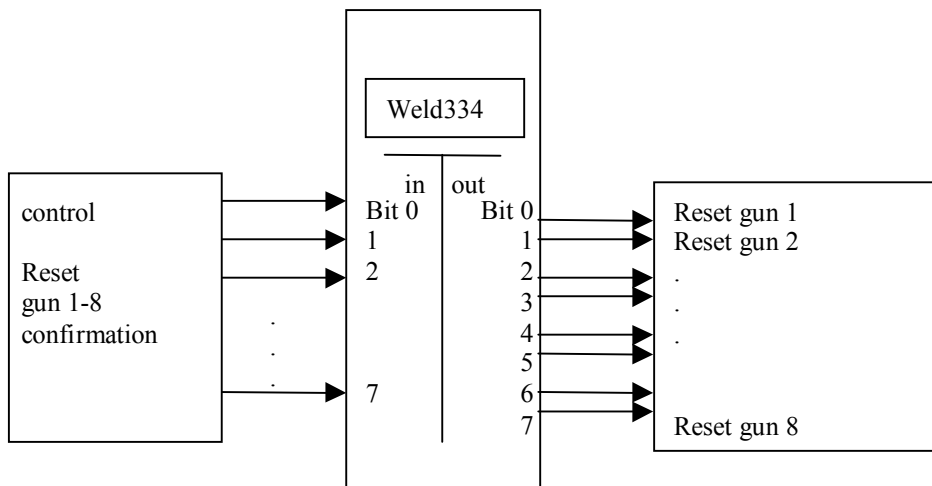

The selected gun outputs are confirmed via the *Reset Gun Confirmation Control*.

APPENDIX

APPENDIX A - Maintenance

Maintenance operations

Replacing the cards is a very simple task which poses no problems.

The wiring connections with the welding machine cannot be exchanged between one another and the connector ID code is also recalled on the front panel.

To avoid doing wrong connections with similar connectors, **DO NOT REMOVE** the polarising device which is fitted to several connectors of the cards.

To make the connection of the card on the bus easier, it is better to strip the card pack from the container.

Always check whether jumpers are present on the card. If so, check they are done correctly.

Replacing the modular cards

1. Switch off the machine and disconnect wiring.
2. Disassemble the control device from the machine support.
3. Remove the front panel by undoing the 3 fastening screws.
4. Disconnect the card to be replaced paying utmost care in doing this operation.

Front part fastening screws

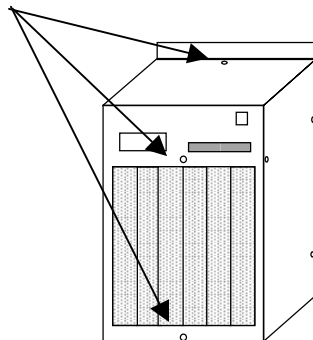

5. Check on the new card for the presence of jumpers and, if need be, set them in the correct way.
6. Fit the new card into the rack and make sure that the P7 3-way connector fits correctly into the bus.
7. Put the card pack in place again in the container and fasten it by using its screws.
8. Re-install the front part making sure that the PS connector fits properly into the window then screw down the front part.
9. Re-install the control device onto the machine.
10. Connect wiring again.

Replacing the CPU card

The CPU card has its own (compulsory) position on the P1 of the bus and is connected to the display module via a 10-way flat cable.

The P7 3-way connector does not take 24V I/O supply from the bus, it takes the privileged power supply to power the programming unit from the RS485 port (P1).

How to replace the card:

1. Switch off the machine and disconnect wiring.
2. Disassemble the control device from the machine support.
3. Remove the front panel by undoing the 3 fastening screws.
4. Disconnect the card to be replaced paying utmost care in doing this operation.
5. Disconnect the display connector from P3. Pay utmost attention in doing this.
6. Check if the new card is fitted with the buffer battery for the permanent memory. Verify jumpers on the connectors JP3 and JP6; they must be as follows:
JP3: 3-4 and 6-7 jumpers JP6: 1-2 jumper
7. Connect the display flat cable to P3 connector.
8. Insert the new card onto the bus making sure that the P7 connector is fitted correctly.
9. Put the front part in place again making sure that the PS connector fits correctly into the window then fasten the front panel with the screws.
10. Re-install the control device onto the machine.
11. Connect wiring again.

Replacing the power feeder

The power feeder card can be easily replaced. Check that the internal 250V, 1.5A fuse for 24VE supply is present before installing the new card.

How to replace the card:

1. Switch off the machine and disconnect wiring.
2. Disassemble the control device from the machine support.
3. Remove the front part buy undoing the 3 fastening screws.
4. Remove the 5 screws fastening the power feeder to the fastening brackets.
5. Disconnect the power feeder from the bus.
6. Check that network sync jumpers on the power feeder are set in the correct way (internal or external, see paragraph 3.4).
7. Connect the new power feeder making sure it fits properly into the connectors J1 and J2 of the bus.
8. Screw it down.
9. Put the front part in place again making sure that the PS connector fits correctly into the window then fasten the front part with the screws.
10. Re-install the control device onto the machine.
11. Connect wiring again.

Replacing the welding control device

Times indicated refer to a manual welding station

1	Saving the configuration and programs of the control device to be replaced on a Ram-Card	1 Minute
2	Dismantling the control device to be replaced from the welding machine support	3 Minutes
3	Mounting the new control device	3 Minutes
4	Switching On the new control device and verification that no diagnostics alarms are On	1 Minute
5	Inserting the Ram-Card and loading the programs and the configuration of the new control device	1 Minute

Time for replacing the device totals to 9 minutes (approx.).

Modifying a welding program:

The operation is to be carried out by qualified personnel with optimum knowledge of the control device programming.

Time taken up to modify a program depends on the entity of the change:

If only one parameter is to be modified, for instance the welding current value, the operation will take about 45" via the HCM4300 programming unit.

By contrast, if more parameters are to be modified, time can be calculated averagely, by adding approx. 30" for opening the menu concerned to approximately 10" for each modified parameter.

Time for modifying 1 parameter : 45" ~

Time for modifying "n" parameters : 30" + 10 x n

Replacing the battery

3.6V CR2477N type lithium battery.

The battery is housed on the F384 CPU card in an adequate seat which allows the battery to be replaced easily with no need for special operations.

When replacing the battery, data stored on the RAM are not lost. A Supercap type capacitor powers RAMs during the replacement.

Check that the new battery provides the correct voltage before mounting it onto the card. To do this use a tester.

How to replace the battery:

1. Switch off the machine and disconnect wiring
2. Disassemble the control device from the machine support
3. Remove the front part by undoing the 3 fastening screws
4. Draw out the card located sideways the CPU card
5. Disconnect the F384 CPU card and draw it out tilting it sideways
6. Disconnect the small cable of the display
7. Remove the battery clip
8. Draw out the down battery
9. Insert the new battery
10. Mount the clip *
11. Connect the small cable of the display and, tilting the card sideways, fit it into the slot
12. Insert the card close to the F384-CPU making sure that the P7 fits correctly.
13. Put the front part in place again checking that the PS connector fits into the window then fasten the front part by using the screws
14. Re-install the control device onto the machine
15. Connect wiring again

* It is of paramount importance that the battery clip be always fitted.

APPENDIX B – Diagrams and network configurations

Operating diagrams

This section illustrates a few operating diagrams of the control device which allow analysing timing and synchronisms referred to the **Start** and **Emergency** conditions in manual or automated environments.

1 – START recognition with use in automated environment

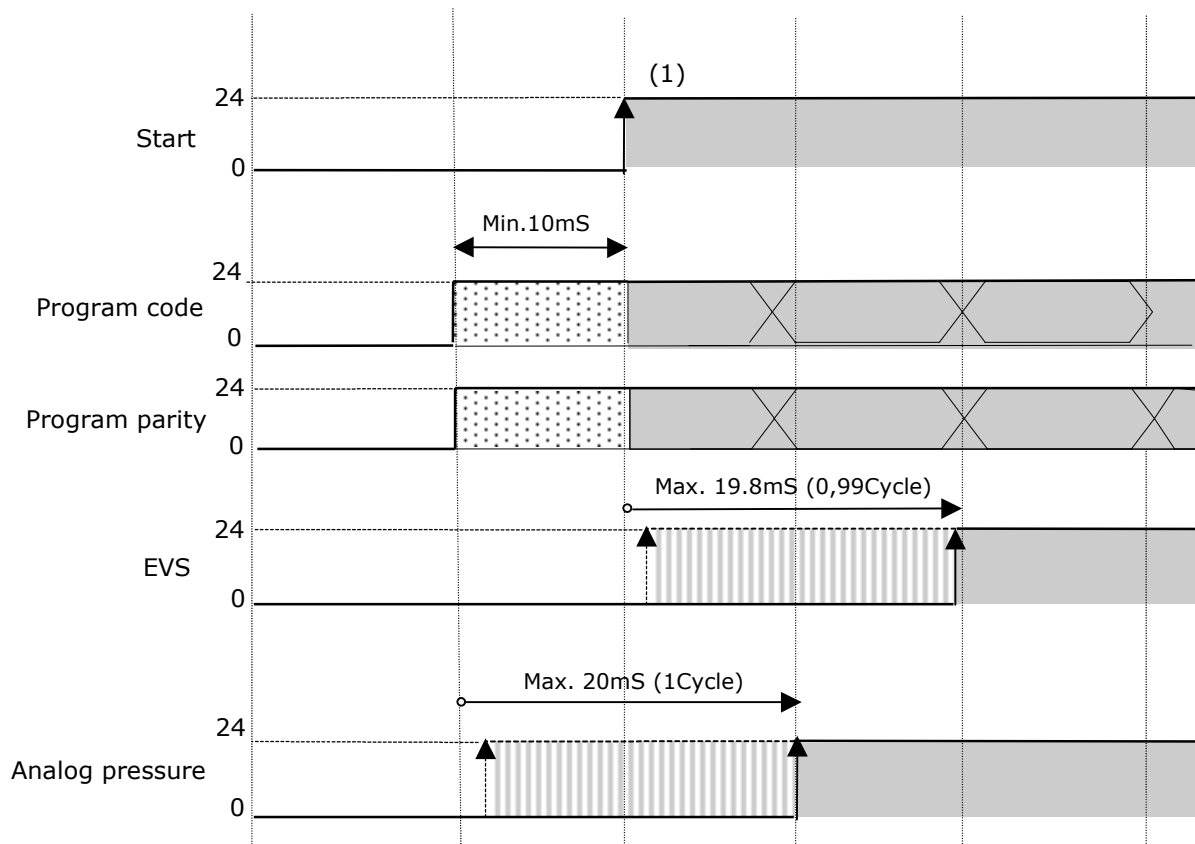

(1) The program code is saved. Any successive changes have not effect.

2 - START recognition with use in manual environment

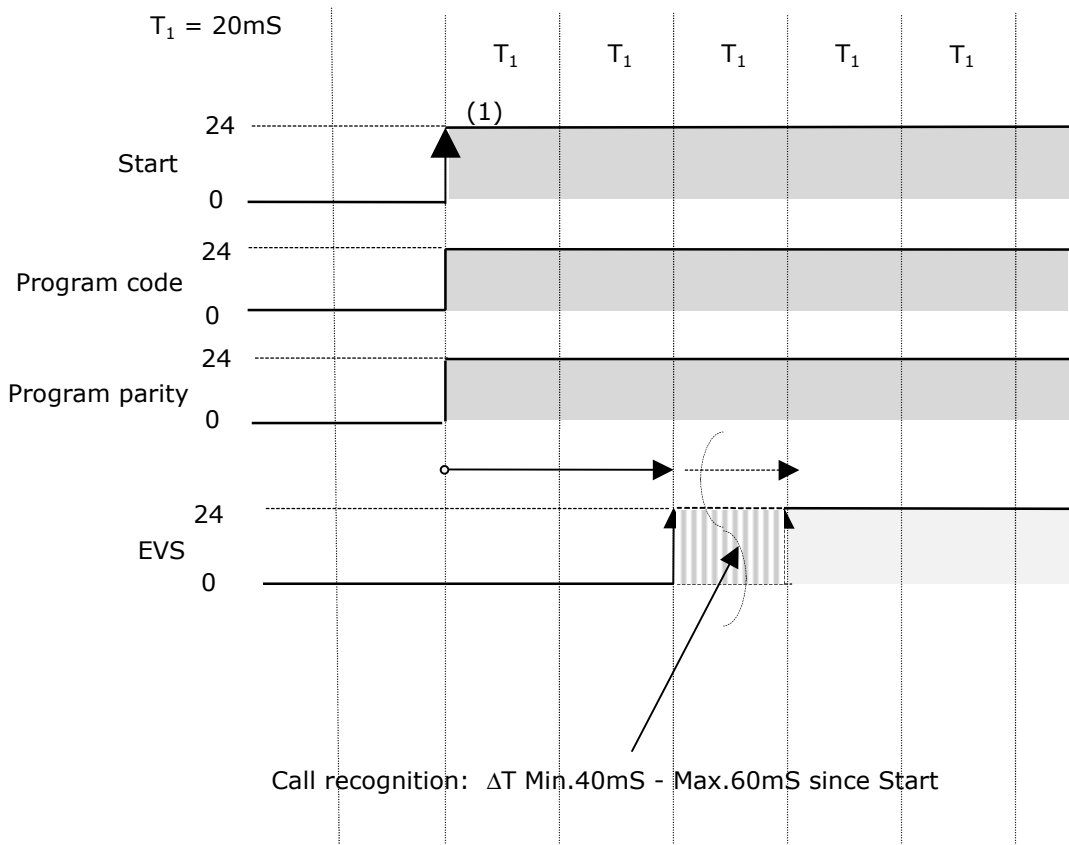

(1) Start and Program Code must stay stable.

3 – EMERGENCY STOP condition : general diagram

NOTE: The Emergency stop signal is active at 0V

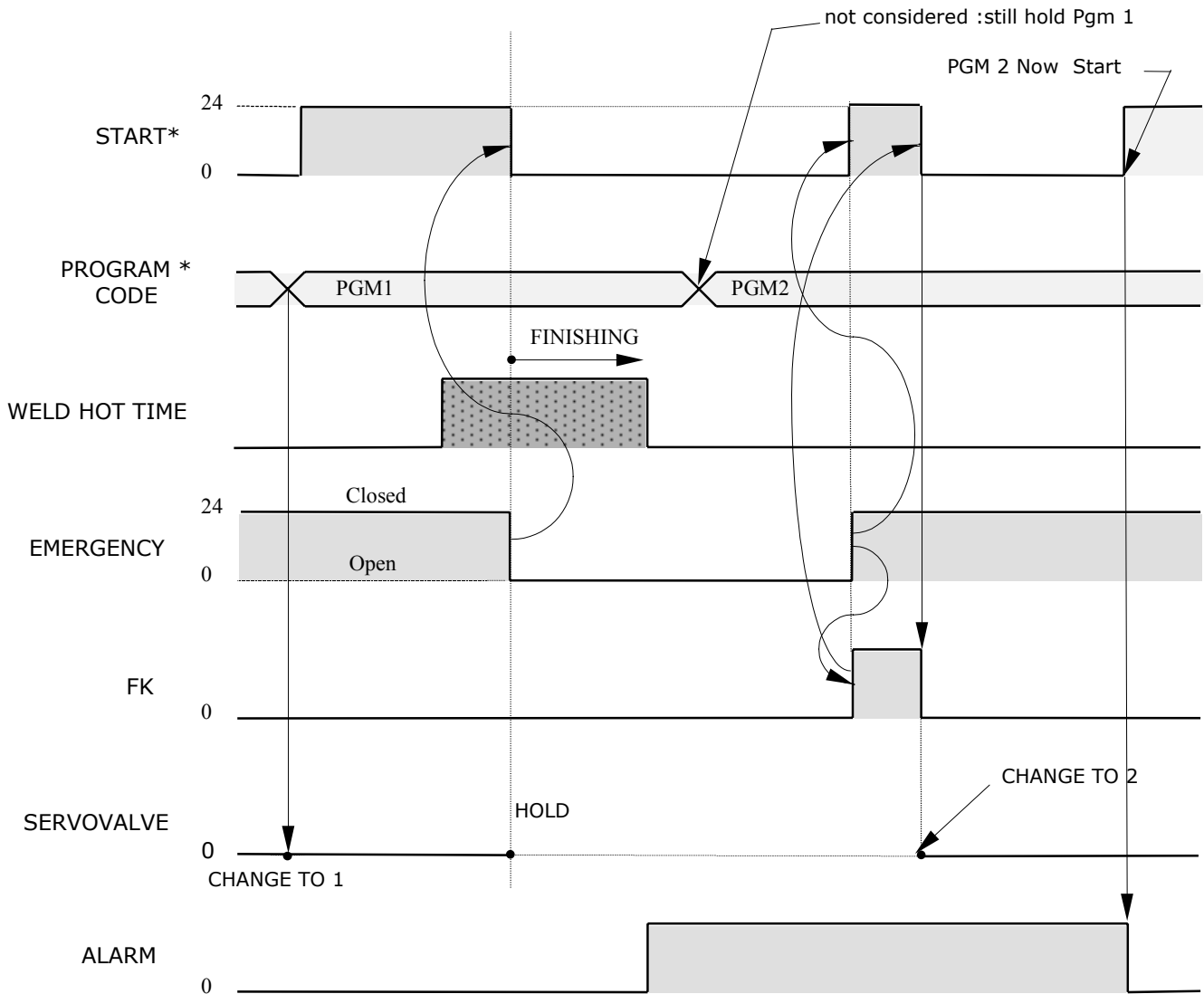

* Given by robot

4 – EMERGENCY STOP condition during or outside the welding pulse

NOTE: The Emergency stop signal is active at 0V

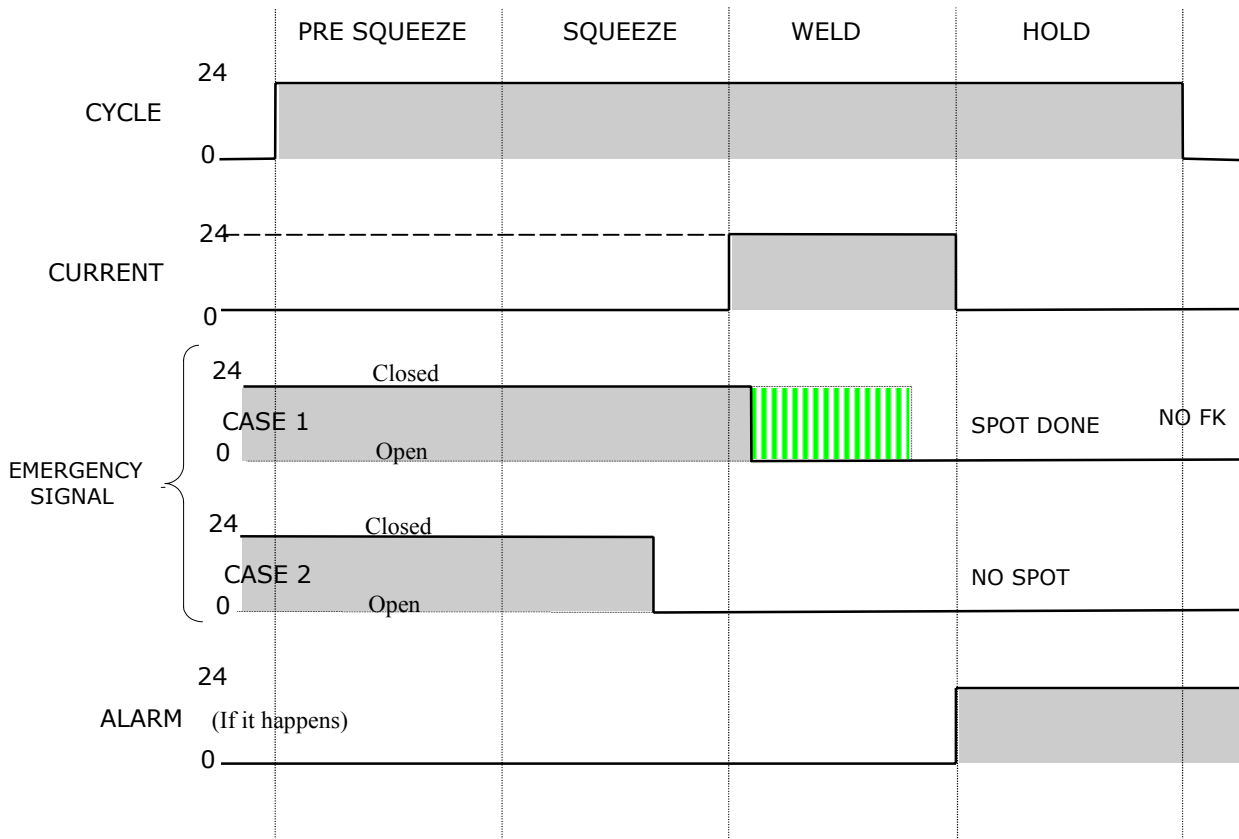

During emergency time-period situation the welding control behaviour will be:

- A started spot must be ended. In case of bad quality spot, with retry function programmed, all required retry-spots must be done
- If a quality spot alarm occurs it can be reset by PC or HHT
- NO dedicated message is generated/stored, to indicate the situation
- This situation is not to be considered an emergency but just a standard cycle operation, during that, all process have to be suspended

5 – EMERGENCY STOP excluded with START still active

NOTE: The Emergency stop signal is active at 0V

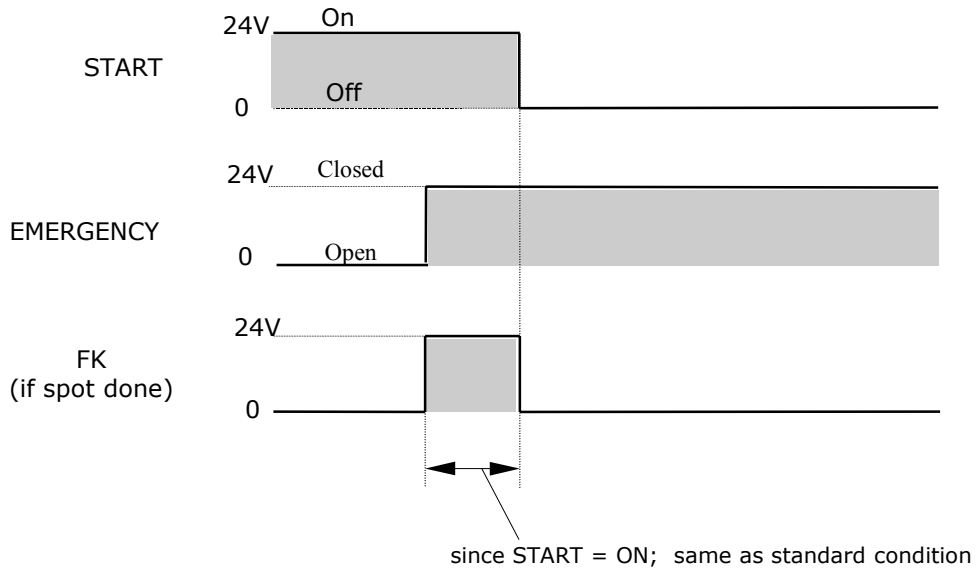

6 – START disabled condition during the welding pulse

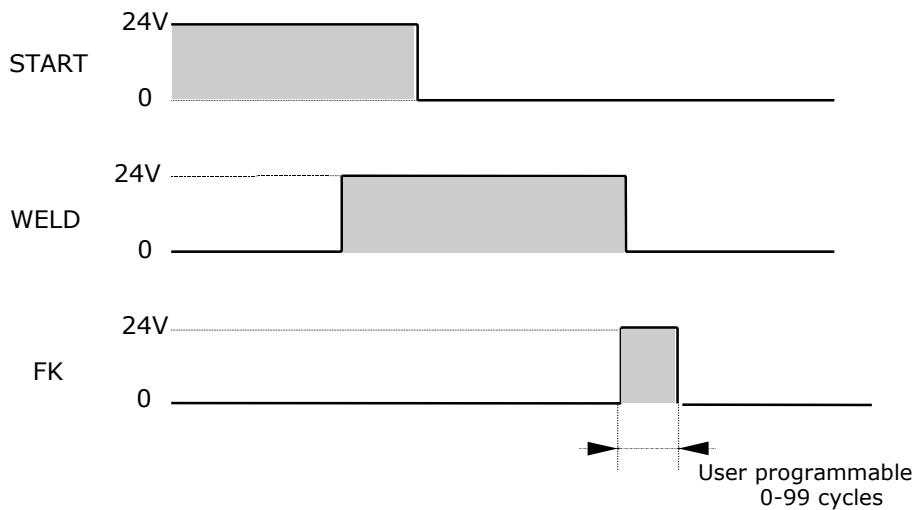

7 – Proportional Servo Valve operating diagram

Servo valve parameters description:

- OFFSET : 0 - 100 % (active only after a reset; until a start cycle) Stored in Setup function
- EV1 : 0 - 100 % Nominal value during welding cycle Stored in each program
- EV2 : 0 - 100 % Pressure variation value. Stored in each program

Change is done after n cycles; and in mode according the 5 available profiles

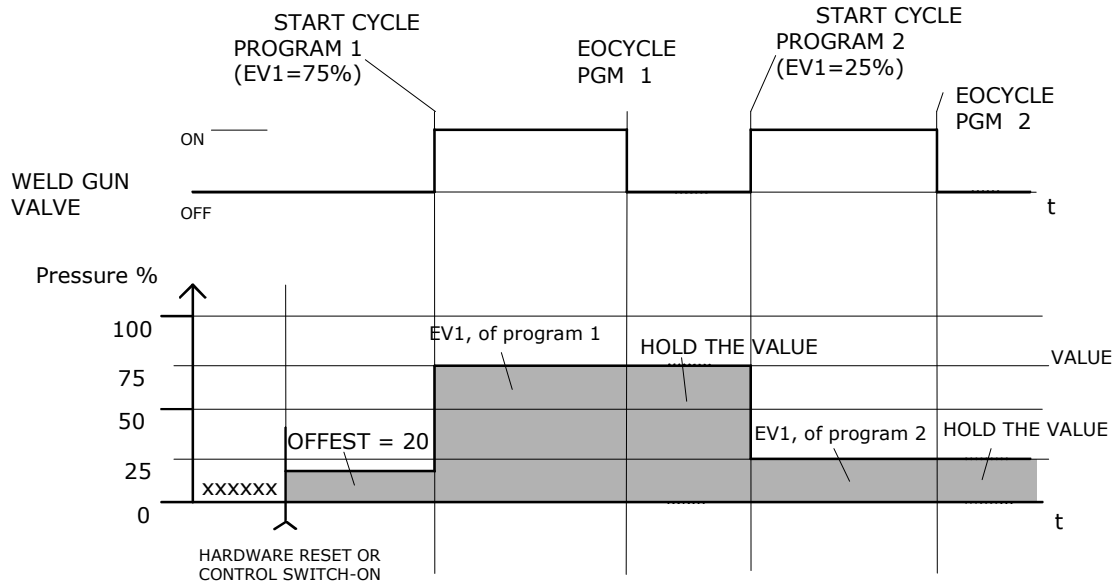

Pressure % = Output air pressure, percentage of input pressure.

Examples: with:	5 bar	input &	EV1 @	50 %;	servo valve output =	2,5
	"	"	"	75 %	"	= 3,75
	"	"	"	100 %	"	= 5 bar (servo valve drop not considered)

When the weld program code change (at the physical discrete inputs, or by serial line fieldbus as Interbus-S or Profibus DP or DeviceNet) immediately the servo valve command output will be updated according the EV1 value stored in the program choosed. Also without the Start signals. This function is always active.

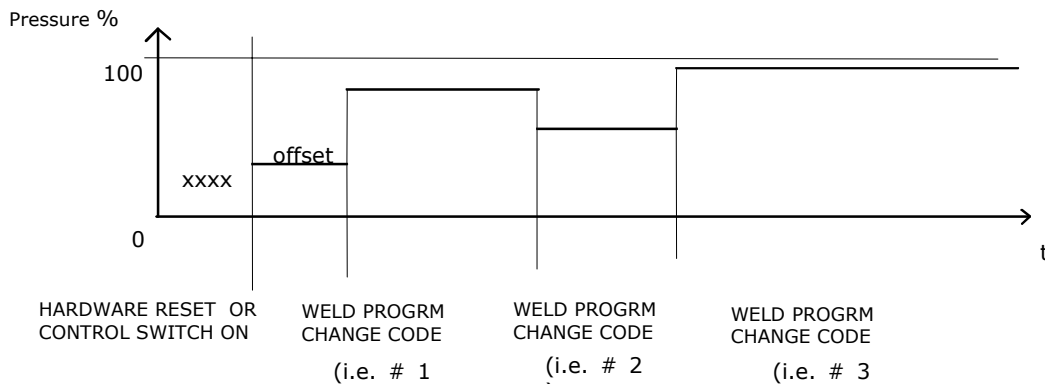

All changes without start cycle command

8 – ENABLE function (Interbus-s)

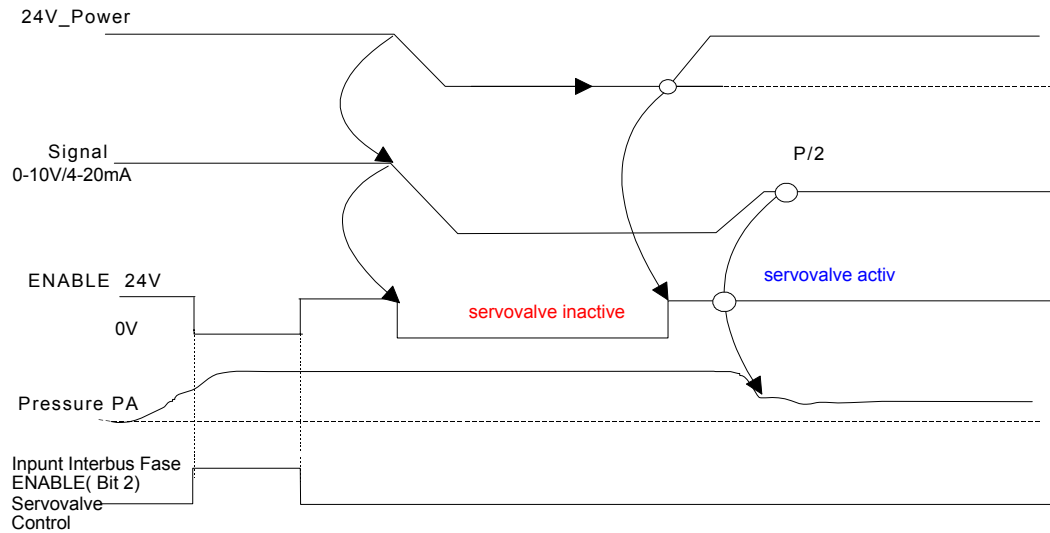

Signal behaviour:

ENABLE 24V: This function allows the valve control when voltage power supply interrupts (Fail save); the output current pressure is not modified.

Servovalve control Interbus input: This function allows the servovalve piloting to be done through the Interbus control input (Active High = ENABLE goes to 0V ->); pressure stays unchanged.

9 – Diagram of diagnostic pressure control

Mode of operation relates to the status of the programming parameter PROC / WAIT (see programming Manual, paragraph *Electrode Force Diagnostic Mode*)

Process in PROC mode

The control executes the sequence respecting the set timings. The diagnostic function signals any pressure errors.

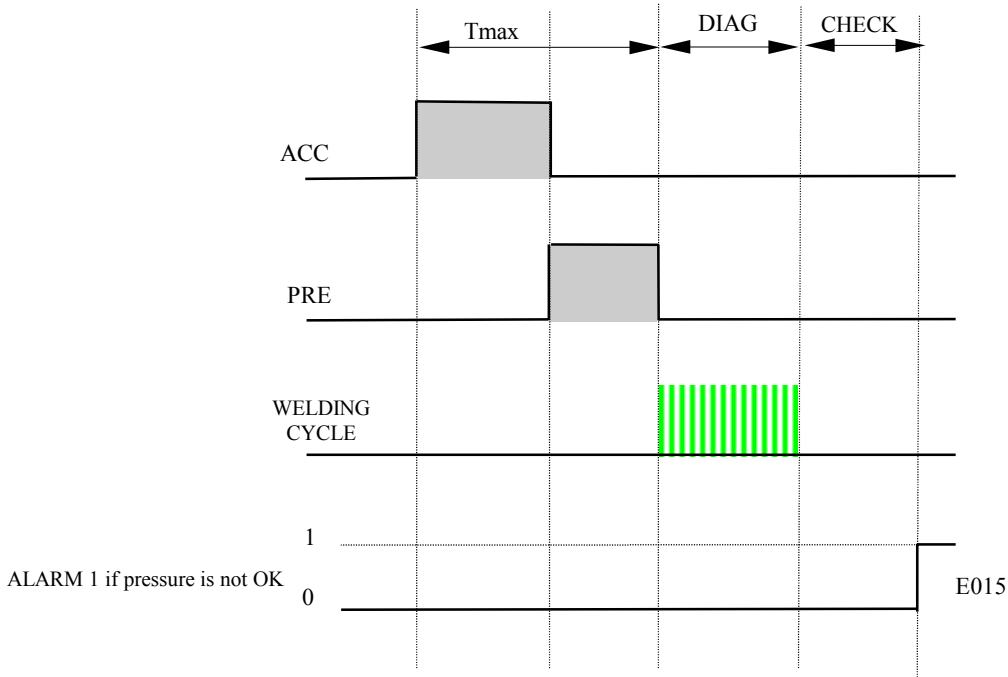

Process in WAIT mode

The welding pulse is only given when the nominal value P1 has been reached

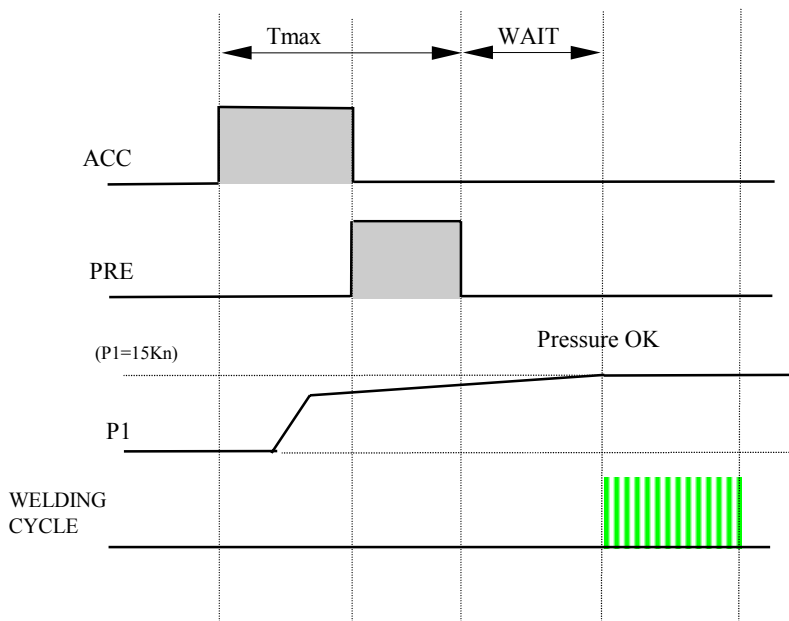

NOTE: When the parameter %T. Prs = 0 the function is disabled

Interbus-S –general architecture of I/O communications.

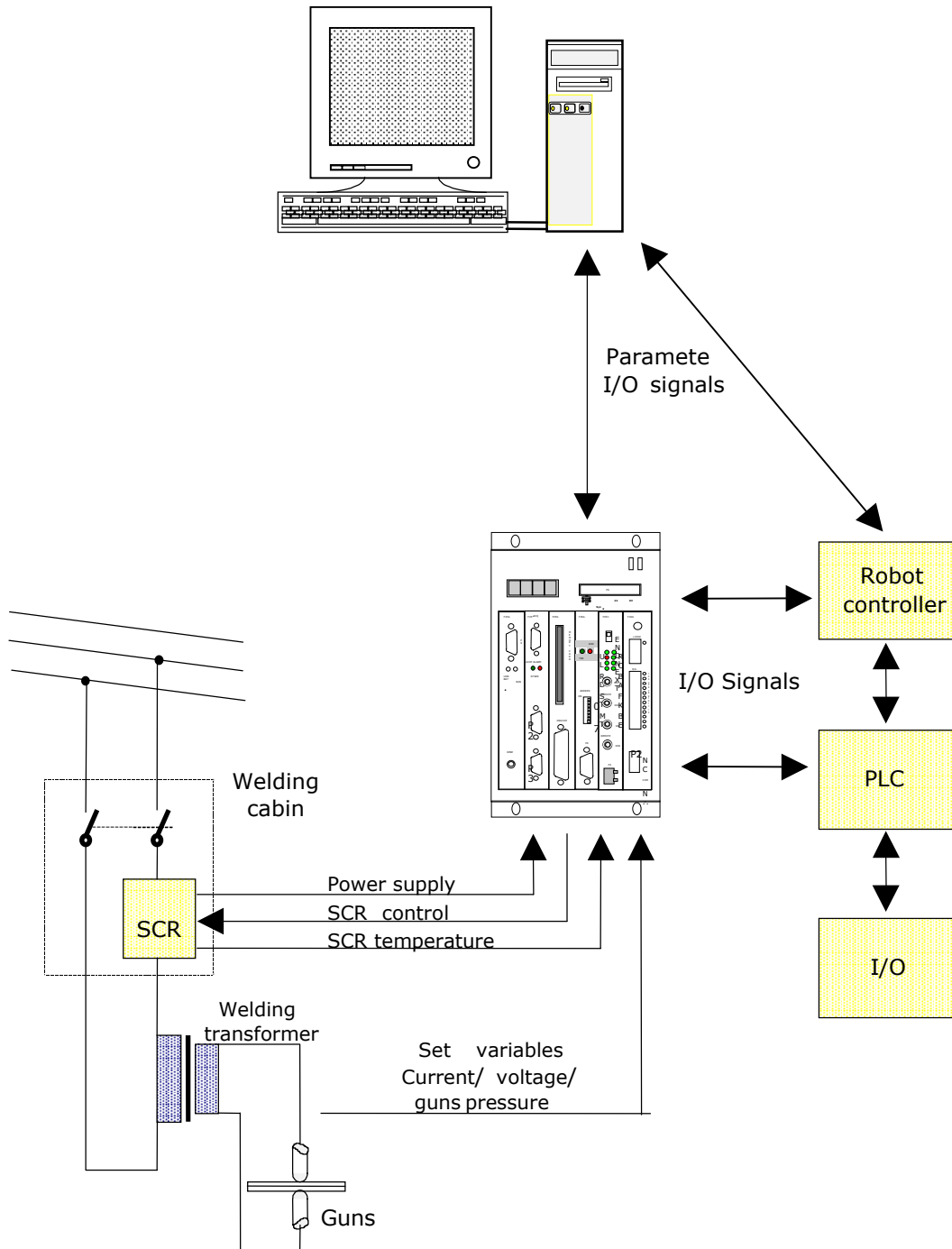

Ethernet Tcp/Ip – Example of network architecture

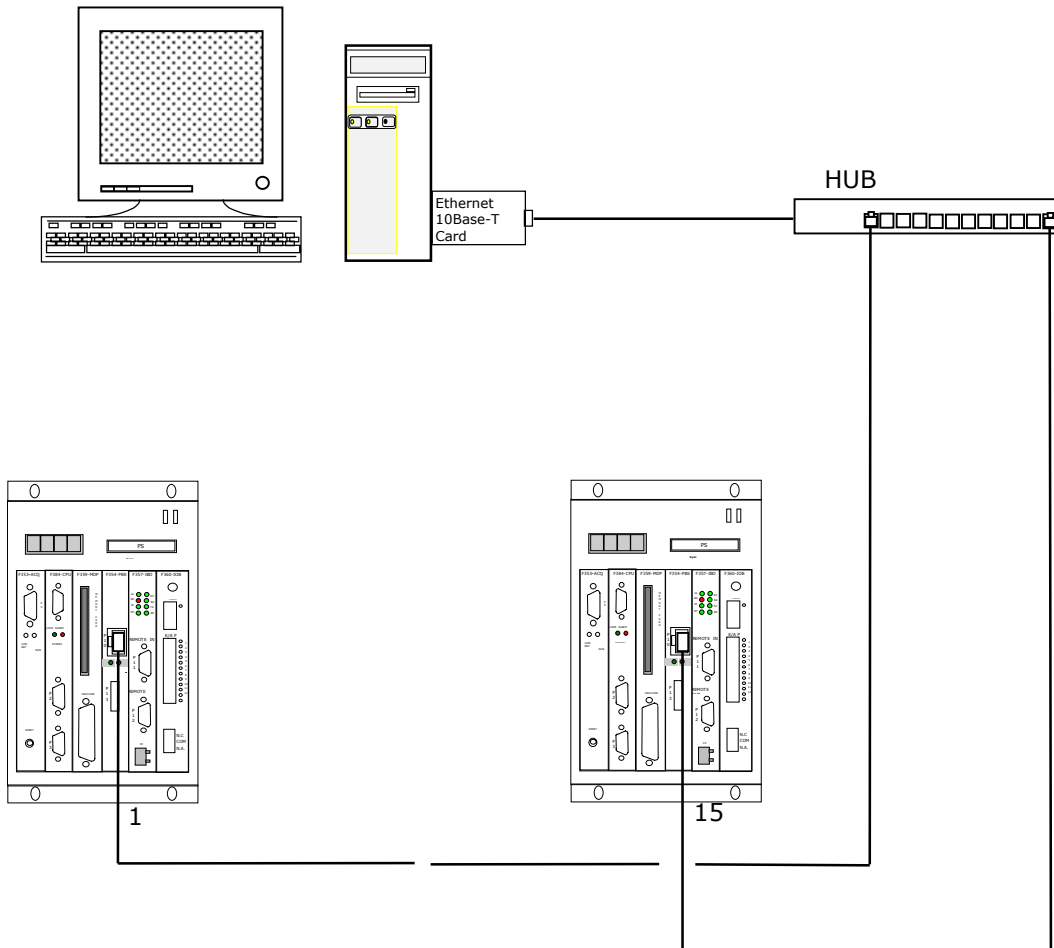

A maximum of 127 controls can be connected.
 Signal connection depends on the type of port present on the HUB, which can be of the MDI or of the MDI-X type.

InterBus-S- Example of network architecture

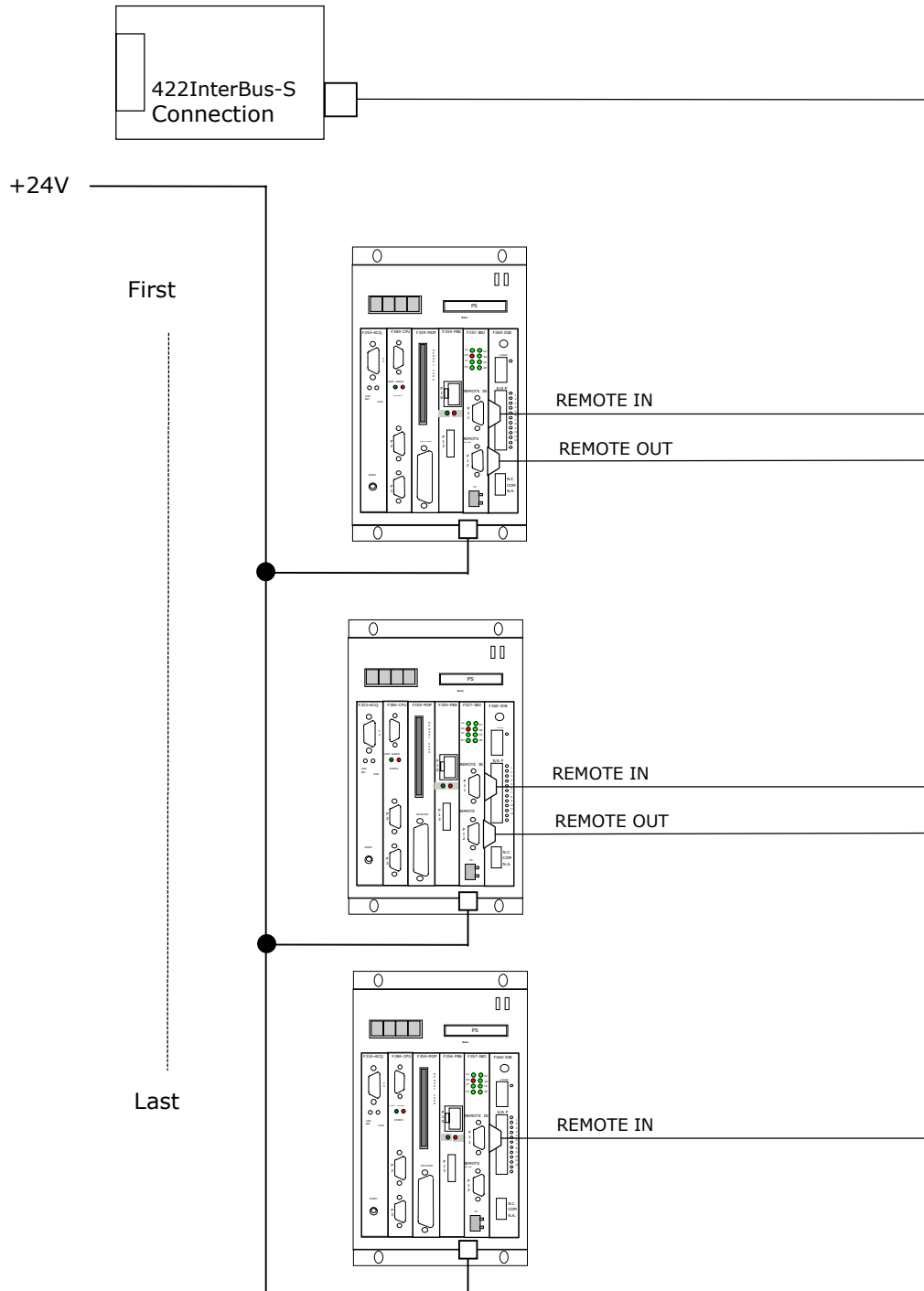

WHITE PAGE

APPENDIX C - Weld334m Application diagram

Dwg. 33033311/02
Dwg. 33033315/02
Dwg. 33033316/02

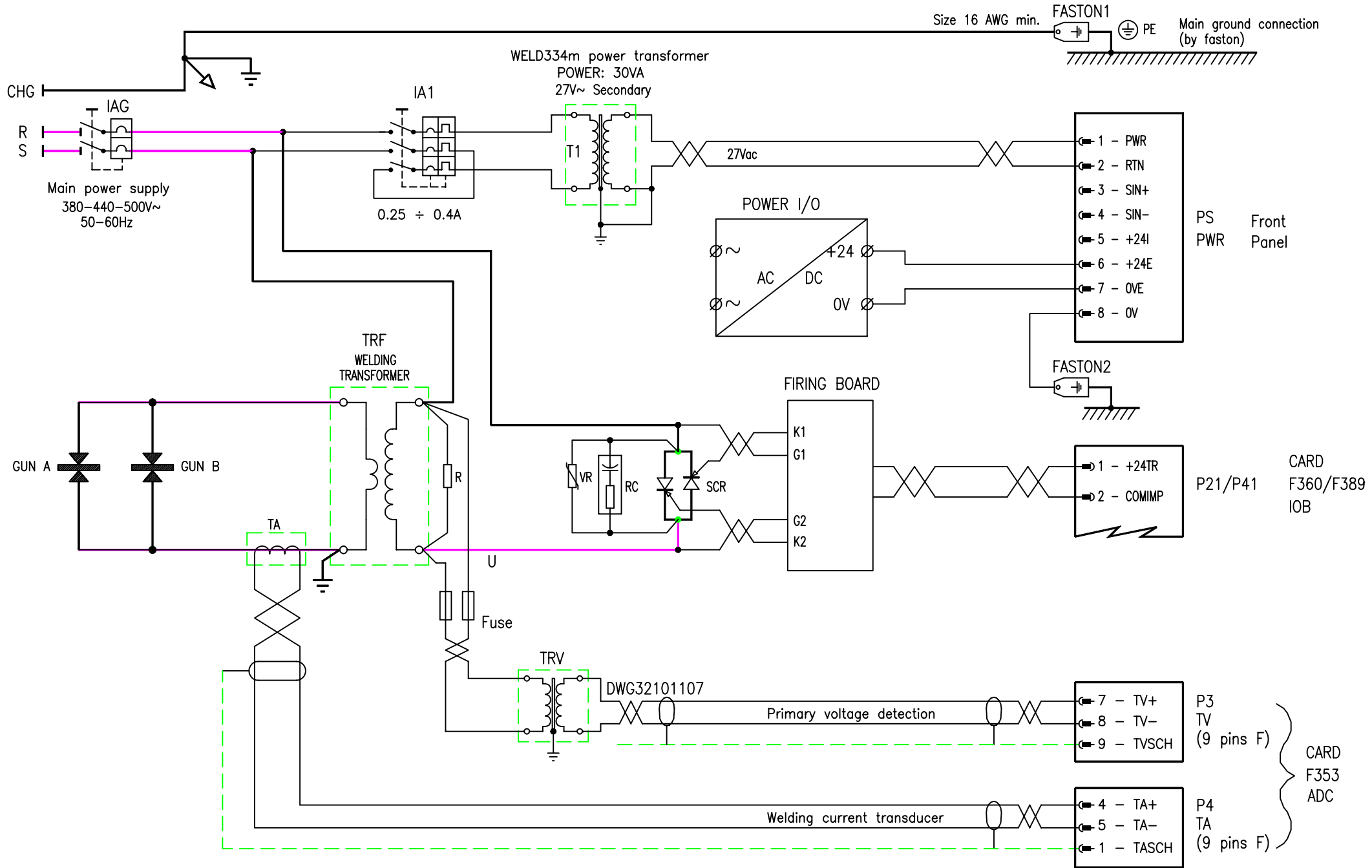

Part#	Qty.	Descr.	Mater.	Gen.#	Q.for gen.	Changement
		WELD334m Terminal block		Date 09/97	Scale	Code
		CONNECTIONS POWER 27V~ + 24Vdc,		Sheet n. 1	#of sheet 1	Author T.G.
		FIRING AND TRANSDUCERS		Draw n. 33033311/ 02		Fmt.

All proprietary rights reserved by Spa FASE. This drawing will not be reproduced or in any way utilized for the manufacture of the component or herein illustrated and must not be released to other parties without written consent. Any infringement will be legally pursued.

FASE
SALDATURA

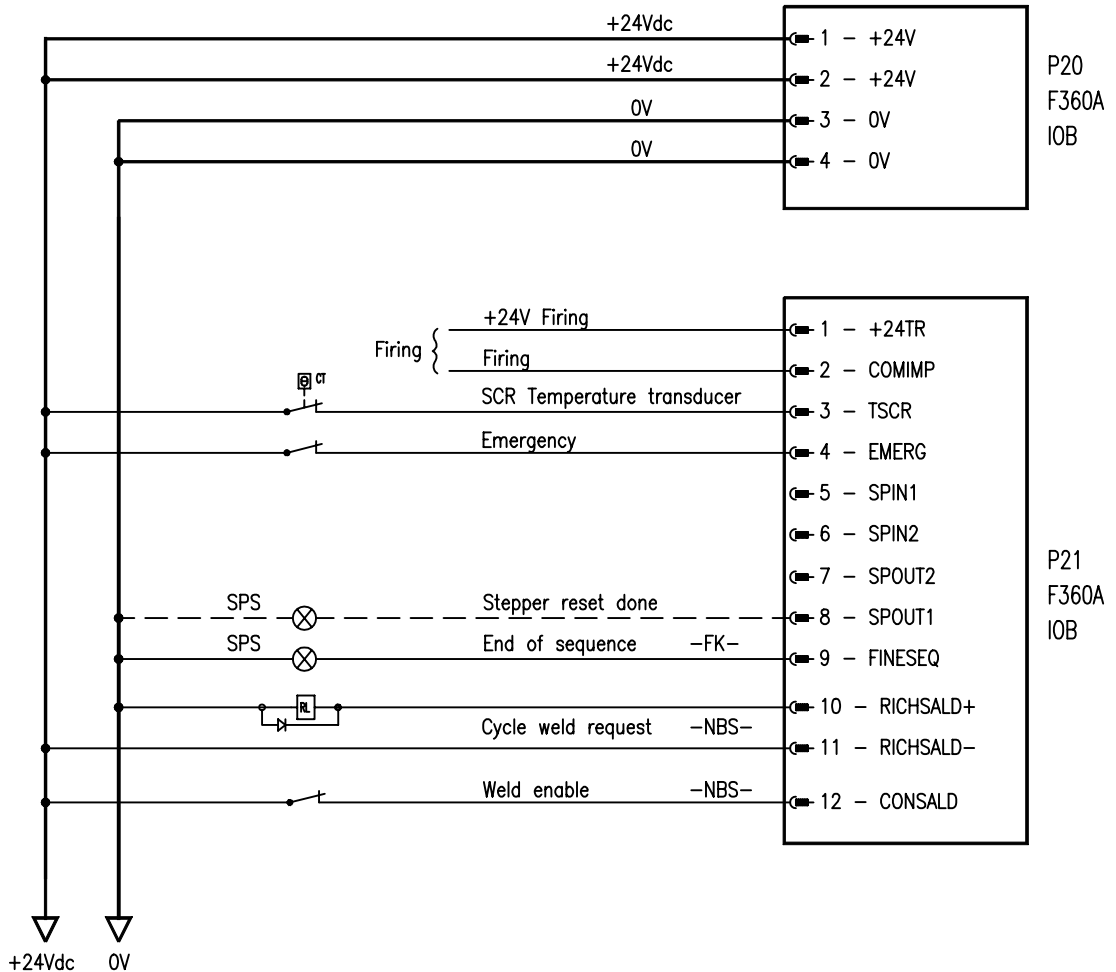
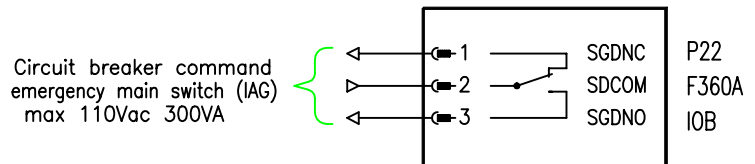
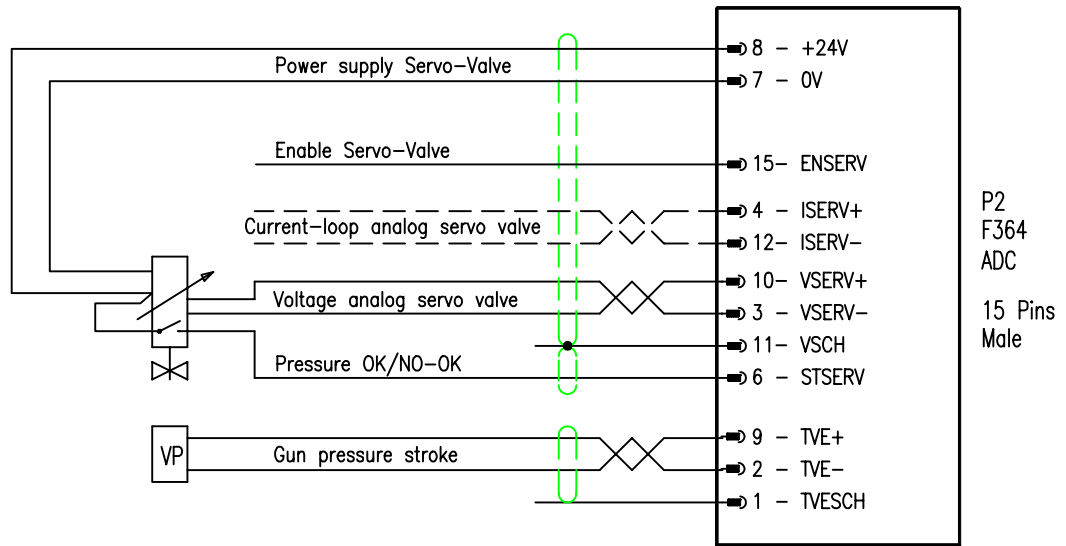

Part#	Qty.	Descr.	Mater.	Gen.#	Q.for gen.	Changement
WELD334m Terminal block				Date 02/98	Scale -	Code
CONNECTIONS CARD "F360A" IOB AND "F364" SERVO-VALVE				Sheet n. 1	#of sheet 1	Author T.G.
				Draw n. 33033315/02	Fmt.	-
<small>All proprietary rights reserved by Spa FASE. This drawing will not be reproduced or in any way utilized for the manufacture of the component or herein illustrated and must not be released to other parties without written consent. Any infringement will be legally pursued.</small>						

+24Vdc
From card F360 connector P3

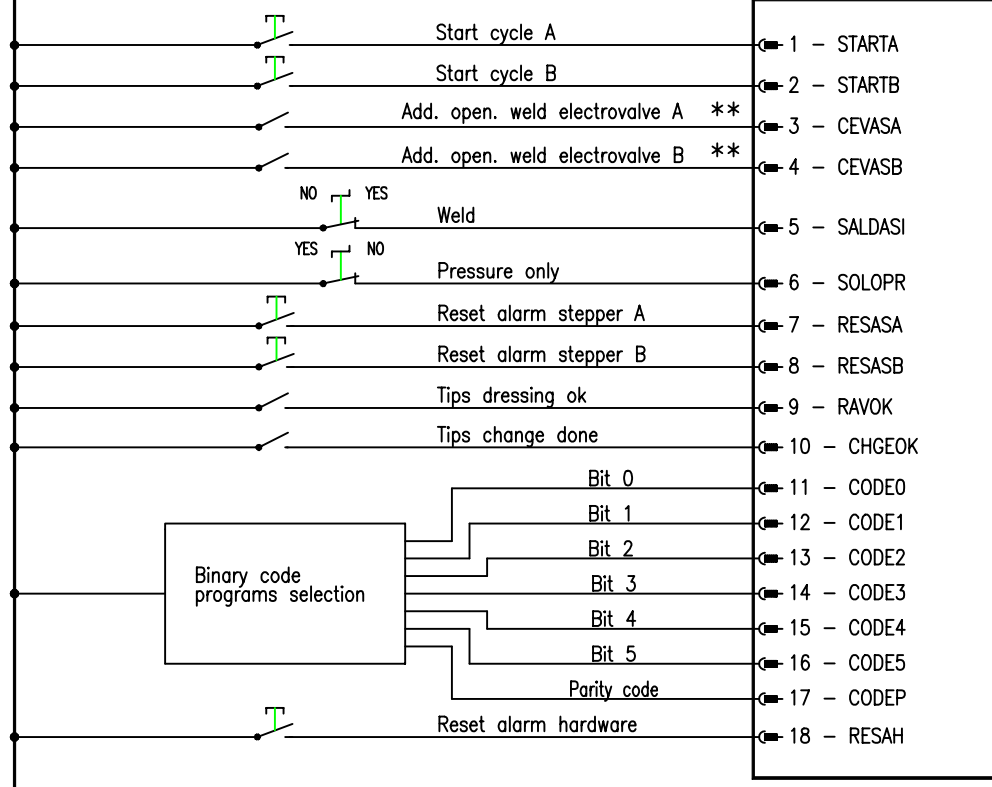

P24
F356A
IOE

SWITCH "SALDASI"		SWITCH "SOLOPR"		
YES (+24Vdc)	NO	NO (+24Vdc)	YES	
X		X		Weld
X			X	Pressure only
	X	X		No weld
	X		X	Pressure only

0V
From card F360 connector P3

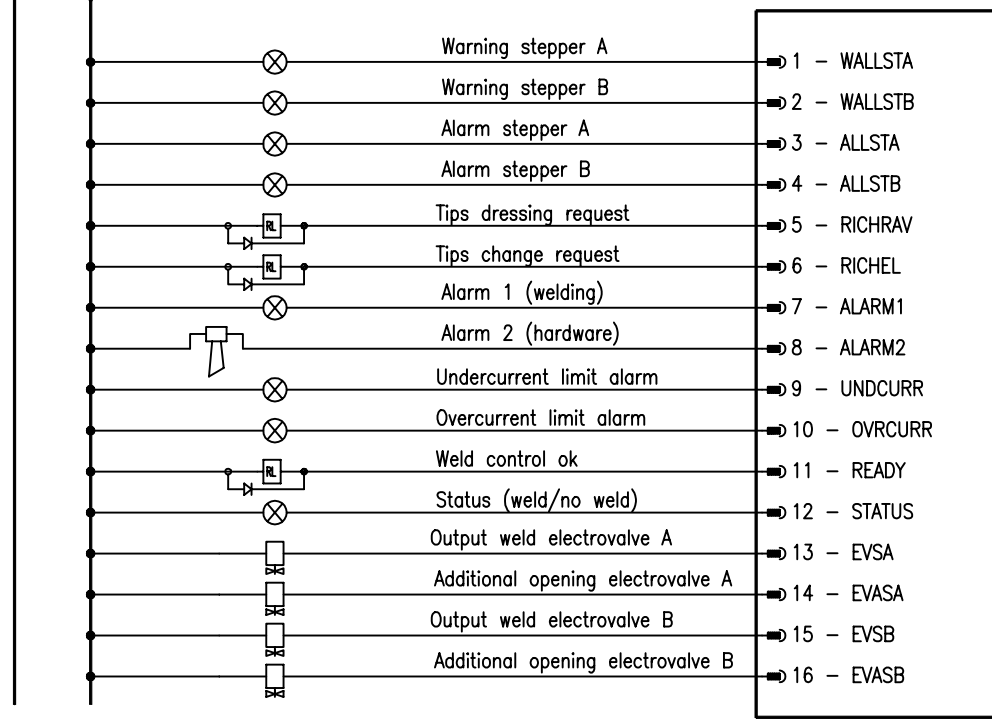

P23
F356A
IOE

** Short to +24Vdc when the functions are not utilized

Part#	Qty.	Descr.	Mater.	Gen.#	Q.for gen.	Changement
WELD334m Terminal block				Date 02/98	Scale -	Code
CONNECTIONS CARD "F356A" IOE				Sheet n. 1	#of sheet 1	Author T.G.
				Draw n. 33033316/02	Fmt.	-
<small>All proprietary rights reserved by Spa FASE. This drawing will not be reproduced or in any way utilized for the manufacture of the component or herein illustrated and must not be released to other parties without written consent. Any infringement will be legally pursued.</small>						