



USER MANUAL UMAX020502

QUAD CONTROLLER

With CANopen®

USER MANUAL

P/N: AX020502

In Europe:
Axiomatic Technologies Oy
Höytämöntie 6
33880 LEMPÄÄLÄ - Finland
Tel. +358 3 3595 600
Fax. +358 3 3595 660
www.axiomatic.fi

In North America:
Axiomatic Technologies Corporation
5915 Wallace Street
Mississauga, ON Canada L4Z 1Z8
Tel. 1 905 602 9270
Fax. 1 905 602 9279
www.axiomatic.com

VERSION HISTORY

Version	Date	Author	Modifications
1.00	March 6, 2006	Anna Murray	Initial Draft
1.01	March 17, 2006	Anna Murray	Changed PDO mappings from Optional to Yes Fixed Digital Output Bitmap Fixed a variety of typos
1.02	March 21, 2006	Anna Murray	Fixed some more typos Added LSS Reference Added description for Object 1011h
1.03	March 23, 2006	Anna Murray	Added hardware information Added Analog Input sample rate Added PWM Input filtering description
1.04	March 24, 2006	Anna Murray	Fixed Analog Input Block diagram
1.05	July 20, 2010	Anna Murray	Updated footer on cover page. Updated reference to latest datasheet.
1.06	Dec. 9, 2010	Amanda Wilkins	Added Appendix A – Technical Specifications
2.00	January 07, 2011	Anna Murray	Added new object 5555h. Updated formatting

TABLE OF CONTENTS

1. GENERAL	5
1.1. Axiomatic Quad Controller	5
1.2. Pinout	6
1.3. References	7
2. USING QUAD THROUGH CANOPEN	8
2.1. Node ID and Baudrate	8
2.2. Digital Inputs	8
2.3. Analog Inputs	9
2.4. Pulse Inputs	10
2.5. Digital Outputs	11
2.6. Proportional Outputs	12
3. OBJECT DICTIONARY	14
3.1. COMMUNICATION OBJECTS	14
3.1.1. PDO Parameters	15
3.1.2. Object 1000h: Device Type	17
3.1.3. Object 1001h: Error Register	17
3.1.4. Object 1003h: Pre-Defined Error Field	18
3.1.5. Object 1010h: Store Parameters	19
3.1.6. Object 1011h: Restore Default Parameters	20
3.1.7. Object 1016h: Consumer Heartbeat Time	21
3.1.8. Object 1018h: Identity Object	22
3.1.9. Object 1029h: Error Behaviour	23
3.1.10. Object 5555h: Start in Operational	24
3.2. DIGITAL INPUT FUNCTION BLOCK (DS-404)	25
3.2.1. Object 2000h: DI Level 8 Input Lines	25
3.2.2. Object 2001h: DI Low Threshold	26
3.2.3. Object 2002h: DI High Threshold	27
3.2.4. Object 6000h: DI Read State 8 Input Lines	28
3.2.5. Object 6002h: DI Polarity 8 Input Lines	28
3.3. ANALOG INPUT FUNCTION BLOCK (DS-404)	29
3.3.1. Object 2010h: AI Error Minimum	29
3.3.2. Object 2020h: AI Minimum	30
3.3.3. Object 2030h: AI Breakpoint Minimum	31
3.3.4. Object 2040h: AI Deadband Minimum	31
3.3.5. Object 2050h: AI Deadband Maximum	32
3.3.6. Object 2060h: AI Breakpoint Maximum	33
3.3.7. Object 2070h: AI Maximum	33
3.3.8. Object 2080h: AI Error Maximum	34
3.3.9. Object 2090h: AI Frequency Measuring Window	35
3.3.10. Object 20A0h: AI Enable Error Checking 8 Input Lines	35
3.3.11. Object 20B0h: AI Error Response Delay	36
3.3.12. Object 7100h: AI Input Field Value	37
3.3.13. Object 6110h: AI Sensor Type	38
3.3.14. Object 6112h: AI Operating Mode	39
3.3.15. Object 7120h: AI Input Scaling 1 FV	40
3.3.16. Object 7121h: AI Input Scaling 1 PV	40

3.3.17.	Object 7122h: AI Input Scaling 2 FV.....	41
3.3.18.	Object 7123h: AI Input Scaling 2 PV.....	41
3.3.19.	Object 7124h: AI Input Offset.....	42
3.3.20.	Object 6125h: AI Autozero.....	42
3.3.21.	Object 7130h: AI Input Process Value.....	43
3.3.22.	Object 6132h: AI Decimal Digits PV.....	43
3.3.23.	Object 61A0h: AI Filter Type.....	44
3.3.24.	Object 61A1h: AI Filter Constant.....	45
3.4.	DIGITAL OUTPUT FUNCTION BLOCK (DS-404).....	46
3.4.1.	Object 3001h: DO Control Input.....	46
3.4.2.	Object 3002h: DO Response 8 Output Lines.....	47
3.4.3.	Object 300Bh: DO Error Response Delay.....	48
3.4.4.	Object 300Ch: DO Read State 8 Output Lines.....	48
3.4.5.	Object 6200h: DO Write State 8 Output Lines.....	49
3.4.6.	Object 6202h: DO Polarity 8 Output Lines.....	50
3.4.7.	Object 6206h: DO Fault Mode 8 Output Lines.....	50
3.4.8.	Object 6207h: DO Fault State 8 Output Lines.....	51
3.5.	ANALOG OUTPUT FUNCTION BLOCK (DS-404).....	52
3.5.1.	Object 3010h: AO Control Input.....	52
3.5.2.	Object 3020h: AO Response.....	53
3.5.3.	Object 3030h: AO Minimum Current.....	54
3.5.4.	Object 3040h: AO Breakpoint Current.....	55
3.5.5.	Object 3050h: AO Maximum Current.....	55
3.5.6.	Object 3060h: AO Dither Frequency.....	56
3.5.7.	Object 3070h: AO Dither Amplitude.....	56
3.5.8.	Object 3080h: AO Ramp Up.....	57
3.5.9.	Object 3090h: AO Ramp Down.....	57
3.5.10.	Object 30A0h: AO Ramp Control.....	58
3.5.11.	Object 30B0h: AO Error Response Delay.....	58
3.5.12.	Object 30C0h: AO Measured Current.....	59
3.5.13.	Object 7300h: AO Output Process Value.....	60
3.5.14.	Object 6302h: AO Decimal Digits PV.....	60
3.5.15.	Object 6310h: AO Output Type.....	61
3.5.16.	Object 7320h: AO Output Scaling 1 PV.....	62
3.5.17.	Object 7321h: AO Output Scaling 1 FV.....	62
3.5.18.	Object 7322h: AO Output Scaling 2 PV.....	63
3.5.19.	Object 7323h: AO Output Scaling 2 FV.....	63
3.5.20.	Object 7330h: AO Output Field Value.....	64
3.5.21.	Object 6340h: AO Fault Mode.....	64
3.5.22.	Object 7341h: AO Fault FV.....	65
3.5.23.	Object 7F50h: Received PV 16.....	65
3.5.24.	Object 6F52h: Received PV Status.....	66
4.	ERROR HANDLING.....	67
4.1.	Emergency Frame Codes (EMCY).....	67
4.2.	Quad Fault Mode Behaviour.....	68
APPENDIX A – TECHNICAL SPECIFICATIONS.....		A

1. GENERAL

1.1. Axiomatic Quad Controller

The Axiomatic Quad Controller is a CANopen compliant [DS-301] I/O module with a configurable selection of I/O types. The Quad object dictionary is compatible with the CiA DS-404 device profile. (Device profile for measurement devices and closed-loop controllers.) In addition to the standard objects for this device profile, the Quad also includes a number of manufacturer specific objects to extend the functionality beyond that of the basic profile.

The module includes the following I/O:

- Four (4) software configurable analog inputs that can be configured as voltage [0-5V] or [0-10V], current [0-20mA] or [4-20mA], or ON/OFF input with programmable threshold levels, or active high/low digital input. **Named AIN1 to AIN4**
- Two (2) software configurable pulse inputs that can be configured as PWM [0-100% duty cycle], or frequency [0-10,000Hz] or ON/OFF input with programmable threshold levels, or active high/low digital input. **Named FIN1 to FIN2**
- Four (4) proportional outputs that can be software configured for either closed-loop current control or digital outputs. Maximum is 2A/channel, sourcing. **Named POUT1 to POUT4**
- One (1) ON/OFF output for up to 5A load, sourcing. **Named DOUT**

Note: Total current consumption of all the outputs combined must not exceed 6A.

A convenient feature of the CANopen Quad is the ability to map any input on the board as the control signal for any output. This feature is described in greater detail in section 2.

Refer to datasheet **TDAX020502** for full electrical specifications of the inputs and outputs.

1.2. Pinout

HOUSING DIMENSIONS

Housing Material: High Temperature Nylon (Black)

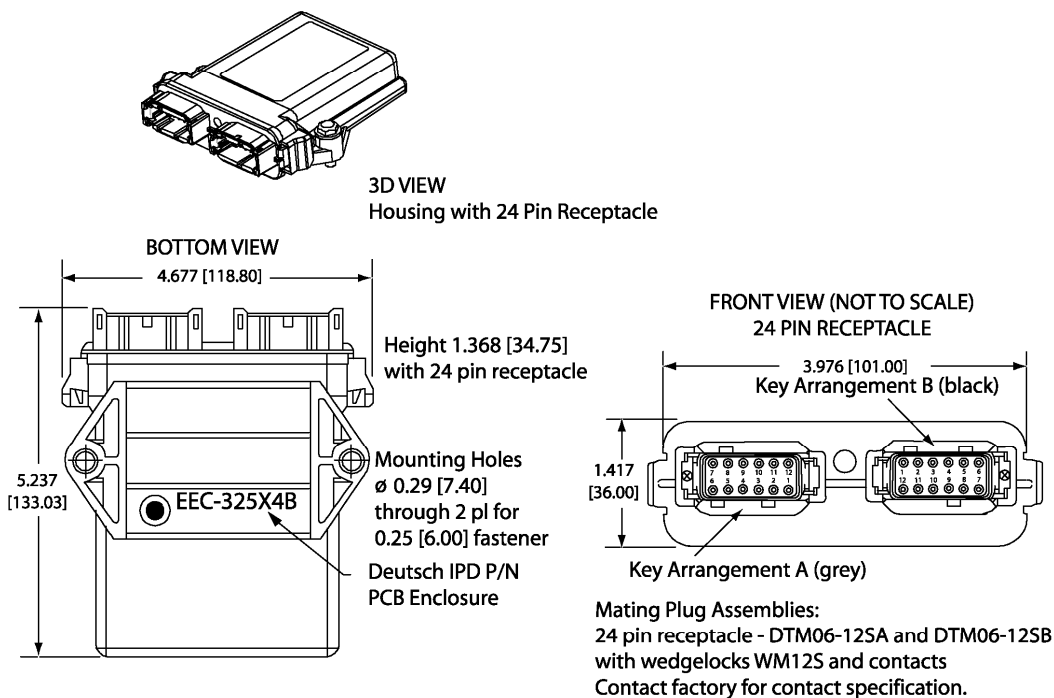

Dimensions: inches [mm]
excluding mating plug(s)

Deutsch Connector Pinout

Grey Connector		Black Connector	
Pin #	Function	Pin #	Function
1	Power +	1	CANH
12	Power -	2	CANL
2	Proportional Solenoid 1 + (POUT1)	3	Analog Input 1/Digital Input 1 (AIN1/DIN1)
11	Proportional Solenoid 1 -	4	Analog Input 2/Digital Input 2 (AIN2/DIN2)
3	Proportional Solenoid 2 + (POUT2)	5	Analog Input 3/Digital Input 3 (AIN3/DIN3)
10	Proportional Solenoid 2 -	6	Analog Input 4/Digital Input 4 (AIN4/DIN4)
4	Proportional Solenoid 3 + (POUT3)	7	RS-232 Transmit
9	Proportional Solenoid 3 -	8	RS-232 Receive
5	Proportional Solenoid 4 + (POUT4)	9	Analog GND (could be used as RS-232 GND)
8	Proportional Solenoid 4 -	10	Analog +5V Reference, 10mA
6	Digital Solenoid + (DOU)	11	Pulse Input 1/Digital Input 5 (FIN1/DIN5)
7	Digital Solenoid -	12	Pulse Input 2/Digital Input 6 (FIN2/DIN6)

Note: An analog input can be configured for 0-5V, 0-10V, 0-20mA or 4-20mA input types

Connector to DB-9 Pinout (RS-232 Connection)

Black Deutsch Connector		DB-9 Female	
Pin #	Controller Function	Pin #	PC Function
7	RS-232 Transmit	2	RS-232 Receive
8	RS-232 Receive	3	RS-232 Transmit
9	GND	5	GND

1.3. References

- [DS-301] CiA DS-301 V4.02 – CANopen Application Layer and Communication Profile. CAN in Automation 2002
- [DS-404] CiA DS-404 V1.2 – Device Profile for Measurement Devices and Closed-Loop Controllers. CAN in Automation 2002
- [DS-305] CiA DS-305 V2.0 – Layer Setting Service (LSS) and Protocols. CAN in Automation 2006
- LSS Protocol, User’s Manual V1.2. Axiomatic Technologies 2004
- TDAX020502 Technical Datasheet, CANopen Quad. Axiomatic Technologies 2010

2. USING QUAD THROUGH CANOPEN

2.1. Node ID and Baudrate

The Quad supports the Layer Setting Service (LSS) protocols to configure the node-id and baudrate. Refer to the document “LSS Protocol” for more details.

2.2. Digital Inputs

The digital input function block handles the reading of any input pin configured as either a digital input, or an ON/OFF input with programmable threshold levels. Note, however, the analog input operating mode is set through the object 6112h, in the analog input function block. For inputs that are NOT configured as digital or ON/OFF, the objects associated with the digital input block are ignored.

A manufacturer specific object 2000h has been introduced for setting the digital input active level. On the Quad, the digital input pins have a software-configurable hardware polarity, so the inputs can act as either active high or active low inputs. The application object 6002h also allows the input polarity to be changed in software. The combination of the hardware level and software polarity allows the digital inputs to work with any wiring scheme, and they are capable of acting as either as an enable (on when switch is closed) or disable (off when switch is closed) signal.

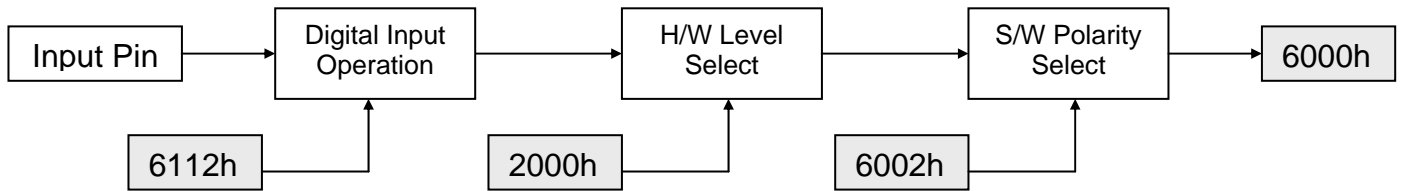

If configured as an ON/OFF input with programmable threshold levels, the manufacturer specific objects 2001h and 2002h are used to determine the ON/OFF state. If the input measured is less than or equal to object 2001h [low threshold] the input is off. If greater than or equal to object 2002h [high threshold] (when 2001h not equal 2002h) the input is on. If the measured value is between the two thresholds, the input does not change state from the last reading. In this case, the object 6002h is ignored.

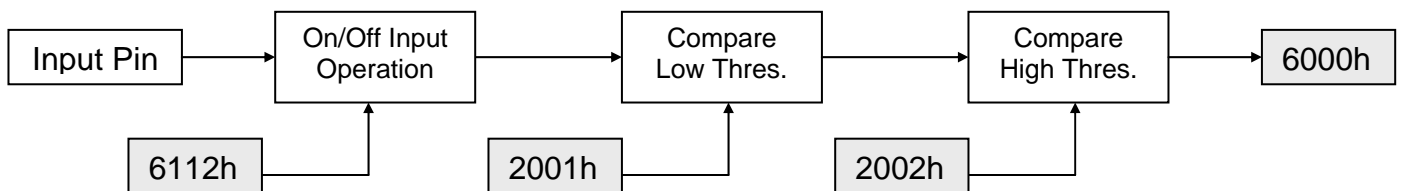

For objects corresponding to 8 digital input lines on the controller, the bit order is as shown.

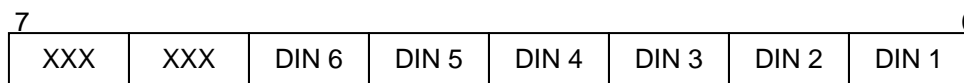

2.3. Analog Inputs

The analog input function block handles the reading of any input configured as an analog input by the object 6112h. The type of input is determined by object 6110h, and can be set to one of the following four modes. Note, if the operation of the input has been configured as ON/OFF with programmable threshold levels, object 6110h also applies. Analog inputs are sampled every 10ms.

- Voltage input, range 0-5V
- Voltage input, range 0-10V
- Current input, range 0-20mA
- Current input, range 4-20mA

The conversion from input field value to process value is generally described as a linear transformation. The two pairs of field values and their corresponding process values define calibration points 1 and 2. (Input Scaling 1 FV/ Input Scaling 1 PV and Input Scaling 2 FV/ Input Scaling 2 PV) See DS-404 for more information.

If error checking on an input is enabled by object 20A0h, then the controller will compare the measured field value to the values in objects 2010h [Error Minimum] and 2080h [Error Maximum]. If less than 2010h, or greater than 2080h, the controller will flag an error after the delay time in object 20B0h has passed. (See section 4 for more details on emergency objects, and the controller's response to errors.)

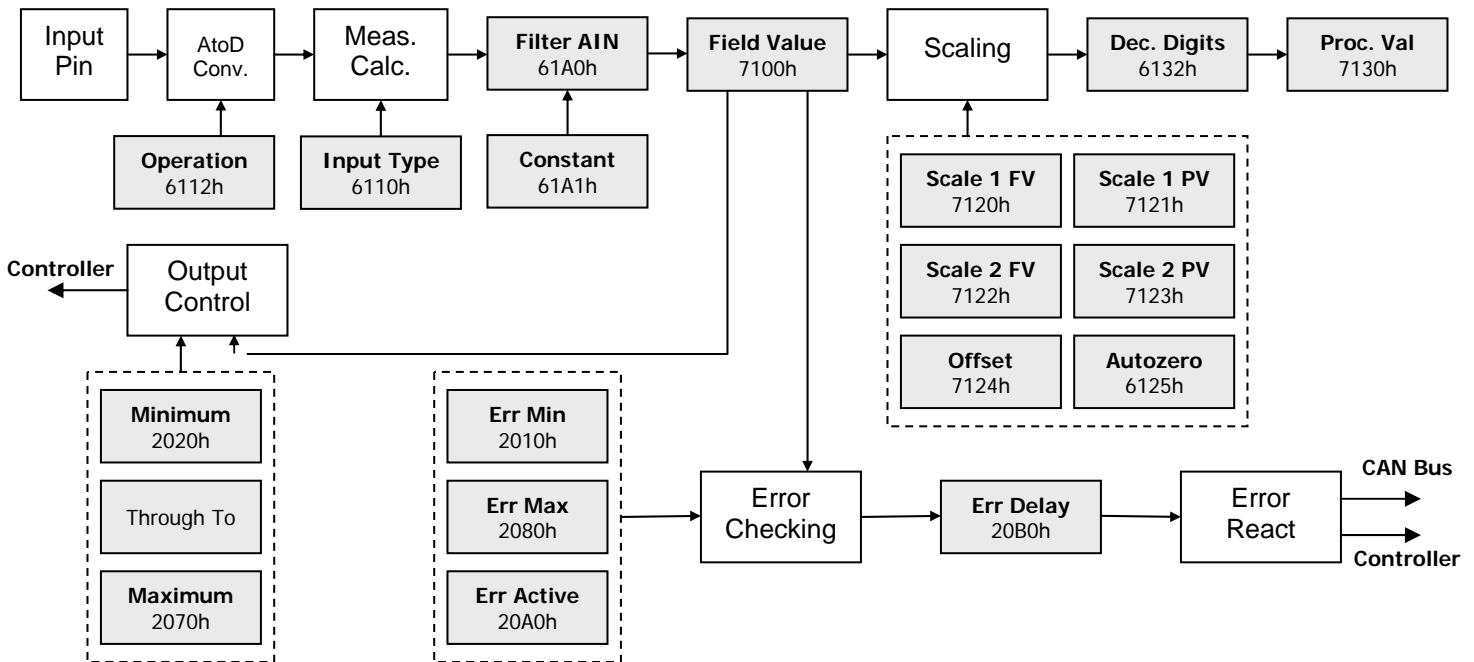

Since the analog inputs can be used to control any of the outputs on the quad, independent of CANopen, there are a number of manufacturer parameters that will determine how the output responds to a change at the inputs. If an output control signal has been set to one of the analog inputs, it uses the input field value as the control input. See sections 2.4 and 2.5 for more details.

For objects corresponding to 8 analog input lines on the controller, the bit order is as shown.

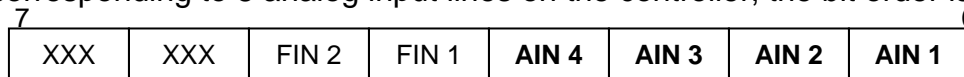

2.5. Digital Outputs

The digital output function block handles the control of the digital output on the quad, as well as any off the proportional outputs that have been configured as a digital output. Note that for proportional outputs, the digital output operating mode is set through the object 6310h, in the analog output function block.

All digital outputs can be controlled by either a digital or ON/OFF input on the controller, or by writes to object 6200h (DO Write States), but not both methods at once. Manufacturer object 3001h dictates the control signal for the output. Since an output can be controlled independent of object 6200h, a manufacturer object 300Ch has been introduced to show the read states of the digital outputs as a means of indicating states to the bus at any time.

Object 6202h sets the polarity of the output, determining if the output will be on (normal) or off (inverted) when control input is on. Manufacturer object 3002h determines if the output will have a standard on/off response to the control input, or if it will have a latched response. In latched mode, object 6202h is ignored, and when the input comes on, the output will come on, and stay on. When the input comes on again (after having been off), the output will turn off, and stay off until the output comes on again, repeating the cycle.

If an error is detected on the output, the controller will flag an error after the delay time in object 300Bh has passed. Objects 6206h (DO fault mode) and objects 6207h (DO fault state) apply to any output configured as a digital output. Refer to Section 4 for a detailed description of a digital output's response to an error.

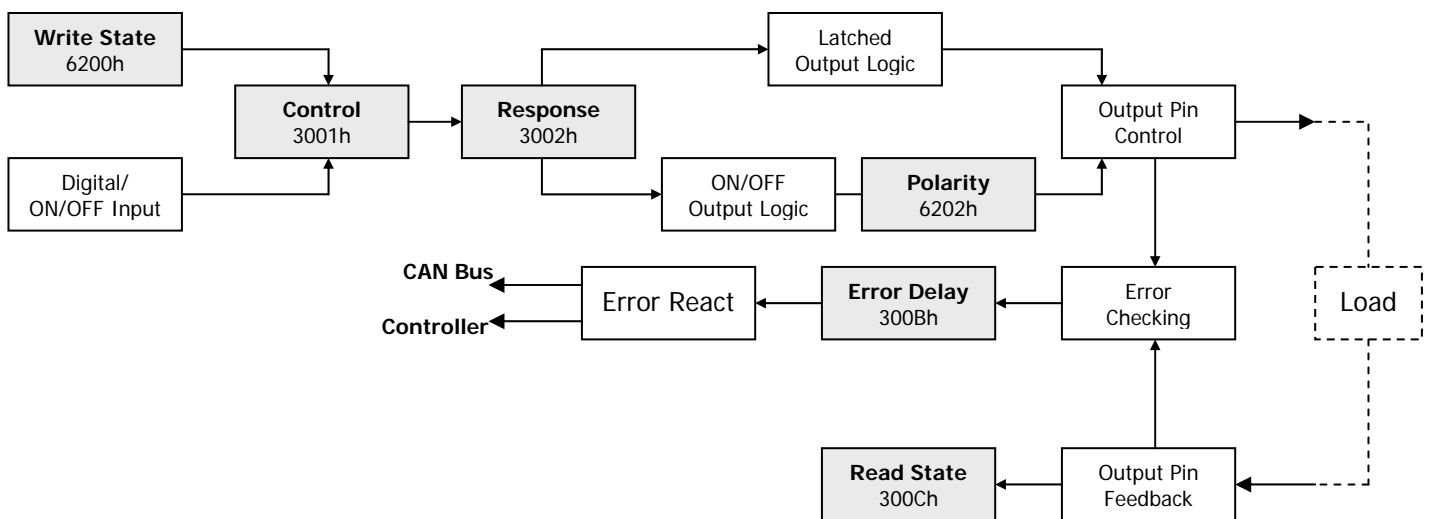

For objects corresponding to 8 digital output lines on the controller, the bit order is as shown.

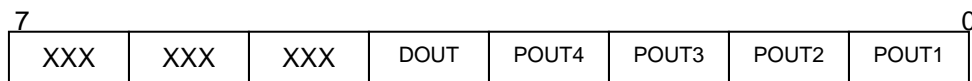

2.6. Proportional Outputs

The analog output function block handles the control of the proportional outputs on the quad that have been configured for current output by object 6310h.

All proportional outputs can be controlled by either an analog or pulse input on the controller, or by writes to object 7330h (AO Field Value)/object 7F50h (Received PV), but not both methods at once. Manufacturer object 3010h dictates the control signal for the output. Since an output can be controlled independent of object 7330h, a manufacturer object 30C0h has been introduced as a means of indicating the measured feedback current of the outputs to the bus at any time.

The object 7F50h can be mapped to a PDO to send a process value to the controller. In order for the controller to accept the received PV, the status of object 6F52h must be validated. The conversion from received process value to field value is generally described as a linear transformation. The two pairs of process values and their corresponding field values define calibration points 1 and 2. (Input Scaling 1 PV/ Input Scaling 1 FV and Input Scaling 2 PV/ Input Scaling 2 FV) See DS-404 for more information.

Some manufacturer objects have been introduced for the case where a proportional output is being controlled by an input on the Quad. These objects are 3020h (response), 3030h (minimum current), 3040h (breakpoint current), and 3050h (maximum current). The response of the output will be as shown in one of the graphs below, depending on the setting of object 3020h. If the output's control signal is a CANopen message (FV or PV), then these objects are ignored.

Manufacturer dither objects 3060h (frequency) and 3070h (amplitude) apply regardless of which control signal is selected. Ramp objects 3080h (up) and 3090h (down) can apply or not depending on the setting of object 30A0h (ramp control).

If an error is detected on the output, the controller will flag an error after the delay time in object 30B0h has passed. Objects 6340h (AO fault mode) and objects 7341h (AO fault FV) apply to any output configured as a current output. Refer to Section 4 for a detailed description of a proportional output's response to an error.

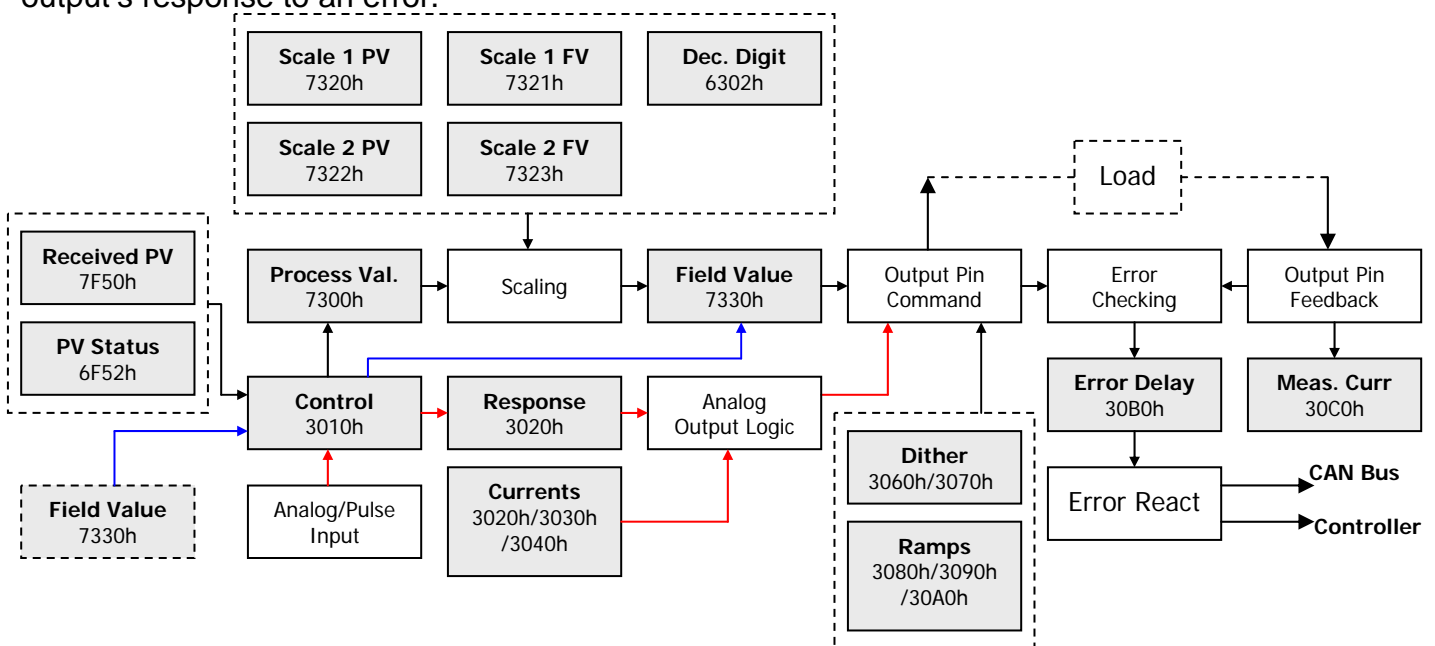

SINGLE PROFILE

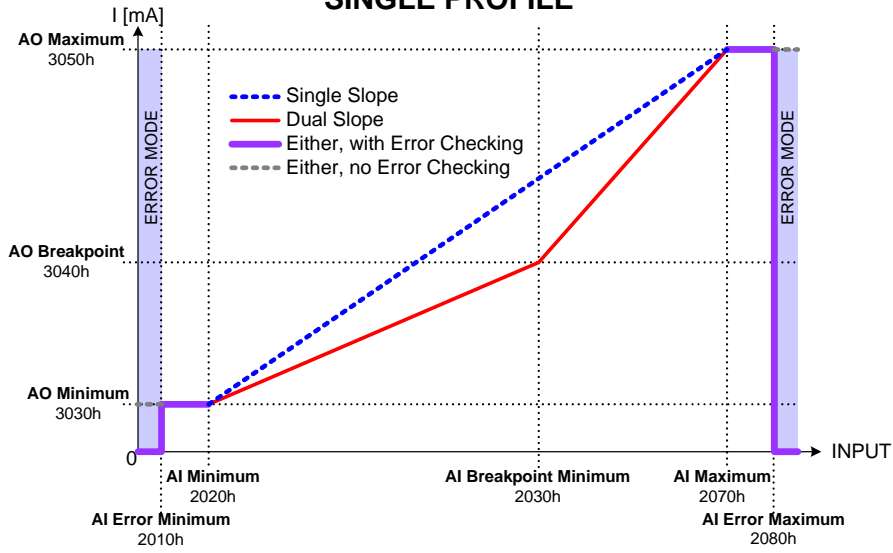

DUAL PROFILE A

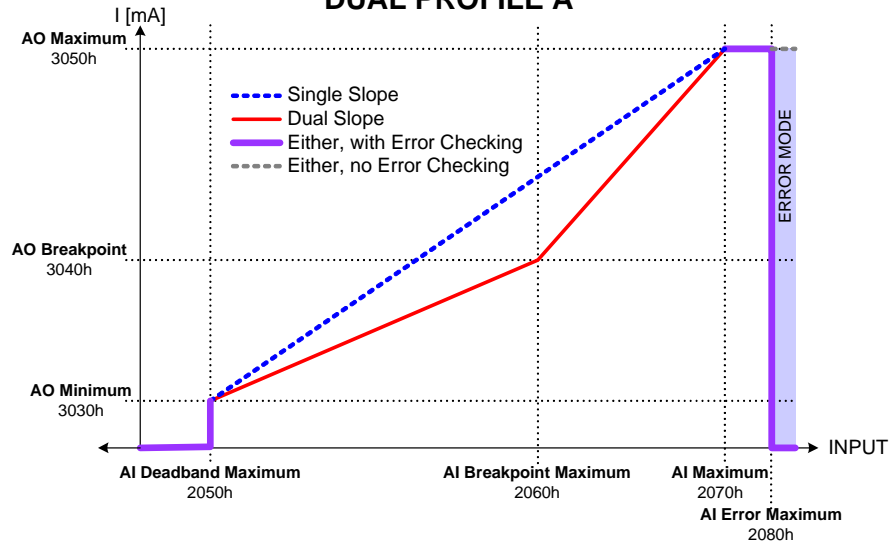

DUAL PROFILE B

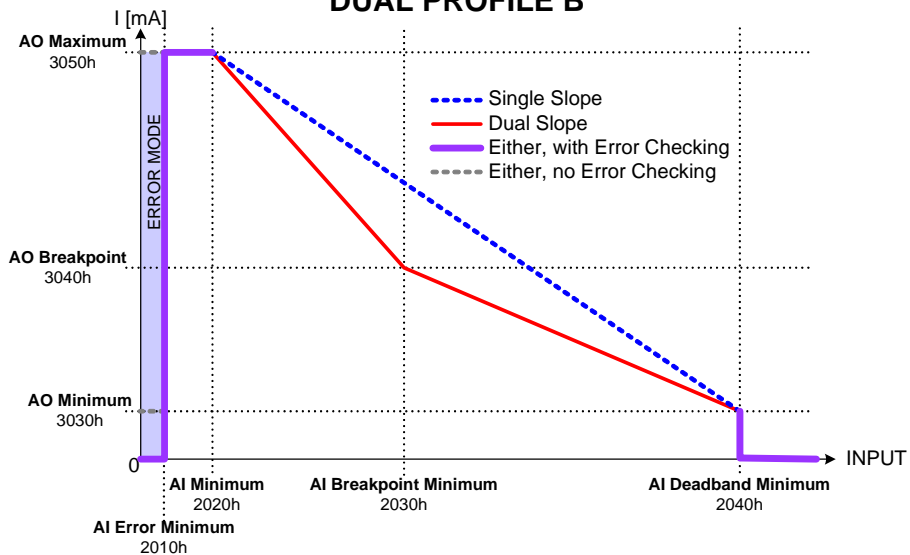

3. OBJECT DICTIONARY

The CANopen object dictionary of the Quad Controller is based on CiA device profile DS-404 V1.2. (Device profile for measurement devices and closed-loop controllers.) The object dictionary also includes some manufacturer-specific objects for extended functionality.

3.1. COMMUNICATION OBJECTS

The communication objects supported by the Quad are listed in the following table. A more detailed description of some of the objects is given in the following subchapters. Only those objects that have device-profile specific information are described. For more information on the other objects, refer to the generic CANopen protocol specification DS-301.

Index (hex)	Object	Object Type	Data Type	Access	PDO Mapping
1000	Device Type	VAR	UNSIGNED32	RO	No
1001	Error Register	VAR	UNSIGNED8	RO	No
1002	Manufacturer Status Register	VAR	UNSIGNED32	RO	No
1003	Pre-Defined Error Field	ARRAY	UNSIGNED32	RO	No
100C	Guard Time	VAR	UNSIGNED16	RW	No
100D	Life Time Factor	VAR	UNSIGNED8	RW	No
1010	Store Parameters	ARRAY	UNSIGNED32	RW	No
1011	Restore Default Parameters	ARRAY	UNSIGNED32	RW	No
1016	Consumer Heartbeat Time	ARRAY	UNSIGNED32	RW	No
1017	Producer Heartbeat Time	VAR	UNSIGNED16	RW	No
1018	Identity Object	RECORD		RO	No
1020	Verify Configuration	ARRAY	UNSIGNED32	RW	No
1029	Error Behaviour	ARRAY	UNSIGNED8	RW	No
1400	RPDO1 Communication Parameter	RECORD		RW	No
1401	RPDO2 Communication Parameter	RECORD		RW	No
1402	RPDO3 Communication Parameter	RECORD		RW	No
1403	RPDO4 Communication Parameter	RECORD		RW	No
1600	RPDO1 Mapping Parameter	RECORD		RW	No
1601	RPDO2 Mapping Parameter	RECORD		RW	No
1602	RPDO3 Mapping Parameter	RECORD		RW	No
1603	RPDO4 Mapping Parameter	RECORD		RW	No
1800	TPDO1 Communication Parameter	RECORD		RW	No
1801	TPDO2 Communication Parameter	RECORD		RW	No
1802	TPDO3 Communication Parameter	RECORD		RW	No
1803	TPDO4 Communication Parameter	RECORD		RW	No
1A00	TPDO1 Mapping Parameter	RECORD		RW	No
1A01	TPDO2 Mapping Parameter	RECORD		RW	No
1A02	TPDO3 Mapping Parameter	RECORD		RW	No
1A03	TPDO4 Mapping Parameter	RECORD		RW	No

3.1.1. PDO Parameters

All RPDOs and TPDOs in the Quad use the same default communication parameters, respectively. The PDO IDs are set according to the pre-defined connection set described in [DS-301]. All receive PDOs are set to transmission type 255, and all transmit PDOs to transmission type 254, with the event timer (subindex 5) set to 100 (100ms).

All PDOs are dynamically mappable, and the user can therefore change the mapping of the PDOs. The granularity is 8-bits, so the objects can be mapped with byte offsets. The mapping parameter records include 4 subindexes for the PDO mapping. The default PDO mappings are listed in the following tables.

RPDO1: default ID 0x200 + node ID

<i>Subindex</i>	<i>Value</i>	<i>Object</i>
0	4	Number of mapped application objects in PDO
1	0x73300110	AO Output Field Value for POUT1
2	0x73300210	AO Output Field Value for POUT2
3	0x73300310	AO Output Field Value for POUT3
4	0x73300410	AO Output Field Value for POUT4

RPDO2: default ID 0x300 + node ID

<i>Subindex</i>	<i>Value</i>	<i>Object</i>
0	1	Number of mapped application objects in PDO
1	0x62000108	DO Write State 8 Output Lines
2	0	
3	0	
4	0	

RPDO3: default ID 0x400 + node ID

<i>Subindex</i>	<i>Value</i>	<i>Object</i>
0	0	Number of mapped application objects in PDO
1	0	
2	0	
3	0	
4	0	

RPDO4: default ID 0x500 + node ID

<i>Subindex</i>	<i>Value</i>	<i>Object</i>
0	0	Number of mapped application objects in PDO
1	0	
2	0	
3	0	
4	0	

TPDO1: default ID 0x180 + node ID

Subindex	Value	Object
0	4	Number of mapped application objects in PDO
1	0x71000110	AI Input Field Value for AIN1
2	0x71000210	AI Input Field Value for AIN2
3	0x71000310	AI Input Field Value for AIN3
4	0x71000410	AI Input Field Value for AIN4

TPDO2: default ID 0x280 + node ID

Subindex	Value	Object
0	2	Number of mapped application objects in PDO
1	0x71000510	AI Input Field Value for FIN1
2	0x71000610	AI Input Field Value for FIN2
3	0	
4	0	

TPDO3: default ID 0x380 + node ID

Subindex	Value	Object
0	2	Number of mapped application objects in PDO
1	0x60000108	DI Read State 8 Input Lines
2	0x300C0108	DO Read State 8 Output Lines
3	0	
4	0	

TPDO4: default ID 0x480 + node ID

Subindex	Value	Object
0	4	Number of mapped application objects in PDO
1	0x30C00110	AO Measured Current for POUT1
2	0x30C00210	AO Measured Current for POUT2
3	0x30C00310	AO Measured Current for POUT3
4	0x30C00410	AO Measured Current for POUT4

3.1.2. Object 1000h: Device Type

This object contains information about the device type as per device profile DS-404. The value stored in this object is 0x000F0194, indicating that the Quad includes the following function blocks defined in the device profile.

- Digital Input (DI)
- Analog Input (AI)
- Digital Output (DO)
- Analog Output (AO)

Object Description

Index	1000h
Name	Device Type
Object Type	VAR
Data Type	UNSIGNED32

Entry Description

Access	RO
PDO Mapping	No
Value Range	0x000F0194
Default Value	0x000F0194

3.1.3. Object 1001h: Error Register

This object is an error register for the device. Any time there is an error detected by the Quad, the Generic Error Bit (bit 0) is set. Only if there are no errors in the module will this bit be cleared. No other bits in this register are used by the Quad.

Object Description

Index	1001h
Name	Error Register
Object Type	VAR
Data Type	UNSIGNED8

Entry Description

Access	RO
PDO Mapping	No
Value Range	00h or 01h
Default Value	0

3.1.4. Object 1003h: Pre-Defined Error Field

The object 1003h provides an error history by listing the errors in the order that they have occurred. An error is added to the top of the list when it occurs, and is immediately removed when the error condition has been cleared. The latest error is always at subindex 1, with subindex 0 containing the number of errors currently in the list. When the device is in an error-free state, the value of subindex 0 is zero.

The error list may be cleared by writing a zero to subindex 0, which will clear all errors from the list, regardless of whether or not they are still present. Clearing the list does NOT mean that the module will return to the error-free behaviour state if at least one error is still active. The Quad has a limitation of a maximum of 16 errors in the list. If the device registers more errors, the list will be truncated, and the oldest entries will be lost.

The error codes stored in the list are 32-bit unsigned numbers, consisting of two 16-bit fields. The lower 16-bit field is the EMCY error code, and the higher 16-bit field is a manufacturer-specific code. The manufacturer-specific code is divided into two 8-bit fields, with the higher byte indicating the error description, and the lower byte indicating the channel number where the error occurred.

MSB		LSB
Error Description	Channel	EMCY Error Code

See Section 4 for a complete list of the error code fields.

Object Description

Index	1003h
Name	Pre-Defined Error Field
Object Type	VAR
Data Type	UNSIGNED32

Entry Description

Subindex	0h
Description	Number of entries
Access	RO
PDO Mapping	No
Value Range	0 to 16
Default Value	0

Subindex	1h to 10h
Description	Standard error field
Access	RO
PDO Mapping	No
Value Range	UNSIGNED32
Default Value	0

3.1.5. Object 1010h: Store Parameters

This object supports the saving of parameters in non-volatile memory. In order to avoid storage of parameters by mistake, storage is only executed when a specific signature is written to the appropriate subindex. The signature is “save”.

The signature is a 32-bit unsigned number, composed of the ASCII codes of the signature characters, according to the following table:

MSB		LSB	
e	v	a	s
65h	76h	61h	73h

On reception of the correct signature to an appropriate subindex, the Quad will store the parameters in non-volatile memory, and then confirm the SDO transmission.

By read access, the object provides information about the Quad’s saving capabilities.

Object Description

Index	1010h
Name	Store Parameters
Object Type	ARRAY
Data Type	UNSIGNED32

Entry Description

Subindex	0h
Description	Largest subindex supported
Access	RO
PDO Mapping	No
Value Range	4
Default Value	4

Subindex	1h
Description	Save all parameters
Access	RW
PDO Mapping	No
Value Range	0x65766173 (write access) 1h (read access)
Default Value	1h (saves parameters on command)

Subindex	2h
Description	Save communication parameters
Access	RW
PDO Mapping	No
Value Range	0x65766173 (write access) 1h (read access)
Default Value	1h (saves parameters on command)

Subindex	3h
Description	Save application parameters
Access	RW
PDO Mapping	No
Value Range	0x65766173 (write access) 1h (read access)
Default Value	1h (saves parameters on command)

Subindex	4h
Description	Save manufacturer parameters
Access	RW
PDO Mapping	No
Value Range	0x65766173 (write access) 1h (read access)
Default Value	1h (saves parameters on command)

3.1.6. Object 1011h: Restore Default Parameters

This object supports the restoring of the default values for the object dictionary in non-volatile memory. In order to avoid restoring of parameters by mistake, the device restores the defaults only when a specific signature is written to the appropriate subindex. The signature is “load”.

The signature is a 32-bit unsigned number, composed of the ASCII codes of the signature characters, according to the following table:

MSB		LSB	
d	a	o	l
64h	61h	6Fh	6Ch

On reception of the correct signature to an appropriate subindex, the Quad will restore the defaults in non-volatile memory, and then confirm the SDO transmission. The default values are set valid after the device is reset or power-cycled.

By read access, the object provides information about the Quad’s default parameter restoring capabilities.

Object Description

Index	1011h
Name	Restore Default Parameters
Object Type	ARRAY
Data Type	UNSIGNED32

Entry Description

Subindex	0h
Description	Largest subindex supported
Access	RO
PDO Mapping	No
Value Range	4
Default Value	4

Subindex	1h
Description	Restore all default parameters
Access	RW
PDO Mapping	No
Value Range	0x64616F6C (write access) 1h (read access)
Default Value	1h (restores defaults on command)

Subindex	2h
Description	Restore default communication parameters
Access	RW
PDO Mapping	No

Value Range	0x64616F6C (write access) 1h (read access)
Default Value	1h (restores defaults on command)

Subindex	3h
Description	Restore default application parameters
Access	RW
PDO Mapping	No
Value Range	0x64616F6C (write access) 1h (read access)
Default Value	1h (restores defaults on command)

Subindex	4h
Description	Restore default manufacturer parameters
Access	RW
PDO Mapping	No
Value Range	0x64616F6C (write access) 1h (read access)
Default Value	1h (restores defaults on command)

3.1.7. Object 1016h: Consumer Heartbeat Time

The Quad can be a consumer of heartbeat objects for up to four modules. This object defines the expected heartbeat cycle time for those modules, and if set to zero, it is not used. When non-zero, the time is a multiple of 1ms, and monitoring will start after the reception of the first heartbeat from the module. If the Quad fails to receive a heartbeat from a node in the expected timeframe, it will indicate a communication error, and respond as per object 1029h.

Bits	31-24	23-16	15-0
Value	Reserved 00h	Node-ID	Heartbeat time
Encoded as		UNSIGNED8	UNSIGNED16

Object Description

Index	1016h
Name	Consumer heartbeat time
Object Type	ARRAY
Data Type	UNSIGNED32

Entry Description

Subindex	0h
Description	Number of entries
Access	RO
PDO Mapping	No
Value Range	4
Default Value	4

Subindex	1h to 4h
Description	Consumer heartbeat time
Access	RW
PDO Mapping	No
Value Range	UNSIGNED32
Default Value	0

3.1.8. Object 1018h: Identity Object

The identity object indicates the data of the Quad, including vendor id, device id, software and hardware version numbers, and the serial number.

In the Revision Number entry at subindex 3, the format of the data is as shown below

MSB			LSB
Major revision number (object dictionary)		Hardware Revision	Software Version

Object Description

Index	1018h
Name	Identity
Object Type	RECORD
Data Type	Identity Record

Entry Description

Subindex	0h
Description	Number of entries
Access	RO
PDO Mapping	No
Value Range	4
Default Value	4

Subindex	1h
Description	Vendor ID
Access	RO
PDO Mapping	No
Value Range	0x00000055
Default Value	0x00000055 (Axiomatic)

Subindex	2h
Description	Product Code
Access	RO
PDO Mapping	No
Value Range	0xAA020502
Default Value	0xAA020502

Subindex	3h
Description	Revision Number
Access	RO
PDO Mapping	No
Value Range	UNSIGNED32
Default Value	No

Subindex	4h
Description	Serial Number
Access	RO
PDO Mapping	No
Value Range	UNSIGNED32
Default Value	No

3.1.9. Object 1029h: Error Behaviour

This object controls the state that the Quad will be set into in case of an error of the type associated with the subindex. The behaviour of the Quad in each state is described in detail in section 4.

Object Description

Index	1029h
Name	Error Behaviour
Object Type	ARRAY
Data Type	UNSIGNED8

Entry Description

Subindex	0h
Description	Number of entries
Access	RO
PDO Mapping	No
Value Range	5
Default Value	5

Subindex	1h
Description	Communication Error
Access	RW
PDO Mapping	No
Value Range	0 = Pre-Operational 1 = No State Change 2 = Stopped
Default Value	0 (Pre-Operational)

Subindex	2h
Description	Digital Input Error
Access	RW
PDO Mapping	No
Value Range	0 = Pre-Operational 1 = No State Change 2 = Stopped
Default Value	1 (no state change)

Subindex	3h
Description	Analog Input Error
Access	RW
PDO Mapping	No
Value Range	0 = Pre-Operational 1 = No State Change 2 = Stopped
Default Value	1 (no state change)

Subindex	4h
Description	Digital Output Error
Access	RW
PDO Mapping	No
Value Range	0 = Pre-Operational 1 = No State Change 2 = Stopped
Default Value	1 (no state change)

Subindex	5h
Description	Analog Output Error
Access	RW
PDO Mapping	No
Value Range	0 = Pre-Operational 1 = No State Change 2 = Stopped
Default Value	1 (no state change)

3.1.10. Object 5555h: Start in Operational

This manufacturer specific object allows the unit to start in Operational mode without requiring the presence of a CANopen ® Master on the network. It is intended to be used only when running the controller as a stand-alone module. This should always be set FALSE whenever it is connected to a standard master/slave network.

Object Description

Index	5555h
Name	Start in Operational Mode
Object Type	VARIABLE
Data Type	BOOLEAN

Entry Description

Sub-Index	0h
Access	RW
PDO Mapping	No
Value Range	0 (FALSE) or 1 (TRUE)
Default Value	0 [FALSE]

3.2. DIGITAL INPUT FUNCTION BLOCK (DS-404)

The application and manufacturer objects supported by the Quad for the digital input block are listed in the following table.

Index (hex)	Object	Object Type	Data Type	Access	PDO Mapping
2000	DI Level 8 Input Lines	ARRAY	UNSIGNED8	RW	No
2001	DI Low Threshold	ARRAY	UNSIGNED16	RW	No
2002	DI High Threshold	ARRAY	UNSIGNED16	RW	No
6000	DI Read State 8 Input Lines	ARRAY	UNSIGNED8	RO	Yes
6002	DI Polarity 8 Input Lines	ARRAY	UNSIGNED8	RW	No

3.2.1. Object 2000h: DI Level 8 Input Lines

This object sets the digital input active level for input pins configured as digital inputs. The digital inputs have a software selectable pull-up/pull-down resistor, which is switched according to the state of the bit in this object. In active high mode, the pull-down resistor is enabled, so the input must be switched to a +V signal to turn on. In active low mode, the pull-up resistor is enabled, so the input must be switched to a GND signal to turn on. In either mode, the inputs do not require any external components to function properly.

Object Description

Index	2000h
Name	DI Level 8 Input Lines
Object Type	ARRAY
Data Type	UNSIGNED8

Entry Description

Subindex	0h
Description	Number of entries
Access	RO
PDO Mapping	No
Value Range	1
Default Value	1

Subindex	1h
Description	Active Level of DIN1 to DIN6
Access	RW
PDO Mapping	No
Value Range	Bit Value 0 = Active Low Input Bit Value 1 = Active High Input
Default Value	3Fh (all active high)

3.2.2. Object 2001h: DI Low Threshold

This object sets the off threshold for analog inputs configured as ON/OFF inputs. If the input is less than or equal to this value, then the input state in object 6000h is set to OFF. This input must be in the same units as object 7100h, the field value for that analog input.

Object Description

Index	2001h
Name	DI Low Threshold
Object Type	ARRAY
Data Type	UNSIGNED16

Entry Description

Subindex	0h
Description	Number of entries
Access	RO
PDO Mapping	No
Value Range	6
Default Value	6

Subindex	1h to 4h
Description	Low Threshold, AIN1 to AIN4
Access	RW
PDO Mapping	No
Value Range	0 to 2002h at subindex
Default Value	1500 [mV]

Subindex	5h to 6h
Description	Low Threshold, FIN1 to FIN2
Access	RW
PDO Mapping	No
Value Range	0 to 2002h at subindex
Default Value	2500 [25.00%]

3.2.3. Object 2002h: DI High Threshold

This object sets the on threshold for analog inputs configured as ON/OFF inputs. If the input is greater than or equal to this value, then the input state in object 6000h is set to ON. This input must be in the same units as object 7100h, the field value for that analog input.

Object Description

Index	2002h
Name	DI High Threshold
Object Type	ARRAY
Data Type	UNSIGNED16

Entry Description

Subindex	0h
Description	Number of entries
Access	RO
PDO Mapping	No
Value Range	6
Default Value	6

Subindex	1h to 4h
Description	High Threshold, AIN1 to AIN4
Access	RW
PDO Mapping	No
Value Range	2001h at subindex to 5000, for 0-5V 2001h at subindex to 10000, for 0-10V 2001h at subindex to 20000, for 0-20mA
Default Value	3500 [mV]

Subindex	5h to 6h
Description	High Threshold, FIN1 to FIN2
Access	RW
PDO Mapping	No
Value Range	2001h at subindex to 10000, for both 0-100.00% and 0-10000Hz
Default Value	7500 [75.00%]

3.2.4. Object 6000h: DI Read State 8 Input Lines

This object is used for reading data from digital input lines in 8-bit blocks. For inputs that are not configured as either digital or ON/OFF with programmable threshold by object 6112h, the corresponding bit in the read byte is always set to 0.

Object Description

Index	6000h
Name	DI Read State 8 Input Lines
Object Type	ARRAY
Data Type	UNSIGNED8

Entry Description

Subindex	0h
Description	Number of entries
Access	RO
PDO Mapping	No
Value Range	1
Default Value	1

Subindex	1h
Description	Read State of DIN1 to DIN6
Access	RO
PDO Mapping	Yes (default TPDO3, subindex 1)
Value Range	Bit Value 0 = Input Off Bit Value 1 = Input On
Default Value	0

3.2.5. Object 6002h: DI Polarity 8 Input Lines

This object is used for setting the polarity of digital input lines in 8-bit blocks. For inputs that are not configured as digital inputs by object 6112h, the corresponding bit is ignored.

Object Description

Index	6000h
Name	DI Polarity 8 Input Lines
Object Type	ARRAY
Data Type	UNSIGNED8

Entry Description

Subindex	0h
Description	Number of entries
Access	RO
PDO Mapping	No
Value Range	1
Default Value	1

Subindex	1h
Description	Polarity of DIN1 to DIN6
Access	RW
PDO Mapping	No
Value Range	Bit Value 0 = normal polarity Bit Value 1 = inverted polarity
Default Value	00h (all normal polarity)

3.3. ANALOG INPUT FUNCTION BLOCK (DS-404)

The application and manufacturer objects supported by the Quad for the analog input block are listed in the following table.

Index (hex)	Object	Object Type	Data Type	Access	PDO Mapping
2010	AI Error Minimum	ARRAY	UNSIGNED16	RW	No
2020	AI Minimum	ARRAY	UNSIGNED16	RW	No
2030	AI Breakpoint Minimum	ARRAY	UNSIGNED16	RW	No
2040	AI Deadband Minimum	ARRAY	UNSIGNED16	RW	No
2050	AI Deadband Maximum	ARRAY	UNSIGNED16	RW	No
2060	AI Breakpoint Maximum	ARRAY	UNSIGNED16	RW	No
2070	AI Maximum	ARRAY	UNSIGNED16	RW	No
2080	AI Error Maximum	ARRAY	UNSIGNED16	RW	No
2090	AI Frequency Measuring Window	ARRAY	UNSIGNED16	RW	Yes
20A0	AI Enable Error Checking 8 Lines	ARRAY	UNSIGNED8	RW	No
20B0	AI Error Response Delay	ARRAY	UNSIGNED16	RW	No
7100	AI Input Field Value	ARRAY	INTEGER16	RO	Yes
6110	AI Sensor Type	ARRAY	UNSIGNED16	RW	No
6112	AI Operating Mode	ARRAY	UNSIGNED8	RW	No
7120	AI Input Scaling 1 FV	ARRAY	INTEGER16	RW	No
7121	AI Input Scaling 1 PV	ARRAY	INTEGER16	RW	No
7122	AI Input Scaling 2 FV	ARRAY	INTEGER16	RW	No
7123	AI Input Scaling 2 PV	ARRAY	INTEGER16	RW	No
7124	AI Input Offset	ARRAY	INTEGER16	RW	No
6125	AI Autozero	ARRAY	UNSIGNED32	WO	No
7130	AI Input Process Value	ARRAY	INTEGER16	RO	Yes
6132	AI Decimal Digits PV	ARRAY	UNSIGNED8	RW	No
61A0	AI Filter Type	ARRAY	UNSIGNED8	RW	No
61A1	AI Filter Constant	ARRAY	UNSIGNED8	RW	No

3.3.1. Object 2010h: AI Error Minimum

This object sets the value that will flag an input error in the Quad if the measured field value goes below this limit. If error checking on the input is enabled by object 20A0h, then the module will flag an “out of range low” error on that channel. See section 4 for more details about error handling in the Quad. This value must be in the same units as the field value for the input as determined by the object 6110h [sensor type].

Object Description

Index	2010h
Name	AI Error Minimum
Object Type	ARRAY
Data Type	UNSIGNED16

Entry Description

Subindex	0h
Description	Number of entries
Access	RO
PDO Mapping	No
Value Range	6
Default Value	6

Subindex	1h to 4h
Description	Error Minimum, AIN1 to AIN4
Access	RW
PDO Mapping	No
Value Range	0 to 2020h at subindex
Default Value	200 [mV]

Subindex	5h to 6h
Description	Error Minimum, FIN1 to FIN2
Access	RW
PDO Mapping	No
Value Range	0 to 2020h at subindex
Default Value	100 [1.00%]

For objects 2020h to 2070h, the values must be in the same units as the field value for the input as determined by the object 6110h [sensor type]. The descriptions are valid only if the input is being used as a control single on a proportional output channel. SP = Single Profile, DP-A = Dual Profile A, DP-B = Dual Profile B, see section 2.5 ss = Single Slope, ds = Dual Slope, see section 2.5

3.3.2. Object 2020h: AI Minimum

This object is only used for SP or DP-B responses. For all other responses, this object is ignored. See the graphs in section 2.5 for more details on the output profiles.

Object Description

Index	2020h
Name	AI Minimum
Object Type	ARRAY
Data Type	UNSIGNED16

Entry Description

Subindex	0h
Description	Number of entries
Access	RO
PDO Mapping	No
Value Range	6
Default Value	6

Subindex	1h to 4h
Description	Minimum, AIN1 to AIN4
Access	RW
PDO Mapping	No
Value Range	2010h to 2030, at subindex
Default Value	500 [mV]

Subindex	5h to 6h
Description	Minimum, FIN1 to FIN2
Access	RW
PDO Mapping	No
Value Range	2010h to 2030, at subindex
Default Value	500 [5.00%]

3.3.3. Object 2030h: AI Breakpoint Minimum

This object is only used for SP:ds or DP-B:ds responses. For all other responses, this object is ignored. See the graphs in section 2.5 for more details on the output profiles.

Object Description

Index	2030h
Name	AI Breakpoint Minimum
Object Type	ARRAY
Data Type	UNSIGNED16

Entry Description

Subindex	0h
Description	Number of entries
Access	RO
PDO Mapping	No
Value Range	6
Default Value	6

Subindex	1h to 4h
Description	Breakpoint Minimum, AIN1 to AIN4
Access	RW
PDO Mapping	No
Value Range	2020h to 2040, at subindex
Default Value	1400 [mV]

Subindex	5h to 6h
Description	Breakpoint Minimum, FIN1 to FIN2
Access	RW
PDO Mapping	No
Value Range	2020h to 2040, at subindex
Default Value	2500 [25.00%]

3.3.4. Object 2040h: AI Deadband Minimum

This object is only used for DP-B responses. For all other responses, this object is ignored. See the graph in section 2.5 for more details on the output profiles.

Object Description

Index	2040h
Name	AI Deadband Minimum
Object Type	ARRAY
Data Type	UNSIGNED16

Entry Description

Subindex	0h
Description	Number of entries
Access	RO
PDO Mapping	No
Value Range	6
Default Value	6

Subindex	1h to 4h
Description	Deadband Minimum, AIN1 to AIN4
Access	RW
PDO Mapping	No
Value Range	2030h to 2050, at subindex
Default Value	2300 [mV]

Subindex	5h to 6h
Description	Deadband Minimum, FIN1 to FIN2
Access	RW
PDO Mapping	No
Value Range	2030h to 2050, at subindex
Default Value	4500 [45.00%]

3.3.5. Object 2050h: AI Deadband Maximum

This object is only used for DP-A responses. For all other responses, this object is ignored. See the graph in section 2.5 for more details on the output profiles.

Object Description

Index	2050h
Name	AI Deadband Maximum
Object Type	ARRAY
Data Type	UNSIGNED16

Entry Description

Subindex	0h
Description	Number of entries
Access	RO
PDO Mapping	No
Value Range	6
Default Value	6

Subindex	1h to 4h
Description	Deadband Maximum, AIN1 to AIN4
Access	RW
PDO Mapping	No
Value Range	2040h to 2060, at subindex
Default Value	2700 [mV]

Subindex	5h to 6h
Description	Deadband Maximum, FIN1 to FIN2
Access	RW
PDO Mapping	No
Value Range	2040h to 2060, at subindex
Default Value	5500 [55.00%]

3.3.6. Object 2060h: AI Breakpoint Maximum

This object is only used for the DP-A:ds response. For all other responses, this object is ignored. See the graph in section 2.5 for more details on the output profile.

Object Description

Index	2060h
Name	AI Breakpoint Maximum
Object Type	ARRAY
Data Type	UNSIGNED16

Entry Description

Subindex	0h
Description	Number of entries
Access	RO
PDO Mapping	No
Value Range	6
Default Value	6

Subindex	1h to 4h
Description	Breakpoint Maximum, AIN1 to AIN4
Access	RW
PDO Mapping	No
Value Range	2050h to 2070, at subindex
Default Value	3600 [mV]

Subindex	5h to 6h
Description	Breakpoint Maximum, FIN1 to FIN2
Access	RW
PDO Mapping	No
Value Range	2050h to 2070, at subindex
Default Value	7500 [75.00%]

3.3.7. Object 2070h: AI Maximum

This object is only used for SP or DP-A responses. For all other responses, this object is ignored. See the graphs in section 2.5 for more details on the output profiles.

Object Description

Index	2070h
Name	AI Maximum
Object Type	ARRAY
Data Type	UNSIGNED16

Entry Description

Subindex	0h
Description	Number of entries
Access	RO
PDO Mapping	No
Value Range	6
Default Value	6

Subindex	1h to 4h
Description	Maximum, AIN1 to AIN4
Access	RW
PDO Mapping	No
Value Range	2060h to 2080, at subindex
Default Value	4500 [mV]

Subindex	5h to 6h
Description	Maximum, FIN1 to FIN2
Access	RW
PDO Mapping	No
Value Range	2060h to 2080, at subindex
Default Value	9500 [95.00%]

3.3.8. Object 2080h: AI Error Maximum

This object sets the value that will flag an input error in the Quad if the measured field value goes above this limit. If error checking on the input is enabled by object 20A0h, then the module will flag an “out of range high” error on that channel. See section 4 for more details about error handling in the Quad. This value must be in the same units as the field value for the input as determined by the object 6110h [sensor type].

Object Description

Index	2080h
Name	AI Error Maximum
Object Type	ARRAY
Data Type	UNSIGNED16

Entry Description

Subindex	0h
Description	Number of entries
Access	RO
PDO Mapping	No
Value Range	6
Default Value	6

Subindex	1h to 4h
Description	Error Maximum, AIN1 to AIN4
Access	RW
PDO Mapping	No
Value Range	2070h at subindex to 5000, for 0-5V 2070h at subindex to 10000, for 0-10V 2070h at subindex to 20000, for 0-20mA
Default Value	4800 [mV]

Subindex	5h to 6h
Description	Error Maximum, FIN1 to FIN2
Access	RW
PDO Mapping	No
Value Range	2070h at subindex to 10000, for both 0-100.00% and 0-10000Hz
Default Value	9900 [99.00%]

3.3.9. Object 2090h: AI Frequency Measuring Window

This object is only used with the pulse inputs that are configured for frequency measurements by object 6110h [sensor type]. The value is defined as a multiple of 1ms. The number of pulses will be sample at the end of the measuring window, and the controller will then calculate the frequency of the signal. This value can be mapped to a PDO to allow the CANopen master to dynamically change the measuring window for input signals that have a wide frequency range.

Object Description

Index	2090h
Name	AI Freq Measuring Window
Object Type	ARRAY
Data Type	UNSIGNED16

Entry Description

Subindex	0h
Description	Number of entries
Access	RO
PDO Mapping	No
Value Range	2
Default Value	2

Subindex	1h
Description	FIN1 Measuring Window
Access	RW
PDO Mapping	Yes
Value Range	10 to 10000 [ms]
Default Value	1000 [ms]

Subindex	2h
Description	FIN2 Measuring Window
Access	RW
PDO Mapping	Yes
Value Range	10 to 10000 [ms]
Default Value	1000 [ms]

3.3.10. Object 20A0h: AI Enable Error Checking 8 Input Lines

This object enables or disables the input error-checking feature for each input configured for “Normal” or “ON/OFF with programmable thresholds” operation by object 6112h. If the input is configured as a digital input, error checking is automatically disabled.

Object Description

Index	20A0h
Name	AI Enable Error Checking 8 Input Lines
Object Type	ARRAY
Data Type	UNSIGNED8

Entry Description

Subindex	0h
Description	Number of entries
Access	RO
PDO Mapping	No
Value Range	1
Default Value	1

Subindex	1h
Description	Error Check for AIN1 to FIN2
Access	RW
PDO Mapping	No
Value Range	Bit Value 0 = Error Check Disabled Bit Value 1 = Error Check Enabled
Default Value	00h (all error check disabled)

3.3.11. Object 20B0h: AI Error Response Delay

This object is used to prevent intermittent input faults from overloading the bus with error messages. The value is defined as a multiple of 1ms. If a fault has been present during the entirety of the delay time, the Quad will flag an error at the input once the timer has expired. The object can be set to zero, in which case a fault will immediately trigger an error response.

Object Description

Index	20B0h
Name	AI Error Response Delay
Object Type	ARRAY
Data Type	UNSIGNED16

Entry Description

Subindex	0h
Description	Number of entries
Access	RO
PDO Mapping	No
Value Range	6
Default Value	6

Subindex	1h to 6h
Description	Error Delay, AIN1 to FIN2
Access	RW
PDO Mapping	No
Value Range	0 to 10000 [ms]
Default Value	1000 [ms]

3.3.12. Object 7100h: AI Input Field Value

This object reflects the measured value for the inputs AIN1 to AIN4 and FIN1 to FIN2. For analog inputs, the values are converted to either millivolts or microamps, depending on the object 6110h [sensor type]. For pulse inputs, the values are converted to either (duty cycle x 100) or hertz.

Object Description

Index	7100h
Name	AI Input Field Value
Object Type	ARRAY
Data Type	INTEGER16

Entry Description

Subindex	0h
Description	Number of entries
Access	RO
PDO Mapping	No
Value Range	6
Default Value	6

Subindex	1h to 4h
Description	Field Value, AIN1 to AIN4
Access	RO
PDO Mapping	Yes AIN1 default TPDO1, subindex 1 AIN2 default TPDO1, subindex 2 AIN3 default TPDO1, subindex 3 AIN4 default TPDO1, subindex 4
Value Range	0 to 5000 [mV] or 0 to 10000 [mV] or 0 to 20000 [uA]
Default Value	No

Subindex	5h to 6h
Description	Field Value, FIN1 to FIN2
Access	RO
PDO Mapping	Yes FIN1 default TPDO2, subindex 1 FIN2 default TPDO2, subindex 2
Value Range	0 to 10000 [%dc x 100] or 0 to 10000 [Hz]
Default Value	No

3.3.13. Object 6110h: AI Sensor Type

This object reflects the type of signal that is being applied to the input.

For inputs AIN1 to AIN4, the following values are allowed for this object

- Sensor Type 40 = voltage input, value range 0 to 5000 mV
- Sensor Type 42 = voltage input, value range 0 to 10000 mV
- Sensor Type 51 = current input, value range 4000 to 20000 uA
- Sensor Type 52 = current input, value range 0 to 20000 uA

Only the mentioned sensor types are supported. Writing a value other than those listed above will result in SDO abort download error, and the previous value will remain unchanged. The default value is 40, voltage input, 0 to 5000mV.

For inputs FIN1 to FIN2, the following values are allowed for this object

- Sensor Type 60 = frequency input, value range 0 to 10000 Hz
- Sensor Type 10000 = PWM duty cycle input, value range 0 to 10000 (0 to 100.00%)

Only the mentioned sensor types are supported. Writing a value other than those listed above will result in SDO abort download error, and the previous value will remain unchanged. The default value is 10000, PWM duty cycle input.

Object Description

Index	6110h
Name	AI Sensor Type
Object Type	ARRAY
Data Type	UNSIGNED16

Entry Description

Subindex	0h
Description	Number of entries
Access	RO
PDO Mapping	No
Value Range	6
Default Value	6

Subindex	1h to 4h
Description	Sensor Type, AIN1 to AIN4
Access	RW
PDO Mapping	No
Value Range	40, 42, 51, 52
Default Value	40 (voltage, 0 to 5000mV)

Subindex	5h to 6h
Description	Sensor Type, FIN1 to FIN2
Access	RW
PDO Mapping	No
Value Range	60, 10000
Default Value	10000 (PWM duty cycle)

3.3.14. Object 6112h: AI Operating Mode

This object determines how the input will operate. The following values are allowed for this object.

- Operating Mode 0 = Channel not used, input disabled
- Operating Mode 1 = Normal operation (sensor type selectable using object 6110h)
- Operating Mode 10 = Digital (controlled by Digital Input Block)
- Operating Mode 20 = ON/OFF with programmable threshold (controlled by DI Block)

Only the mentioned operating modes are supported. Writing a value other than those listed above will result in SDO abort download error, and the previous value will remain unchanged. The default value is 1, normal operation.

Object Description

Index	6112h
Name	AI Operating Mode
Object Type	ARRAY
Data Type	UNSIGNED8

Entry Description

Subindex	0h
Description	Number of entries
Access	RO
PDO Mapping	No
Value Range	6
Default Value	6

Subindex	1h to 6h
Description	Operating Mode, AIN1 to FIN2
Access	RW
PDO Mapping	No
Value Range	0, 1, 10, 20
Default Value	1 (normal operation)

3.3.15. Object 7120h: AI Input Scaling 1 FV

This object defines the field value for the first calibration point for the input channel. The value is scaled in the physical unit of the input field value, object 7100h.

Object Description

Index	7120h
Name	AI Input Scaling 1 FV
Object Type	ARRAY
Data Type	INTEGER16

Entry Description

Subindex	0h
Description	Number of entries
Access	RO
PDO Mapping	No
Value Range	6
Default Value	6

Subindex	1h to 6h
Description	Scaling 1 FV, AIN1 to FIN2
Access	RW
PDO Mapping	No
Value Range	INTEGER16
Default Value	0

3.3.16. Object 7121h: AI Input Scaling 1 PV

This object defines the process value for the first calibration point for the input channel. The value is scaled in the physical unit of the input process value, object 7130h.

Object Description

Index	7121h
Name	AI Input Scaling 1 PV
Object Type	ARRAY
Data Type	INTEGER16

Entry Description

Subindex	0h
Description	Number of entries
Access	RO
PDO Mapping	No
Value Range	6
Default Value	6

Subindex	1h to 6h
Description	Scaling 1 PV, AIN1 to FIN2
Access	RW
PDO Mapping	No
Value Range	INTEGER16
Default Value	0

3.3.17. Object 7122h: AI Input Scaling 2 FV

This object defines the field value for the second calibration point for the input channel. The value is scaled in the physical unit of the input field value, object 7100h.

Object Description

Index	7122h
Name	AI Input Scaling 2 FV
Object Type	ARRAY
Data Type	INTEGER16

Entry Description

Subindex	0h
Description	Number of entries
Access	RO
PDO Mapping	No
Value Range	6
Default Value	6

Subindex	1h to 6h
Description	Scaling 2 FV, AIN1 to FIN2
Access	RW
PDO Mapping	No
Value Range	INTEGER16
Default Value	0

3.3.18. Object 7123h: AI Input Scaling 2 PV

This object defines the process value for the second calibration point for the input channel. The value is scaled in the physical unit of the input process value, object 7130h.

Object Description

Index	7123h
Name	AI Input Scaling 2 PV
Object Type	ARRAY
Data Type	INTEGER16

Entry Description

Subindex	0h
Description	Number of entries
Access	RO
PDO Mapping	No
Value Range	6
Default Value	6

Subindex	1h to 6h
Description	Scaling 2 PV, AIN1 to FIN2
Access	RW
PDO Mapping	No
Value Range	INTEGER16
Default Value	0

3.3.19. Object 7124h: AI Input Offset

This object defines an offset for the input channel, which added to the input value after scaling the input field value to process value. The value is scaled in the physical unit of the input process value, object 7130h.

Object Description

Index	7124h
Name	AI Input Offset
Object Type	ARRAY
Data Type	INTEGER16

Entry Description

Subindex	0h
Description	Number of entries
Access	RO
PDO Mapping	No
Value Range	6
Default Value	6

Subindex	1h to 6h
Description	Input Offset, AIN1 to FIN2
Access	RW
PDO Mapping	No
Value Range	INTEGER16
Default Value	0

3.3.20. Object 6125h: AI Autozero

Writing a signature “zero” to this object causes a modification of object 7124h value, AI Input Offset, such that object 7130h [AI Input PV] becomes zero. This zeroing cycling is performed once, upon reception of the signature to the appropriate subindex, but the zeroing procedure can be performed any time, as many times as required.

The signature is a 32-bit unsigned number, composed of the ASCII codes of the signature characters, according to the following table:

MSB		LSB	
o	r	e	z
6Fh	72h	65h	7Ah

On reception of the correct signature to an appropriate subindex, the Quad will perform the zeroing operation for that input, and then confirm the SDO transmission.

Object Description

Index	6125h
Name	AI Autozero
Object Type	ARRAY
Data Type	UNSIGNED32

Entry Description

Subindex	0h
Description	Number of entries
Access	RO
PDO Mapping	No
Value Range	6
Default Value	6

Subindex	1h to 6h
Description	Autozero, AIN1 to FIN2
Access	WO
PDO Mapping	No
Value Range	0x6F72657A
Default Value	No

3.3.21. Object 7130h: AI Input Process Value

This object reflects the input process value after having been scaled from the measured field value.

Object Description

Index	7130h
Name	AI Input Process Value
Object Type	ARRAY
Data Type	INTEGER16

Entry Description

Subindex	0h
Description	Number of entries
Access	RO
PDO Mapping	No
Value Range	6
Default Value	6

Subindex	1h to 6h
Description	Process Value, AIN1 to FIN2
Access	RO
PDO Mapping	Yes
Value Range	INTEGER16
Default Value	0

3.3.22. Object 6132h: AI Decimal Digits PV

This object sets the number of decimal digits included in the process value. For example, if the number of decimal digits is set to 2, the process value 1.234 would be represented by a value of 123 as the process value.

Object Description

Index	6132h
Name	AI Decimal Digits PV
Object Type	ARRAY
Data Type	UNSIGNED8

Entry Description

Subindex	0h
Description	Number of entries
Access	RO
PDO Mapping	No
Value Range	6
Default Value	6

Subindex	1h to 6h
Description	Decimal Digits, AIN1 to FIN2
Access	RW
PDO Mapping	No
Value Range	0 to 9
Default Value	0

3.3.23. Object 61A0h: AI Filter Type

All inputs, except for frequency inputs, are sampled every 10ms. This object defines the filter type that is applied to the input field value. The available filters are

- Filter Type 0 = No Filter
- Filter Type 1 = Moving Average
- Filter Type 2 = Repeating Average

Frequency inputs are measured based on the value in object 2090h [Frequency Measuring Window]. Filters are not available for frequency inputs (object 6110h = 60 at subindex 5 or 6), and object 61A0h is ignored.

Calculation of the moving average:

$$\text{Value}_N = \text{Value}_{N-1} + \frac{(\text{Input} - \text{Value}_{N-1})}{\text{FilterConstant}}$$

The filter constant is defined in object 61A1h

Calculation of the repeating average:

$$\text{Value} = \frac{\sum \text{Input}_N}{N}$$

At every reading of the input value, it is added to the sum. At every Nth read, the sum is divided by N, and the result is written to object 7130h [input process value]. The value and counter will be set to zero for the next read.

Object Description

Index	61A0h
Name	AI Filter Type
Object Type	ARRAY
Data Type	UNSIGNED8

Entry Description

Subindex	0h
Description	Number of entries
Access	RO
PDO Mapping	No
Value Range	6
Default Value	6

Subindex	1h to 6h
Description	PV Filter Type, AIN1 to FIN2
Access	RW
PDO Mapping	No
Value Range	UNSIGNED8
Default Value	0 (no filter)

3.3.24. Object 61A1h: AI Filter Constant

This object defines a constant used in filtering the AI Input PV. For different filter types, object 61A0h, this object has slightly different meanings:

- With the moving average filter, this constant is used as the divisor for the sum term.
- With the repeating average filter, this constant sets the number of samples taken into the filter before calculating the average.

Object Description

Index	61A1h
Name	AI Filter Constant
Object Type	ARRAY
Data Type	UNSIGNED8

Entry Description

Subindex	0h
Description	Number of entries
Access	RO
PDO Mapping	No
Value Range	6
Default Value	6

Subindex	1h to 6h
Description	Filter Constant, AIN1 to FIN2
Access	RW
PDO Mapping	No
Value Range	UNSIGNED8
Default Value	1

3.4. DIGITAL OUTPUT FUNCTION BLOCK (DS-404)

The application and manufacturer objects supported by the Quad for the digital output block are listed in the following table.

Index (hex)	Object	Object Type	Data Type	Access	PDO Mapping
3001	DO Control Input	ARRAY	UNSIGNED8	RW	No
3002	DO Response 8 Output Lines	ARRAY	UNSIGNED8	RW	No
300B	DO Error Response Delay	ARRAY	UNSIGNED16	RW	No
300C	DO Read State 8 Output Lines	ARRAY	UNSIGNED8	RO	Yes
6200	DO Write State 8 Output Lines	ARRAY	UNSIGNED8	RW	Yes
6202	DO Polarity 8 Output Lines	ARRAY	UNSIGNED8	RW	No
6206	DO Fault Mode 8 Output Lines	ARRAY	UNSIGNED8	RW	No
6207	DO Fault State 8 Output Lines	ARRAY	UNSIGNED8	RW	No

3.4.1. Object 3001h: DO Control Input

This object defines the control signal for the digital output. If set to 0, CANopen Message, then the output will be controlled by writes to object 6200h. However, if set to one of the inputs on the Quad, then it will respond to changes of state at the input without the need for any messages from the CANopen bus. The following values are allowed for this object.

- Control Input 0 = CANopen Message (in this case writes to object 6200h)
- Control Input 1 = Analog Input 1
- Control Input 2 = Analog Input 2
- Control Input 3 = Analog Input 3
- Control Input 4 = Analog Input 4
- Control Input 5 = Pulse Input 1
- Control Input 6 = Pulse Input 2
- Control Input 11 = Digital Input 1
- Control Input 12 = Digital Input 2
- Control Input 13 = Digital Input 3
- Control Input 14 = Digital Input 4
- Control Input 15 = Digital Input 5
- Control Input 16 = Digital Input 6

Only the mentioned control inputs are supported. Writing a value other than those listed above will result in SDO abort download error, and the previous value will remain unchanged. The default value is 0, CANopen Message.

Note 1: If the control input is set from 1 to 6, the input will be interpreted as an ON/OFF input with programmable thresholds, even if it isn't configured this way by object 6112h [AI operating mode]. This means that the same input could be used as both a normal input signal for another output AND as an ON/OFF input for a digital output, so long as the low and high threshold values, objects 2001h and 2002h, are set to appropriate values.

Note 2: If the control input is set from 11 to 16, then the corresponding input MUST be configured as a digital input by object 6112h [AI operating mode]. If the input is not configured as a digital input, then the control input for the digital output will always read off.

Note 3: If outputs POUT1 to POUT4 are NOT configured as a digital output by object 6310h, then the controller ignores then the values in subindexes 1 to 4, and the control inputs for those channels are actually determined by object 3010h [AO Control Input].

Object Description

Index	3001h
Name	DO Control Input
Object Type	ARRAY
Data Type	UNSIGNED8

Entry Description

Subindex	0h
Description	Number of entries
Access	RO
PDO Mapping	No
Value Range	5
Default Value	5

Subindex	1h to 4h
Description	DO Control Input, POUT1 to POUT4 set as DO
Access	RW
PDO Mapping	No
Value Range	0,1,2,3,4,5,6,11,12,13,14,15,16
Default Value	0 (CANopen Message)

Subindex	5h
Description	DO Control Input, DOUT
Access	RW
PDO Mapping	No
Value Range	0,1,2,3,4,5,6,11,12,13,14,15,16
Default Value	0 (CANopen Message)

3.4.2. Object 3002h: DO Response 8 Output Lines

This object is used for setting the response for digital output lines in 8-bit blocks. For proportional outputs that are not configured as digital, the corresponding bit is ignored. In normal ON/OFF mode, the output responds to changes of state at the input signal as per object 6202h [DO polarity]. In latched mode, object 6202h is ignored, and when the input comes on, the output will come on, and stay on. When the input comes on again (after having been off), the output will turn off, and stay off until the output comes on again, repeating the cycle.

Object Description

Index	3002h
Name	DO Response 8 Output Lines
Object Type	ARRAY
Data Type	UNSIGNED8

Entry Description

Subindex	0h
Description	Number of entries
Access	RO
PDO Mapping	No
Value Range	1
Default Value	1

Subindex	1h
Description	Response, all Digital Outputs
Access	RW
PDO Mapping	No
Value Range	Bit Value 0 = Normal ON/OFF Bit Value 1 = Latched
Default Value	00h (all normal ON/OFF)

3.4.3. Object 300Bh: DO Error Response Delay

This object is used to prevent intermittent digital output faults from overloading the bus with error messages. The value is defined as a multiple of 1ms. If a fault has been present during the entirety of the delay time, the Quad will flag an error at the output once the timer has expired. The object can be set to zero, in which case a fault will immediately trigger an error response. For proportional outputs that are not configured as digital, the corresponding value in the subindex is ignored, and instead the delay is determined by object 30B0h [AO Error Response Delay].

Object Description

Index	300Bh
Name	DO Error Response Delay
Object Type	ARRAY
Data Type	UNSIGNED16

Entry Description

Subindex	0h
Description	Number of entries
Access	RO
PDO Mapping	No
Value Range	5
Default Value	5

Subindex	1h to 4h
Description	Error Delay, POUT1 to POUT4 set as DO
Access	RW
PDO Mapping	No
Value Range	0 to 10000 [ms]
Default Value	1000 [ms]

Subindex	5h
Description	Error Delay, DOUT
Access	RW
PDO Mapping	No
Value Range	0 to 10000 [ms]
Default Value	1000 [ms]

3.4.4. Object 300Ch: DO Read State 8 Output Lines

This object is used for reading the actual state of digital output lines in 8-bit blocks. For proportional outputs that are not configured as digital, the corresponding bit in the read byte is always set to 0.

Object Description

Index	300Ch
Name	DO Read State 8 Output Lines
Object Type	ARRAY
Data Type	UNSIGNED8

Entry Description

Subindex	0h
Description	Number of entries
Access	RO
PDO Mapping	No
Value Range	1
Default Value	1

Subindex	1h
Description	Read State, all Digital Outputs
Access	RO
PDO Mapping	Yes (default TPDO3, subindex 2)
Value Range	Bit Value 0 = OFF Bit Value 1 = ON
Default Value	0

3.4.5. Object 6200h: DO Write State 8 Output Lines

This object is used for writing the state of digital output lines in 8-bit blocks. For proportional outputs that are not configured as digital, the corresponding bit in the byte is ignored. For digital outputs with an on-board control input (non-zero value in object 3001h), writes to this object will have no effect on the state of the output.

Object Description

Index	6200h
Name	DO Write State 8 Output Lines
Object Type	ARRAY
Data Type	UNSIGNED8

Entry Description

Subindex	0h
Description	Number of entries
Access	RO
PDO Mapping	No
Value Range	1
Default Value	1

Subindex	1h
Description	Write State, all Digital Outputs
Access	RW
PDO Mapping	Yes (default RPDO2, subindex 1)
Value Range	Bit Value 0 = Set DO off Bit Value 1 = Set DO on
Default Value	0

3.4.6. Object 6202h: DO Polarity 8 Output Lines

This object is used for setting the polarity of digital output lines in 8-bit blocks. For proportional outputs that are not configured as digital, the corresponding bit is ignored. When the bit is set, inverse polarity is active, such that the control input being ON will set the output OFF, and vice versa.

Object Description

Index	6202h
Name	DO Polarity 8 Output Lines
Object Type	ARRAY
Data Type	UNSIGNED8

Entry Description

Subindex	0h
Description	Number of entries
Access	RO
PDO Mapping	No
Value Range	1
Default Value	1

Subindex	1h
Description	Polarity, all Digital Outputs
Access	RW
PDO Mapping	No
Value Range	Bit Value 0 = Normal polarity Bit Value 1 = Inverse polarity
Default Value	00h (all normal polarity)

3.4.7. Object 6206h: DO Fault Mode 8 Output Lines

This object defines the fault mode response for digital outputs in 8-bit blocks. For proportional outputs that are not configured as digital, the corresponding bit is ignored. It determines whether the output shall continue to operate normally when the Quad detects an error, or if the output shall be driven to the state defined in object 6207h. For more details about the Quad error response, see section 4.

- Bit value 0 = output continues to operate normally in controller fault state
- Bit value 1 = take action defined in object 6207h in controller fault state

Object Description

Index	6206h
Name	DO Fault Mode 8 Output Lines
Object Type	ARRAY
Data Type	UNSIGNED8

Entry Description

Subindex	0h
Description	Number of entries
Access	RO
PDO Mapping	No
Value Range	1
Default Value	1

Subindex	1h
Description	Fault Mode, all Digital Outputs
Access	RW
PDO Mapping	No
Value Range	UNSIGNED8
Default Value	1Fh (all as per object 6207h)

3.4.8. Object 6207h: DO Fault State 8 Output Lines

This object defines the state that digital outputs will be driven to in fault situations in 8-bit blocks. For proportional outputs that are not configured as digital, the corresponding bit is ignored.

- Bit value 0 = drive output off in controller fault state
- Bit value 1 = drive output on in controller fault state

Object Description

Index	6207h
Name	DO Fault State 8 Output Lines
Object Type	ARRAY
Data Type	UNSIGNED8

Entry Description

Subindex	0h
Description	Number of entries
Access	RO
PDO Mapping	No
Value Range	1
Default Value	1

Subindex	1h
Description	Fault State, all Digital Outputs
Access	RW
PDO Mapping	No
Value Range	UNSIGNED8
Default Value	00h (all off in fault mode)

3.5. ANALOG OUTPUT FUNCTION BLOCK (DS-404)

The application and manufacturer objects supported by the Quad for the analog output block are listed in the following table.

Index (hex)	Object	Object Type	Data Type	Access	PDO Mapping
3010	AO Control Input	ARRAY	UNSIGNED8	RW	No
3020	AO Response	ARRAY	UNSIGNED8	RW	No
3030	AO Minimum Current	ARRAY	INTEGER16	RW	No
3040	AO Breakpoint Current	ARRAY	INTEGER16	RW	No
3050	AO Maximum Current	ARRAY	INTEGER16	RW	No
3060	AO Dither Frequency	ARRAY	UNSIGNED16	RW	No
3070	AO Dither Amplitude	ARRAY	UNSIGNED16	RW	No
3080	AO Ramp Up	ARRAY	UNSIGNED16	RW	No
3090	AO Ramp Down	ARRAY	UNSIGNED16	RW	No
30A0	AO Ramp Control	ARRAY	UNSIGNED8	RW	No
30B0	AO Error Response Delay	ARRAY	UNSIGNED16	RW	No
30C0	AO Measured Current	ARRAY	UNSIGNED16	RO	Yes
7300	AO Output Process Value	ARRAY	INTEGER16	RO	No
6302	AO Decimal Digits PV	ARRAY	UNSIGNED8	RW	No
6310	AO Output Type	ARRAY	UNSIGNED16	RW	No
7320	AO Output Scaling 1 PV	ARRAY	INTEGER16	RW	No
7321	AO Output Scaling 1 FV	ARRAY	INTEGER16	RW	No
7322	AO Output Scaling 2 PV	ARRAY	INTEGER16	RW	No
7323	AO Output Scaling 2 FV	ARRAY	INTEGER16	RW	No
7330	AO Output Field Value	ARRAY	INTEGER16	RW	Yes
6340	AO Fault Mode	ARRAY	UNSIGNED8	RW	No
7341	AO Fault FV	ARRAY	INTEGER16	RW	No
7F50	Received PV 16	ARRAY	INTEGER16	RW	Yes
6F52	Received PV Status	ARRAY	UNSIGNED8	RW	Yes

3.5.1. Object 3010h: AO Control Input

This object defines the control signal for the digital output. If set to 0, CANopen Message, then the output will be controlled by writes to object 7330h (FV) or 7F50h (PV). However, if set to one of the inputs on the Quad, then it will respond to changes of state at the input without the need for any messages from the CANopen bus. The following values are allowed for this object.

- Control Input 0 = CANopen Message (in this case writes to object 7330h or 7F50h)
- Control Input 1 = Analog Input 1
- Control Input 2 = Analog Input 2
- Control Input 3 = Analog Input 3
- Control Input 4 = Analog Input 4
- Control Input 5 = Pulse Input 1
- Control Input 6 = Pulse Input 2

Only the mentioned control inputs are supported. Writing a value other than those listed above will result in SDO abort download error, and the previous value will remain unchanged. The default value is 0, CANopen Message.

Note 1: If the control input is non-zero, then the corresponding input must be configured for normal operation using object 6112h.

Note 2: If outputs POUT1 to POUT4 are NOT configured as a current output by object 6310h, then the controller ignores then the values in subindexes 1 to 4, and the control inputs for those channels are actually determined by object 3001h [DO Control Input].

Object Description

Index	3010h
Name	AO Control Input
Object Type	ARRAY
Data Type	UNSIGNED8

Entry Description

Subindex	0h
Description	Number of entries
Access	RO
PDO Mapping	No
Value Range	4
Default Value	4

Subindex	1h to 4h
Description	AO Control Input, POUT1 to POUT4
Access	RW
PDO Mapping	No
Value Range	0,1,2,3,4,5,6
Default Value	0 (CANopen Message)

3.5.2. Object 3020h: AO Response

This object defines the output response profile for the proportional outputs. For more information on the profiles, see section 2.5. The following values are allowed for this object.

- Response 0 = Single Profile, Single Slope
- Response 1 = Single Profile, Dual Slope
- Response 2 = Dual Profile A, Single Slope
- Response 3 = Dual Profile A, Dual Slope
- Response 4 = Dual Profile B, Single Slope
- Response 5 = Dual Profile B, Dual Slope

Only the mentioned responses are supported. Writing a value other than those listed above will result in SDO abort download error, and the previous value will remain unchanged. The default value is 0, Single Profile, Single Slope.

If the control input for the output in object 3010h is set to zero (CANopen Message), then this object is ignored. Instead, the output current is determined by object 7330h [AO Output Field Value].

Object Description

Index	3020h
Name	AO Response
Object Type	ARRAY
Data Type	UNSIGNED8

Entry Description

Subindex	0h
Description	Number of entries
Access	RO
PDO Mapping	No
Value Range	4
Default Value	4

Subindex	1h to 4h
Description	AO Response, POUT1 to POUT4
Access	RW
PDO Mapping	No
Value Range	0,1,2,3,4,5
Default Value	0 (Single Profile, Single Slope)

For objects 3030h to 3050h, the values must be in the same units as the field value for the output, in this case milliamps. The descriptions are valid only if the control input in object 3010h is non-zero, otherwise these objects are ignored.

3.5.3. Object 3030h: AO Minimum Current

This object defines the current that will be applied to a load as per the minimum current part of the graphs in section 2.5.

Object Description

Index	3030h
Name	AO Minimum Current
Object Type	ARRAY
Data Type	INTEGER16

Entry Description

Subindex	0h
Description	Number of entries
Access	RO
PDO Mapping	No
Value Range	4
Default Value	4

Subindex	1h to 4h
Description	Minimum Current, POUT1 to POUT4
Access	RW
PDO Mapping	No
Value Range	0 to 2000 [mA]
Default Value	0 [mA]

3.5.4. Object 3040h: AO Breakpoint Current

This object defines the current that will be applied to a load as per the breakpoint current parts of the graphs in section 2.5.

Object Description

Index	3040h
Name	AO Breakpoint Current
Object Type	ARRAY
Data Type	INTEGER16

Entry Description

Subindex	0h
Description	Number of entries
Access	RO
PDO Mapping	No
Value Range	4
Default Value	4

Subindex	1h to 4h
Description	Breakpoint Current, POUT1 to POUT4
Access	RW
PDO Mapping	No
Value Range	0 to 2000 [mA]
Default Value	750 [mA]

3.5.5. Object 3050h: AO Maximum Current

This object defines the current that will be applied to a load as per the maximum current part of the graphs in section 2.5.

Object Description

Index	3050h
Name	AO Maximum Current
Object Type	ARRAY
Data Type	INTEGER16

Entry Description

Subindex	0h
Description	Number of entries
Access	RO
PDO Mapping	No
Value Range	4
Default Value	4

Subindex	1h to 4h
Description	Maximum Current, POUT1 to POUT4
Access	RW
PDO Mapping	No
Value Range	0 to 2000 [mA]
Default Value	1500 [mA]

3.5.6. Object 3060h: AO Dither Frequency

This object defines the frequency of the dither that will be superimposed on top of the output signal for the proportional outputs. The value is defined as a multiple of 1Hz.

Object Description

Index	3060h
Name	AO Dither Frequency
Object Type	ARRAY
Data Type	UNSIGNED16

Entry Description

Subindex	0h
Description	Number of entries
Access	RO
PDO Mapping	No
Value Range	4
Default Value	4

Subindex	1h to 4h
Description	Dither Frequency, POUT1 to POUT4
Access	RW
PDO Mapping	No
Value Range	50 to 400 [Hz]
Default Value	200 [Hz]

3.5.7. Object 3070h: AO Dither Amplitude

This object defines the amplitude of the dither that will be superimposed on top of the output signal for the proportional outputs. The value is defined as a multiple of 1mA. If set to zero, the dithering is disabled for that output.

Object Description

Index	3070h
Name	AO Dither Amplitude
Object Type	ARRAY
Data Type	UNSIGNED16

Entry Description

Subindex	0h
Description	Number of entries
Access	RO
PDO Mapping	No
Value Range	4
Default Value	4

Subindex	1h to 4h
Description	Dither Amplitude, POUT1 to POUT4
Access	RW
PDO Mapping	No
Value Range	0 to 400 [mA]
Default Value	0 [mA]

3.5.8. Object 3080h: AO Ramp Up

This object defines the length of time it would take for the output current to ramp up from zero to the highest current on its output profile. The value is defined as a multiple of 1ms.

Note1: Since objects 3030h, 3040h, 3050h [minimum, breakpoint, maximum current] can be set anywhere from 0 to 2000mA, any one of these objects could be the highest current on the profile.

Note2: If object 3010h [AO control input] for that channel is set to zero (CANopen Message), then the highest current is always defined as the maximum rated current, 2000mA.

Object Description

Index	3080h
Name	AO Ramp Up
Object Type	ARRAY
Data Type	UNSIGNED16

Entry Description

Subindex	0h
Description	Number of entries
Access	RO
PDO Mapping	No
Value Range	4
Default Value	4

Subindex	1h to 4h
Description	Ramp Up, POUT1 to POUT4
Access	RW
PDO Mapping	No
Value Range	0 to 10000 [ms]
Default Value	1500 [ms]

3.5.9. Object 3090h: AO Ramp Down

This object defines the length of time it would take for the output current to ramp down from the highest current on its output profile to zero. The value is defined as a multiple of 1ms. See Notes 1 and 2 in object 3080h.

Object Description

Index	3090h
Name	AO Ramp Down
Object Type	ARRAY
Data Type	UNSIGNED16

Entry Description

Subindex	0h
Description	Number of entries
Access	RO
PDO Mapping	No
Value Range	4
Default Value	4

Subindex	1h to 4h
Description	Ramp Down, POUT1 to POUT4
Access	RW
PDO Mapping	No
Value Range	0 to 10000 [ms]
Default Value	1500 [ms]

3.5.10. Object 30A0h: AO Ramp Control

This object defines whether or not the controller will use ramps when adjusting the output current. Ramps are a useful feature to prevent an abrupt jump in the current in the case of a large step change at the input. In the case of an emergency shutoff due to a fault condition, ramps are never used. See section 4 for more details about error responses in the Quad. The following values are allowed for this object.

- Ramp Control 0 = Ramps are disabled
- Ramp Control 1 = Always use ramps (except in emergency shutoffs)
- Ramp Control 2 = Use ramps unless control input = 0, CANopen Message

Only the mentioned ramp controls are supported. Writing a value other than those listed above will result in SDO abort download error, and the previous value will remain unchanged. The default value is 2.

Object Description

Index	30A0h
Name	AO Ramp Control
Object Type	ARRAY
Data Type	UNSIGNED16

Entry Description

Subindex	0h
Description	Number of entries
Access	RO
PDO Mapping	No
Value Range	4
Default Value	4

Subindex	1h to 4h
Description	Ramp Control, POUT1 to POUT4
Access	RW
PDO Mapping	No
Value Range	0, 1, 2
Default Value	2

3.5.11. Object 30B0h: AO Error Response Delay

This object is used to prevent intermittent proportional output faults from overloading the bus with error messages. The value is defined as a multiple of 1ms. If a fault has been present during the entirety of the delay time, the Quad will flag an error at the output once the timer has expired. The object can be set to zero, in which case a fault will immediately trigger an error response. For proportional outputs that are configured as digital, the corresponding value in the subindex is ignored, and instead the delay is determined by object 300Bh [DO Error Response Delay].

Object Description

Index	30B0h
Name	AO Error Response Delay
Object Type	ARRAY
Data Type	UNSIGNED16

Entry Description

Subindex	0h
Description	Number of entries
Access	RO
PDO Mapping	No
Value Range	4
Default Value	4

Subindex	1h to 4h
Description	Error Delay, POUT1 to POUT4
Access	RW
PDO Mapping	No
Value Range	0 to 10000 [ms]
Default Value	1000 [ms]

3.5.12. Object 30C0h: AO Measured Current

This object indicates the actual current applied to the loads as measured by the controller. The value is defined as a multiple of 1mA.

Object Description

Index	30C0h
Name	AO Measured Current
Object Type	ARRAY
Data Type	UNSIGNED16

Entry Description

Subindex	0h
Description	Number of entries
Access	RO
PDO Mapping	No
Value Range	4
Default Value	4

Subindex	1h to 4h
Description	Measured Current, POUT1 to POUT4
Access	RW
PDO Mapping	Yes POUT1 default TPDO4, subindex 1 POUT2 default TPDO4, subindex 2 POUT3 default TPDO4, subindex 3 POUT4 default TPDO4, subindex 4
Value Range	0 to 2000 [mA]
Default Value	No

3.5.13. Object 7300h: AO Output Process Value

This object is the process value that is fed into the analog output function block. (See block diagram in section 2.5) Since this is a read-only object, the only way this object is written is if the value in object 7F50h [Received PV] is validated by object 6F52h. The process value can be in any physical unit (bar, rpm, etc.) or in any custom format. The output value is scaled into the field value using the scaling coefficients defined in objects 7320h to 7323h.

Object Description

Index	7300h
Name	AO Output Process Value
Object Type	ARRAY
Data Type	INTEGER16

Entry Description

Subindex	0h
Description	Number of entries
Access	RO
PDO Mapping	No
Value Range	4
Default Value	4

Subindex	1h to 4h
Description	Process Value, POUT1 to POUT4
Access	RO
PDO Mapping	No
Value Range	INTEGER16
Default Value	0

3.5.14. Object 6302h: AO Decimal Digits PV

This object sets the number of decimal digits included in the process value.

Object Description

Index	6302h
Name	AO Decimal Digits PV
Object Type	ARRAY
Data Type	UNSIGNED8

Entry Description

Subindex	0h
Description	Number of entries
Access	RO
PDO Mapping	No
Value Range	4
Default Value	4

Subindex	1h to 4h
Description	Decimal Digits PV, POUT1 to POUT4
Access	RW
PDO Mapping	No
Value Range	0 to 9
Default Value	0

3.5.15. Object 6310h: AO Output Type

This object defines whether or not the output will act as a close-loop current or a digital output. If configured as a digital output, the analog output block will no longer apply. Instead, the digital output block will apply to the output. The following values are allowed for this object.

- Output Type 20 = current output (0 to 2000mA)
- Output Type 1000 = digital output (up to 2000mA)

Only the mentioned output types are supported. Writing a value other than those listed above will result in SDO abort download error, and the previous value will remain unchanged. The default value is 20, current output.

Object Description

Index	6310h
Name	AO Output Type
Object Type	ARRAY
Data Type	UNSIGNED16

Entry Description

Subindex	0h
Description	Number of entries
Access	RO
PDO Mapping	No
Value Range	4
Default Value	4

Subindex	1h to 4h
Description	Output Type, POUT1 to POUT4
Access	RW
PDO Mapping	No
Value Range	20, 1000
Default Value	20 (current output)

3.5.16. Object 7320h: AO Output Scaling 1 PV

This object defines the process value for the first calibration point for the output channel. The value is scaled in the physical unit of the output process value, object 7300h.

Object Description

Index	7320h
Name	AO Output Scaling 1 PV
Object Type	ARRAY
Data Type	INTEGER16

Entry Description

Subindex	0h
Description	Number of entries
Access	RO
PDO Mapping	No
Value Range	4
Default Value	4

Subindex	1h to 4h
Description	Scaling 1 PV, POUT1 to POUT4
Access	RW
PDO Mapping	No
Value Range	INTEGER16
Default Value	0

3.5.17. Object 7321h: AO Output Scaling 1 FV

This object defines the field value for the first calibration point for the output channel. The value is scaled in the physical unit of the output field value, object 7330h.

Object Description

Index	7321h
Name	AO Output Scaling 1 FV
Object Type	ARRAY
Data Type	INTEGER16

Entry Description

Subindex	0h
Description	Number of entries
Access	RO
PDO Mapping	No
Value Range	4
Default Value	4

Subindex	1h to 4h
Description	Scaling 1 FV, POUT1 to POUT4
Access	RW
PDO Mapping	No
Value Range	INTEGER16
Default Value	0

3.5.18. Object 7322h: AO Output Scaling 2 PV

This object defines the process value for the second calibration point for the output channel. The value is scaled in the physical unit of the output process value, object 7300h.

Object Description

Index	7322h
Name	AO Output Scaling 2 PV
Object Type	ARRAY
Data Type	INTEGER16

Entry Description

Subindex	0h
Description	Number of entries
Access	RO
PDO Mapping	No
Value Range	4
Default Value	4

Subindex	1h to 4h
Description	Scaling 2 PV, POUT1 to POUT4
Access	RW
PDO Mapping	No
Value Range	INTEGER16
Default Value	0

3.5.19. Object 7323h: AO Output Scaling 2 FV

This object defines the field value for the second calibration point for the output channel. The value is scaled in the physical unit of the output field value, object 7330h.

Object Description

Index	7323h
Name	AO Output Scaling 2 FV
Object Type	ARRAY
Data Type	INTEGER16

Entry Description

Subindex	0h
Description	Number of entries
Access	RO
PDO Mapping	No
Value Range	4
Default Value	4

Subindex	1h to 4h
Description	Scaling 2 FV, POUT1 to POUT4
Access	RW
PDO Mapping	No
Value Range	INTEGER16
Default Value	0

3.5.20. Object 7330h: AO Output Field Value

This object defines the field value of the proportional outputs. The FV is automatically updated if object 7300h [AO Output Process Value] is changed. Alternatively, it can be written to directly to set the output, as long as the corresponding bit in object 6F52h [Received PV status] is set to invalid. The value is defined as a multiple of 1mA.

Object Description

Index	7330h
Name	AO Output Field Value
Object Type	ARRAY
Data Type	INTEGER16

Entry Description

Subindex	0h
Description	Number of entries
Access	RO
PDO Mapping	No
Value Range	4
Default Value	4

Subindex	1h to 4h
Description	Field Value, POUT1 to POUT4
Access	RW
PDO Mapping	Yes POUT1 default RPDO1, subindex 1 POUT2 default RPDO1, subindex 2 POUT3 default RPDO1, subindex 3 POUT4 default RPDO1, subindex 4
Value Range	INTEGER16
Default Value	0

3.5.21. Object 6340h: AO Fault Mode

This object defines the fault mode response for proportional outputs. For proportional outputs that are configured as digital, the corresponding subindex is ignored. It determines whether the output shall continue to operate normally when the Quad detects an error, or if the output shall be driven to the value defined in object 7341h. For more details about the Quad error response, see section 4.

- Value 0 = output continues to operate normally in controller fault state
- Value 1 = write the value defined in object 7341h in object 7330h, in controller fault state

Object Description

Index	6340h
Name	AO Fault Mode
Object Type	ARRAY
Data Type	UNSIGNED8

Entry Description

Subindex	0h
Description	Number of entries
Access	RO
PDO Mapping	No
Value Range	4
Default Value	4

Subindex	1h to 4h
Description	Fault Mode, POUT1 to POUT4
Access	RW
PDO Mapping	No
Value Range	0, 1
Default Value	1 (output as per 7341h)

3.5.22. Object 7341h: AO Fault FV

This object defines the value that proportional outputs will be driven to in fault situations. For proportional outputs that are configured as digital, the object is ignored.

Object Description

Index	7341h
Name	AO Fault FV
Object Type	ARRAY
Data Type	INTEGER16

Entry Description

Subindex	0h
Description	Number of entries
Access	RO
PDO Mapping	No
Value Range	4
Default Value	4

Subindex	1h to 4h
Description	Fault FV, POUT1 to POUT4
Access	RW
PDO Mapping	No
Value Range	0 to 2000 [mA]
Default Value	0

3.5.23. Object 7F50h: Received PV 16

This object is a generic input process value that is used to write to the analog output function block's process value, object 7300h. If and only if the value of object 6F52h at the same subindex is set to validate the PV will the data from 7F50h be copied to object 7300h.

Object Description

Index	7F50h
Name	Received PV 16
Object Type	ARRAY
Data Type	INTEGER16

Entry Description

Subindex	0h
Description	Number of entries
Access	RO
PDO Mapping	No
Value Range	4
Default Value	4

Subindex	1h to 4h
Description	Received PV, POUT1 to POUT4
Access	RW
PDO Mapping	Yes
Value Range	INTERGER16
Default Value	0

3.5.24. Object 6F52h: Received PV Status

This object is used to validate the value in object 7F50h [Received PV] such that the value will be copied to object 7300h [AO output PV] and subsequently used as the output command. If this object is set to the non-validated value, the Received PV is not used. However, writes to object 7330h [AO Output FV] is allowed at any time, thus the field value can be used to control the outputs, even when the process values have not been validated.

The value of object 6F52h is invalidated after the value in object 7F50h is copied to 7300h. Therefore, if the object is not mapped into a PDO, the user must validate the Received PV by SDO writes before the Received PV will be used.

The following status values are allowed for object 6F52h.

- Value 0 = Received PV value not validated (writes to object 7F50h are ignored)
- Value 1 = Received PV value is validated (value in object 7F50h is copied to 7300h)

Object Description

Index	6F52h
Name	Received PV Status
Object Type	ARRAY
Data Type	UNSIGNED8

Entry Description

Subindex	0h
Description	Number of entries
Access	RO
PDO Mapping	No
Value Range	4
Default Value	4

Subindex	1h to 4h
Description	PV Status, POUT1 to POUT4
Access	RW
PDO Mapping	Yes
Value Range	0, 1
Default Value	0 (Received PV invalid)

4. ERROR HANDLING

4.1. Emergency Frame Codes (EMCY)

The EMCY messages include the error code, which is a combination of the general error codes defined in DS-301 and the additional information of the error codes, as defined by DS-404. Object 1003h [Pre-Defined Error Field] maintains a list of all active error codes in the Quad.

The error codes stored in the list are 32-bit unsigned numbers, consisting of two 16-bit fields. The lower 16-bit field is the EMCY error code, and the higher 16-bit field is a manufacturer-specific code. The manufacturer-specific code is divided into two 8-bit fields, with the higher byte indicating the error description, and the lower byte indicating the channel number where the error occurred.

MSB			LSB
Error Description	Channel	EMCY Error Code	

Supported EMCY Codes

EMCY Error Code (hex)	Meaning
0000	Error Reset or No Error
2320	Short Circuit at Output
3300	Open Circuit at Output
8130	Life Guard or Heartbeat Error
FF00	Out of Range Low at Input
FF01	Out of Range High at Input
FF02	Error at Digital Output (DOUT only)

Supported Error Descriptions

Description (hex)	Meaning
01	Fault at an analog input
02	Fault at a digital output
04	Fault at a proportional output
08	Lost Heartbeat or Life Guard from a node

Supported Channel Numbers

Description (hex)	Meaning
01	AIN1 or POUT1 (depending on description)
02	AIN2 or POUT2 (depending on description)
03	AIN3 or POUT3 (depending on description)
04	AIN4 or POUT4 (depending on description)
05	FIN1 or DOUT (depending on description)
06	FIN2

For example, the Quad detects a short circuit on proportional output channel 3.

EMCY Code = 0x2320
Additional Information = 0x0403
Resulting Code in 1003h = 0x04032320

4.2. Quad Fault Mode Behaviour

The objects associated with the error response in the Quad are listed in the following table. See section 3 for a detailed description of each object.

<i>Index (hex)</i>	<i>Object</i>
1001	Error Register
1003	Pre-Defined Error Field
1029	Error Behaviour
2010	AI Error Minimum
2080	AI Error Maximum
20B0	AI Error Response Delay
300B	DO Error Response Delay
6206	DO Fault Mode 8 Output Lines
6207	DO Fault State 8 Output Lines
30B0	AO Error Response Delay
6340	AO Fault Mode
7341	AO Fault FV

If at any time there is an active fault on the Quad, bit 1 (Generic Error) of the Error Register will be set. If and only if there are no active faults will this bit be clear.

If a heartbeat or life-guard event is detected, then the controller will add the appropriate error code (see section 4.1) to the top of the list in object 1003h. The “channel” portion of the error code will contain the node ID of the module that failed to send the heartbeat/life guard message within the expected time. The controller will check subindex 1 (communication) of object 1029h to see if it has to change state.

All other faults that the Quad can detect are related to the onboard I/O. Each type of I/O has an object call “Error Response Delay” associated with the various I/O channel. Upon reset of the controller, all possible faults that can be detected by the Quad are in the inactive state. When a fault is first detected, it enters an error pending state, and a timer is loaded with the delay time. For a fault to become active, it must remain present until the timer has decremented to zero. If at any time during the delay period the fault is cleared, the fault reverts back to the inactive state, and the delay timer stops. (It is only active while an error is pending.) If the fault is still present when the timer has elapsed, then the fault enters the active state, and the appropriate error code (see section 4.1) is add to the top of the list in object 1003h. For AI, DO and AO faults, the controller will check subindexes 3, 4 and 5 respectively of object 1029h to see if it has to change state.

Pre-Operational Behaviour

In the pre-operational state, the controller will not allow any SDO writes to control the outputs of the Quad. (PDO communication is disallowed by the standard [DS-301]) This means that if the subindex for an output in either object 3001h [DO Control Input] or 3010h [AO Control Input] (depending on the type of output) is zero (CANopen Message), then the output is always off in the pre-operational state.

However, if the control input is one of the inputs on the Quad, then the output will be controlled by the appropriate digital, analog or pulse input. PDO feedback of the I/O is obviously disabled.

When there is at least one active fault in the controller, the digital outputs will behave as per objects 6206h and 6207h, while proportional outputs will behave as per objects 6340h and 7341h.

Operational Behaviour

In the operational state, the controller behaves as per the descriptions in Section 2.

When there is at least one active fault in the controller, the digital outputs will behave as per objects 6206h and 6207h, while proportional outputs will behave as per objects 6340h and 7341h.

Stopped Behaviour

As per the standard [DS-301], the controller stops all communication except for network management functions and node guarding/heartbeat, if active. In the stopped state, all outputs are always off, so objects 6206h, 6207h, 6340h and 7341h are ignored.

APPENDIX A – TECHNICAL SPECIFICATIONS

Input Specifications

Power Supply Input - Nominal	12 or 24VDC nominal 8...36 VDC power supply range NB. The maximum total current draw on the power supply pins is 6 Amps @ 24VDC, at one time.
Surge and Reverse Polarity Protection	Provided
All Inputs	Up to 6 inputs are selectable by the user and are arranged as 4 analog (named as AIN1...AIN4) and 2 frequency (named as FIN1 and FIN2). All inputs, except for frequency and counter, are sampled every 10ms. All inputs operate over the full power supply range of 8...36VDC. Note the current input is limited to a max. of 10V for continuous operation. With the CANopen® model, AX020502, all input channels are completely independent of each other as well as can simultaneously control an on-board output and send a message to the CANopen bus. A convenient feature of the CANopen® Quad is the ability to map any input on the board as the control signal for any output.
Analog Input Configuration	Up to 4 analog inputs are available. Refer to Table 1.0. Each analog input can be configured for any one of the following options. <ul style="list-style-type: none"> • Disable input • 0...5VDC or 0...10VDC • 4...20mA or 0...20mA • Digital input (On/Off)
Frequency Input Configuration	Up to 2 frequency inputs are available. Refer to Table 1.0. Each frequency input can be configured for any one of the following options. <ul style="list-style-type: none"> • Disable input • PWM signal • Pulse (Hz or RPM) • Digital input (On/Off)
Analog Ground	One analog ground connection is provided.
Output Reference Voltages	1 +5V, 10 mA NB. Reference voltage is available if digital inputs are active high. Regulation at +/-1% accuracy is provided.
Input Impedance	10 kOhms for all inputs except 0(4)-20 mA which uses a 249 Ohm current sense resistor

Table 1.0 Inputs to AX020502

Input Type	Description
Disable Inputs	Each input can be configured as a disable input command. When disable is selected, no CAN messages associated with that channel are sent to the network.
Universal Analog Inputs	Up to 4 analog inputs are available. 0...5VDC or 0...10VDC 4...20mA or 0...20mA Accuracy of 0-5V input (inputs 1-4) is +/- 50 mV. Accuracy of 0-10V input (1-4) is +/-100 mV.
Digital Inputs	Up to 6 digital inputs are available. The input can be configured for either an active high input (switch is connected to a +V signal when ON) or an active low input (switch is connected to a GND signal when ON) and threshold levels are programmable.
PWM Signal Inputs	Up to 2 PWM inputs are available to interface to a PWM signal from an ECM, PLC or other. PWM Signal Frequency: 0 – 10,000 Hz Amplitude: 5-12V PWM Duty Cycle: 0 to 100% NB. At ≤1 kHz the input accuracy is +/- 1%. At > 1kHz, it is +/- 5%.(Inputs 5 and 6)
Pulse Inputs	Up to 2 pulse inputs are available (Hertz). Accuracy of pulse input (inputs 5,6) is +/- 1%.

Output Specifications

Proportional Outputs	<p>High side (sourcing) High frequency PWM The 4 outputs are configurable as proportional or on/off as follows and are named POUT1...POUT4. Four independent proportional outputs (0...2A) NB. The maximum total current draw on the power supply pins is 6 Amps @ 24VDC, at one time.</p> <table border="1"> <thead> <tr> <th colspan="2">Table 2.0: Proportional Output Adjustments</th> </tr> <tr> <th>Adjustable Parameter</th> <th>Description</th> </tr> </thead> <tbody> <tr> <td>Output Current Adjustments</td> <td>0- I_{max} (2A) Both minimum and maximum current settings are user configurable.</td> </tr> <tr> <td>Superimposed Dither</td> <td>Dither adjustments are configurable for each channel. Dither Amplitude: 0 mA (factory default) Adjustable from 0-400 mA Dither Frequency: 200 Hz (factory default) Adjustable from 50-400 Hz</td> </tr> <tr> <td>Ramp Rates</td> <td>Ramp adjustments are configurable for each channel. 1,000 mSec (default) Adjustable from 0 to 10,000 mSec (10 sec.).</td> </tr> </tbody> </table>	Table 2.0: Proportional Output Adjustments		Adjustable Parameter	Description	Output Current Adjustments	0- I _{max} (2A) Both minimum and maximum current settings are user configurable.	Superimposed Dither	Dither adjustments are configurable for each channel. Dither Amplitude: 0 mA (factory default) Adjustable from 0-400 mA Dither Frequency: 200 Hz (factory default) Adjustable from 50-400 Hz	Ramp Rates	Ramp adjustments are configurable for each channel. 1,000 mSec (default) Adjustable from 0 to 10,000 mSec (10 sec.).
Table 2.0: Proportional Output Adjustments											
Adjustable Parameter	Description										
Output Current Adjustments	0- I _{max} (2A) Both minimum and maximum current settings are user configurable.										
Superimposed Dither	Dither adjustments are configurable for each channel. Dither Amplitude: 0 mA (factory default) Adjustable from 0-400 mA Dither Frequency: 200 Hz (factory default) Adjustable from 50-400 Hz										
Ramp Rates	Ramp adjustments are configurable for each channel. 1,000 mSec (default) Adjustable from 0 to 10,000 mSec (10 sec.).										
Proportional Output Logic	<p>The output current is proportional to the control input signal.</p> <p>For the proportional outputs, there are up to six output profiles that can be selected to determine how the output will react to a change at the input. Refer to the graphs below for details.</p>										
Digital Output	<p>High side (sourcing) One digital output ($\leq 5A$) which is named as DOUT.</p>										
Output Accuracy	+/-1%										
Protection	<p>Overcurrent protection is provided on both proportional and digital outputs. Short circuit protection is provided on both proportional and digital outputs.</p>										
Error Conditions	If an error on the input is detected, the output of the controller shuts off.										

General Specifications

Microprocessor	Motorola MC56F8346
Control Logic	Standard embedded software is provided.
CAN Interface	1 CAN port (CANopen®)
Network Termination	It is necessary to terminate the network with external termination resistors. The resistors are 120 Ohm, 0.25W minimum, metal film or similar type. They should be placed between CAN_H and CAN_L terminals at both ends of the network.
RS-232 Port	Available for diagnostic purposes.
User Interface	A CANopen master on the network or a PC-based CANopen configuration tool (not supplied) to access the object dictionary and an USB-CAN converter (not supplied) is used for configuration during initial set-up.
Operating Conditions	-40 to 85°C (-40 to 185°F)
Weight	0.55 lbs. (0.25 kg)
Protection	IP67; Unit is conformal coated within the housing. Plugs carry an IP69 rating.

Note: CANopen® is a registered community trade mark of CAN in Automation e.V.



OUR PRODUCTS

Battery Chargers
CAN bus Controls
Current Converters
DC/DC Power Converters
DC Voltage Signal Converters
Engine Management Controls
Fan Drive Controllers
Gateways
Hydraulic Valve Controllers
I/O Controls
LVDT Simulators
Machine Control Systems
Motor Controls
PID Controls
Position Sensors, Angle Measurement Inclinometers
Power Supplies
PWM Signal Converters
Resolver Signal Conditioners
Service Tools
Signal Conditioners
Surge Suppressors

OUR MISSION

Axiomatic provides electronic machine controls, components, and systems to the off-highway, military, power generation, material handling and industrial OEM markets.

We provide efficient, innovative solutions that focus on adding value for our customers.

We emphasize service and partnership with our customers, suppliers, and employees to build long term relationships and mutual trust.

QUALITY DESIGN AND MANUFACTURING

Axiomatic is an ISO9000:2001 registered facility.

SERVICE

All products to be returned to Axiomatic require a Return Materials Authorization Number (RMA#).

Please provide the following information when requesting an RMA number:

- Serial number, part number
- Axiomatic invoice number and date
- Hours of operation, description of problem
- Wiring set up diagram, application
- Other comments as needed

When preparing the return shipping paperwork, please note the following. The commercial invoice for customs (and packing slip) should state the harmonized international HS (tariff code), valuation and return goods terminology, as shown in italics below. The value of the units on the commercial invoice should be identical to their purchase price.

*Goods Made In Canada (or Finland)
Returned Goods for Warranty Evaluation, HS: 9813.00
Valuation Identical Goods
Axiomatic RMA#*

WARRANTY, APPLICATION APPROVALS/LIMITATIONS

Axiomatic Technologies Corporation reserves the right to make corrections, modifications, enhancements, improvements, and other changes to its products and services at any time and to discontinue any product or service without notice. Customers should obtain the latest relevant information before placing orders and should verify that such information is current and complete. Users should satisfy themselves that the product is suitable for use in the intended application. All our products carry a limited warranty against defects in material and workmanship. Please refer to our Warranty, Application Approvals/Limitations and Return Materials Process as described on www.axiomatic.com/service.html.

CONTACTS

Axiomatic Technologies Corporation
5915 Wallace Street
Mississauga, ON
CANADA L4Z 1Z8
TEL: +1 905 602 9270
FAX: +1 905 602 9279
www.axiomatic.com

Axiomatic Technologies Oy
Höytämöntie 6
33880 Lempäälä
FINLAND
TEL: +358 3 3595 600
FAX: +358 3 3595 660
www.axiomatic.fi