

- I** AUTOMAZIONI A PISTONE PER CANCELLI A BATTENTE
- GB** PISTON AUTOMATIONS FOR SWING GATES
- F** AUTOMATIONS A PISTON POUR PORTAILS BATTANTS
- D** HYDRAULISCHER DREHTORANTRIEB
- E** AUTOMATIZACIONES A PISTON PARA PORTONES CON BATTIENTE
- P** AUTOMATIZAÇÕES A PISTÃO PARA PORTÕES COM BATENTE

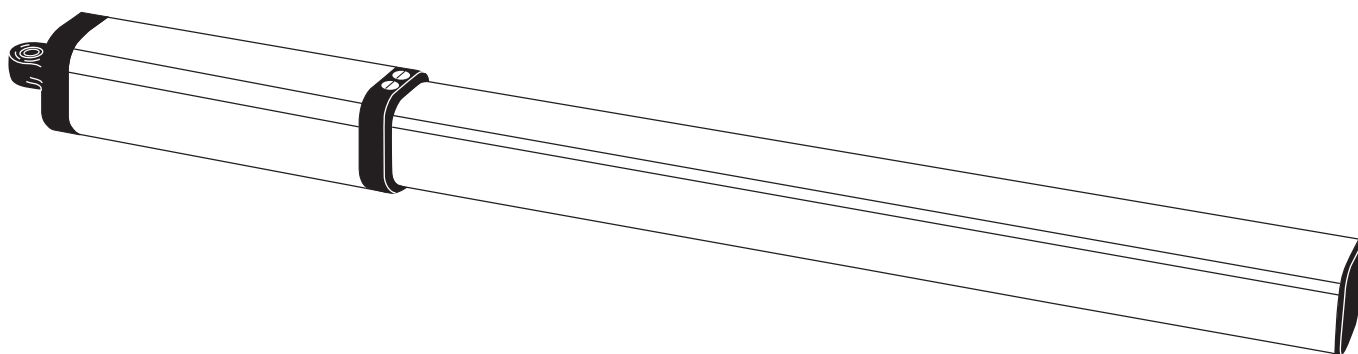

# LUX



**ISTRUZIONI D'USO E DI INSTALLAZIONE**  
**INSTALLATION AND USER'S MANUAL**  
**INSTRUCTIONS D'UTILISATION ET D'INSTALLATION**  
**GEBRAUCHS-UND MONTAGEANLEITUNG**  
**INSTRUCCIONES DE USO Y DE INSTALACION**  
**INSTRUÇÕES DE USO E DE INSTALAÇÃO**



**AZIENDA CON SISTEMA DI GESTIONE**  
**INTEGRATO CERTIFICATO DA DNV**  
**= UNI EN ISO 9001:2000 =**  
**UNI EN ISO 14001:2004**

Via Lago di Vico, 44  
 36015 Schio (VI)  
 Tel.naz. 0445 696511  
 Tel.int. +39 0445 696533  
 Fax 0445 696522  
 Internet: [www.bft.it](http://www.bft.it)  
 E-mail: [sales@bft.it](mailto:sales@bft.it)

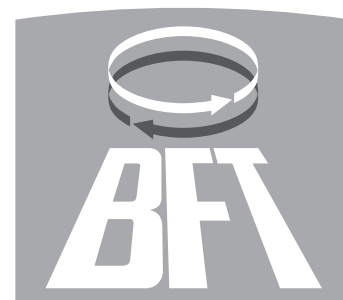

Thank you for buying this product, our company is sure that you will be more than satisfied with the product's performance. The product is supplied with a "Warnings" leaflet and an "Instruction booklet". These should both be read carefully as they provide important information about safety, installation, operation and maintenance. This product complies with the recognised technical standards and safety regulations. We declare that this product is in conformity with the following European Directives: 89/336 EEC and 73/23/EEC (and subsequent amendments).

### 1) GENERAL SAFETY

**WARNING! An incorrect installation or improper use of the product can cause damage to persons, animals or things.**

- The "Warnings" leaflet and "Instruction booklet" supplied with this product should be read carefully as they provide important information about safety, installation, use and maintenance.
- Scrap packing materials (plastic, cardboard, polystyrene etc) according to the provisions set out by current standards. Keep nylon or polystyrene bags out of children's reach.
- Keep the instructions together with the technical brochure for future reference.
- This product was exclusively designed and manufactured for the use specified in the present documentation. Any other use not specified in this documentation could damage the product and be dangerous.
- The Company declines all responsibility for any consequences resulting from improper use of the product, or use which is different from that expected and specified in the present documentation.
- Do not install the product in explosive atmosphere.
- The construction components of this product must comply with the following European Directives: 89/336/EEC, 73/23/EEC and subsequent amendments. As for all non-EEC countries, the above-mentioned standards as well as the current national standards should be respected in order to achieve a good safety level.
- The Company declines all responsibility for any consequences resulting from failure to observe Good Technical Practice when constructing closing structures (door, gates etc.), as well as from any deformation which might occur during use.
- The installation must comply with the provisions set out by the following European Directives: 89/336/EEC, 73/23/EEC and subsequent amendments.
- Disconnect the electrical power supply before carrying out any work on the installation. Also disconnect any buffer batteries, if fitted.
- Fit an omnipolar or magnetothermal switch on the mains power supply, having a contact opening distance equal to or greater than 3,5 mm.
- Check that a differential switch with a 0.03A threshold is fitted just before the power supply mains.
- Check that earthing is carried out correctly: connect all metal parts for closure (doors, gates etc.) and all system components provided with an earth terminal.
- Fit all the safety devices (photocells, electric edges etc.) which are needed to protect the area from any danger caused by squashing, conveying and shearing.
- Position at least one luminous signal indication device (blinker) where it can be easily seen, and fix a Warning sign to the structure.
- The Company declines all responsibility with respect to the automation safety and correct operation when other manufacturers' components are used.
- Only use original parts for any maintenance or repair operation.

- Do not modify the automation components, unless explicitly authorised by the company.
- Instruct the product user about the control systems provided and the manual opening operation in case of emergency.
- Do not allow persons or children to remain in the automation operation area.
- Keep radio control or other control devices out of children's reach, in order to avoid unintentional automation activation.
- The user must avoid any attempt to carry out work or repair on the automation system, and always request the assistance of qualified personnel.
- Anything which is not expressly provided for in the present instructions, is not allowed.
- Installation must be carried out using the safety devices and controls prescribed by the EN 12978 Standard.
- **Warning:** during the first manoeuvring cycles, some oil may leak out after being deposited in the breather channel during transport.
- **Warning:** an excessively fast manual manoeuvre can cause oil to leak out.

### 2) GENERAL OUTLINE

A compact, sturdy oleodynamic piston, available in a wide range of models to fit any need and field of operation. It is available in versions both with or without (reversible) hydraulic lock, that need to be equipped with an electric lock to hold the gate both closed and open.

The emergency release is obtained with the special key provided.

The adjustment of the pushing force is extremely precise and is performed by means of two by-pass valves that act as an antisquash safety. The operation at the end of the stroke is controlled electronically by a timer in the control panel. The LUX series includes special versions with slowdown in the closing phase (Mod. "R") while the LUX FC series is especially suited to areas prone to heavy snowfalls or where the central gate stop cannot be provided (see specific instruction manual).

### 3) THE MAIN PARTS IN THE AUTOMATION (fig. 1)

- M) Single phase 2 pole motor protected by thermal circuit breaker
- P) Hydraulic lobe pump
- D) Fluid distributor with adjustment valves
- C) Cylinder with piston

Standard components:

- gate post and gate brackets - release key and bypass adjustment
- drive capacitor - instruction booklet.

### 4) TECHNICAL SPECIFICATIONS

Power supply:	230V~±10% - 50 Hz (*)
Motor:	2800 min <sup>-1</sup>
Power absorption:	250W
Capacitor:	6.3 µF
Current absorption:	1.4A
Max. pressure:	30 bar
Pump delivery:	See Table 1
Pushing force:	3000N
Pulling force:	2600 N
Working stroke:	See Table 1
Impact reaction:	hydraulic clutch
Manual manoeuvres:	by release key
Max. no. manoeuvres in 24:	See table 1
Thermal protection:	160° C
Ambient temperature:	-10° C ÷ 60° C
Protection:	IP 57

TABLE 1

MOD	TYPE OF LOCK	PUMP l/min	WORKING TIME (s)	MAX.WING LENGHT/WEIGHT		STROKE WORKING/TOT		MANOEUVRES
				(m)	(Kg)	(mm)	(mm)	24h
LUX	electric lock	1.2	17	2	300	270	290	500
LUX B	hydraulic closing	1.2	17	2	300	270	290	500
LUX 2B	hydraulic clos./open	1.2	17	2	300	270	290	500
LUX L	electric lock	0.6	33	2-4	300/500	270	290	350
LUX G	electric lock	0.6	48	5-2	300/800	390	410	250
LUX GV	electric lock	1.2	28	3,5	300	390	410	500
LUX MB	hydraulic closing	0.9	23	2	300	270	290	500

Controller weight:	8.7 kg
Dimensions:	:see fig. 2
Circuit oil:	idrolux
(*) Special voltages on request	

## 5) INSTALLATION OF THE ACTUATOR

### 5.1) Preliminary checks

Check:

- that the structure of the gate is rigid and strong enough. In any case, the actuator must push against a reinforced point in the leaf
- that the leaves move manually without excessive effort for the whole of their stroke
- that the door stops are mounted on the leaves
- If the gate being installed is not new, check whether its components are worn.

Repair or replace any worn or damaged parts.

Automation reliability and safety are directly influenced by the condition of the gate's structure.

### 5.2) Installation values

The values to be known for installation can be found in the table related to the model being installed (fig. 3-4), with reference also to the diagram in fig. 5. The diagram in fig. 5 uses the following legend:

<b>P</b>	Gate-post fastening rear bracket
<b>F</b>	Leaf fastening front fork
<b>a-b</b>	"P" bracket installation values
<b>C</b>	Distance between fixing points (see fig. 2)
<b>D</b>	Gate length
<b>X</b>	Distance from gate axis to the edge of the post
<b>Z</b>	always over 45 mm (b - X)
<b>kg</b>	max. weight of leaf (Table 1)
$\alpha^\circ$	leaf opening in degrees

### 5.3) How to read the installation dimensions (fig- 3-4)

From the tables (fig. 3-4), select "a" and "b" according to the angle in degrees  $\alpha^\circ$  that the gate has to open. Each table shows the ideal value for "a" and "b" for an opening of  $\alpha^\circ = 90^\circ$  at constant speed.

In this condition, the sum of "a" plus "b" gives the value of the working stroke "Cu" (fig. 2).

If there is too large a difference between "a" and "b", the leaf will not travel smoothly and the pushing or pulling force will fluctuate during its stroke.

When "a" and "b" are at their maximum, the piston develops the maximum force. This condition is particularly useful for heavy gates or gates with very long leaves.

**WARNING!** The LUX models having a rod with adjustment ball joint enable the rod to be lengthened or shortened by about 6 mm., but only if it is set in the position shown in fig. 9 before being installed. When installed, this adjustment will allow for correcting the stroke of the rod. Fig. 10 shows the oscillation to which the LUX models with front and rear joint are subject with respect to the horizontal axis.

### 5.4) Off-standard installations

Fig. 6 - need for a recess to house the controller when the leaf is completely opened; Fig. 6 gives the size of the recess for the different LUX models.

Fig. 7 - if the "b" value is higher than the values listed in the installation tables, the leaf's hinge pivot should be shifted, or a recess be made in the gate-post (fig. 8).

### 5.5) Mounting the brackets to the gate-post and to the gate-leaf.

Fix the bracket "P" (fig. 11) to the gate-post with a good welding.

The fork "F" should be welded in the same way to the gate leaf along the distance "C" as shown in fig. 5, **taking care that the operator is installed within the limits shown in Fig. 10.**

### 5.5) Mounting the brackets to the gate-post and to the gate-leaf.

- If the gate-post is in brick, the plate "PF" must be welded to a metal base (mod. PLE) and set soundly into the post using adequately sized cramps "Z" welded to the back of the plate (fig. 12).
- If the gate-post is in stone, the plate "PF" welded to a metal base (mod. PLE) can be fixed with four metal expansion plugs "T" (fig. 13). If a larger gate is being installed it would be better to weld the plate "PF" to an angular base (fig. 14).

 **WARNING: Avoid installing the operator too close to the ground, so as to prevent rain or snow from being sucked in by the operator breather.**

## 6) GROUND GATE STOPS

For the controller to operate correctly the gate stops "F" must be used both in opening and closing, as shown in fig. 15.

The gate stops should prevent the rod of the actuator from reaching its end of stroke. Fig. 16 gives the values which ensure a perfect installation when the actuator is performing the pushing or pulling function. They must be placed so that about a 5-10 mm margin of travel is maintained in the rod. This margin prevents any malfunctions.

### 7) FITTING THE ELECTRIC LOCK

This is only necessary on models without a hydraulic lock at closing end of stroke.

The electric lock **mod. EBP** (fig. 17) consists of a continuous electromagnet with ground catch. As long as the gearmotor is operating, this device features a non-stop excitation and maintains the bolt "D" lifted until it reaches the closing end of stroke without creating any friction. This characteristic enables the pushing force to be reduced in closing which will improve the antisquash safety level.

### 8) MOUNTING THE CABLE-CLAMP (fig. 18)

**WARNING!** Fix the board "B" to the base "F" with the screws "V" provided. Place the rubber "G" in its seat in the board "B". Slide the nut "D" onto the power cable and pass the cable over board "B" as shown in the picture. Tighten nut "D" until the power cable is clamped.

N.B. The board "B" can be fitted onto both the right and left of the base "F", as required (see picture).

The bottom of board "B" has a spiralled recess to eventually receive a spiralled sheath "GS" in PVC ( $\varnothing=12$  - PG9).

### 9) THE ELECTRICAL PLANT SET-UP

Set the electrical plant (fig. 19) according to the current standards for electrical plants. Keep the power supply connections definitely separated from the auxiliary connections (photocells, rubber skirts, control devices, etc.).

**WARNING! For connection to the mains, use a multipolar cable with a minimum of 3x1.5mm<sup>2</sup> cross section and complying with the previously mentioned regulations. For example, if the cable is out side (in the open), it has to be at least equal to H07RN-F, but if it is on the inside (or outside but placed in a plastic cable channel) it has to be or at least equal to H05VV-F with section 3x1.5mm<sup>2</sup>.**

Perform the connections of the control and safety devices in compliance with the above mentioned standards.

Fig. 19 indicates the number of connections and the sections for 100 m. long power supply cables. For distances of over 100 m., calculate the cable section depending on the automation actual load. If the length of the auxiliary connections exceeds 50 metres or if they pass through critical areas subject to disturbances, we advise to disconnect the control and safety devices with suitable relays.

**The connector blocks for the power supply must be placed at a height greater than that of the actuators so as to avoid oil leakages (Fig. 19).**

### 9.1) Automation main components (fig. 19)

**I)** Type approved omnipolar switch with 3,5 mm min. contact opening, provided with overload and short-circuit protection, used to break the automation connection from the mains. If not present, provide the automation with a type approved differential switch with adequate capacity and a 0.03 A threshold.

**Qr)** Control unit with built-in receiver

**SPL)** Pre-heating board for operation at temperatures below 5° C (optional)

**S)** Key selector

**AL)** Blinker tuned in with antenna and RG58 cable

**M)** Actuator

**Fte)** Pair of outside photocells (transmitters)

**Fre)** Pair of outside photocells (receivers)

**Fti)** Pair of inside photocells with CF column (transmitters)

**Fri)** Pair of inside photocells with CF column (receivers)

**T)** 1-2-4 channel transmitter

**IMPORTANT:** Before operating the actuator electrically, unscrew the bleeder screw "S" (fig. 20) found under the joint block and keep it for future uses. Remove the bleeder screw "S" only after having installed the actuator.

### 10) ADJUSTING THE PUSHING FORCE

 **WARNING: Check that the impact force value measured at the points established by the EN 12445 standard is lower than that specified in the EN 12453 standard.**

The adjustment is made by two valves marked "close" and "open" which control the pushing force during closing and opening respectively. By turning the valves towards "+", the force is increased, while by turning them towards "-" it is reduced.

To ensure an adequate antisquash safety, the pushing force must be adjusted to just over the push needed to move the leaf, both in closing and opening. In any event, the pushing force at the end of the leaf, must not exceed the limits prescribed by the regulations indicated above. For no reason should the adjustment valves (bypass) be fully closed.

The actuator does not have electric limit switches. Therefore the motors stop when the working time set in the control unit has expired. The time set must be increased by 2-5 sec.'s with respect to the time in which the leaves reach the ground gate stops.

## 11) MANUAL OPENING

### 11.1) Versions with hydraulic lock

In case of emergency, for example during a power cut, the gate can be released by inserting the same key "C" used to adjust the bypass valve into the triangular pivot "P" found under the actuator (fig. 21) and turning it anti-clockwise. The gate can then be opened manually following the same speed as an automatic opening.

To restore the actuator to electrical operation, turn the key clockwise until pivot "P" is locked.

### 11.2) Versions without hydraulic lock

It is sufficient to open the electric lock with its key and move the leaf manually.

## 12) COVER POSITIONS

The "C" cover of all LUX models can be changed from right to left by inverting the position of the cap "T" (fig. 23).

To fit the bypass guard (fig. 24), place it in position and insert it under the rod cover "C".

## 13) CHECKING THE AUTOMATION

Before considering the automation completely operational, the following checks must be made with great care:

- Check that all the components are firmly anchored.
- Control that all the safety means work properly (i.e. photocells, pneumatic skirt, etc.).
- Check the emergency manoeuvre control.
- Check the opening and closing manoeuvres using the controls.
- Check the control unit's electronic logic in normal (or customised) operation.
- Remove the bleeder screw.

## 14) USE OF THE AUTOMATION

Since the automation may be remote controlled either by radio or a Start button, it is essential that all safeties are checked frequently.

Any malfunction should be corrected immediately by a qualified specialist. Keep children at a safe distance from the field of action of the automation.

## 15) THE CONTROLS

The controls can come in various forms (i.e. manual, remote controlled, limited access by magnetic badge, etc.) depending on needs and installation characteristics. For details on the various command systems, consult the specific instruction booklets.

Anyone using the automation must be instructed in its operation and controls.

## 16) MAINTENANCE

All maintenance on the controller must be performed with the system's power supply shut off.

- Check periodically for oil leaks. To **top-up the oil** proceed as follows:
  - a) Screw in the bleeder screw (fig. 20) and remove the controller from the gate.
  - b) Push the rod right back.
  - c) Set the controller upright and unscrew the cap O (fig. 18).
  - d) Use the same type of oil to top up the level until the motor bearing under the cap "O" is covered.
  - e) Close the cap "O" and mount the controller back onto the gate.
  - f) Remove the bleeder screw.
  - g) Run through 2 complete manoeuvres collecting the excess oil from the bleeder.
- Check the safety elements on the gate and drive unit.
- For any malfunction that remains unsolved, shut off the power to the system and call a qualified specialist (the installer). During a breakdown, use the manual release to allow the gate to be opened and closed by hand.

## 17) TROUBLE SHOOTING

### 17.1) Faulty operation of the gearmotor

- Use a suitable instrument to check if there is a voltage across the gearmotor terminals when an open or close command has been given
- If the motor vibrates but does not turn, this may be due to:
  - the common wire C is wrongly connected (it is always light blue)
  - the drive capacitor is not connected to the two drive terminals
- if the leaf moves in the wrong direction, invert the drive connections of the motor in the control unit **LEAF STOP**: when the operating time set in the control unit is too short, the leaves may not have time to complete their stroke. Slightly raise the operating time in the control unit.

### 17.2) Faulty operation of the electrical accessories

If any of the control and safety components are faulty, this can cause malfunctions or a breakdown of the whole automation.

If the control unit is equipped with a self-diagnostics system, identify the fault.

In case of a fault, it is wise to disconnect each of the components in the automation one at a time, until the one that is causing the fault is found.

After having repaired or replaced it, restore all the components that were disconnected. For details on each component, refer to its specific instruction manual.

**WARNING:** Any malfunction should be corrected immediately by a qualified specialist. When carrying out maintenance operations, the area around the gate should be well marked and barred in order to prevent accidents to people, animals and objects.

#### WARNINGS:

Trouble-free operation of the controller can only be guaranteed if the data given in this manual is respected.

The manufacturer is not liable for damages caused by the failure to respect safety rules, installation recommendations and instructions given in this manual.

## 18) SCRAPPING

**Warning:** This operation should only be carried out by qualified personnel. Materials must be disposed of in conformity with the current regulations.

In case of scrapping, the automation devices do not entail any particular risks or danger. In case of recovered materials, these should be sorted out by type (electrical components, copper, aluminium, plastic etc.).

## 19) DISMANTLING

**Warning:** This operation should only be carried out by qualified personnel. When the automation system is disassembled to be reassembled on another site, proceed as follows:

- Disconnect the power supply and the entire external electrical installation.
- In the case where some of the components cannot be removed or are damaged, they must be replaced.

**The descriptions and illustrations contained in the present manual are not binding. The Company reserves the right to make any alterations deemed appropriate for the technical, manufacturing and commercial improvement of the product, while leaving the essential product features unchanged, at any time and without undertaking to update the present publication.**

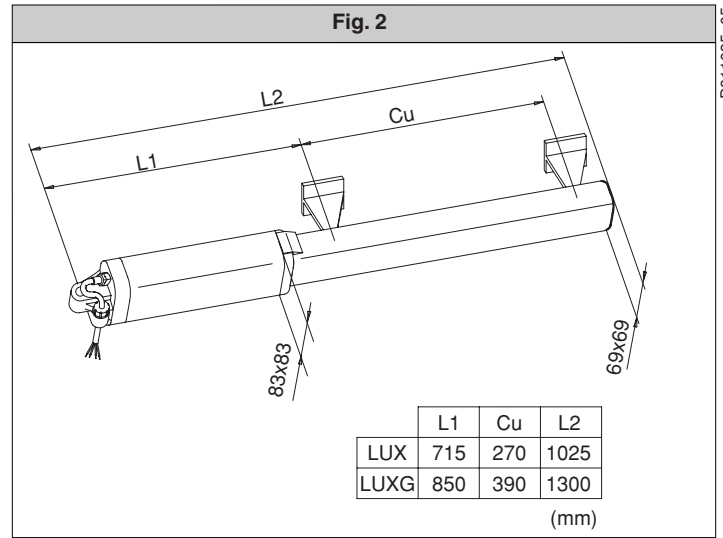
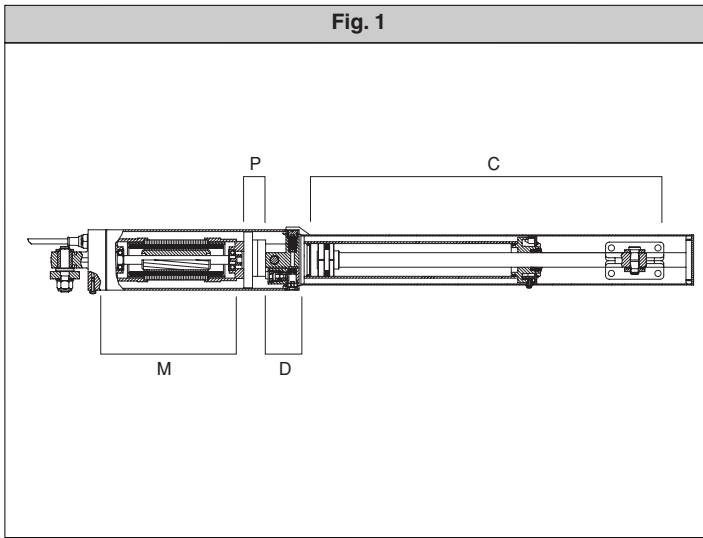

**Fig. 3**

LUX		mm									
b \ a	80	90	100	110	120	135	145	155	165	175	
90						116	108	102	98	94	
100						110	103	98	94	91	
110					123	104	99	94	91		
120					111	99	94	91			
135				111	100	90°					
145				102	94						
155			104	95	90						
165			95	90							
175		95	88								
185	96	88									α°

**Fig. 4**

LUX G - LUX GV											mm
b \ a	95	115	135	155	175	195	215	235	255	275	295
95						128	115	107	102	97	94
115						119	108	102	97	93	90
135					130	111	102	97	93	89	
155					114	103	97	92	88		
175					104	96	91	87			
195					107	96	90°				
215					96	89					
235					96	88					
255	105	96	87								
275	96	85									
295	94										α°

I - Installazione possibile solo con staffa da 110 mm.  
 GB - Installation only to be carried out using a 110 mm bracket.  
 F - Installation possible seulement avec patte de 110 mm.  
 D - Installation nur mit 110 mm - Torflansch möglich.  
 E - Instalación posible solamente con estribo de 110 mm.  
 P - É possível efectuar a instalação somente com uma braçadeira de 110 mm.

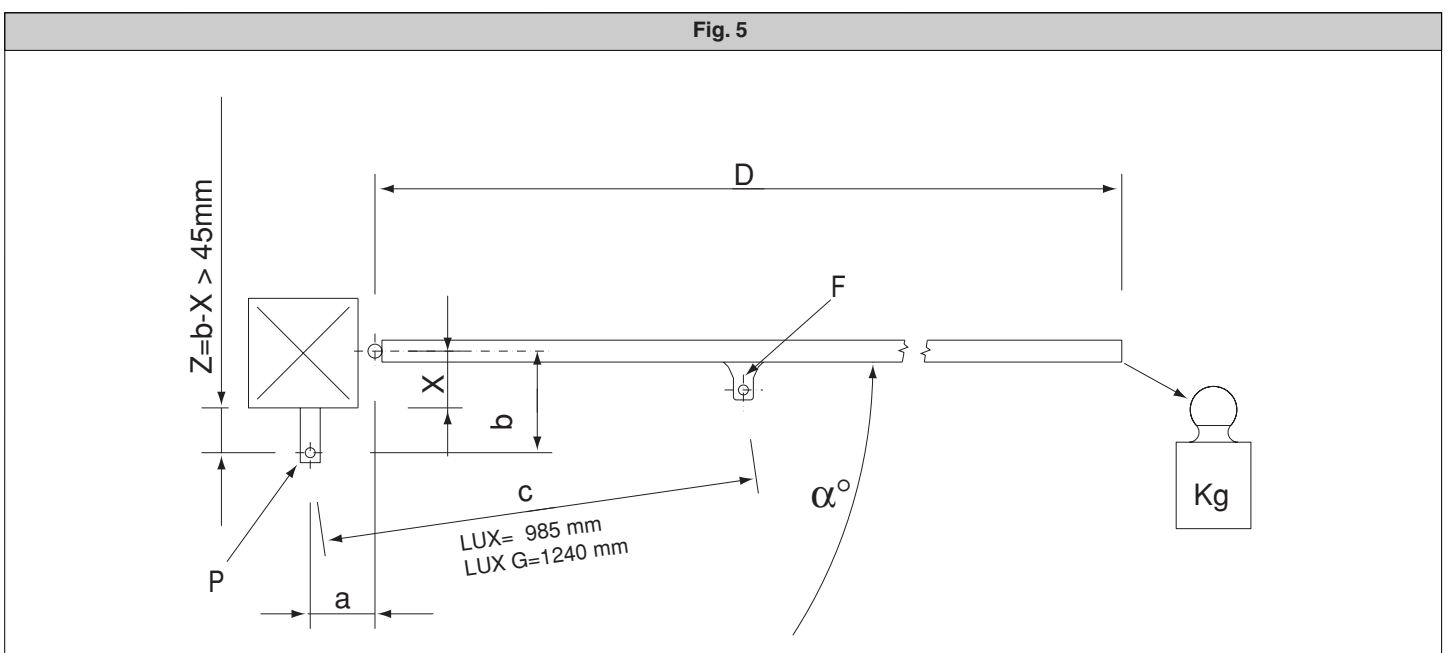

Fig. 6

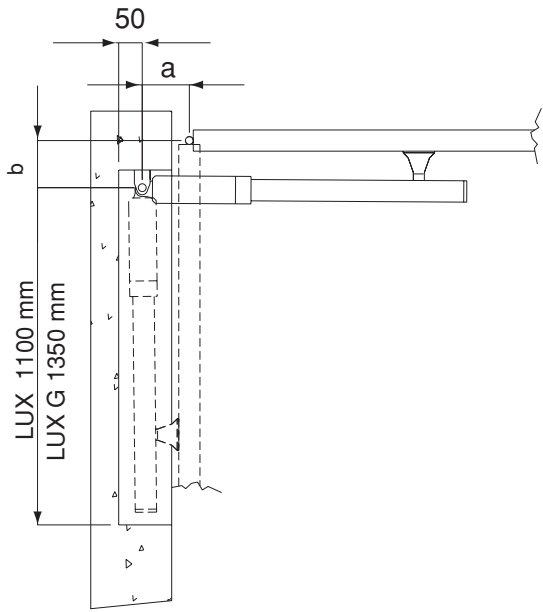

Fig. 7

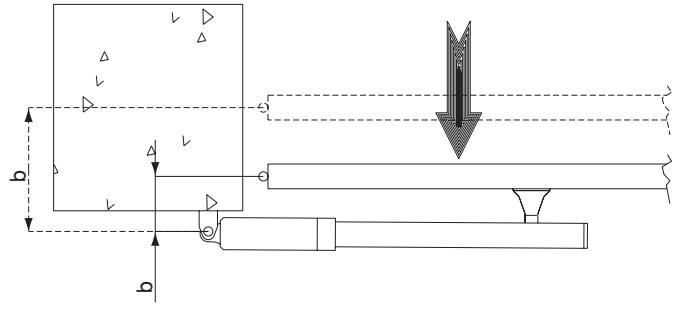

Fig. 8

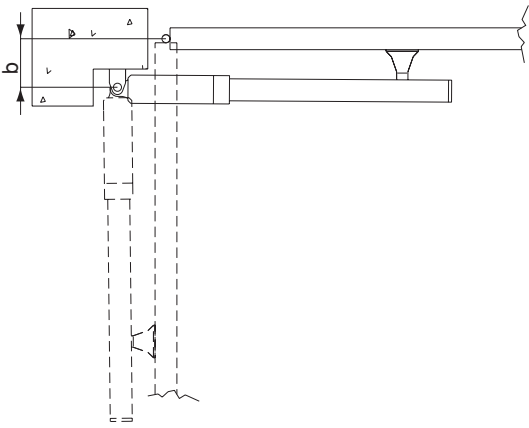

Fig. 9

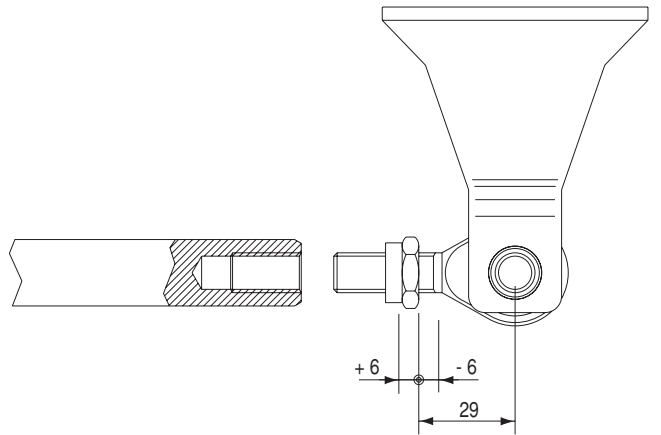
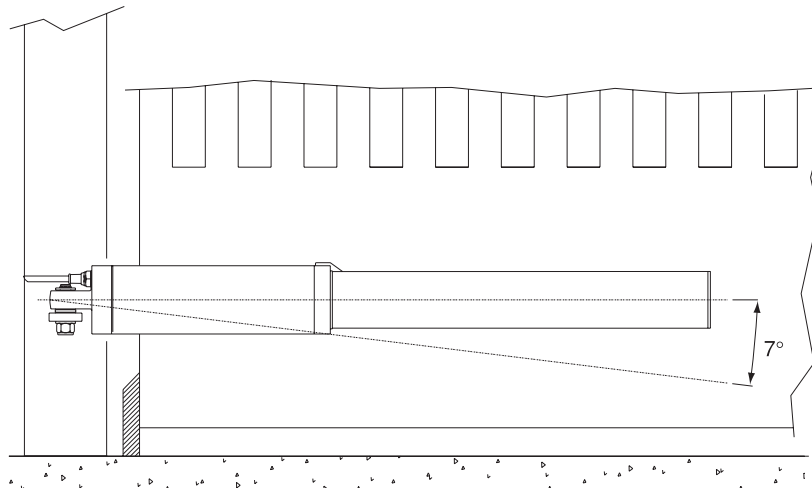
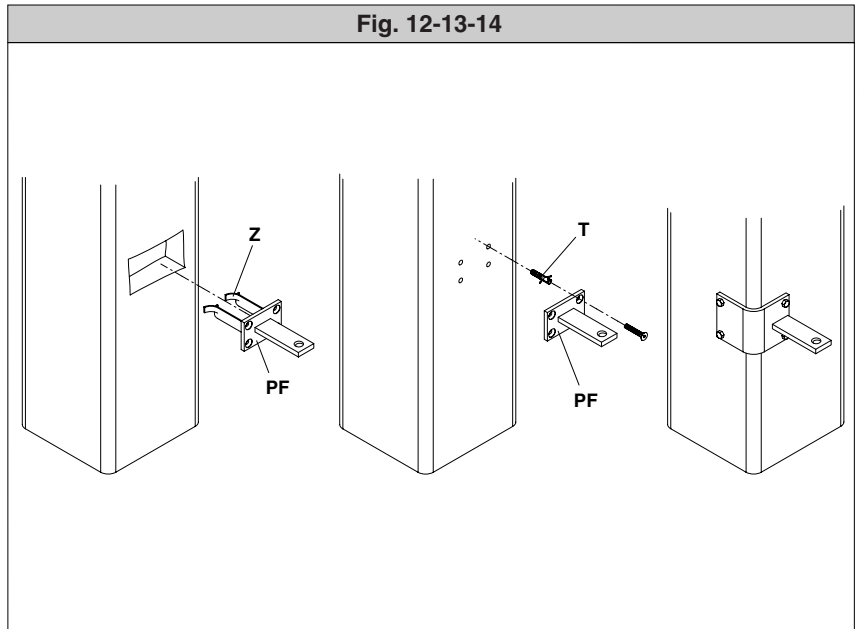
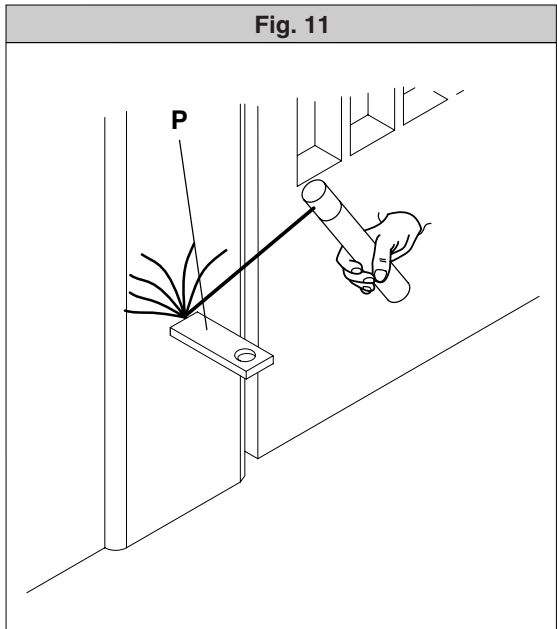
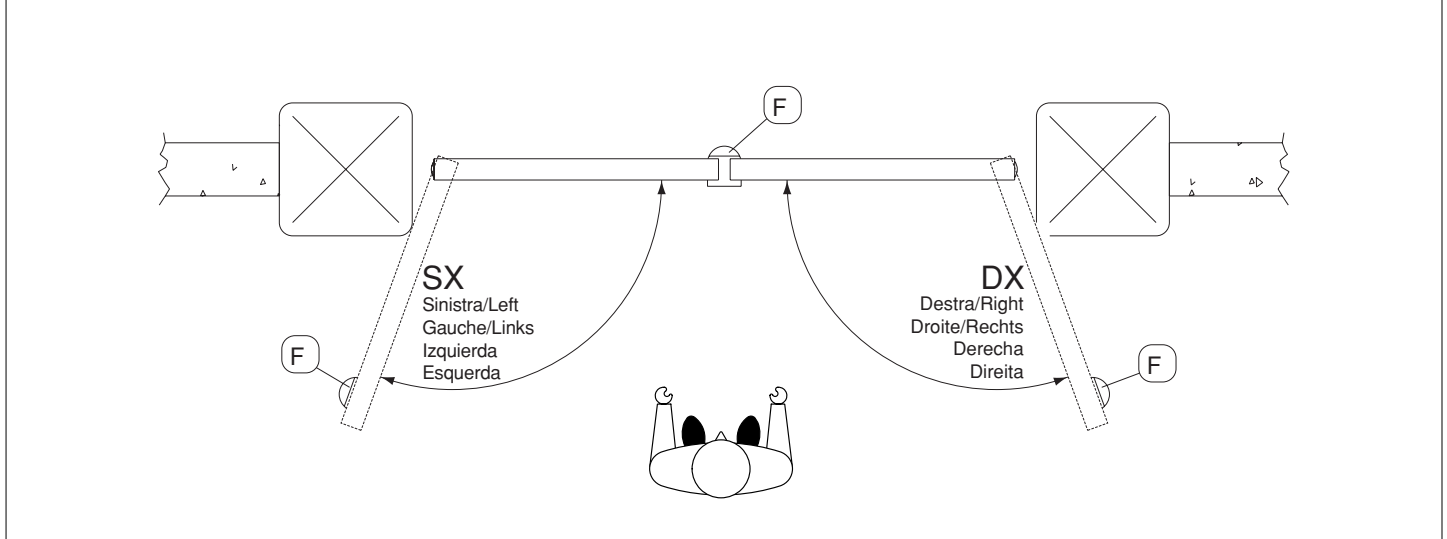

Fig. 10





**Fig. 15**



**Fig. 16**

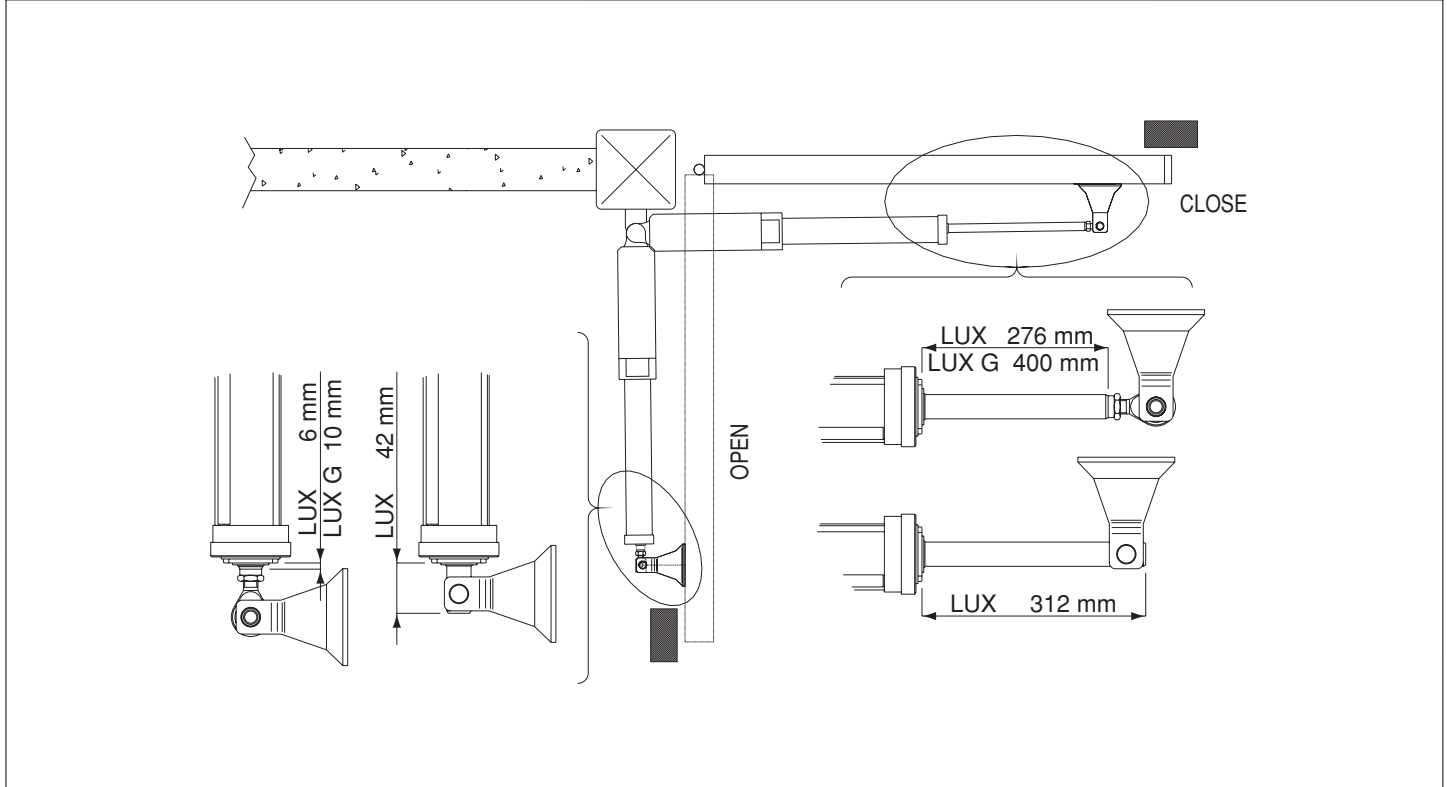

Fig. 17

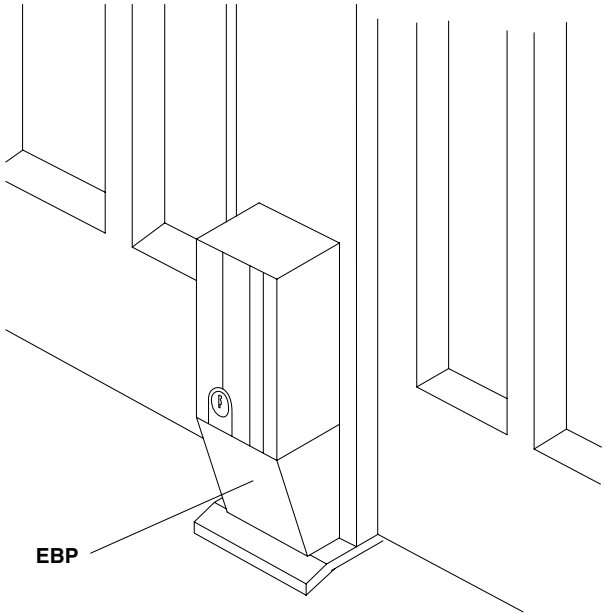

Fig. 18

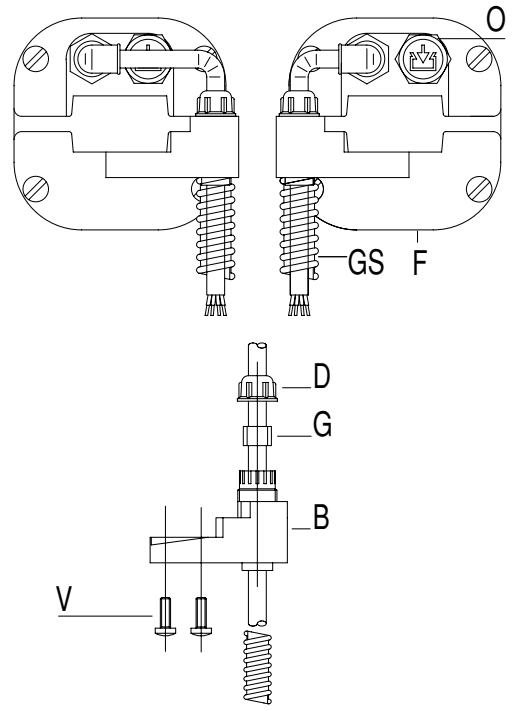

Fig. 19

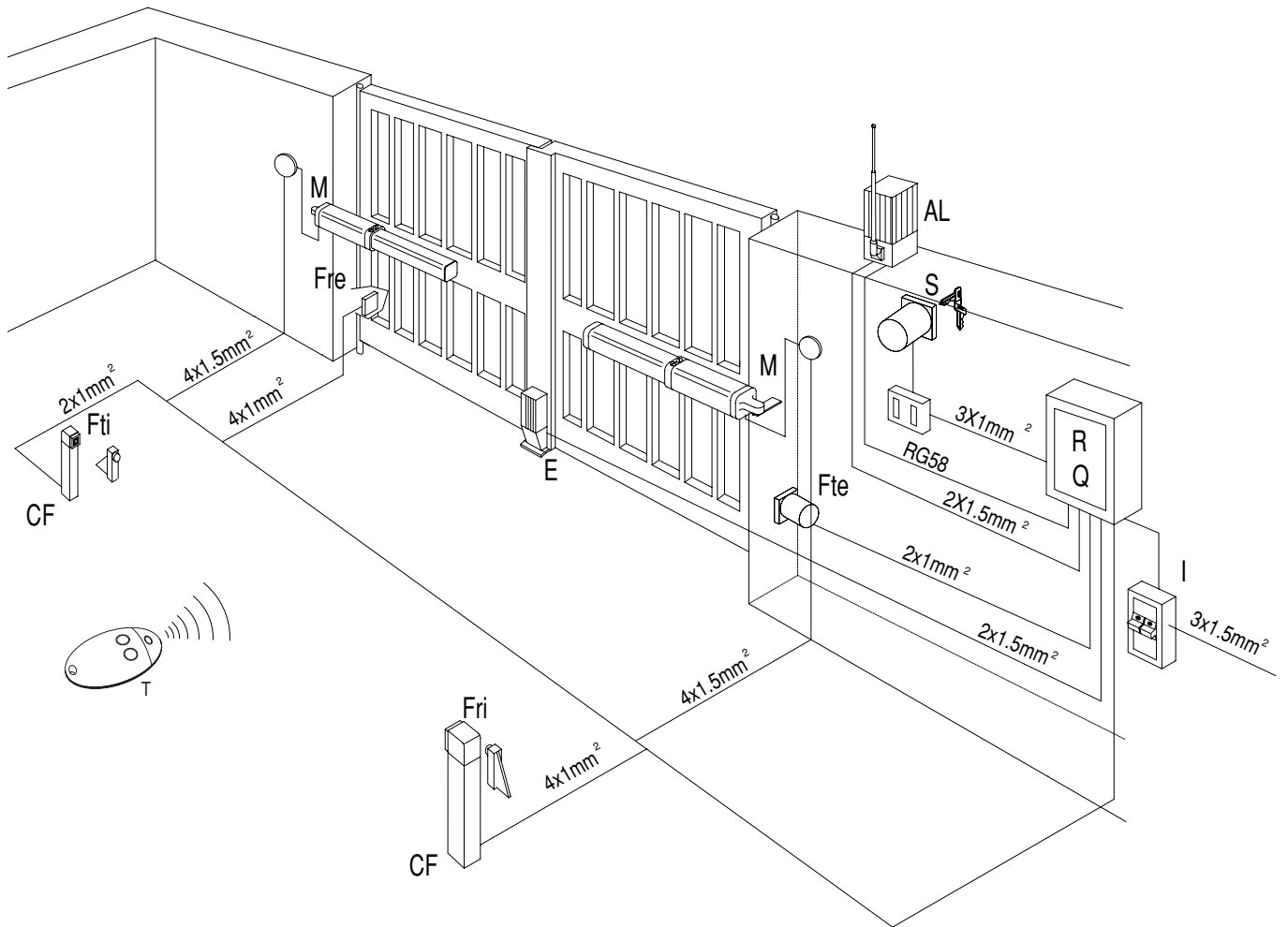



Fig. 20

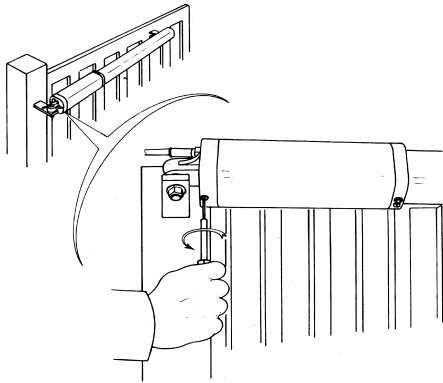

Fig. 21

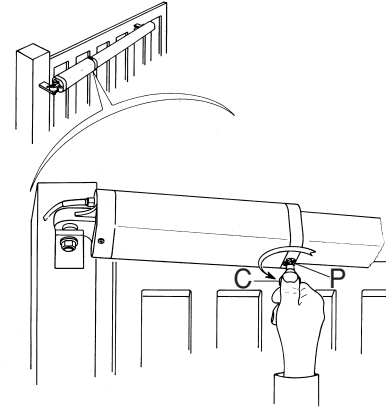

Fig. 22

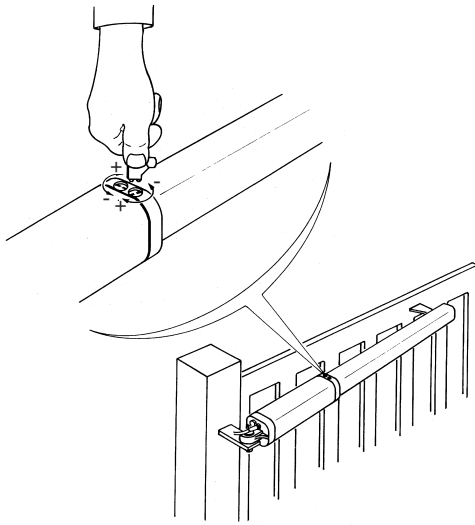

Fig. 24

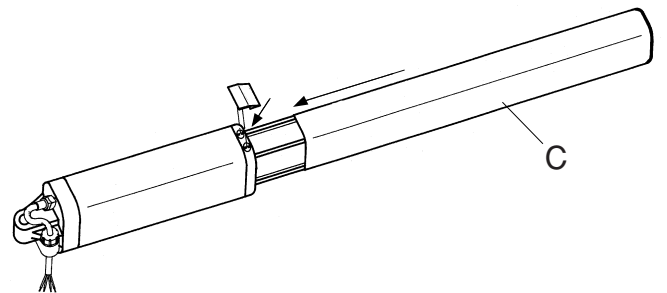
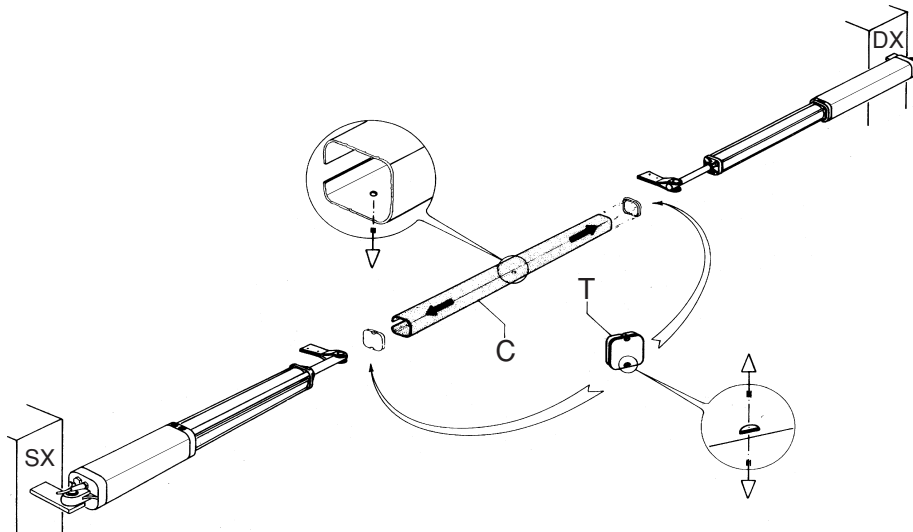

Fig. 23



**BFT S.P.A.**

Via Lago di Vico 44  
36015 Schio (VI) / *Italy*  
Tel. 0039 445.696511 - Fax 0039 445.696522  
www.bft.it - e-mail: sales@bft.it

**BFT TORANTRIEBSSYSTEME GmbH**

Faber-Castell Str. 29  
90522 Oberasbach / *Germany*  
Tel. 0049 911 7660090 - Fax 0049 911 7660099  
e-mail: service@bft-torantriebe.de

**BFT AUTOMATION UK LTD**

Unit 8E, Newby Road  
Industrial Estate Hazel Grove  
Stockport SK7 5DA / *England*  
Tel. 0044 161 4560456 - Fax 0044 161 4569090  
e-mail: info@bft.co.uk

**AUTOMATISMES BFT FRANCE**

13 Bd. E. Michelet  
69008 Lyon / *France*  
Tel. 0033 4 78 76 09 88 - Fax 0033 4 78 76 92 23  
e-mail: infofrance@bft.it

**BFT BENELUX SA**

Rue du commerce 12  
1400 Nivelles / *Belgium*  
Tel. 0032 67/ 55 02 00 - Fax 0032 67/ 55 02 01  
mail: info@bftbenelux.be

**BFT-ADRIA d.o.o.**

Obrovac 39  
51218 Dražice (RIJEKA) / *Croatia*  
Tel. 00385 51 502 640 - Fax 00385 51 502 644  
www.bft.hr - e-mail: info@bft.hr

**BFT Polska Sp. z o.o.**

ul. Szatwiowa 47  
03-167 Warszawa / *Polska*  
Tel. 0048 022 814 12 22 - Fax 0048 022 814 39 18  
www.bft.com.pl - e-mail: biuro@bft.com.pl

**BFT GROUP**

**ITALIBERICA DE AUTOMATISMOS S.L.**  
*España*  
www.bftautomatismos.com

P.I. Palau Nord, Sector F  
C/Cami Can Basa nº 6-8  
08400 GRANOLLERS *Barcelona*  
Telf. +34 93 8614828 - Fax +34 93 8700394  
e-mail: bftbcn@bftautomatismos.com

P.I. Comendador,  
C/ informàtica, Nave 22  
19200 AZUQUECA DE HENARES *Guadalajara*  
Telf. +34 949 26 32 00 - Fax. +34 949 26 24 51  
e-mail: bft@bftautomatismos.com

