

WORKSHOP 2011 DISC BRAKES

MAGNESIUM
Marta SL

Marta SL

Marta



MAGURA

THE PASSION PEOPLE

www.magura.com

Ground contact isn't that important to you. There is (almost), no terrain where a **Freerider** won't go. Tough and stable components are a must have. Here they are.

There are bikers out there for whom uphill is just a means to an end. The downhill fun is having absolute priority for them. With lots of travel and robust components the **Enduros** must cope with technically hairy downhills and bike-park weekends..

You're an all-rounder. You love long and sweeping trails, up as well as down. The optimum mix of light weight and stability is the hall mark of your **AllMountain** components meant for an broad spectrum of use.

Mile after mile over the dusty trails as well as hard fast tarmac. On every ride your bike should be the epitome of uncomplicated - and naturally the parts for your **X-country** adventures shouldn't cost the earth.

Race-orientated means for us the minimum weight that is technically possible. Every gram extra weight can be the decisive factor between winning or losing for you, the **racer maniac**.

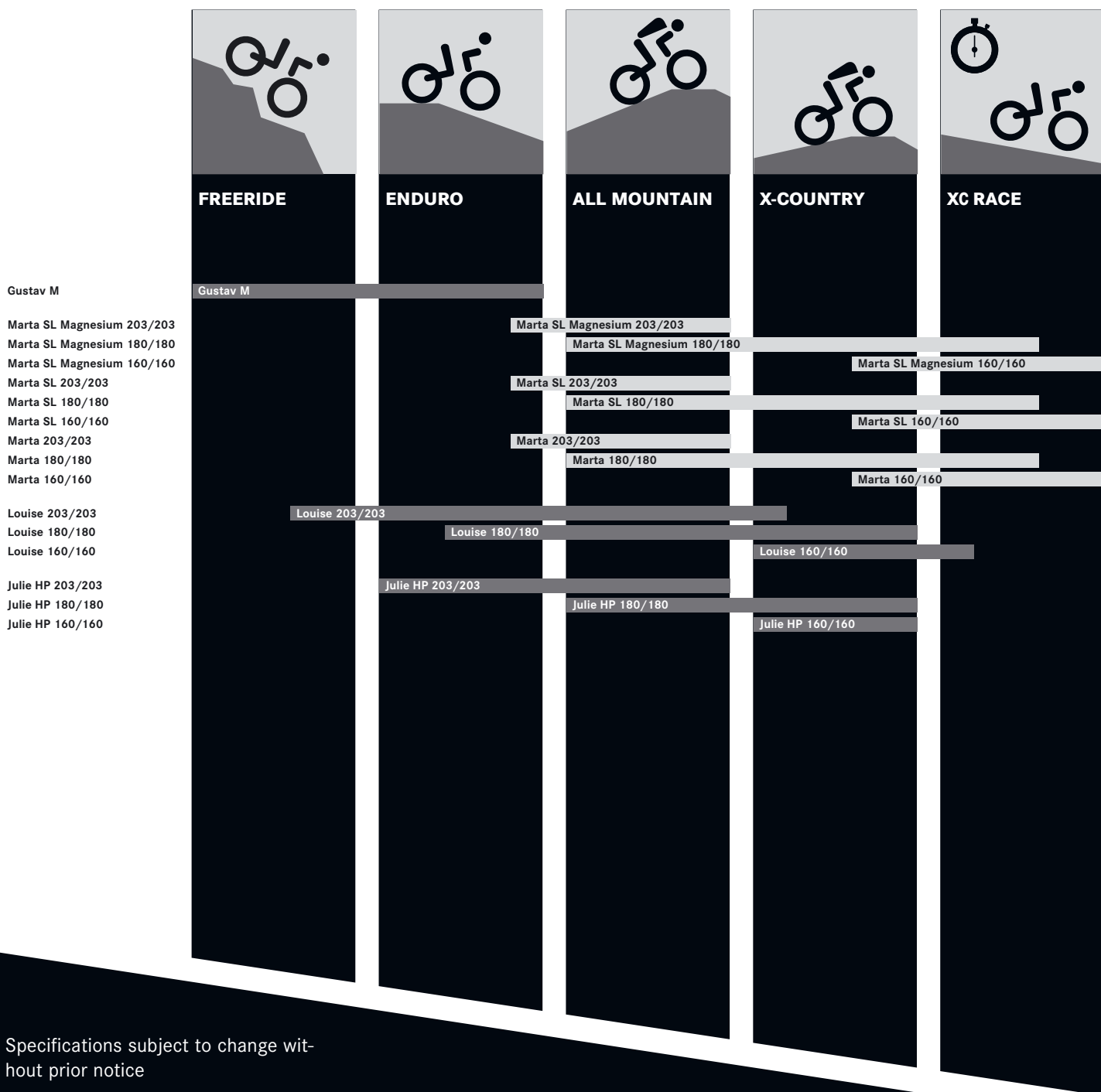

Summary

1. Introduction	3
2. Safety instructions before the first ride	4
3. Safety instructions before every ride	4
4. Transport of the bicycle	5
5. Brake installation	6-9
6. Shortening the hose	10-11
7. Maintenance	12-13
8. Repairs	14
9. Bleeding and Filling	15-16
10. The disc brake wheel	17
11. Trouble Shooting	18
12. Accessories	19
13. Warranty	19
14. Spare parts exploded view	20-21
15. Tuning adaptors for Postmount caliper	22



WARNING:

This symbol means possible danger for your health and even life if you do not follow the instructions given respectively if the necessary safety measures are not followed.

**ATTENTION:**

This symbol warns you of inappropriate handling that might cause serious damage to the material and/or the environment.

**NOTE:**

This symbol gives you additional information about the general handling of the product or gives hints to paragraphs in this manual which have to be read carefully.

1. Welcome to the Passion People!



Brake lever (master cylinder)
MAGURA Marta SL Magnesium

Congratulations! You have purchased a fully hydraulic MAGURA disc brake proudly „Made in Germany“. You will be amazed at the awesome braking power and the minimum amount of maintenance that is necessary on our stoppers. Good to know that you are not alone, millions of riders worldwide rely on them and every day our numbers are increasing.



Brake caliper and rotor
MAGURA Marta SL Magnesium

On the fully hydraulic MAGURA disc brake system Marta, Marta SL and Marta SL Magnesium the braking force is transmitted to the braking surface by a mineral oil column. The movement of the lever blade moves a piston, which is integrated in the brake lever (master cylinder). The piston pushes the mineral oil column through the brake hose in the direction of the brake caliper, where two pistons, on which the brake pads are fixed, are pushed out. The friction between the brake pads and the rotor slows down the bicycle and causes both the rotor and the brake caliper to heat up.

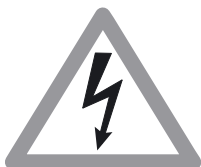

Never touch either the rotor or the brake caliper after long braking as this may cause serious burns

You will be pleased to find out that the MAGURA Marta disc brake offers a superior braking power even with little hand force applied, no matter what the weather conditions should be. Particularly in wet weather conditions disc brakes are much more responsive than rim brakes and transmit their enormous power immediately after activating the brake lever.

Disc brakes don't wear your rims down. However if they have been mounted incorrectly they might cause a squealing noise during braking, mainly during wet weather conditions.

This manual contains important information about the safe installation, operation and maintenance of your MAGURA disc brake. We urge you to read it carefully, become familiar with its contents and follow our recommendations to help make your new braking experience enjoyable and trouble free.



All steps will be explained on the Marta model. The Marta SL and Marta SL Magnesium are technically identical, with the exception of the carbon lever blades (which are compatible with Marta).

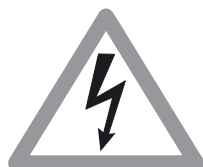

Although the Marta disc brake system is relatively simple you should not overestimate your technical skills! We therefore advise you to leave the following operations to a trained technician of a professional bike shop.

Should there be any further questions or problems we warmly recommend that you visit our website www.magura.com where you will always find the newest and hottest tips about all our products. On magura.com you can also download this manual in a convenient A4 format and get online help around the clock for free. Stay tuned with the Passion People!

Thank you for your confidence in our products, enjoy your ride and your new MAGURA disc stoppers!

Happy trails!

2. Before the first ride

1. Are you already familiar with hydraulic disc brakes? Our brakes might be much more powerful than the stoppers on which you relied so far. Take your bicycle to a safe area to learn the proper braking technique and operation of your new brakes and your bike.

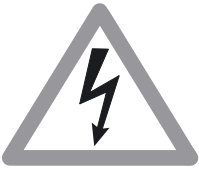

2. Check whether you activate the front brake with the brake lever, which you are used to braking on the front. If ever this is not the case you will have to train your new setup because any unintended braking might cause an accident with possible heavy bodily injury! Change the hose connection by a trained technician in case of any doubts.

For further hints concerning swapping of the brake hose see page 10 onwards.

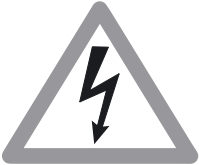

3. New brakes and new rotors or brake pads must always be run in by braking at least 30 times from a speed of 30 km/h to achieve the maximum brake power. Take your bike to a safe place to run in the brake.

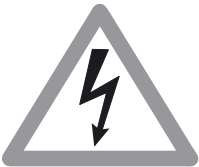

4. While riding in extreme riding conditions (total weight of bike plus rider over 100 kg and/ or a gradient of more than 15 %) always use both brakes simultaneously to slow your bike down.

5. Use the brakes according to the user chart on page 2 of this manual. Any misuse might cause serious accidents with fatal injuries to yourself and others!

6. Are you familiar with the other components on your bike such as gears, clipless pedals and suspension units? Always practise using your bike in a safe area to improve your handling abilities before using it on the road. Consult the user's manual of your bike to learn more about this.

7. For your own safety always wear a helmet when you ride a bicycle. Make sure as well that you wear the suitable clothing and footwear.

3. Before every ride

always check carefully the following points:

1. Always make sure that the quick release skewers of your wheels and seat post are correctly mounted and closed.

incorrectly installed quick release skewers might cause the fixed items to become loose. Serious accidents with severe injury may result!!



2. Always make sure that the brake lever pressure is o.k. by pulling the lever blade and ensuring that full braking performance is achieved before the lever blade touches the handlebars. If this is not the case, pull the lever blade several times (pump) until the brake pads touch the rotor.

Changing pressure points during a ride might be the result of having air in the brake system.

See hints about filling and bleeding from on pages 15/16.

3. Always make sure that the brake system does not have any leaks by activating the lever blade, holding it and checking the hose connections and reservoir cover for eventual leaks. (Also see page 11)

4. Always protect your rotors and brake pads from oil and lubricants (e.g. by lubricating your chain). Avoid detergents and soap on the brake pads. **Contaminating the pads with oil and lubricants will cause a permanent loss of braking power. Such contaminated pads can no longer be used and should be replaced!** Clean a contaminated rotor with dishwater or alcohol.

See further hints about changing the brake pads on pages 12- 13.

5. Release your brake lever and check whether your wheel moves freely and without drag. Check eventually whether the wheels are correctly mounted and if the quick release skewers are tightened sufficiently. (Also see page 9)

6. Are your tires in a good condition, and have they enough air pressure? Test this with your fingers. Lift up your bike and turn the wheels of your bike. An insufficient rotation might be due to damaged tires, broken axles and/ or broken spokes.

7. Pick up your bike and let it drop from a moderate height. Be careful in case of any rattling noises. If any are heard check the bearings and all screwed connections.

8. Always follow the instructions given in the owner's manual of your bicycle.

Never use your bicycle if any of the points mentioned above relate to your bicycle! Consult a professional bike mechanic if you feel unsure. A faulty bicycle might cause serious accidents with possible fatal injuries of the rider!

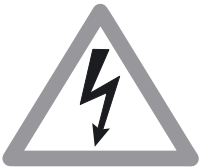

4. Transport of the bicycle

In case of a disc brake equipped bicycle you should always keep in mind the following points:

Never activate the lever blade without the brake pads in place and the wheels mounted. In case this should have happened see page 10 of this manual.



Never throw away the transport device, which has been delivered with the brake. Always clip it between the brake pads whenever the wheel is removed (e.g. transport of the bike).

Always carefully remove the wheels. Make sure that the rotors are not damaged, deformed or contaminated with lubricants.



If the bike is transported upside-down squeeze before (with mounted wheel or transport device!) the lever blade, hold pressure and fix the blade in this position with a rubber band or a cable tie.

During transport in an aircraft you can leave your brake as it is, e.g. you do not have to empty it.

5. Brake Installation

1. Tools for installation (+maintenance)

Allen key 2*, (2,5, 3) and 5
transport/mounting device*
sharp knife
8 mm open end wrench
flat blade screw driver
Torx T25 key*
(Torx T7 key)

(*delivered with the brake)



Always insert the allen and torx keys completely to avoid damaging the bolt heads.

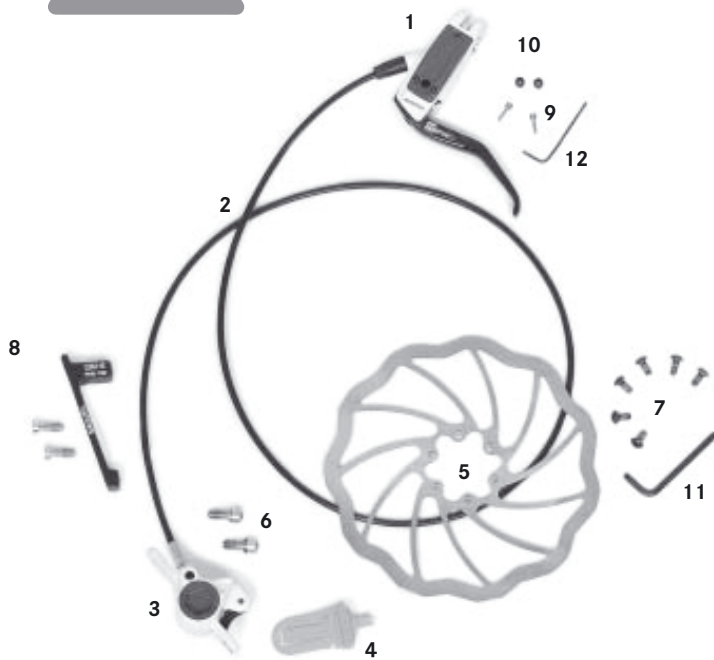

Unpack your Marta disc brake:

1. brake lever (master cylinder) connected through the
 2. brake hose with the
 3. brake caliper with transport device
- ATTENTION:**
4. remove transport device only shortly before installation of the wheel!
 5. rotor
 6. fitting bolts for caliper Allen key 5 (2 pieces)
 7. fitting bolts for rotor Torx key T25 (6 pieces)
 8. adaptor with fitting bolts (depending on model)
 9. hose inserts (2 pieces)
 10. olives (2 pieces)
 11. Torx T25 key
 12. Allen key 2

Specifications modifying and improving this product are subject to change without prior notice.

The brake levers and calipers of the different MAGURA disc brake models are

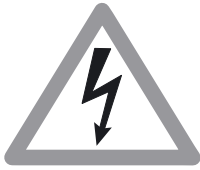

completely different and not compatible! Never mix and match parts from the different models! Any misuse might cause serious accidents!

MAGURA manufacture these braking systems according to the valid standards and make many rigorous product tests. Because of the large variety of forks and frames available on the market it is impossible for MAGURA to test all possible combinations. If you mount any of our brake systems always make sure that the brakes are in conformity with the bicycle.



Disc brake calipers can generate a lot of heat during extreme riding conditions. The resulting heat transfer from the caliper to the fork and/ or frame can have a negative influence on the mechanical characteristics of both the fork and/ or the frame.

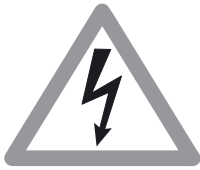

Insufficient heat transfer from the brake caliper to the frame and the fork, caused by fork and or frame components having low heat transfer characteristics (e.g. carbon rear triangles) can cause the brake to overheat, with the possibility of a total failure of the brake system. This can cause serious personal injury to yourself and/ or others.

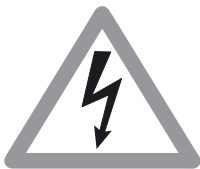

With respect to product liability we remind all our users that any manufacturer (also: bike mechanic or end consumer!) is responsible for the correct function of the complete bicycle in this context. Improper combinations and insufficient installation can cause damage and serious accidents!



2. Mount the brake lever to the handlebar with a 5 mm allen key. **Tightening torque 4 Nm/ 34 in.lbs**

Hint: Tighten the brake lever so that it can still rotate around the handlebar in case of a crash. This old motocross trick will reduce considerably the risk of a damaged brake lever.



The MAGURA disc brake Marta is compatible with frames and forks which meet the International Standard (IS) and for Postmount (PM) mounts. Depending on the mounting standard and/or rotor size adaptors are used for a proper installation (cf. table on page 21). Never mount the brakes with adapters or brackets from other manufacturers! All warranty will be void in case of any misuse! Use only direct mounting parts from MAGURA or the frame or fork's manufacturer!

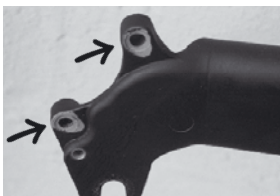

Make sure that the caliper fitting eyelets on your frame or fork are free of any paint, powder coating or burrs. (arrows). If this is not the case you should contact your dealer who will be able to clean the surfaces providing an absolutely flat/even mounting surface with the help of the MAGURA Gnann-o-mat disc optimizer tool (also see page 9).

ATTENTION: The treatment of suspension fork lower legs made of magnesium might be dangerous because of corrosion! Always follow the safety instructions given by the respective manufacturer! Always make sure after having treated the disc brake mounts that these are protected against corrosion by using an appropriate protective paint.



3. Mounting on IS mounts:

Mount the adaptor onto the fork or the frame. Use a 5 mm allen key. Please follow carefully the mounting instructions that come with the respective adaptor! If you use a thru-axle hub on the front you might have to use thicker 3 mm spacers (depending on fork model). These are available separately (code: 0720 829).

Tightening torque: 6 Nm/ 51 in.lbs.



4. Caliper installation: Mount the caliper with MOUNTED wheel and rotor onto the adaptor. For a better understanding the mounted wheel is not shown on this picture. Do not tighten the caliper bolts yet! Squeeze the lever blade and keep the pressure. Tighten now the bolts. **Tightening torque: 6 Nm/ 51 in.lbs.**



5. Mount the rotor with the 6 Torx T25 bolts onto the hub. Watch out for the correct rotation direction of the rotor (laser arrow). Use only new original bolts or thread lock if you use old bolts. **Tighten the bolts in a crossed pattern! Tightening torque: 4 Nm/ 34 in.lbs.**

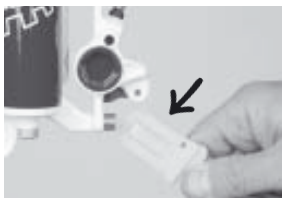

6. The transport device prevents the brake pads from being pushed out too far by unintended lever squeeze when the wheel is removed. It is impossible then to install the wheel with the rotor. So never throw away the transport device but keep it and always clip it between the brake pads as shown when the wheel is removed.

Install the wheel by positioning the rotor between the brake pads and fixing the wheel in the dropouts. Close the quick release of your wheel **which you should mount on the opposite side of the brake caliper** and tighten it sufficiently.



7. Squeeze the lever blade several times (pump) to push the pads to their proper position until the lever feel becomes very firm. Tighten now the caliper fitting bolts. **Tightening torque: 6 Nm/ 51 in.lbs.**



8. Mounting on PM mounts:

For Postmount 6" installation in combination with a 160mm rotor, Postmount 7" with 180mm rotor or Postmount 8" with a 203mm rotor on the front you do not need an adaptor. Mount the caliper **DIRECTLY** onto the fork with MOUNTED wheel and rotor. For a better understanding the mounted wheel is not shown on this picture. Do not tighten the caliper bolts yet! Squeeze the lever blade and keep the pressure. Tighten now the bolts. **Tightening torque: 6 Nm/ 51 in.lbs. Further mounting alternatives cf. page 21 of this manual.**



Install the wheel by positioning the rotor between the brake pads and fixing the wheel in the dropouts. Close the quick release of your wheel **which you should mount on the opposite side of the brake caliper** and tighten it sufficiently. As to thru-axle hubs or wheels consult the manual of the respective fork manufacturer.

Squeeze the lever blade several times (pump) to push the pads to their proper position until the lever feel becomes very firm.



Do not worry when you hear friction between rotor and pads. A slight drag is normal on disc brakes with automatic pad wear adjustment during the break-in period. This drag will disappear after a while. The reason for this is that the brake pads find their optimum working position towards the rotor, only after a slight wear during the break-in period. Slight drag might also happen after a brake pad change or in case of an incorrectly installed wheel.

In the case of a **constantly dragging** disc brake causing noise your frame or fork could be miss-aligned. In such a case you should contact your dealer who can care to this with the MAGURA Gnann-o-mat disc optimizer for a totally even surface of the disc brake mounts. These are absolutely necessary for a drag free function of your brake.

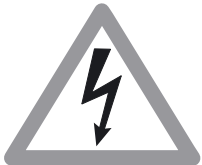

New brakes and/or new rotors or brake pads must always be run in by braking at least 30 times from a speed of 30 km/h to achieve the maximum brake power. Take your bike to a safe place to run in the brake.



Reach adjust is done with a 2,5 mm Allen key. Turning key clockwise: lever blade moves away from the handlebar, turning counterclockwise: blade moves to the handlebar.

6. Shorten the hose

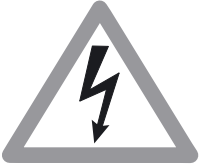

Marta is a high-pressure system and comes with a reinforced hose, the „MAGURA Disc Tube“ which will show this label. The Disc Tube needs an additional insert for a proper fitting. Never mix and match either the hoses or other parts from the other MAGURA disc brake models. Any misuse might cause serious accidents!

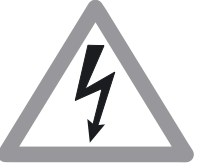

Never touch either the rotor or the brake caliper after long braking as this may cause serious burns.



1. Remove the wheel so that you have free access to the brake caliper. Push back both brake pads by putting the transport device or a flat blade screwdriver into the gap. Move the screwdriver **slowly** back and forth until both caliper pistons are fully retracted and flush with caliper body.



Never push back the pistons without the brake pads mounted! Open the brake system only after having fully pushed back the brake pads.



2. Loosen the brake lever clamping screw with a 5 mm allen key. Turn the brake lever and ensure that the reservoir is horizontal.



3. Slide the hose protection. Unscrew the sleeve nut on the brake lever with an 8 mm open-end wrench and pull the hose out **carefully**. **Hold the hose carefully to avoid any loss of oil! Do not squeeze the lever blade with the system open!**



4. Put the hose on a workbench and shorten it with a sharp knife. The best tool is the MAGURA cutter. **Do not use saws or pliers!**



Hold the hose carefully so that it cannot snap away (arrow)! Cut the hose squarely! The sleeve nut can be re-used. The olive and the insert cannot be reused and must be replaced!

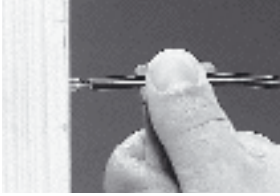

5. Press manually a **new** insert into the hose until it is **fully seated**. Clamp the hose into the groove of the mounting device as shown...



6. ...or clamp the mounting device as shown into a vice and hammer the insert **carefully** into the hose.



7. Slide on the sleeve nut and a **new** olive onto the hose. Push the hose with the sleeve nut and the new olive **fully** into the brake lever and tighten the sleeve nut with an 8mm open-end wrench. **Tightening torque: 4 Nm/ 34 in.lbs.**



8. Always check for correct installation by pulling on the hose. Make sure that the system has no leaks. Squeeze the lever blade, hold pressure and check hose connections and the reservoir cover for eventual leaks.

Squeeze the lever blade several times (pump) to push the pads to their proper position until the lever feel becomes very firm. If you cannot realize this, bleed the brake (see page 15 onwards).

7. Maintenance, brake pad change

Brake Oil: MAGURA disc brakes use as transmission medium low viscosity mineral oil, the biodegradable MAGURA ROYAL BLOOD. Contrary to DOT brake fluid the MAGURA ROYAL BLOOD does not irritate human skin or strip the paint of your frame. Moreover it does not absorb water like DOT and does not have to be changed regularly. What sounds unbelievable is a fact: you can use your brakes over years without having to touch them (except brake pad check and change!)

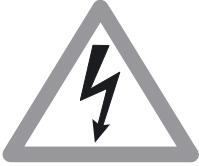

Always make sure that the brake system does not have any leaks by activating the lever blade, holding it and checking the hose connections and reservoir cover for eventual leaks. Consult a trained technician in case of leaks. Leaks cause poor braking performance with possible serious accidents!

As to hints about repairs of the hose see page 14 onwards..

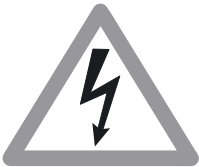

Brake pad wear: The brake pads are subject to wear due to friction between rotor and pads. The Marta disc brake features a fully automatic pad wear adjustment. Regularly check the thickness of your brake pads and replace them, if necessary!

Control and replacement of the brake pads

Never touch either the rotor or the brake caliper after long braking as this may cause serious burns.

Control of pads.



Squeeze the lever blade with the wheel mounted **and hold pressure.**

Hint: Use eventually a rubber band or a cable tie for this.



Check out whether the “finger” of the transport device fits in-between the “ears” of the brake pads. **On the picture on the left this is NOT the case, the pads must be changed! Minimum thickness of pads including holder is 2,5 mm. Change always both pads simultaneously!**



Here the “finger” of the transport device fits between the “ears” of the brake pads. The pads are still o.k. **Remember: the lever has to be pulled during this procedure!**

Pad replacement.

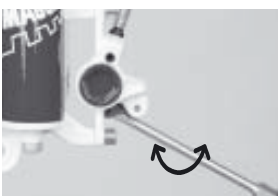

1. Remove the wheel so that you have free access to the brake caliper. Push both brake pads back by putting the transport device or a flat blade screwdriver into the gap. Move the screwdriver **slowly** back and forth until both caliper pistons are fully retracted and flush with caliper body.

Never push back the pistons without the brake pads mounted!



2. Remove the brake pad fitting screw with a 2 mm allen key.



3. Pull out the brake pads. Clean the pads with a dry rag that is free of oil and grease.



**Never push back the pistons without the brake pads mounted!
Never squeeze the lever blade without the brake pads in place and the wheel mounted! If this happened by accident push back the pistons with mounted brake pads by using the transport device or a flat blade screwdriver.**

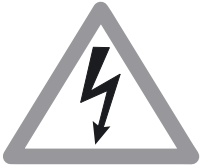

Use only genuine MAGURA brake pads! MAGURA cannot guarantee a correct function of the brake if you use brake pads from other manufacturers, which were not tested. Using other pads might cause poor braking and serious injury! All warranty claims will be void in case of misuse!

4. Clean on the occasion of the brake pad change the brake body with a clean rag.



5. Mount the new brake pads. Make sure that the friction side of the new brake pads points towards the rotor **Tightening torque of the fitting screw: 1 Nm/ 9 in.lbs. Check after installation the correct fitting of the pads by pulling them.**

6. Check, whether the pistons are fully pushed back and whether the pads are flush with the caliper body. Push the brake pads back with the transport device or a flat blade screwdriver as described on page 12. Re-install the wheel and check for a correctly tightened quick release skewer of the wheel **that should be mounted on the opposite side of the caliper.**



7. Squeeze the lever blade several times (pump) to push the pads to their proper position until the lever feel becomes very firm.

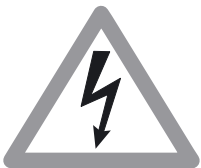

**New brakes and/or new rotors or brake pads must always be run in by braking at least 30 times from a speed of 30 km/h to achieve the maximum brake power. Take your bike to a safe place to run in the brake.
Never contaminate brake pads with oil or grease this causing permanent loss of brake power! Contaminated pads are definitely killed and must be replaced!**

8. Repairs



Disc brake service kit (code: 0721 294)
Don't panic if the hose snaps! With the disc brake service kit and a separately available spare hose (see spare parts pages 21/22), this can be repaired easily.

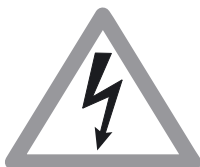

The Marta is a high-pressure system and comes with a reinforced hose, the „MAGURA Disc Tube“ wearing also this imprint. The Disc Tube needs an additional insert for a proper fitting. Never mix and match either the hoses or other parts from the other MAGURA disc brake models! Any misuse might cause serious accidents!

1. Remove the damaged hose from both the brake lever and the caliper. Cut off the barbed adapter (caliper connection) with a sharp knife. Slide both the sleeve nut and hose protector on the other side. All mentioned parts can be re-used. Throw away the damaged hose.

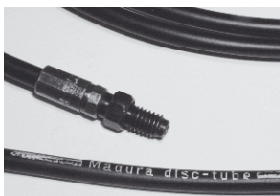

2. **Prepare a new hose:** Use only the reinforced „MAGURA Disc Tube“ hose! One end this hose comes with a pressed fitting, which has to be screwed into the caliper as described above. **Tightening torque: 6 Nm/ 51 in.lbs.**

Never shorten this hose at the end with the pressed fitting! You could no longer use the hose then.



3. Tighten the prepared end of the new hose onto the caliper.
Tightening torque: 6 Nm/ 51 in.lbs.

4. Mount the brake hose as described in chapter 6.



After the installation of a new hose you will always have to refill the brake. The following chapter 9 describes how the filling has to be done.



5. The new Marta is also compatible with the 90° hose fitting. Mounting as shown, also see page 20.

9. Filling and bleeding a brake



Brake oil: MAGURA disc brakes use as transmission medium low viscosity mineral oil, the biodegradable MAGURA ROYAL BLOOD. Contrary to DOT brake liquid the MAGURA ROYAL BLOOD does not irritate human skin or strip the paint of your frame. Moreover it does not absorb water like DOT and does not have to be changed regularly. What sounds unbelievable is a fact: you can use your brakes over years without having to touch them (except brake pad change!)



1. Loosen slightly the clamping screw of the brake lever with a 5 mm allen key and turn the brake lever **so that the reservoir is approximately 15° upwards from the horizontal position**. Slightly tighten the clamp screw in that position.



2. For filling and bleeding a MAGURA disc brake you will need the disc brake service kit including all necessary tools.

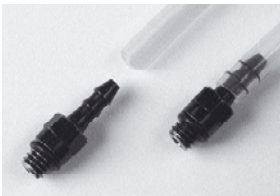

3. Prepare the transparent filler tube by pushing in by hand the M6 barbed fitting on which you have mounted an O-ring before. Put the other end of the filler tube on the syringe and fill the syringe **completely** with MAGURA ROYAL BLOOD mineral oil. Fill the syringe completely and make sure that **there are no air bubbles inside**. Turn the syringe eventually to push out air bubbles.



4. Remove the brake pads as described on page 12 and slide the YELLOW transport device as shown **with its THICK END** between the caliper pistons. Squeeze slightly the lever blade (pump) to tighten the transport device.



5. Fix the caliper so that the hose connection is at the highest point of the caliper (hose has to be positioned vertically!). It might be necessary that you have to unscrew the lower caliper fitting bolt and to fix the caliper to realize this properly (e.g. on rearbrakes!) Unscrew bleeding screw with a 3mm Allen key. Screw in the prepared syringe and tighten it by hand.



Place now a rag, which has to be free of oil or lubricants around the reservoir and, more important, around the brake caliper. Care for a clean working environment! No dirt or particles may come into the brake system!



6. Remove **ONLY** the bleed screw of the reservoir with a 2,5mm Allen key. The reservoir cover and the membrane underneath remain on the brake lever!



7. Put the second syringe of the service kit **WITHOUT PLUNGER** into the opened drill of the reservoir cover. Push oil from the brake caliper upwards until the oil column arrives in the syringe on the reservoir. You will see air bubbles now.



8. Now suck the oil carefully back with the filling syringe on the brake caliper. Make sure that there is always enough oil in the reservoir syringe when you suck back the oil with the filling syringe! You will see air bubbles again.



9. Actuate in addition **CAREFULLY** the lever blade to chase tiny air bubbles that might hide within the system. The job is done when no air bubbles can be seen after having followed the steps above several times.



10. **Before you remove the syringe on the reservoir make sure that there is only a small quantity of oil inside.** Place a rag around the brake lever and the caliper thus preventing overflowing oil from dropping down and contaminating and killing the brake pads. Remove the syringe and close the end that was inserted into the reservoir quickly with your finger. Empty the remaining content of the syringe into a container.



11. Close the drill with the bleedscrew. **Tightening torque: 1 Nm/ 9 in.lbs.** That's it!



12. Remove the filling syringe and screw in the 5mm allen bleed screw. **Tightening torque: 2,5 Nm/ 22 in.lbs.** Re-install the brake pads and the wheel.

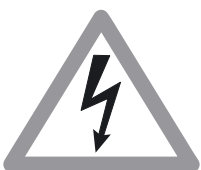

Always pull the lever blade several times (pump) until the brake pads touch the rotor. Always check for correct installation by activating the lever blade and checking for eventual leaks. Never contaminate brake pads with oil or grease this causing permanent loss of brake power! Contaminated pads are definitely killed and **MUST** be replaced! A contaminated rotor can be cleaned with MAGURA brake cleaner, warm dishwater or alcohol.

10. The disc brake wheel

The XC disc brake wheel

There already exists enough literature concerning wheels, so just a few tips how a well-built X-country disc brake wheel has to be.



Use spokes with a diameter of 2 mm (arc) / 1,8 mm which you cross three times.

No radial lacing with disc brake wheels!

Head-inside-spokes (=arc-outside-spokes have to be pulled, i.e. these spokes point forward on the front wheel; on the back wheel these spokes point forward on the rotor side and backwards on the drive side. All spokes have to be stressed equally and high.

Mount the quick release of the wheel on the opposite side of the caliper!

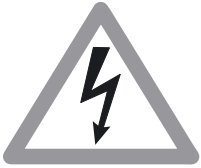

Never use ultra lightweight quick releases with titanium or aluminum axles for your wheel sets in combination with a disc brake. You will not be in a position to realize the necessary tightening torque!

11. Trouble Shooting

problem	reason	solution
not enough brake power no pressure point	brake was not run it	
	oil/ lubricants on rotor and/ or pads	break in the brake (page 4)
	air in the system leaking systems	clean the rotor with warm dishwater or alcohol replace contaminated brake pads bleeding the brake (page15) correct transport (page 5)
Squealing brake	badly aligned frame	Check hose connections and hose for leaks; replace hose if necessary (pages 14/15)
	Paint/ powder coating on fitting eyelets	align brake caliper with 0,2 mm spacers (page9) remove any paint or powder coating and care for an even contact surface without burrs. (page7)
	Wheel q/r skewer insuffici- ently tightened Insufficiently tightened wheel spokes	Increase tightening of q/r skewer and mount it on opposite side of caliper.
contaminated brake pads	carelessness	check for an evenly spaced wheel with high spoke
contaminated rotor	carelessness	tension brake pads must be changed
wheel cannot be mounted	Lever blade was pulled with removed wheel	clean rotor with MAGURA Brake Cleaner, dish water or alcohol Push back the brake pads
rattling noise and rough dece- leration	brake pads worn, holder of pads is wearing the rotor	with transport device or a flat blade screwdriver. (page12)
leaking hose or brake	accident, incorrect installation	brake pad change (page 12)
		change hose or defective brake lever or caliper (page 14)



You will find further tips on our website www.magura.com in the FAQ section!! Stay tuned.

12. Accessories



MAGURA disc brake service kit

contains everything that you need for bleeding and repairing a brake.
ATTENTION: the kit does NOT include a spare hose!



MAGURA braided hose for all MAGURA disc brakes

Spare part no. see page 20.

Watch out for the genuine hose with yellow MAGURA marker!!



Use only genuine MAGURA brake pads!

brake pads Marta Performance Type 6.1: code 0722 418
series pad for maximum brake power
brake pads Marta Endurance Type 6.2: code 0722 419
with optimized longevity

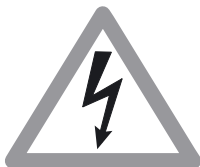

Use only genuine MAGURA accessories! Any parts manufactured by other manufacturers like lever blades, hoses or brake pads have not been tested and approved by MAGURA and consequently nothing can be said about their short and long-term function. Never use those parts! All warranty and product liability claims will be void in case of misuse!

Never change the paint, the finish or the consistence of your brake. This might cause total failure of the whole system with possible heavy bodily injury!

13. Warranty



MAGURA is giving a **5-year leakproof warranty** on brake levers (master cylinder) and brake calipers **if you register your brake online on magura.com**. Watch out for the red info sheet in the middle of this manual!

This warranty is void when damage to the brake has occurred from the following:

abuse
mixing and matching the brake with parts from other manufacturers
damage of the exterior finish caused by improper use
any attempt to disassemble the whole brake
modifications
non-factory changes or improper service

We expressly point out that a warranty claim is only accepted with a clear proof of purchase (payment receipt of the dealer!) and recommend to register your brake online on magura.com

14. Spare parts 2011/max. tightening torques

carbon lever blade 1x
0724 040
FR lever blade 1x
0724 534



Torx T7 key 0720 847

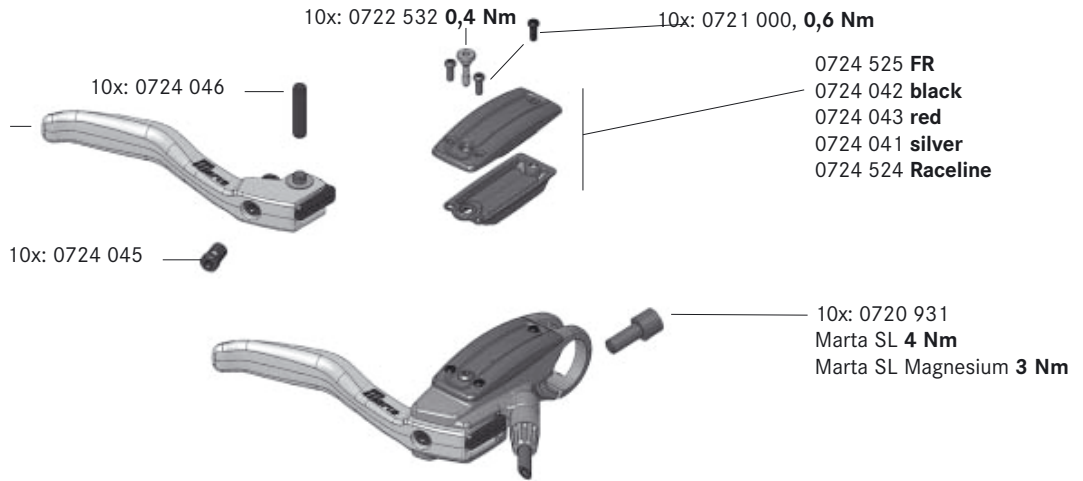

Storm SL Rotor 6 holes (IS)

203 mm 0724 404
180 mm 0724 403
160 mm 0724 402
140 mm 0724 401

Storm Rotor 6 holes (IS)

203 mm 0724 400
180 mm 0724 399
160 mm 0724 398

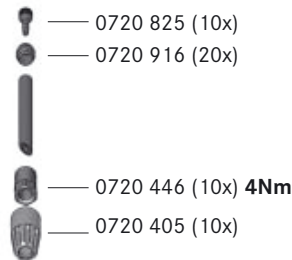

0720 848 (10x)
2,5 Nm

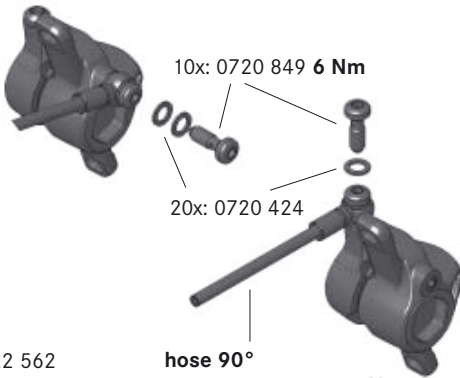

hose 0°
250 cm: 0722 636, black 6 Nm
0724 535 white

braided hose 0°
250 cm: 0721 386, 6 Nm

Titanium bolt kit 0722 562
1x M5x18
6x M5x10
2x M6x18

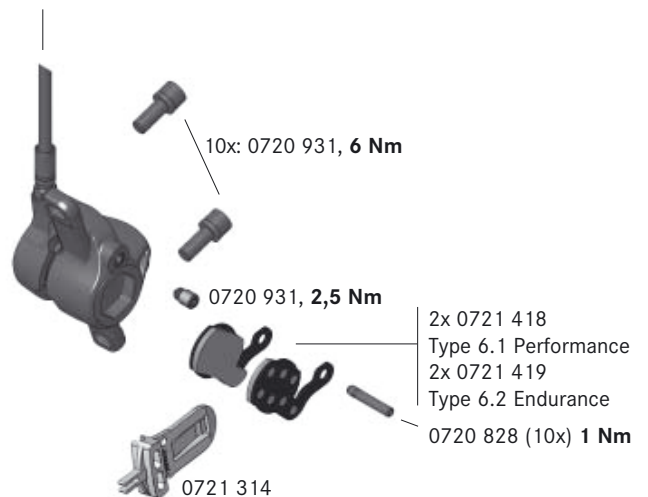

Specifications are subject to change without prior notice!

Deutsch

English

Français

Nederlands

Italiano

Español

Brake lever complete

Marta SL Magnesium:

left: 0724 038

right: 0724 037

Marta SL (black)

left: 0724 507

right: 0724 508

Marta SL (red)

left: 0724 146

right: 0724 145

Marta (black)

left: 0724 034

right: 0724 033

Marta SL Raceline:

left: 0724 509

right: 0724 510

Marta FR

left: 0724 517

right: 0724 518

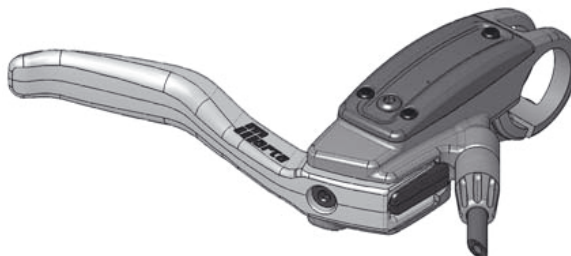

Caliper with pads

Marta SL Magnesium

0724 049

Marta SL (black)

0724 047

Marta SL (red)

0724 147

Marta (black)

0724 047

Marta SL Raceline

0724 531

Marta FR

0724 532



15. Adaptors/mounting alternatives for Marta Postmount caliper



Adaptor	Rotor diameter/Installation	Order code
Adaptor 5	203/Int. Standard 6" Front	0722 321
Adaptor 6	180/Postmount 6" Front	0722 322
Adaptor 7	203/Postmount 6" Front	0722 323
Adaptor 8	203/Rockshox Boxxer	0722 324
Adaptor 9	203/Int. Standard Rear	0722 325
Adaptor 10	180/Int. Standard Rear	0722 424
Adaptor 11	160/Int. Standard 6" Front 203/Int. Standard 8" Front (Fox 40)	0722 425
Adaptor 12	180/Int. Standard 6" Front 160/Int. Standard Rear	0722 426
Adaptor Nr. 26	203 Postmount 7" Front (Thor)	0724 131
Direct Mount	203/Postmount 8" Front (Wotan, Travis etc.) 180/Postmount 7" Front (Thor)	
(no adaptor!)	160/Postmount 6" Front	

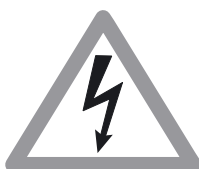

WARNING!

Always make sure, that the fixing bolts are screwed in to a depth of at least 8 mm. This corresponds to around 8 full turns!
Should this not be the case, longer bolts, with a minimum hardness of 8.8 should be used and secured using blue Loctite.



Specifications are subject to change without prior notice !
Visit our website magura.com for further information, tech tips and free online help!!

Deutsch

English

Français

Nederlands

Italiano

Español

> SIE FINDEN UNSERE WELTWEITEN HANDELSPARTNER
UND SERVICE CENTER AUF MAGURA.COM!

> CHECK OUT OUR WORLDWIDE PARTNERS AND
SERVICE CENTERS ON MAGURA.COM!

Deutschland

MAGURA Bike Parts
GmbH + Co. KG
Heinrich-Kahn-Strasse 24
89150 Laichingen
phone +49 (0)7333 9626-0
fax +49 (0)7333 9626-17
info@magura-bikeparts.de

Asia

MAGURA Asia Limited Co.
No. 160, Sec. 1, Chang-an Road
Shi-Tun District
40743 Taichung City, Taiwan
phone +886 4 2316 3388
fax +886 (04) 2315 4030
info@magura.com.tw

USA

MAGURA USA
724 West Clem
62450 Olney, Illinois
phone 6183952200
fax 6183954711 magura@
magurausa.com

© MAGURA 2010
All rights reserved
Printed in Germany
0689 723, 07.2010



MAGURA

THE PASSION PEOPLE
www.magura.com