



COIN MECHANISMS INC.

Where The Money Meets The Machine

PO Box 5128, 400 Regency Drive, Glendale Heights, IL 60139-5128 VOICE: 630/924-7070 1-800-323-6498 FAX: 630/924-7088

USER MANUAL
UNIVERSAL TEST STATION II
P/N 00660011
REV. B 1/20/04

OVERVIEW

The Universal Test Station II is used to test, adjust and troubleshoot all Coin Mechanisms products. The Test Station continuously monitors Sense, Credit and Tilt. A **DC VOLT METER** is used to check or adjust the sensor coils null or potentiometer settings. An Inhibit switch is available for those model comparitors using this “disable coin acceptance” feature.



CONTENTS

TOPIC	PAGE
Understanding the product test specification.....	3
Procedure to use the Test Station.....	4 – 5
How to read the Test Station displays.....	6 – 7
Description of switches.....	8
Detailed procedures for Air Balancing CC/MC Comparitors Using the Test Station.....	9 – 12
Detailed procedures for Air Balancing CC/MC Comparitors Using an Oscilloscope.....	13 – 14
Detailed procedures for Air Balancing the Intelligent Comparitors Using the Test Station	15 – 16
Detailed procedures for Air Balancing Intelligent Comparitors Using an Oscilloscope.....	17 – 18
Detailed procedures for Air Balancing the Defender Comparitors Using the Test Station	19 – 21
Detailed procedures for Air Balancing Defender Comparitors Using an Oscilloscope.....	22 – 24
Detailed procedures for adjusting the Defender Comparitors rail.....	25
PCB Test Procedures.....	26
Reference	
• Coin Comparitor identification.....	27 & 28
• Intelligent Comparitor identification.....	29
• Defender Comparitor identification.....	30
• Coin Comparitor pin number identification.....	31 – 35
• Coin Comparitor Test Point identification.....	36 – 45
• Test Stand.....	45
• Damper weight Chart.....	46 & 47
• Accessories.....	48 & 49

Understanding the Product Test Specification

Product Specification sample sheet

- The UNIT SPECIFICATION section of the product test specification sheet shows the Model, CMI#, Revision level, PCB and firmware part number. Next to the firmware part number is the firmware description. Here it will indicate if the product / firmware is used in an Optic Emulation application.
- The POWER SUPPLY section indicates the minimum and maximum operating voltage as well as the minimum and maximum operating current at both idle and peck conditions.
- The TEST STATION CABLES section tell you what Customer Interface harness to use and what cable to use for coil balancing.
- The CUSTOMER INTERFACE section defines the pin assignment of the customer interface header.
- The OUTPUTS section indicates what you should see displayed on the Sense, Credit and Tilt LCD displays on the test station when a good coin/token is dropped through the mechanism and accepted. If the product is used in an Optic Emulation application, this section will also show what the Delay time should display.
- The INHIBIT CONTROL section indicates the Inhibit logic. The customer interface automatically connects the Inhibit line to the correct Inhibit logic.
- The MECHANICAL section indicates various items that refer to the mechanical configuration of the product. These items are affected by coin size and weight as well as mounting considerations.
- The "COIN RANGE" section indicates the range of physical coin dimensions and weight that are accommodated by the product.
- The PERFORMANCE section indicates the voltage range of the potentiometer and the coin that was used to test the product at the factory.



COIN MECHANISMS INC.

Where The Money Meets The Machine

PO Box 5128, 400 Regency Drive, Glendale Heights, IL 60139-5128 VOICE: 1-630-924-7070 FAX: 1-630-924-7088

UNIT SPECIFICATIONS

Model: MC-16 Body Style: Standard
 CMI #: 66460041 Rev I/F Cable: None Personality: PR-09
 PCB: 0927-000304 Blank PCB: 0827-000099
 Firmware: 09290360 FW Desc:

POWER SUPPLY	Minimum		Maximum	
	Operating Voltage Range	20V AC / 23V DC	30V AC / 40V DC	
Nominal Input	24V AC/DC			
	Typical Current Draw - IDLE	50mA AC / 52mA DC	70mA AC / 106mA DC	
	Typical Current Draw - PEAK	188mA AC / 183mA DC	255mA AC / 215mA DC	

Test Station Cables
 Customer Interface: 0928-000141, 24V, 6JST, INH-NO, SSR
 Test Header: NONE, Use 0821-009080 & 9081 BNC Cable & Clip for Raw Null and Coil Balance

CUSTOMER INTERFACE Requires mating connector JST XHP-6 Housing and SXH-001T-0.6 Terminals

6-Pin JST	ID: 6J05B						
PIN OUT	PIN 1	PIN 2	PIN 3	PIN 4	PIN 5	PIN 6	PIN 7
I/O	-	Output	-	Input	Input	Ground	-
FUNCTION	-	SENSE (SR)	-	POWER 24V	POWER 24V	GROUND	-

OUTPUTS	TYPE	V Max.	I Max.	Pulse Width
SENSE	Sourcing	12V DC	10 mA	13mS +/- 1mS
CREDIT	Not Available	-	-	No Credit Pulse
TILT	Not Available	-	-	No Tilt Pulse

INHIBIT CONTROL	DISABLE Voltage		ENABLE Voltage	
	Maximum	Minimum	Maximum	Minimum
Active: Not Available	-	-	-	-

MECHANICAL For coin diameters from .700" to .879 install coin exit spacer P/N 04660021.
 Chassis: 06660058 CC/MC Std / 0 Studding: 4B Optic Sensor: None
 OIL Config: CC-MC Standard Coil Gap: .125" Token Holder: N/A
 Housing: 04660166.150 snap in Lever Weight: 2.6 Gram Exit Spacer: None

COIN RANGE	DIAMETER		THICKNESS		WEIGHT	
	Minimum	Maximum	Minimum	Maximum	Minimum	Maximum
	0.880in / 22.35mm	1.470in / 37.34mm	0.055in / 01.40mm	0.115in / 02.92mm	3.0 Grams	4.4 Grams

ENVIRONMENTAL Operating TEMP: 0 to 60 Degrees C Storage TEMP: -40 to 80 Degrees C
 EMI Note: Meets European ElectroMagnetic Conformity to display the CE Mark, Standards EN55014, EN55104, TUV License No. V9771840.01

PERFORMANCE Feed Rate: 8 Coins/Sec > 98% Good Coin Acceptance
 POT Range: 0 to 1.5 Volts Coin Profile:
 Test Coin: U.S. 25 CENT (Quarter) Test Coin #: 04091436

Step by step procedures on how to use the new Test Station.

1. Plug the AC line cord into the back of the Test Station (the line cord is made so it will only fit into the power entry module in one direction).

NOTE: Before proceeding, verify that the power switch on the back of the test station is in the down (OFF) position.

2. Plug the AC line cord into an AC outlet.
3. Consult the product specification sheet for the correct interfaces needed to test the product. See page 3 for a sample specification sheet. It is important to first select the correct interface for the product to be tested. The interface is designed to automatically supply the proper operating voltage to any Comparitor product. The interface also connects the Inhibit circuit to the correct logic level.
4. Verify that the "INTERFACE POWER" switch on the front of the test station is in the down / off position.
5. Connect one end of the customer interface into the "CUSTOMER INTERFACE" connection of the test station and the other into the customer header on the left side of the mechanism.
6. If the Comparitor model you are testing uses a test header, connect one end of the test header interface to the "TEST HEADER" connector on the test station and the other end to the mechanism test header on the pcb.

If the product you are testing does not have a test header, connect the BNC cable (CMI part number 0821-009080) with clip (CMI part number 0821-009081) to the BNC connector on the Test Station labeled "RAW NULL" and the Red minigripper connector to the coil balance Test point on the Pcb. See pages 36 – 45 for specific test point locations

7. Set Inhibit as follows – "INHIBIT / ENABLE to the down or ENABLE position.
8. Toggle the Test Station power switch (on the back of the Test Station next to the AC line cord) up (on). The displays (Sense, Credit and Tilt) will light up. The SENSE display will display "COUNT RESET 4600" on the first line and L--.-- on the second line. The Sense display will not display the D--.-- seen on the other displays. See figure below. When power is applied to the Test Station the LED above the Inhibit (INHIBIT / ENABLE) will light up (if the Inhibit switch is in the down / ENABLED position the LED will be Green. If the Inhibit switch is in the up position / INHIBITED the LED will be Red).

SENSE



COUNT RESET 4600
L - - . - - -

When the power is applied to the Test Station the CREDIT and TILT displays will display "COUNT RESET 1800" on the first line and L--.-- and D--.-- on the Second line.

See figure below



COUNT RESET 1800
L - - . - - - D - - , - - -

9. Toggle the "INTERFACE POWER" switch to the up position. The LED above the "INTERFACE POWER" switch will light and be Green.
10. Refer to the coil balance procedures and balance the Sense coils.

NOTE: When balancing the Sense coils the maximum allowable DC volt reading on the new test station is 2.00VDC.

11. Remove the test header interface from the mechanism test header.
12. Remove poker chip from Sense coils
13. Install documented test coin into the resident side of the Sense coil of the unit under test.
14. Set the pot to the 9:00 position unless specified otherwise. Drop 50 valid coins (same as the coin in residence) through the product. The count for the Sense display will equal the number of valid coins dropped and accepted by the mechanism. If the mechanism uses exit optics, the count for the Credit display will equal the Sense display for all valid coins exiting the "accept" side. If the product is being used in an Optic Emulation application, the Credit and Tilt displays will equal the Sense display. In the case of software 0950-000040, 0950-000059 or 0950-000075 the Credit display will display 2 counts for every coin. If any of the counts DO NOT match the number of coins dropped, there may be a problem. Always reset the displays when you want to retest a mechanism and after each passing mechanism.
15. Test any fraud coins (if known)
16. Test Inhibit (if applicable)
17. Test Tilt conditions (if applicable)
18. Before disconnecting the tested mechanism, toggle "INTERFACE POWER" switch down. The LED above the "INTERFACE POWER" switch will go out.

How to read the Test Station Displays

When a coin is dropped, the “**RESET XXXX**” disappears and a number is displayed next to the word **COUNT**. This number (4 digits) indicates the amount of coins that were properly identified and counted for that parameter. It can count up to a maximum count of **9999**.

The second line will display an “**L --.---**” and a “**D--.---**”. These displays show two digits to the left of the decimal point (Seconds) and three decimal places to the right of the decimal point (milliseconds). The maximum time displayed can be 99.999 seconds which is 99 seconds and 999 milliseconds. Milliseconds = mS. The Sense display does not have the “**D--.---**” on the second line.

The “**L**” is the pulse Length (e.g. Sense, Credit or Tilt) and displays the last recorded event.

The “**D**” is the Delay or the time between the previous pulse (display to its left) and its own pulse. (e.g. the Credit display will display the time (Delay) between the leading edge of the Sense pulse and the leading edge of the Credit pulse and the Tilt display will display the time (Delay) between the leading edge of the Credit pulse and the leading edge of the Tilt pulse). This “Delay” time and if it is positive or negative is important when Optic Emulation firmware is being tested.

Below shows an example of the Sense display. This display does not have a “**D**” (Delay) section on the second line. This example shows a count of 1 and a pulse Length of 17mS.

SENSE

COUNT RESET 0001 L 00.017
--

Pulse Length = 17mS

Below shows an example of one coin being dropped (**COUNT 0001**), the pulse length was 17mS long, and there was a 90mS delay between the displayed signal and the previous signal. The figure below shows the Credit display where “**D**” Delay indicates the time from the leading edge of the Sense pulse to the leading edge of the Credit pulse. The specification sheet will tell you if the Delay is necessary to monitor and if the Delay is positive or negative for any particular test.

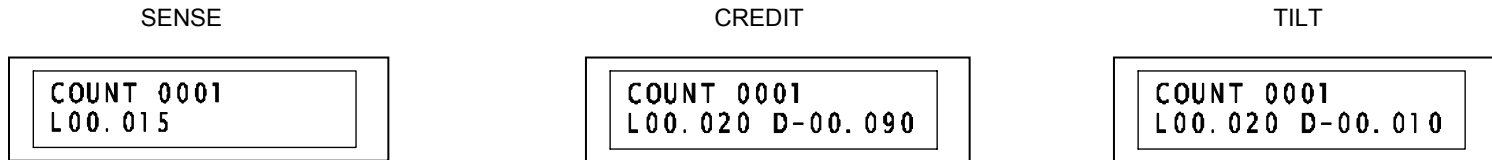
COUNT RESET 0001 L 00.017 D-00.090
--

Delay Length = 90mS

OPTIC EMULATION EXAMPLE

The following figures show an example of a single coin drop when optic emulation firmware is used.

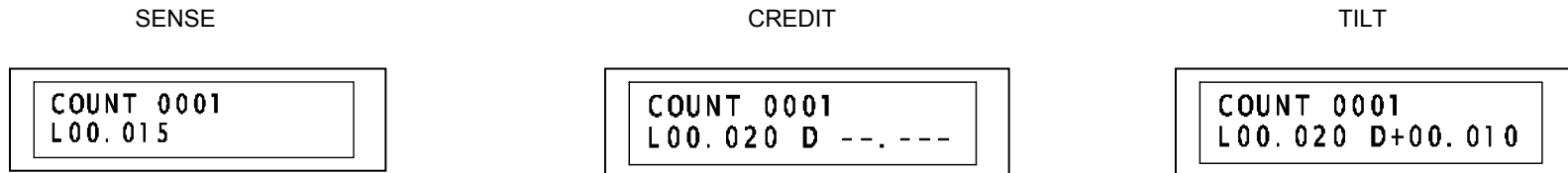
NOTE: SENSE pulse length is 15mS long, CREDIT is 20mS(A OPTIC) (the "D" or Delay is not a concern, the 00.090 is indicating that it took 90mS for the coin to travel from the Sense coils to the exit optics). That time can change depending on how fast the coin is traveling. The pulse TILT is 20mS long (B OPTIC) with a DELAY of -10mS.



OPTIC EMULATION REVERSE COIN EXAMPLE

The following shows the same as above however for reverse coin test.

NOTE: TILT pulse is 20mS long and the DELAY is +10mS. The positive sign (+) before the 00.010 is correct for a reverse coin because the "B" optic occurred before the "A" optic.



DESCRIPTION OF SWITCHES

MAIN POWER SWITCH

Located on the back of the Test Station. This switch controls power to the Test Station.

INTERFACE POWER

Switches power on and off to the CUSTOMER INTERFACE connector.

INHIBIT / ENABLE

Used to manually inhibit the mechanism (stop accepting coins) .

NULL / POT

The **NULL / POT** switch determines which DC voltage signal is displayed on the **DC VOLT METER**. When balancing a SENSOR coil, set the switch in the down or **NULL** position and adjust the coil balance set screws to get the lowest reading on the DC volt meter. Select the **POT** position to display the DC volts of the potentiometer.

RESET LCDs

This momentary push button switch clears all LCD displays of information after testing each device or when you want to repeat a test.

DESCRIPTION OF CONNECTORS

Customer interface – Connects to the customer test interface connector and to the mechanism. Determine which interface is required using the product spec sheet and connect that interface between **JP2** and the mechanism.

Test Header – This connector is used for products with an internal test header. This connector has multiple uses (different pins have different functions depending on the Test Header Interface used). This is why it is so important to use the correct interface.

BNC CONNECTOR –

The **RAW NULL** BNC connector will be used to balance coils on products that do not have a test header (e.g. CC, MC). Connect the (0821-009080 cable and 0821-009081 BNC to minigrabber clips) RED clip (of the BNC to minigrabber) to the designated CC or MC test point, push the **NULL / POT** switch to the **NULL** position and balance the coils to the lowest reading on the **DC VOLT METER** follow the balancing procedures.

NOTE: When balancing the Sense coils using the Test Station, leave the black minigrabber ground connector disconnected, with the mechanism connected to the test station through the customer interface, the test station is at the same ground potential as the mech.

When balancing the Sense coils using an oscilloscope, the ground connector of the scope does need to be connected to a ground point on the pcb in order to have the scope at the same ground potential as the mechanism.

NOTE: Older test stations use an analog balancing meter. 6 μ A DC is equal to approximately 2.00 volts on the new test station **DC VOLT METER**. If this Null signal was monitored on an oscilloscope, the P-P voltage is approximately 700mV or 350mV max. This will continue to be the maximum allowable limit for a good NULL.

DETAILED PROCEDURE FOR AIR BALANCING THE SENSOR COILS USING THE COMPARATOR TEST STATION

INTRODUCTION:

Air balancing the sensor coils is one of the most important adjustments made to the coin Comparator. Air balancing simply means to adjust the gap between the coils, to create an electrical field that is equal in both coin slots. It is important to adjust both coil sensor screws on the CC product line to an equal depth into the sensor coil body. By following this procedure, a uniform magnetic field will be maintained in the sensing area. Coin travel and sensing metal content of coins and tokens can be made more accurately. In addition, proper rail insert adjustment will complete the air balance procedure by providing a means to match the resident coin to the falling coin so they “eclipse” in the sensor coils. There is no rail adjustment on the Intelligent Comparator product line. Another performance related adjustment is the selectivity potentiometer. Proper selectivity adjustment will improve coin / token acceptance vs. slug rejection. Pages 31– 35 illustrates the input/output pin assignments for the various Coin Comparators that Coin Mechanisms Inc. manufactures.

WHY AIR BALANCE THE SENSOR COILS?

- 1) After installing a new sensor coil assembly into a Comparator.
- 2) After installing a rebuilt sensor coil assembly into a Comparator.
- 3) Typical maintenance procedure for optimum performance.

TOOL LIST:

- 1) Various diameter, plastic tokens.
- 2) 1/16” hex allen head, adjusting screwdriver (CMI P/N 05090004).
- 3) Coin sticks, or coins and scotch tape.
- 4) **Comparator Test Station**, or power supply.
- 5) Oscilloscope, optional if using **the Comparator Test Station**.

AIR BALANCING PROCEDURES FOR THE CC AND MICRO (MC) COMPARITOR PRODUCT USING THE COMPARITOR TEST STATION

Preliminary setup:

NOTE: The latest versions of the MC product have a test header, refer to pages 41 & 42 for the correct pcb that matches your configuration.

1. Using pages 31 - 35 of this manual determine which mechanism will be tested.
2. Acquire spec sheet that corresponds with the Comparitor to be tested from Coin Mechanisms Inc., your local distributor or on the web at www.coinmech.com.

Caution: Care must be taken that the correct interface is used to connect the mechanism to the test station.

3. Acquire correct interface for PCB. Refer to the spec sheet of the product you are testing for the correct interface.
4. Connect interface to the "CUSTOMER INTERFACE" connection on the test station .
5. Attach interface to PCB.
6. Toggle "INTERFACE POWER" switch UP or to the ON position. The LED above the "INTERFACE POWER" should illuminate (Green)
7. Verify LED on PCB lights.
- 8a. If the mechanisms you are testing does not have a test header, connect the 0821-009080 to the BNC connector on the test station. Connect the 0821-009081 BNC to minigrabber clip to the 0821-009080 BNC cable and the RED clip to the "TEST POINT". Illustrations on pages 36 – 39, 44 & 45 show a CC-16, CC-40, CC-46 or MC equivalent, CC-62, CC-33/37, CC-32/36 Comparitors and "TEST POINT" locations.
- 8b. If the mechanism you are testing has a test header, connect the correct interface (refer to spec sheet) to the "TEST HEADER" connection on the test station. Connect the other end of the interface to the test header on the PCB.

Air Null Balance setup:

Use the plastic token chip provided with Comparitor (similar in diameter to the actual coin or token to be used later as the sample coin) and insert into the sensor coils "Sample Holder", indicated by the label "Slide To Replace Coin". The plastic token positions the coils in their optimum location to simulate typical operating conditions. (see FIG. 2 page 27).

Air Null Balance adjustment :

1. Using the 1/16" allen head hex driver, back out the sensor coil screws counter-clockwise approximately two full turns. Check the *Coil Mounting Screw* holding the sensor coils together for approximately 4-in. lb. of torque. Torque this screw to 4-in. lb. if necessary then seat the allen screws as indicated in **Air Null Balance adjustment procedure** below. (See FIG.5 page 28).
2. Using the 1/16" allen head hex driver, turn the *Sensor Coil Adjusting Screws* (see FIG. 3 page 28), clockwise until the DC VOLT METER on the test station slightly decreases or until the screws **just** touch against the center coils metal plate stop. Make sure both screws are seated with equal depth into the sensor coil body.
3. Turn the Selectivity potentiometer to the full clockwise position.
4. Start with top screw first and alternate between top and bottom screws in short .5VDC intervals, with inward (clockwise) rotation, until achieving the lowest DC volt reading on the DC VOLT METER.

Rail Insert adjustment setup:

1. Remove the plastic chip token from the "Sample Holder". Insert "Coin Sticks" into the coils insuring that the shafts of the sticks are perpendicular to the rail, using the 1/16" allen screw driver turn the rail insert screw counter-clockwise until rail insert is against the rail body, remove any slack in the assembly by applying light pressure against the coils, towards the rail assembly (see FIG 4 & 5 page 28).
2. If "Coin Sticks" are unavailable use the coin and tape method, insert coin into the "Sample Holder", remove slack, apply tape to second identical coin and lower it into the other coil gap, position the taped coin in parallel to and "eclipse" the sample coin, observe the test station DC VOLT METER for lowest reading and tape coin in place onto the main plate.

Rail Insert adjustment:

1. The rail insert adjustment allows you to optimize the position of the resident coin to the falling coin. In order to get the best "comparison" of coins they need to "eclipse" each other when they are in the center of the sensor coil. The rail insert adjustment allows this exact match to occur. Performing this adjustment optimizes against fraud coins. The adjustment also allows compensation for worn parts to bring a highly used Comparitor back to optimum operating parameters.
2. Using the 1/16" allen hex driver, turn screw slowly clockwise (see FIG. 4 & 5 page 28), observe the DC VOLT METER, it should lower, keep adjusting clockwise until lowest reading can be achieved. Remove sticks or taped coin after adjustment.

Selectivity adjustment:

1. The CC, MC and Defender products utilize a selectivity potentiometer to accommodate a wide range of coin alloys and distributions among each alloy. The selectivity adjustment allows the user to set the Comparator to a more discriminative setting if a closely matching fraud is encountered or set to a more “open” setting to accept a wide range of poorly matching coins. Turning the potentiometer clockwise on the CC and MC product sets the product to a more discriminative setting (counterclockwise for Defender). Turning the potentiometer counterclockwise on the CC and MC products allows the mechanism to accept a wider range of a poorly matched coin alloy (clockwise on the Defender).

The factory potentiometer setting is typically set at a “9:00 o’clock” position (arrow pointing straight left) for most coins. To set for the best performance/acceptance of good coins, (coins which match the sample / resident coin) start with the pot at its most discriminative setting. Turn the pot back, counter-clockwise (clockwise for Defender) in short increments, dropping coins frequently between turns, until all coins are accepted repeatedly. Fine tune as necessary to accept all good coins or tokens and reject fraud coins.

AIR BALANCING PROCEDURES FOR THE CC AND MICRO (MC) COMPARATOR PRODUCT USING AN OSCILLOSCOPE

Preliminary setup:

1. Connect scope test probe to the "TEST POINT". Illustrations on pages 36 – 39, 44 & 45 show a CC-16, CC-40, CC-46 or MC equivalent, CC-62, CC-33/37, CC-32/36 Comparitors and "TEST POINT" locations. Ground the scope ground connection to the ground input on the pcb for common ground.
2. Set the Scope VOLT/DIV. to 500 mV. per division.
3. Set the Scope TIME/DIV. to 1 mS. per division. Depending on type of scope, some waveform positioning may be necessary to view the whole waveform.

Air Null Balance setup :

2. Use the plastic token chip provided with Comparitor (similar in diameter to the actual coin or token to be used later as the sample coin) and insert this chip into the sensor coils "Sample Holder", indicated by the label "Slide To Replace Coin". The plastic token positions the coils in their optimum location to simulate typical operating conditions. (see FIG. 2 page 27).

Air Null Balance adjustment :

1. Using the 1/16" allen head hex driver, back out the sensor coil screws counter-clockwise approximately two full turns. Check the *Coil Mounting Screw* holding the sensor coils together for approximately 4-in. lb. of torque. Torque this screw to 4-in. lb. if necessary then seat the allen screws as indicated in step 3. (See FIG.5 page 28).
2. Using the 1/16" allen head hex driver, turn the *Sensor Coil Adjusting Screws* (see FIG. 3 page 28), clockwise until the wave form on the oscilloscope slightly decreases or until the screws **just** touch against the center coils metal plate stop. Make sure both screws are seated with equal depth into the sensor coil body.
3. Turn the Selectivity potentiometer to the full clockwise position.
4. Start with top screw first and alternate between top and bottom screws in short intervals, with inward (clockwise) rotation, until achieving the smallest amplitude of the waveform possible. Typically 80 to 200 mV is considered to be a proper null.

Rail Insert adjustment setup:

1. Remove the plastic chip token from the "Sample Holder". Insert "Coin Sticks" into the coils insuring that the shafts of the sticks are perpendicular to the rail, using the 1/16" allen screw driver turn the rail insert screw counter-clockwise until rail insert is against the rail body, remove any slack in the assembly by applying light pressure against the coils, towards the rail assembly (see FIG 4 & 5 page 28).
2. If "Coin Sticks" are unavailable use the coin and tape method, insert a coin into the "Sample Holder", remove slack, apply tape to second identical coin and lower it into the other coil gap, position the taped coin in parallel to and "eclipse" the sample coin, observe the waveform for lowest amplitude and tape coin in place onto the mainplate.

Rail Insert adjustment:

1. The rail insert adjustment allows you to optimize the position of the resident coin to the falling coin. In order to get the best "comparison" of coins they need to "eclipse" each other when they are in the center of the sensor coil. The rail insert adjustment allows this exact match to occur. Performing this adjustment optimizes against fraud coins. The adjustment also allows compensation for worn parts to bring a highly used Comparitor back to optimum operating parameters.
2. Using the 1/16" allen hex driver, turn screw slowly clockwise (see FIG. 4 & 5 page 28), observe the oscilloscope, it should lower in amplitude, keep adjusting clockwise until lowest amplitude reading can be achieved. Remove sticks or taped coin after adjustment.

Selectivity adjustment:

1. The CC, MC and Defender products utilize a selectivity potentiometer to accommodate a wide range of coin alloys and distributions among each alloy. The selectivity adjustment allows the user to set the Comparitor to a more discriminative setting if a closely matching fraud is encountered or set to a more "open" setting to accept a wide range of poorly matching coins. Turning the potentiometer clockwise on the CC and MC product sets the product to a more discriminative setting (counterclockwise for Defender). Turning the potentiometer counterclockwise on the CC and MC products allows the mechanism to accept a wider range of a poorly matched coin alloy (clockwise on the Defender).

The factory potentiometer setting is typically set at a "9:00 o'clock" position (arrow pointing straight left) for most coins. To set for the best performance/acceptance of good coins, (coins which match the sample / resident coin) start with the pot at its most discriminative setting. Turn the pot back, counter-clockwise (clockwise for Defender) in short increments, dropping coins frequently between turns, until all coins are accepted repeatedly. Fine tune as necessary to accept all good coins or tokens and reject fraud coins.

AIR BALANCE PROCEDURES FOR THE (IC) INTELLIGENT COMPARITOR USING THE COMPARITOR TEST STATION

Preliminary setup:

1. Using pages 31 - 35 of this manual determine which mechanism will be tested.
2. Acquire spec sheet that corresponds with the Comparitor to be tested from Coin Mechanisms Inc. or your local distributor or on the web at www.coinmech.com.

Caution: Care must be taken that the correct interface is used to connect the mechanism to the test station.

3. Acquire correct interface for PCB. Refer to the spec sheet of the product you are testing for the correct interface.
4. Connect interface to the "CUSTOMER INTERFACE" connection on the test station.
5. Attach interface to PCB.
6. Toggle "INTERFACE POWER" switch UP or to the ON position. The LED above the "INTERFACE POWER" should illuminate (Green)
7. Verify LED on PCB lights.
8. Connect the correct interface (refer to spec sheet) to the "TEST HEADER" connection on the test station. Connect the other end of the interface to the test header on the PCB.

NOTE: THE IC PRODUCT AIR NULL IS PERFORMED WITHOUT USING A PLASTIC CHIP IN THE RESIDENT COIN SIDE OF THE COILS. THE TOKEN HOLDER IS IN PLACE WITHOUT A RESIDENT COIN.

Air Null Balance adjustment :

1. Using the 1/16" allen head hex driver, back out the *Coil Adjustment Screws* (see FIG. 6 & FIG. 7 page 29), counter- clockwise approximately two full turns. Check the *Coil Mounting Screws* (see FIG. 6 page 29) holding the sensor coils together at approximately 3-1/2 in. lbs. of torque. Verify the torque on the two screws that hold the sensing coil stack together.
2. Using the 1/16" allen head hex driver, turn the *Coil Adjustment Screws* on the front coil clockwise until the needle on the DC VOLT METER **just** starts to change or until the screw **just** touches against the center coil metal pin stop.
3. Install token holder (without sample token) in resident side of coils. Using token holder web as a thickness gauge, slide holder in and out of coil. If token holder binds in coil, adjust screw clockwise just until there is token holder clearance.

NOTE: DO NOT OVER ADJUST THIS SCREW AND CREATE AN EXCESSIVE GAP.

4. Insert the 1/16" allen wrench through the clearance hole in the spring retainer assy (see FIG. 7 page 29) and into the allen screw location on the number 3 (back) coil assembly. Turn the screw with the 1/16" allen wrench clockwise until you get the lowest reading on the DC VOLT METER of the Comparitor Test Station (no higher than 2.00VDC).

NOTE: Once the 1/16" allen screw on the back coil bottoms (the DC volt reading begins to get smaller), it should not take more than a quarter turn before the lowest DC volt reading has been reached. If more than a quarter turn is required to balance, contact Coin Mechanism Inc or your local distributor.

5. Adjust the *Spring Retainer Adjustment Screw* clockwise until the screw **just** touches the main plate. This is to relieve strain on the #3 coil (see FIG. 7 page 29).
6. Verify the DC VOLT METER reading returns to the settings achieved in the previous steps when the coils are squeezed together and released. Adjust coil adjustment screw on number 3 (back) coil assembly if necessary.

AIR BALANCE PROCEDURES FOR THE (IC) INTELLIGENT COMPARITOR and PRODUCT LINE USING AN OSCILLOSCOPE

Preliminary setup:

1. Connect scope test probe to J4 "TEST POINT" pin on the PCB (see pg. 40 - 43). Illustrations show IC-16, IC-40, IC-62, IC-33/37, IC-32/36 Comparitors and test point location (Raw Null). Ground the scope ground connection to J4 PIN 6.
2. Set the Scope VOLT/DIV. to 500 mV. per division.
Set the Scope TIME/DIV to 1 mS. per division. Depending on type of scope, some waveform positioning may be necessary to view the whole waveform.

NOTE: THE IC PRODUCT AIR NULL IS PERFORMMED WITHOUT USING A PLASTIC CHIP IN THE RESIDENT COIN SIDE OF THE COILS. THE TOKEN HOLDER IS IN PLACE WITHOUT A RESIDENT COIN.

Air Null Balance adjustment :

1. Using the 1/16" allen head hex driver, back out the *Coil Adjustment Screws* (see FIG. 6 & FIG. 7 page 29), counter- clockwise approximately two full turns. Check the *Coil Mounting Screws* (see FIG. 6 page 29) holding the sensor coils together at approximately 3-1/2 in. lbs. of torque. Verify the torque on the two screws that hold the sensing coil stack together.
2. Start with connecting power to J1 connector and switch on power. If the led on the PCB doesn't light, turn power off and call Coin Mechanisms Inc or your local distributor.
3. Using the 1/16" allen head hex driver, turn the *Coil Adjustment Screws* on the front coil clockwise until the on the waveform **just** starts to move or until the screw **just** touches against the center coil metal pin stop.
4. Install token holder (without sample token) in resident side of coils. Using token holder web as a thickness gauge, slide holder in and out of coil. If token holder binds in coil, adjust screw clockwise just until there is token holder clearance.

NOTE: DO NOT OVER ADJUST THIS SCREW AND CREATE AN EXCESSIVE GAP.

5. Insert the 1/16" allen wrench through the clearance hole in the spring retainer assy (see FIG. 7 page 29), and into the allen screw location on the number 3 (back) coil assembly. Turn the screw with the allen wrench clockwise until you get the lowest amplitude waveform on the oscilloscope (no greater than 500mV p-p).

Note: Once the allen screw on the back coil bottoms (the waveform begins to get smaller), it should not take more than a quarter turn before the smallest amplitude has been reached. If more than a quarter turn is required to balance, contact Coin Mechanism Inc or your local distributor.

6. Adjust the *Spring Retainer Adjustment Screw* clockwise until the screw **just** touches the main plate. This is to relieve strain on the #3 coil (see FIG. 7 page 29).
7. Verify the oscilloscope waveform returns to the same amplitude achieved in the previous steps when the coils are squeezed together and released. Adjust coil adjustment screw on number 3 (back) coil assembly if necessary.

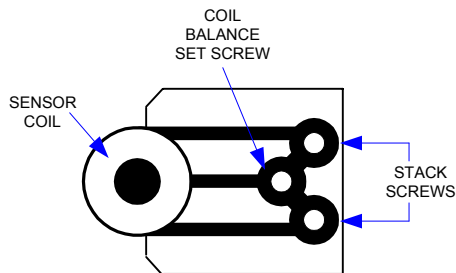
AIR BALANCE PROCEDURES FOR THE DEFENDER COMPARITOR USING THE COMPARITOR TEST STATION

Preliminary setup:

1. Using pages 31 – 35 of this manual determine which mechanism will be tested.
2. Acquire spec sheet that corresponds with the Comparitor to be tested from Coin Mechanisms Inc. or your local distributor or on the web at www.coinmech.com.

Caution: Care must be taken that the correct interface is used to connect the mechanism to the test station.

3. Refer to specific Defender specification sheet for the correct interface. The interface determines the correct inhibit logic and if the Sense signal is open collector or sourcing.
4. Place the Mechanism in a test stand (CMI # 05000009).
5. Connect the interface cable to the test station and mechanism. (For connector pin outs refer to specific spec sheets).



There is a front (resident coin) coil balance set screw, and a back (drop slot) coil balance set screw. Use a 1/16 Inch Allen Wrench Adjustment tool (CMI # 05090004).

6. Remove the Resident Coin, if present.

Air Null Balance adjustment :

1. Using the 1/16" allen head hex driver, back out the *Coil Adjustment Screws* (see FIG. 8 & 9 page 30), counter- clockwise approximately two full turns. Check the *Coil Mounting Screws* (3/32 hex head)(see FIG. 9 page 30) holding the sensor coils together at approximately 3-1/2 in. lbs. of torque. Verify the torque on the two screws that hold the sensing coil stack together.

WITHOUT COIL GAGE BAR

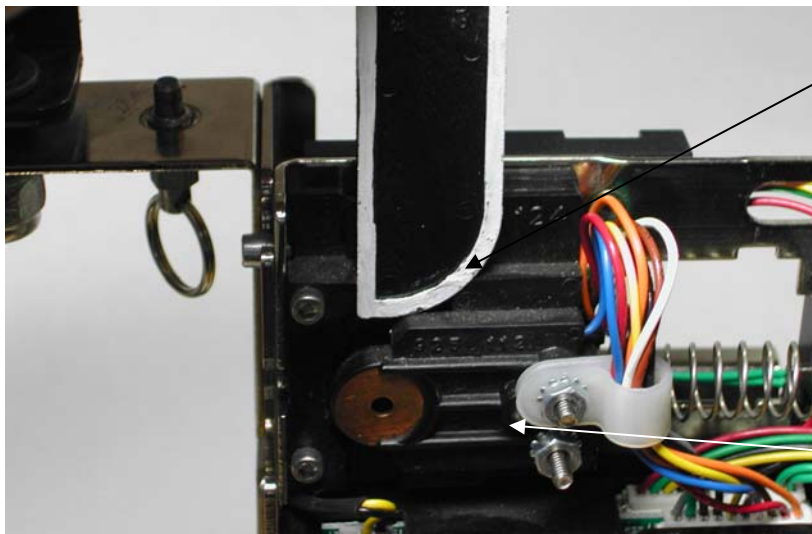
2. Using the 1/16" Allen Wrench Adjustment tool, slowly tighten the front (resident coin) coil balance set screw just to the point it bottoms out and gets a little hard to turn. Do not over tighten this setscrew. If the coils are being balanced without using a gage bar proceed to step 9.

WITH COIL GAGE BAR

3.
 - a. Insert coil gage bar, with the curve on the bottom right, (refer to table #2) between the first and second coil (resident coin gap). See picture on the next page for correct gage bar orientation.
 - b. Using the 1/16" allen head hex driver, turn the *Coil Adjustment Screw* on the front coil clockwise until the gage bar just falls through the coils.

NOTE: DO NOT OVER ADJUST THIS SCREW AND CREATE AN EXCESSIVE GAP.

- c. Remove coil balance gage bar.

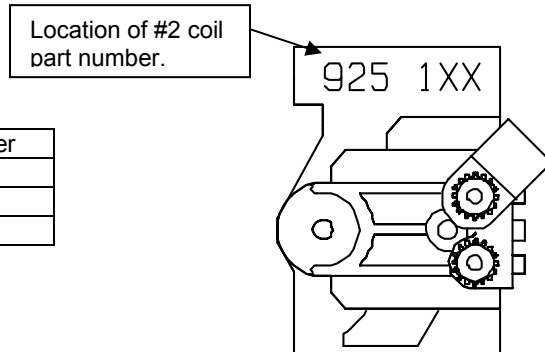


Insert gage bar with the curve towards the coils or on the right side

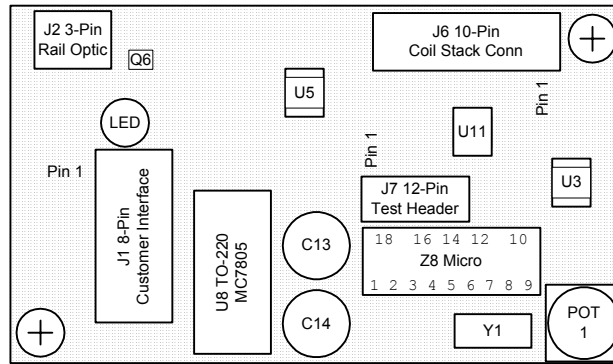
Insert 1/16" allen head screw driver into Sensor coil adjustment screw

NOTE: The gage bar used for coil balancing is determined by the #2 coil part number. See Table #2 on page21 for the correct gage bar for the different #2 coils. See Fig 8 page 30 for the location of the #2 coil part number and format.

#2 Coil Part Number	Gage Bar part number
925 111	04700026
925 123	04700027
925 124	04700033



4. Insert a small plastic poker chip (CMI # 04090014) in the resident coin location.
5. Use a 0928-000132 (12 pin Molex connector to 12 pin Molex connector) interface for the new Test Station.



Main PC Board (0927-000570)

6. Connect the 0928-000132 interface from the Mechanism test header to JP3 “MECH TEST HEADER” of the test station.
7. Apply power to the Mechanism.
8. Monitor the DC meter on the Test Station.
9. Using the 1/16” Allen Wrench Adjustment tool, slowly tighten (clockwise), or adjust, the rear (drop slot) coil balance setscrew to achieve the smallest possible Raw Null signal level.

A good null should achieve an air null balance of 0 to 6 μ A on the older Test Station.
Or a DC meter reading of less than 2.00 on the New Test Station.

NOTE: Once the allen screw on the back coil bottoms (the waveform begins to get smaller), it should not take more than a quarter turn before the lowest DC volt meter reading has been reached. If more than a quarter turn is required to balance, contact Coin Mechanism Inc or your local distributor.

NOTE: The Tilt display will continuously increment while balancing the coils.

If a good air coil balance cannot be achieved, then there could be a problem with the coil set or the main PC board. In most cases if a good coil air balance cannot be achieved then the coil set needs to be replaced.

10. Insert coil balance gage bar or your thickest coin for this model between the rear (drop slot) coil and middle coil and verify that the gage bar or coin fits. If it does not fit down the drop slot you will be required to readjust the rear coil balance setscrew until the gage bar or coin falls through.
11. If you had to readjust the rear (drop slot) coil balance setscrew again in order for the gage or coin to fit, you will be required to adjust the front (resident slot) coil balance adjustment screw again to produce the lowest possible null.
12. Verify the DC VOLT METER reading returns to the settings achieved in the previous steps when the coils are squeezed together and released. Adjust coil adjustment screw on number 3 (back) coil assembly if necessary.

AIR BALANCE PROCEDURES FOR THE DEFENDER COMPARITOR USING AN OSCILLOSCOPE

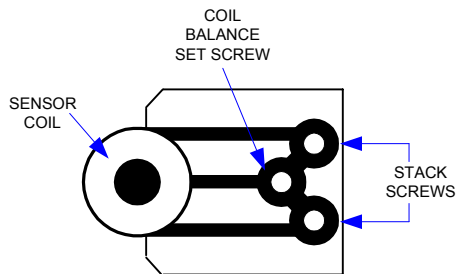
Preliminary setup:

Preliminary setup:

1. Using pages 31 – 35 of this manual determine which mechanism will be tested.
2. Acquire spec sheet that corresponds with the Comparitor to be tested from Coin Mechanisms Inc. or your local distributor or on the web at www.coinmech.com.

Caution: Care must be taken that the correct interface is used to connect the mechanism to the test station.

3. Refer to specific Defender specification sheet for the correct interface. The interface determines the correct inhibit logic and if the Sense signal is open collector or sourcing.
4. Place the Mechanism in a test stand (CMI # 05000009).
5. Connect the interface cable to the test station and mechanism. (For connector pin outs refer to specific spec sheets).



There is a front (resident coin) coil balance set screw, and a back (drop slot) coil balance set screw. Use a 1/16 Inch Allen Wrench Adjustment tool (CMI # 05090004).

6. Remove the Resident Coin, if present.

Air Null Balance adjustment :

1. Using the 1/16" allen head hex driver, back out the *Coil Adjustment Screws* (see FIG. 8 & 9 page 30), counter- clockwise approximately two full turns. Check the *Coil Mounting Screws* (3/32 hex head)(see FIG. 9 page 30) holding the sensor coils together at approximately 3-1/2 in. lbs. of torque. Verify the torque on the two screws that hold the sensing coil stack together.

WITHOUT COIL GAGE BAR

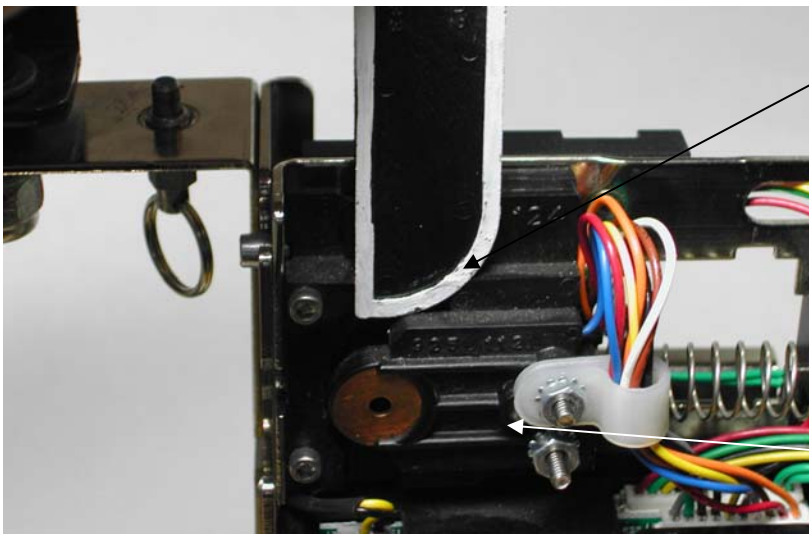
2. Using the 1/16" Allen Wrench Adjustment tool, slowly tighten the front (resident coin) coil balance set screw just to the point it bottoms out and gets a little hard to turn. Do not over tighten this setscrew. If the coils are being balanced without using a gage bar proceed to step 9.

WITH COIL GAGE BAR

3.
 - a. Insert coil gage bar, with the curve on the bottom right, (refer to table #2) between the first and second coil (resident coin gap). See picture on the next page for correct gage bar orientation.
 - b. Using the 1/16" allen head hex driver, turn the *Coil Adjustment Screw* on the front coil clockwise until the gage bar just falls through the coils.

NOTE: DO NOT OVER ADJUST THIS SCREW AND CREATE AN EXCESSIVE GAP.

- c. Remove coil balance gage bar.

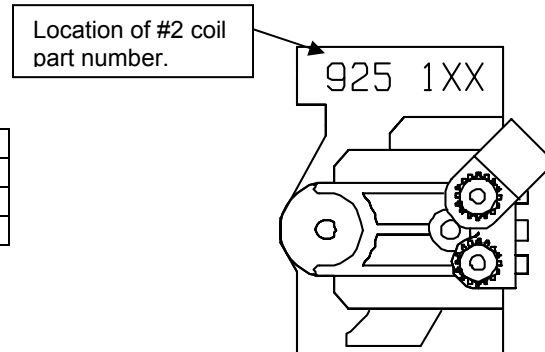


Insert gage bar with the curve towards the coils or on the right side

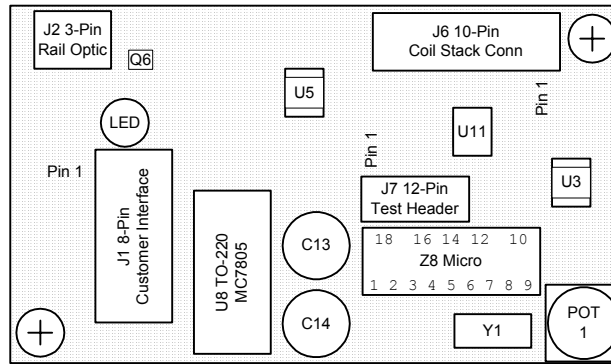
Insert 1/16" allen head screw driver into Sensor coil adjustment screw

NOTE: The gage bar used for coil balancing is determined by the #2 coil part number. See Table #2 on page21 for the correct gage bar for the different #2 coils. See Fig 8 page 30 for the location of the #2 coil part number and format.

#2 Coil Part Number	Gage Bar part number
925 111	04700026
925 123	04700027
925 124	04700033



4. Insert a small plastic poker chip (CMI # 04090014) in the resident coin location.
5. Use a 12-Pin Test Header Cable (CMI #0928-000151). Connect an Oscilloscope to Pin 6 (Raw Null) of the test header or the GRN/YEL wire of the test header interface. Connect the Oscilloscope probe ground to Pin 11 (Ground) of the test header or Black wire of the test header interface.



Main PC Board (0927-000570)

6. Set the Oscilloscope to:
Horizontal Time base to 100uS per Division.
Vertical Display to 100 mV per Division.
7. Apply power to the Mechanism.
8. Look at the Oscilloscope display. It should be displaying the Raw Null Signal, a complex waveform that can oscillate between 7 and 9 KHz and can have an amplitude of about 9 volts Peak-to-Peak maximum, and go down to about 50 millivolts minimum. You may have to adjust your oscilloscope to properly view the waveform.
9. Using the 1/16" Allen Wrench Adjustment tool, slowly tighten (clockwise), or adjust, the rear (drop slot) coil balance setscrew to achieve the smallest possible Raw Null signal level.

A good mechanism should achieve an air coil balance Raw Null signal level of less than 700 mV Peak-to-Peak, or less than 400 mV Positive Peak to Ground.

If a good air coil balance cannot be achieved, then there could be a problem with the coil set or the main PC board. In most cases if a good coil air balance cannot be achieved then the coil set needs to be replaced.

10. Insert coil balance gage bar or your thickest coin for this model between the rear (drop slot) coil and middle coil and verify that the gage bar or coin fits. If it does not fit down the drop slot you will be required to readjust the rear coil balance setscrew until the gage bar or coin falls through the Sense coils.
11. If you had to readjust the rear (drop slot) coil balance setscrew again in order for the gage or coin to fit, you will be required to adjust the front (resident slot) coil balance adjustment screw again to produce the lowest possible null.
12. Verify the oscilloscope waveform returns to the same amplitude achieved in the previous steps when the coils are squeezed together and released. Adjust coil adjustment screw on number 3 (back) coil assembly if necessary.

DEFENDER RAIL ADJUSTMENT PROCEDURE

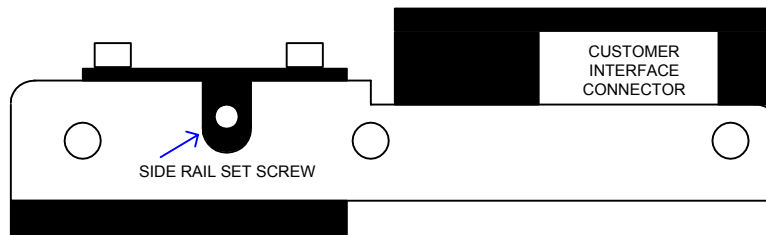
DROP SLOT DIAMETER CLEARANCE

- 1) Insert proper resident coin for the model to be adjusted.
- 2) Turn the side rail set screw out (Counterclockwise) one full turn.
- 3) Drop a good coin into the drop slot, it should get stuck. If the coin does not get stuck, push the coil set (with the resident coin installed) toward the rail (left) (this should force the rail insert in). Drop another good coin into the drop slot, the coin should get stuck. If the coin still does not get stuck, contact engineering.

NOTE: The unit may Tilt during the Drop Slot Diameter clearance adjustment procedure.

- 4) Turn the side rail set screw (using a .050" hex driver or CMI P/N 05090023) in (Clockwise) until the coin falls through the mechanism.
Drop more good coins and slightly adjust the side rail set screw until all the test coins fall freely through the mechanism.
- 5) Turn the side rail set screw an additional ¼ turn in (Clockwise) for some additional diameter clearance.

NOTE: The diameter adjustment side rail set screw must never be turned more than ¾ turn clockwise from this calibrated setting to prevent damage to this assembly.



Side View of Unit

- 6) Drop good coins through the unit.
The unit should Accept 100% of the good coins.
Each coin should generate a Sense and Credit Pulse (if applicable) as the coin falls through the mechanism

The POT setting may need to be adjusted to achieve 100% acceptance if the test coins have a wide conductivity spread.

PCB TEST PROCEDURES

1. Acquire spec sheet that corresponds with the PCB to be tested.
2. Acquire spec sheet that corresponds with the Comparator to be tested from Coin Mechanisms Inc. or your local distributor or on the web at www.coinmech.com.

Caution: Care must be taken that the correct interface is used to connect the mechanism to the test station.

3. Attach PCB to appropriate test chassis (Green accept coil wires for 12VDC, Gray accept coils for 24VDC/24VAC).

Note: Test chassis should be a known good chassis.

4. Attach interface to PCB.
5. Toggle "INTERFACE POWER" switch to the ON position.
6. Verify LED on PCB lights.
7. Insert small Poker chip in resident coin location of coils.
8. If the mechanisms you are testing does not have a test header; connect the 0821-009080 to the BNC connector on the test station. Connect the 0821-009081 BNC to minigrabber clip to the 0821-009080 BNC cable and the RED minigrabber clip to the "TEST POINT". See pg. 36 – 45 for "Test Point" location.
 - a. If the mechanism you are testing has a test header, connect the correct interface (refer to spec sheet) to the "TEST HEADER" connection on the test station. Connect the other end of the interface to the test header on the PCB.
 - b. Verify DC VOLT METER reading on test station is below 2.00VDC.

NOTE: If meter reading is above 2.00VDC, discontinue test – remove interface from PCB, remove PCB from chassis and trouble shoot PCB.

9. Remove Poker chip from resident coin coil location.
10. Insert a coin in resident coin coil location.
11. Verify INHIBIT state for PCB being tested.

NOTE: On the spec sheet, in the section titled INHIBIT CONTROL, explains at what level the PCB will INHIBIT or ENABLE. Using the new test station, the interface automatically connects the Inhibit line to the correct Inhibit logic level and the mechanism will always Inhibit when the Inhibit switch is placed in the up or INHIBIT position.

12. Verify INHIBIT Switch is in the correct position to ENABLE (down) (or to allow) the unit to accept coins.
13. Drop known good coins (same as resident coin) through the mechanism.
14. Refer to Page 6 and 7 of this document for "Display Functions" to monitor specific output pulse lengths.

NOTE: Pulse lengths may vary approximately 4mS from the documented lengths stated for your comparator.

COIN COMPARITOR IDENTIFICATION REFERENCE

FIG. 1 AND FIG. 2

FIG #1

POWER AND I/O CONNECTION

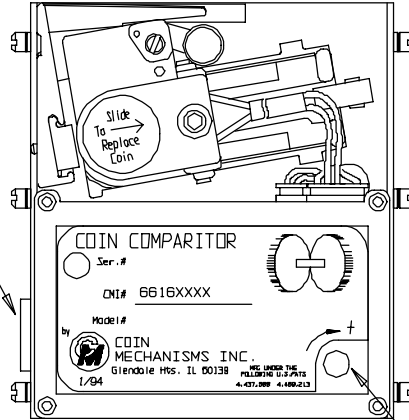


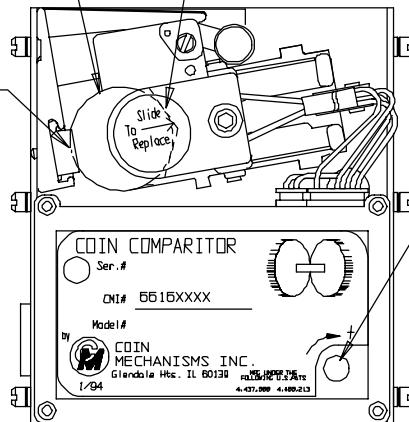
FIG #2

INSERT SAMPLE/PLASTIC TOKEN CHIP COIN HERE

SAMPLE HOLDER LOCATE COIN IN "V" GROOVE

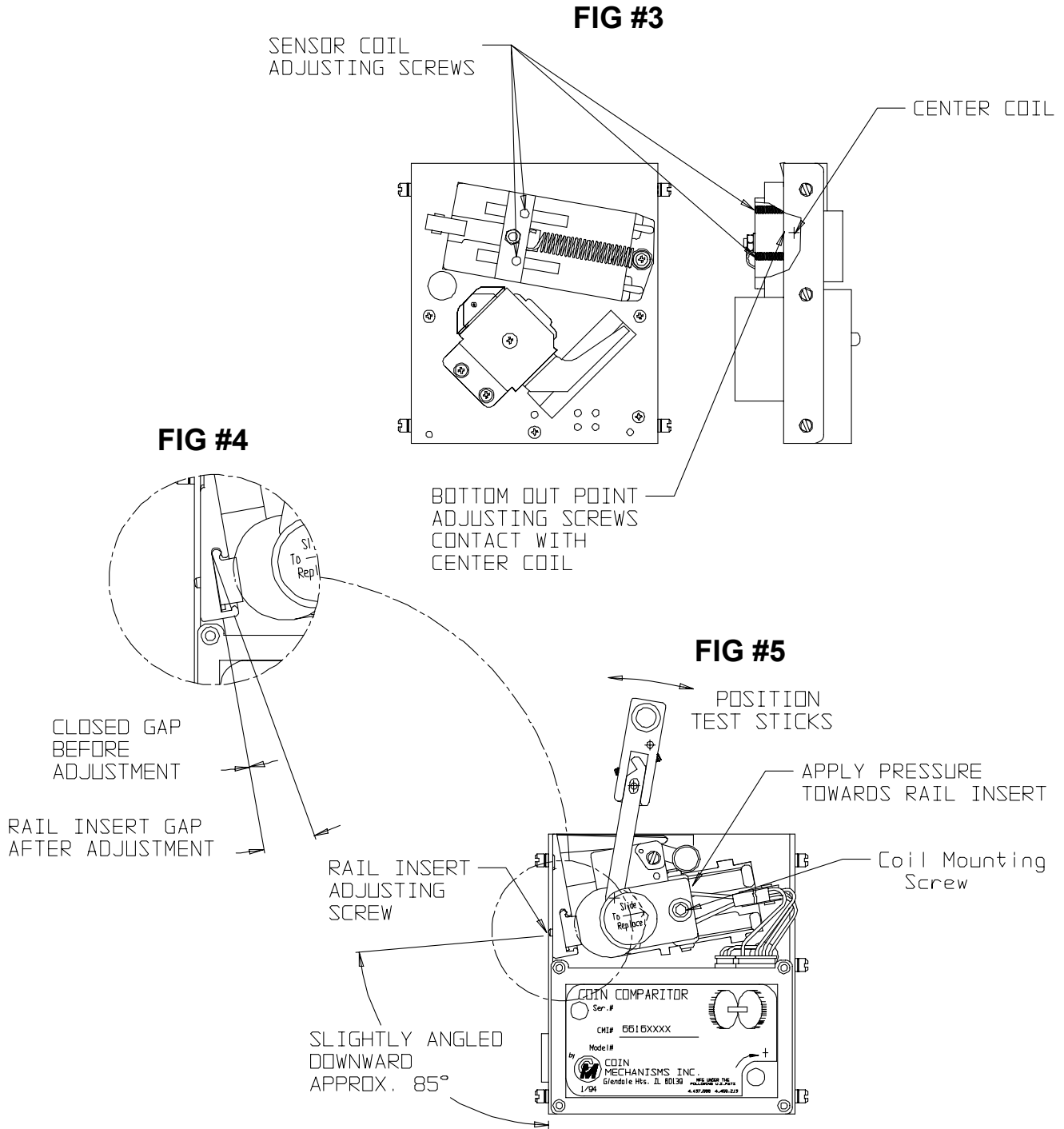
SELECTIVITY ADJUSTMENT POTENTIOMETERS

POSITION COIN IN RAIL OF RAIL INSERT



COIN COMPARITOR IDENTIFICATION REFERENCE

FIG. 3, FIG. 4 AND FIG. 5



INTELLIGENT COMPARITOR IDENTIFICATION REFERENCE

FIG. 6 AND FIG. 7

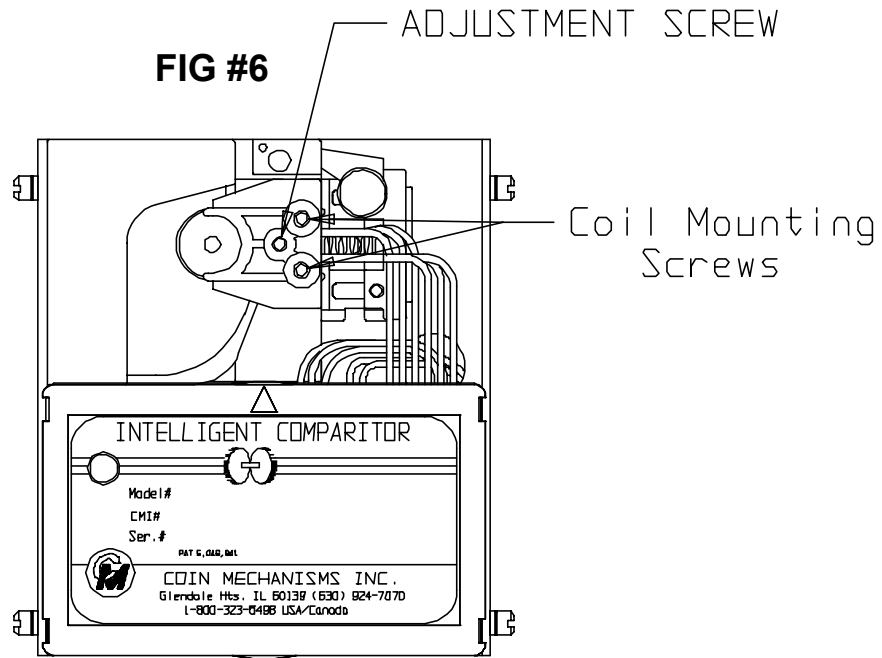
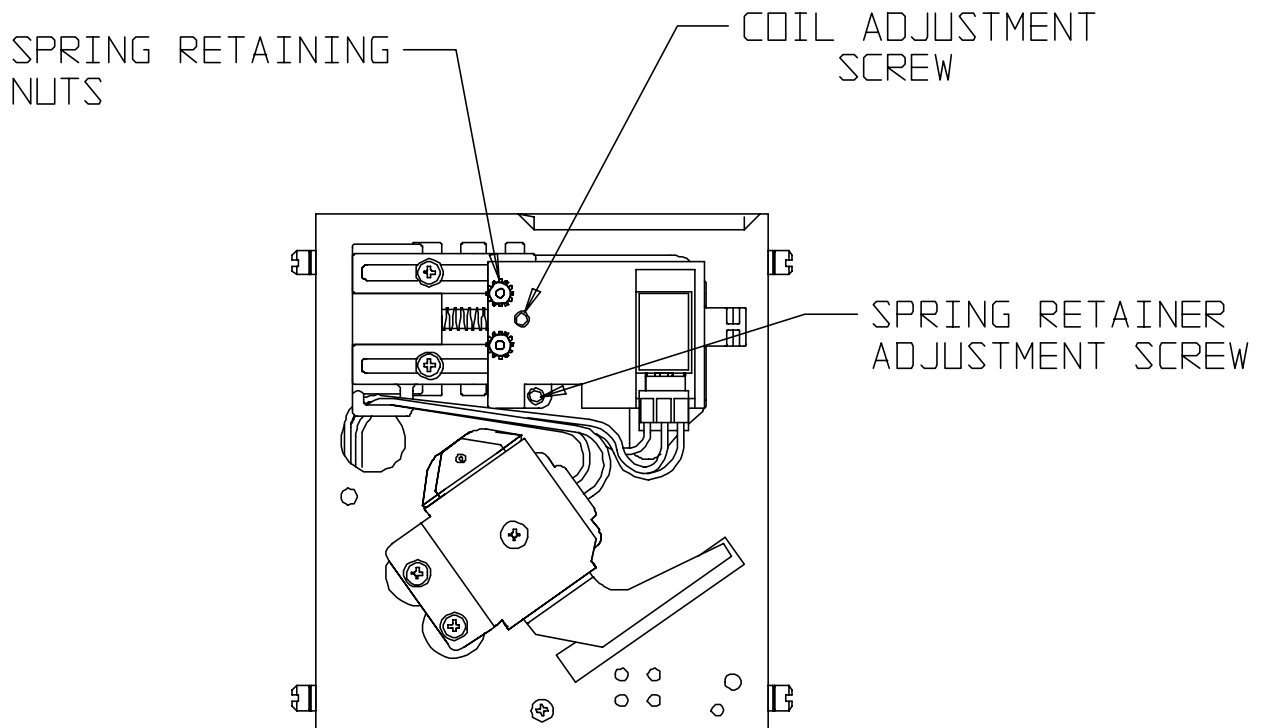
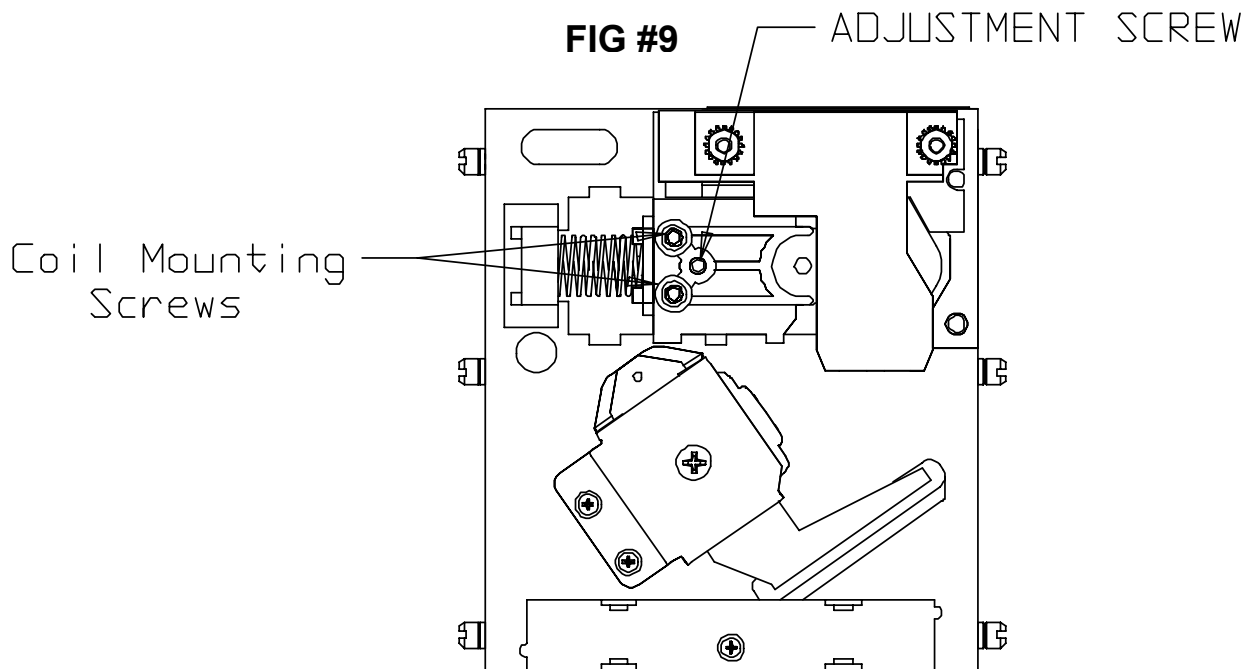
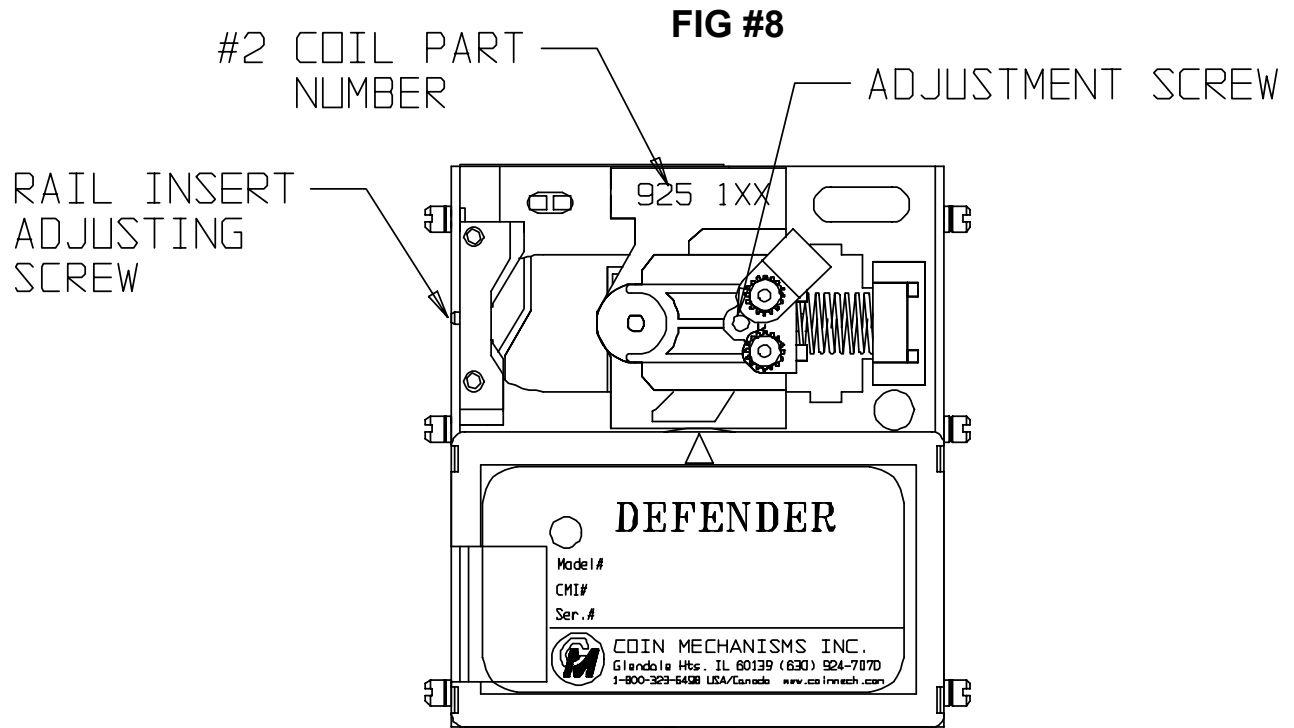


FIG #7



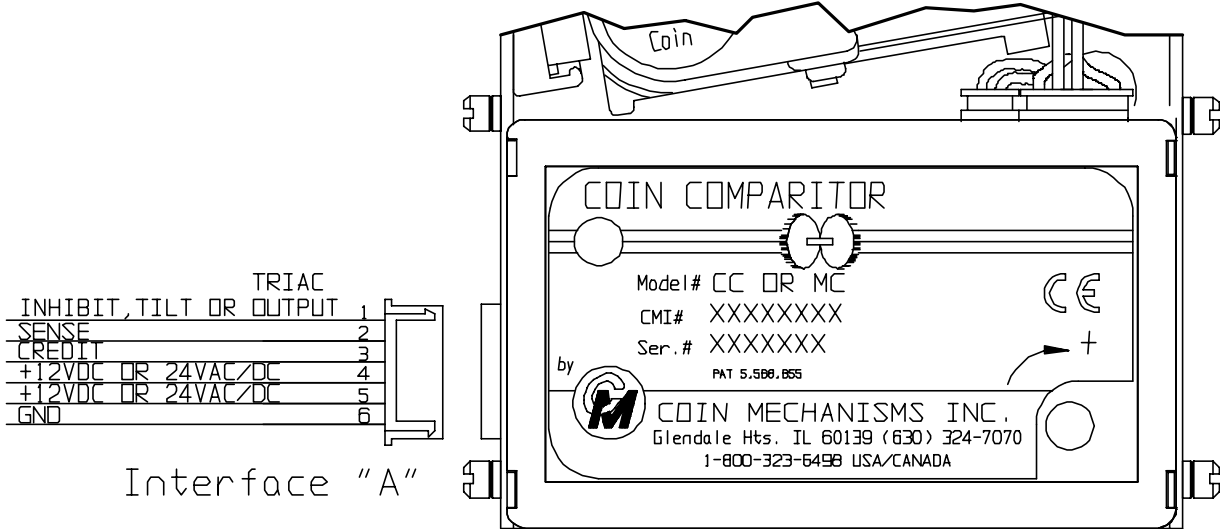
DEFENDER IDENTIFICATION REFERENCE

FIG. 8 AND FIG. 9

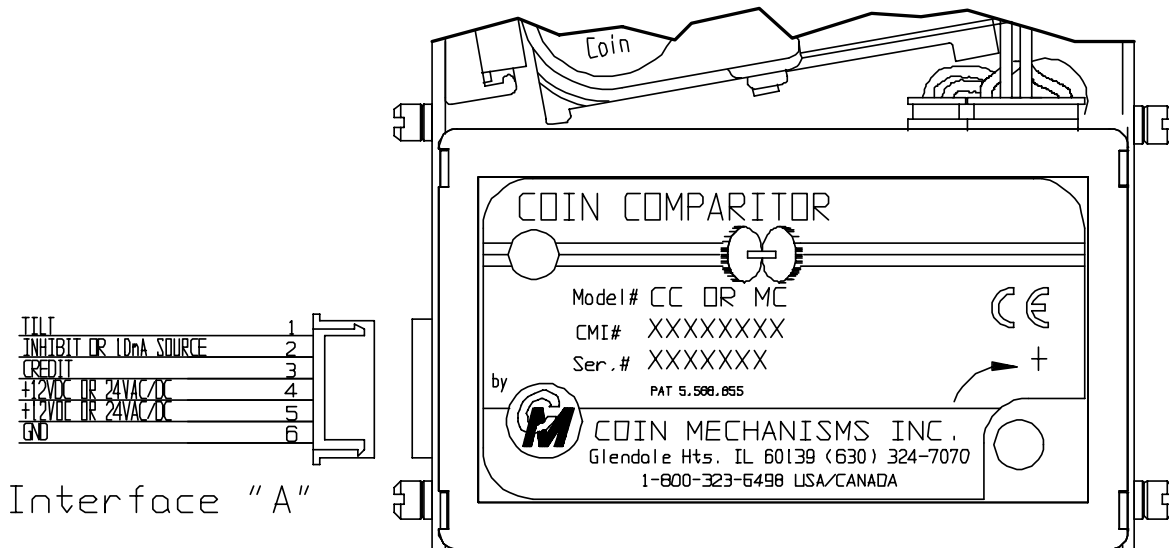


COIN COMPARITOR PIN NUMBER IDENTIFICATION

**FIG #10
CC-16 , MC-16**



**FIG #11
CC-40 , MC-40**



COIN COMPARITOR PIN NUMBER IDENTIFICATION

FIG #12
CC-33 , CC-37

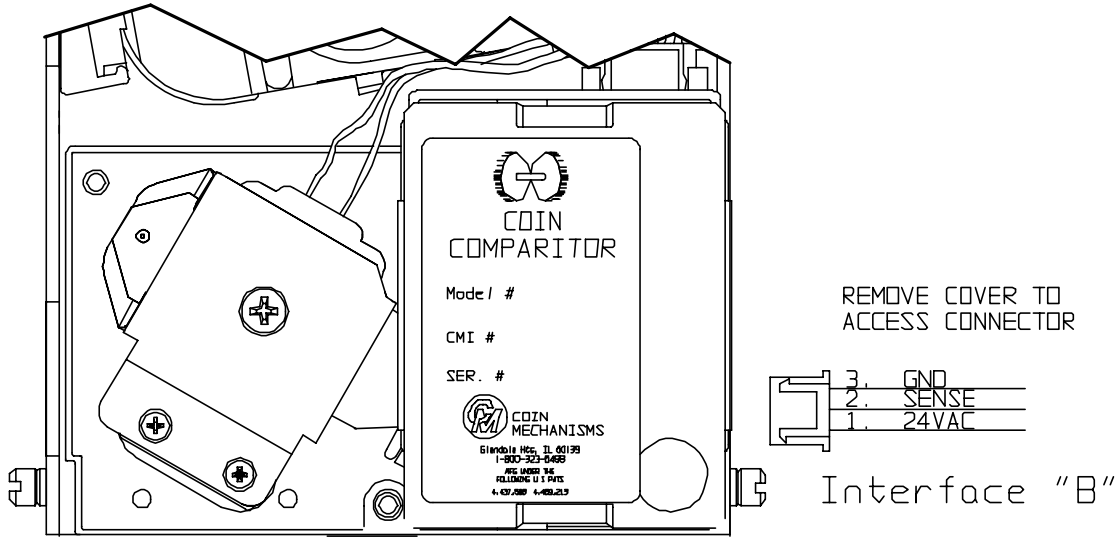
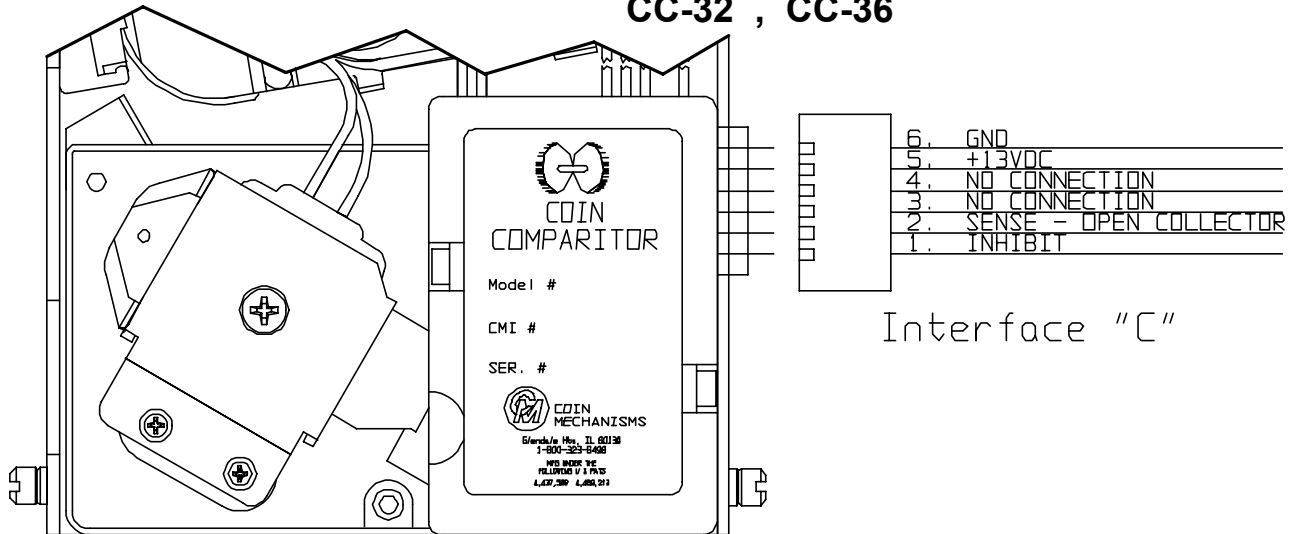


FIG #13
CC-32 , CC-36



COIN COMPARITOR PIN NUMBER IDENTIFICATION

FIG #14
MC-62 , CC-62 , IC-62

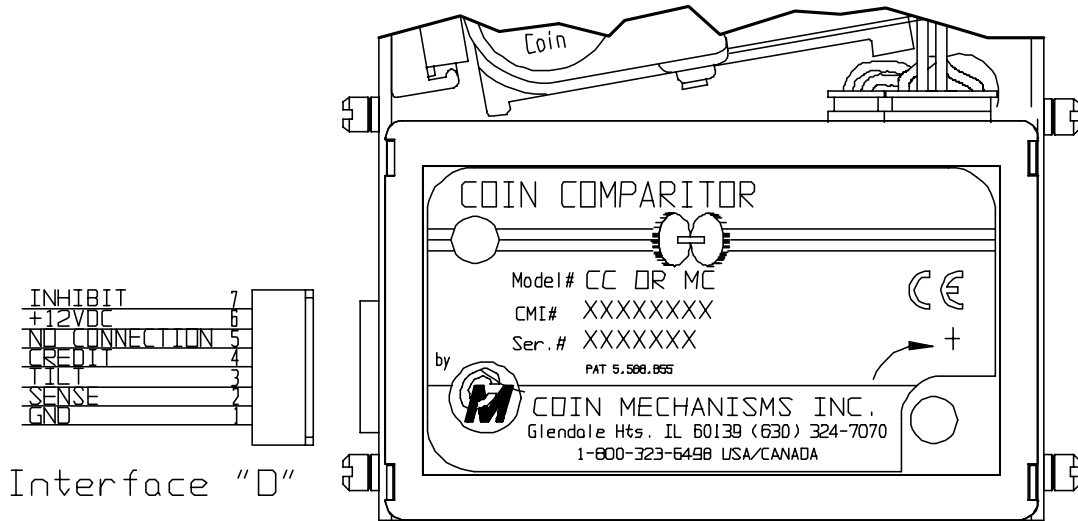
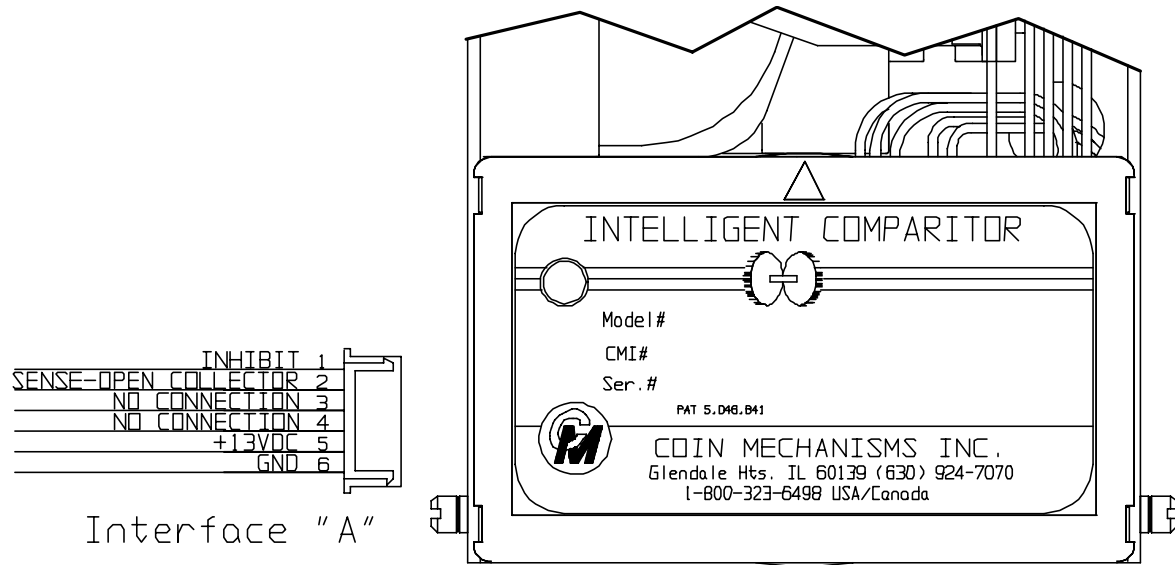
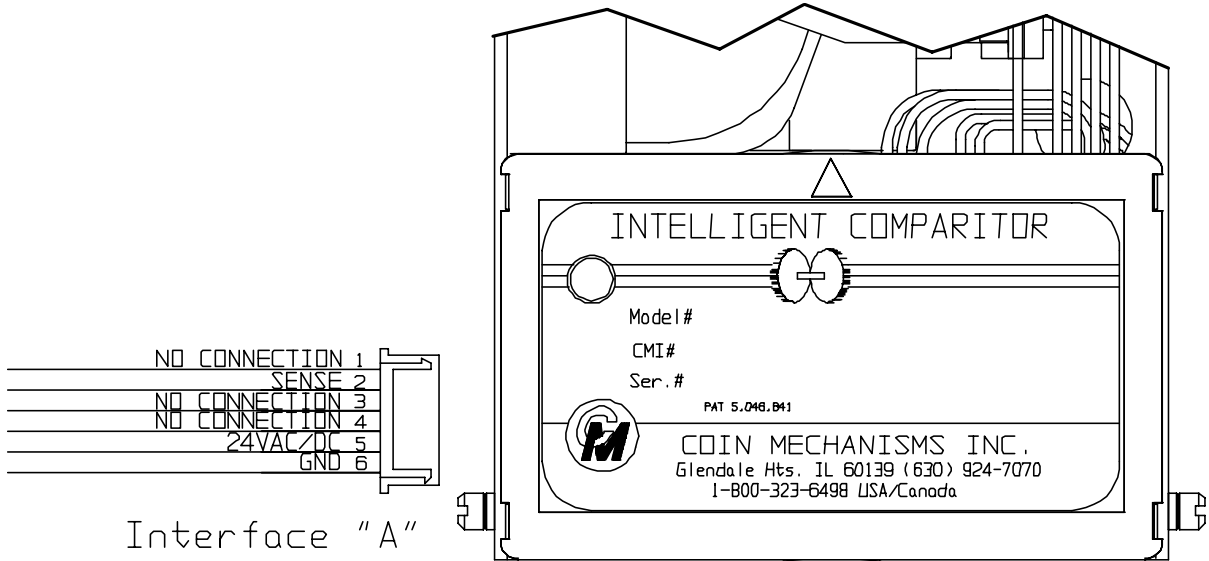


FIG #15
IC-32 , IC-36

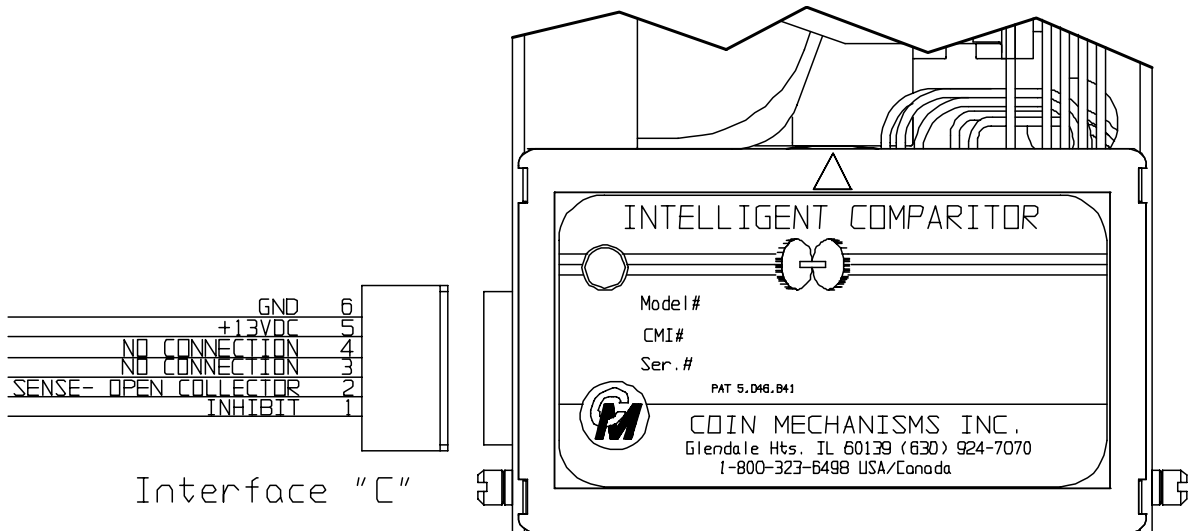


COIN COMPARITOR PIN NUMBER IDENTIFICATION

**FIG #16
IC-33 , IC-37**

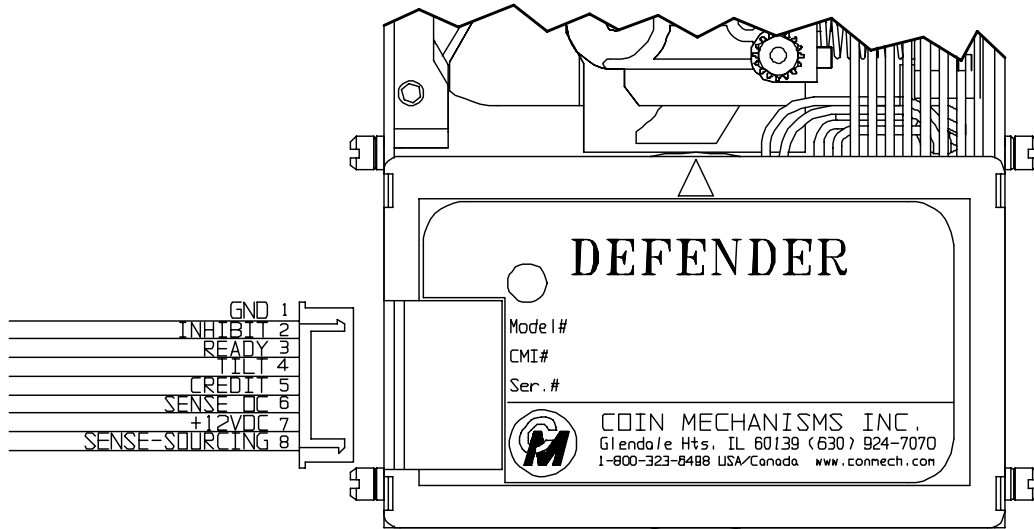


**FIG #17
CC-16 , IC-16
13VDC INH**



COIN COMPARITOR PIN NUMBER IDENTIFICATION

**FIG #18
DEFENDER**



COIN COMPARITOR TEST POINT IDENTIFICATION

FIG #19

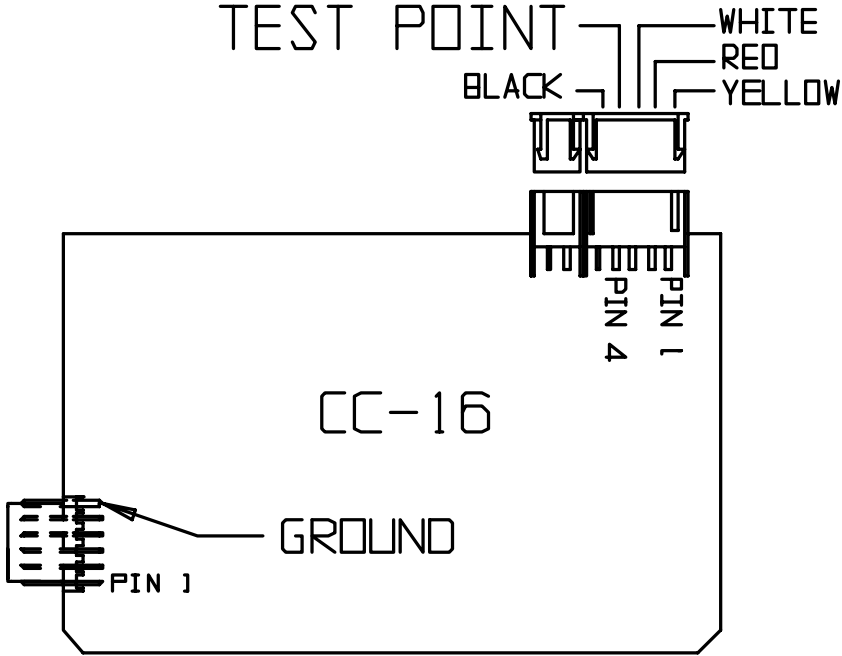
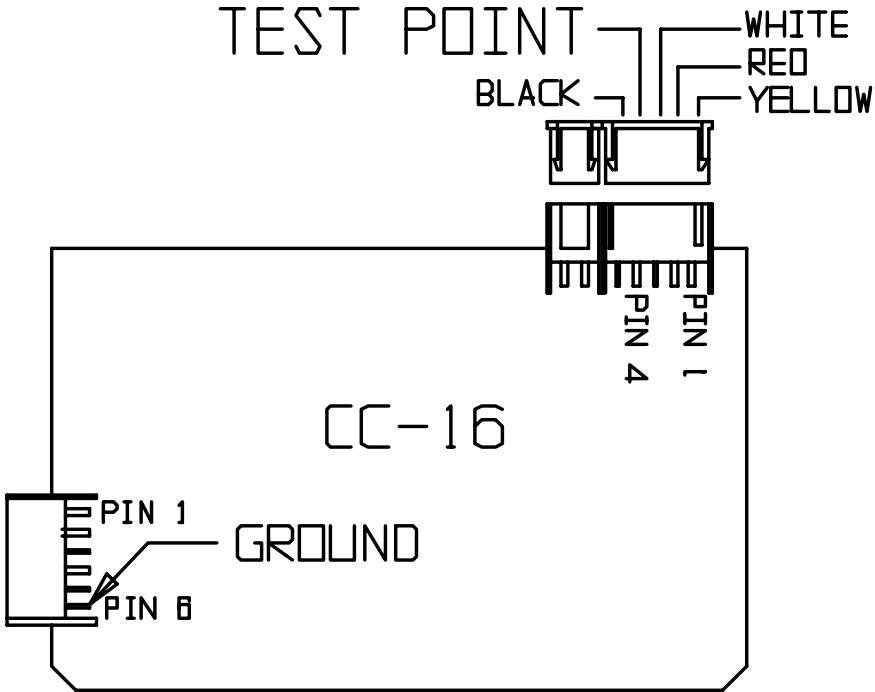


FIG #20



COIN COMPARITOR TEST POINT IDENTIFICATION

FIG #21

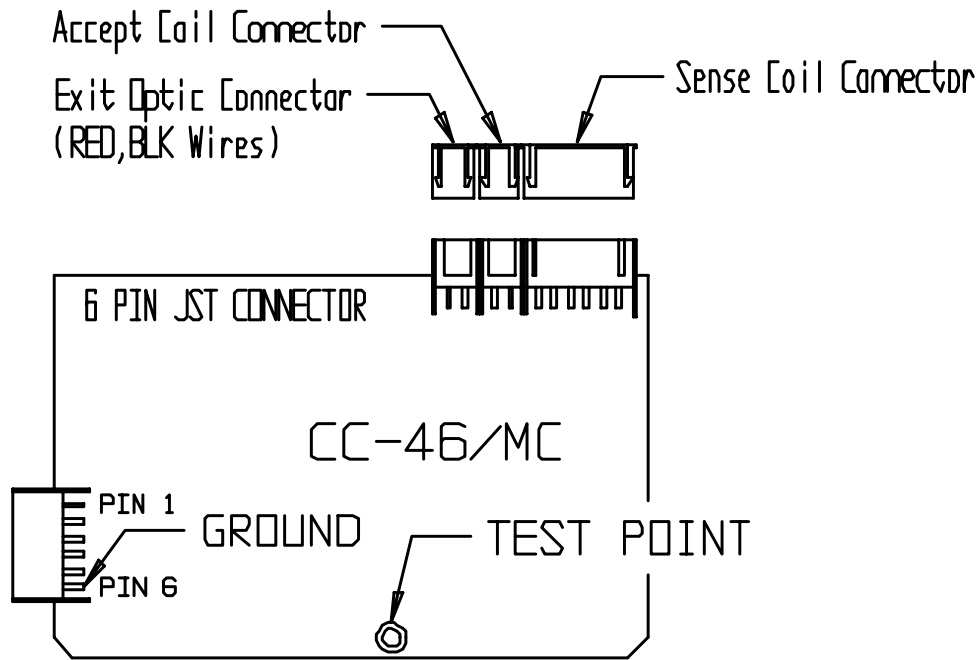
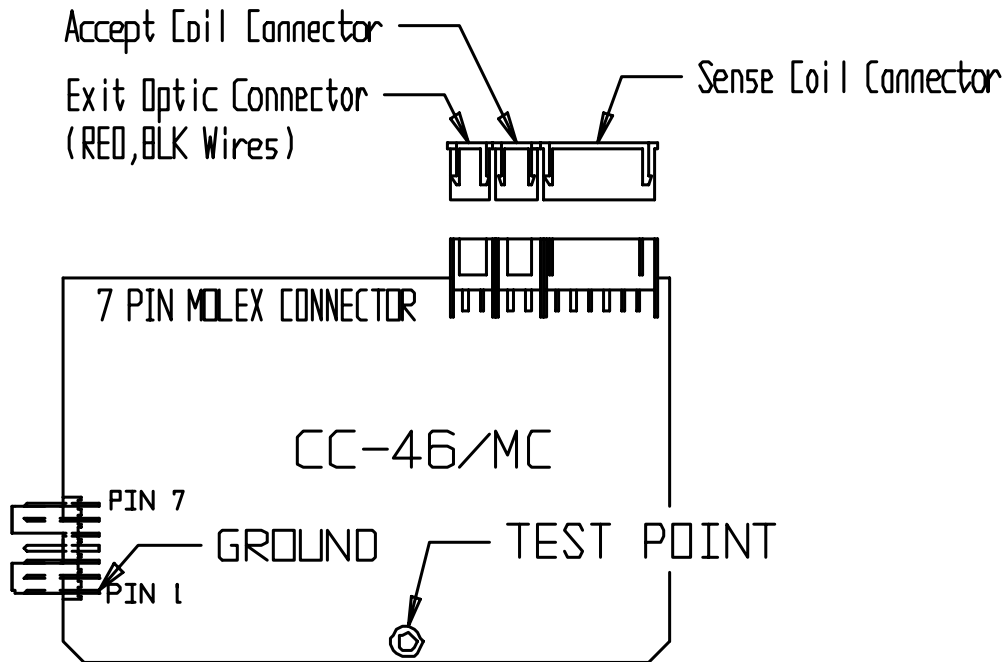


FIG #22



COIN COMPARITOR TEST POINT IDENTIFICATION

FIG #23

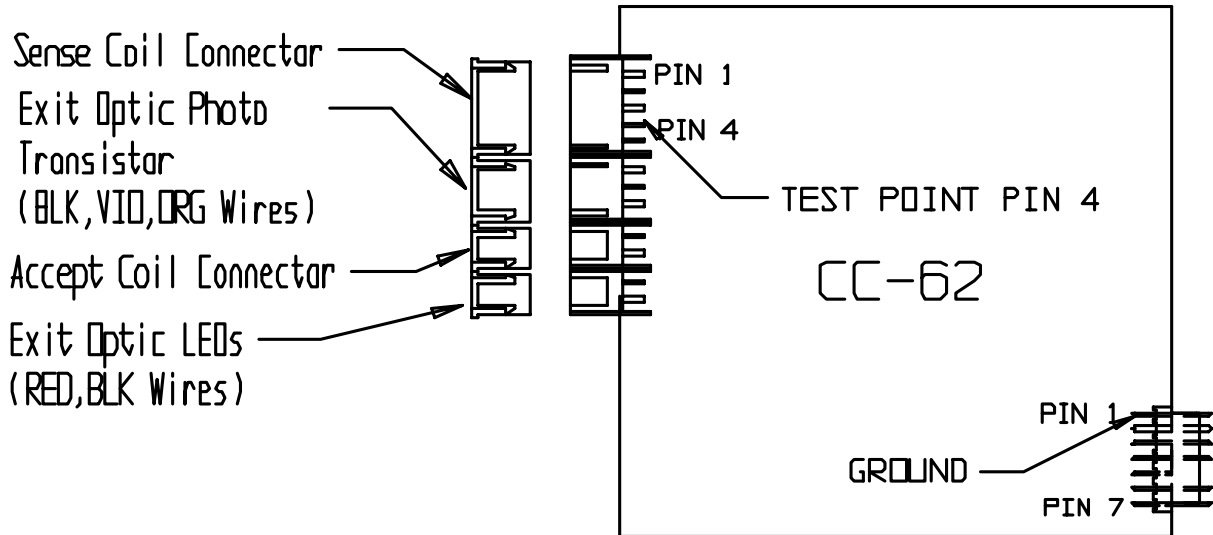
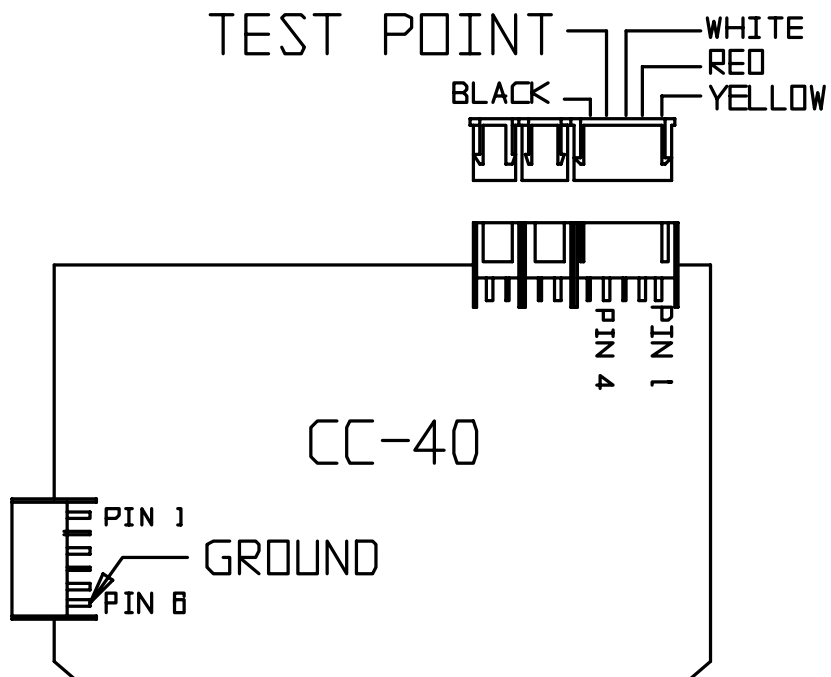


FIG #24



COIN COMPARITOR TEST POINT IDENTIFICATION

FIG #25

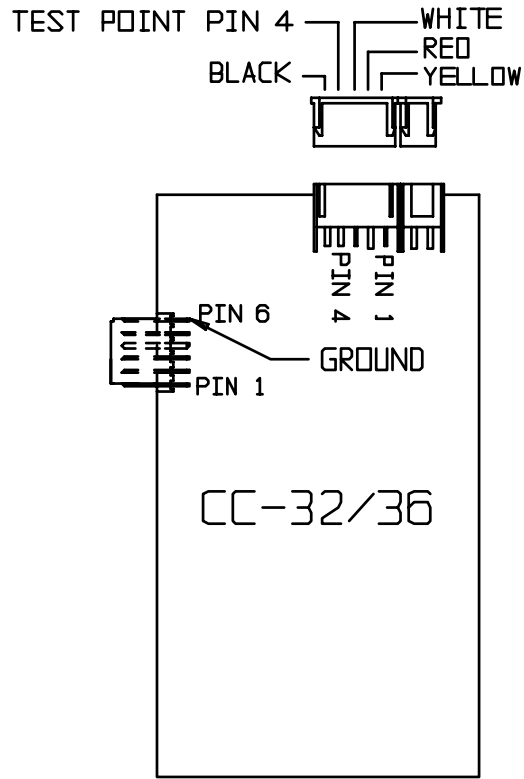
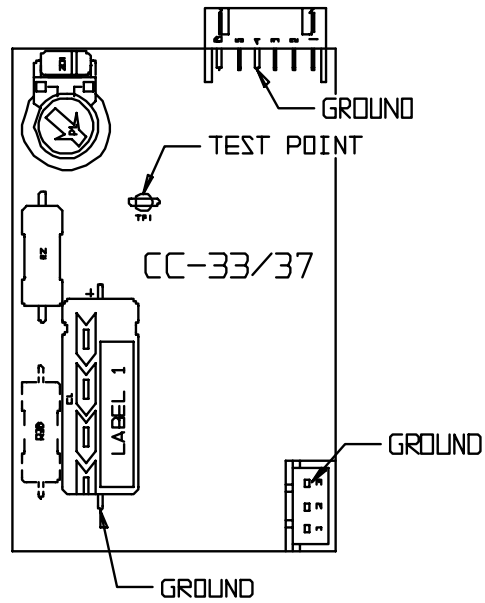


FIG #26



COIN COMPARITOR TEST POINT IDENTIFICATION

FIG #27
200 Series IC boards (e.g. 092702xx)

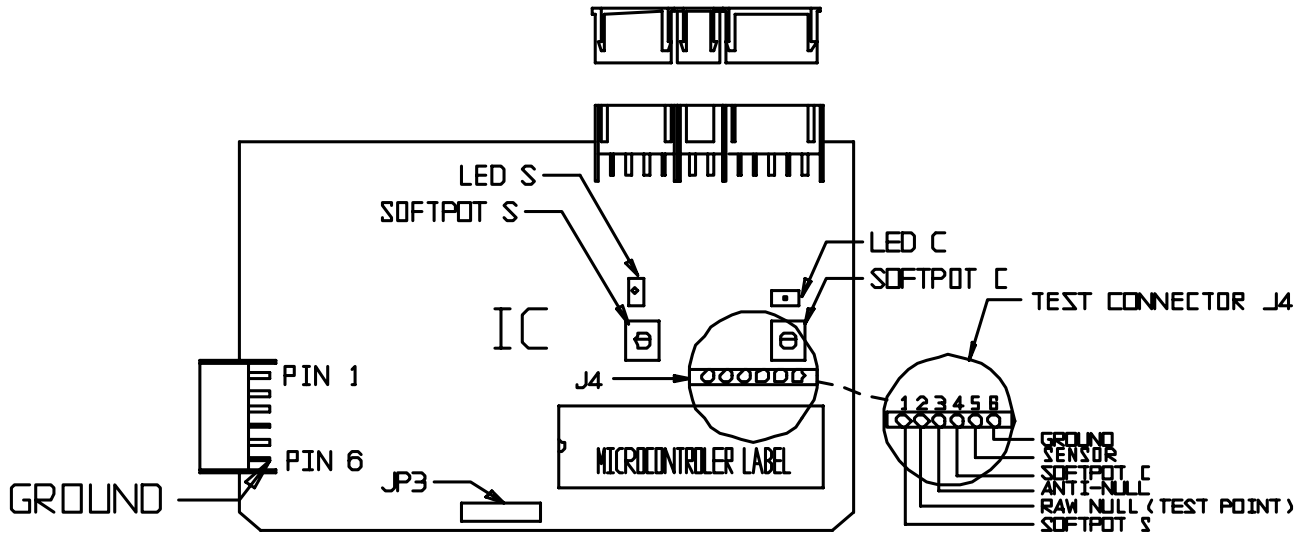
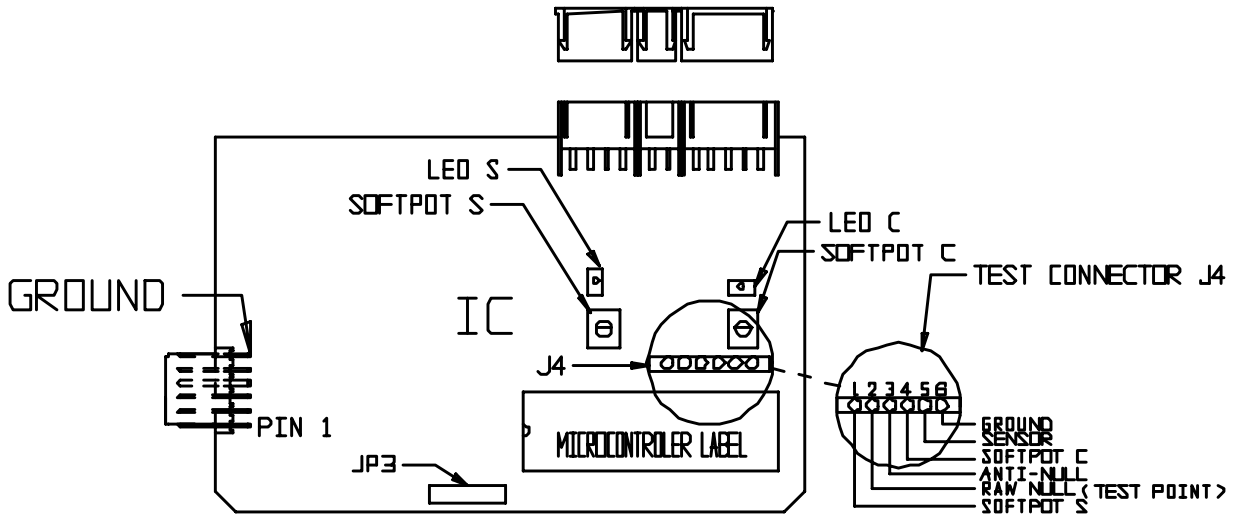


FIG #28
200 Series IC boards (e.g. 092702xx)



COIN COMPARITOR TEST POINT IDENTIFICATION

FIG #29
300 Series IC boards (e.g. 092703xx)

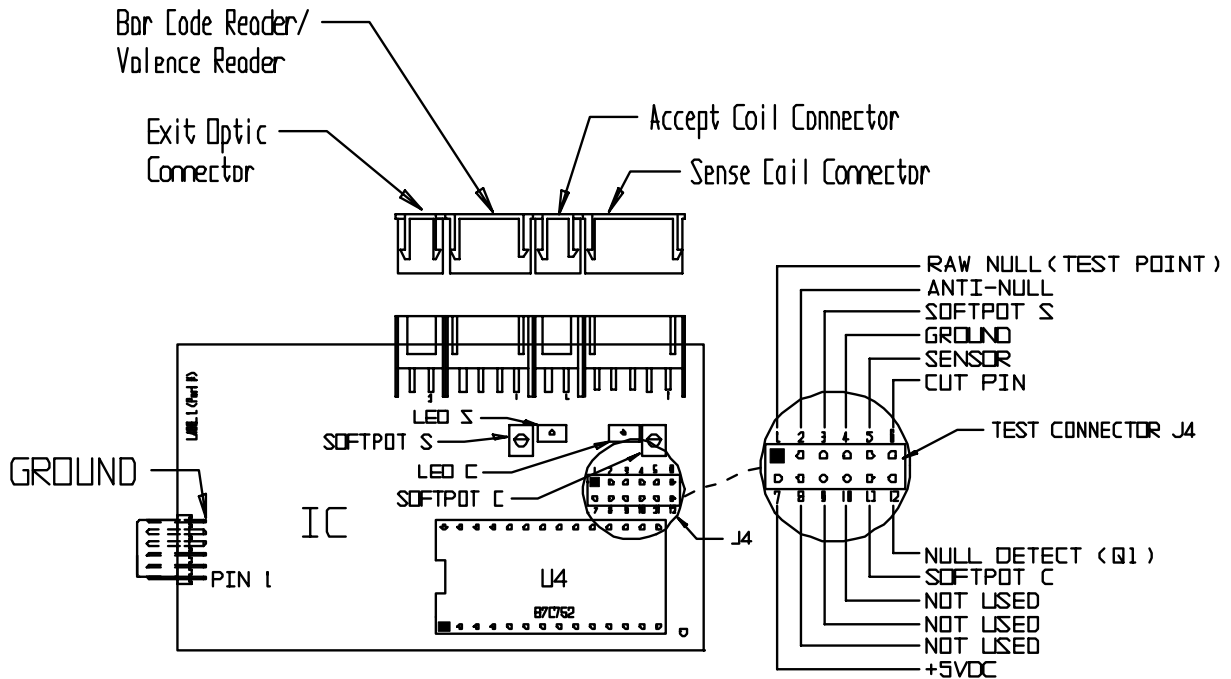
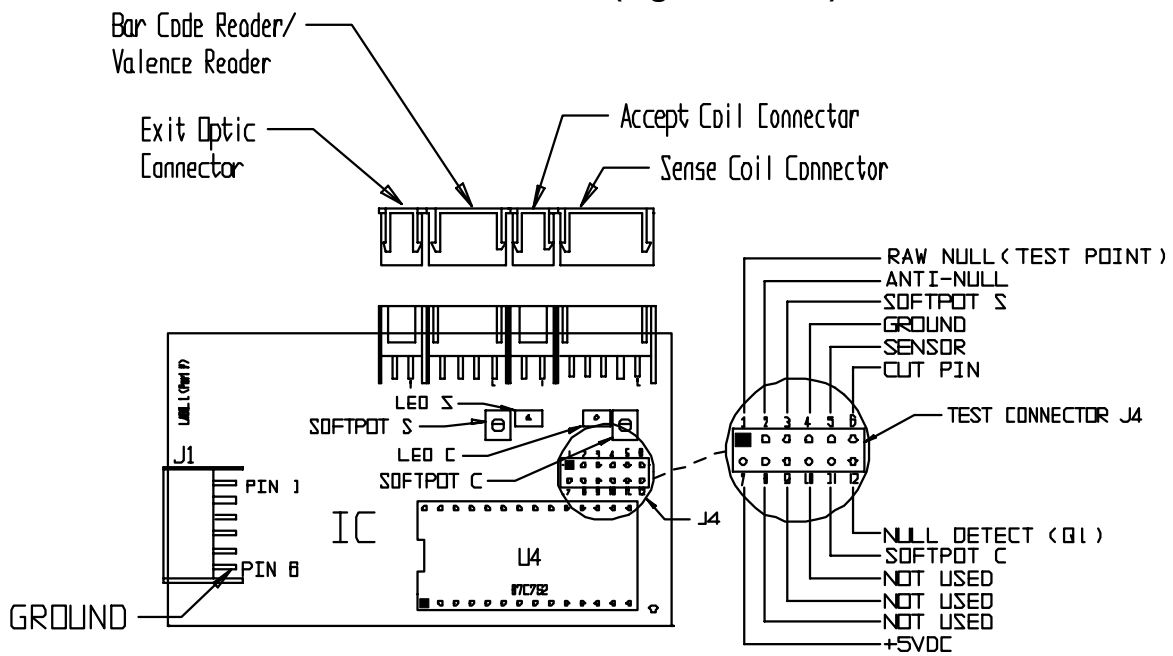


FIG #30
300 Series IC boards (e.g. 092703xx)



COIN COMPARITOR TEST POINT IDENTIFICATION

FIG #31
400 Series IC boards (e.g. 092704xx)

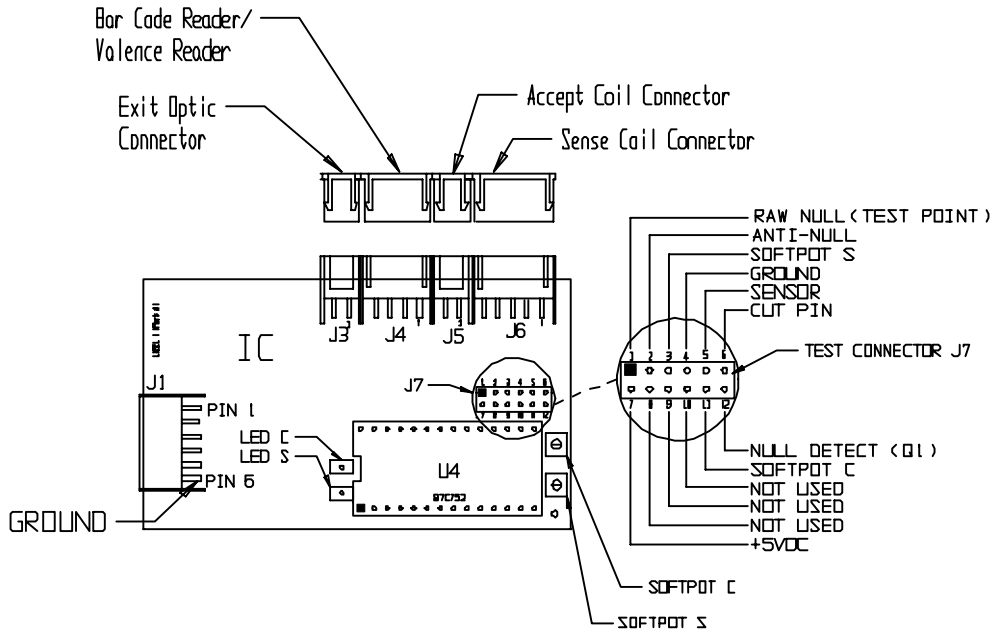
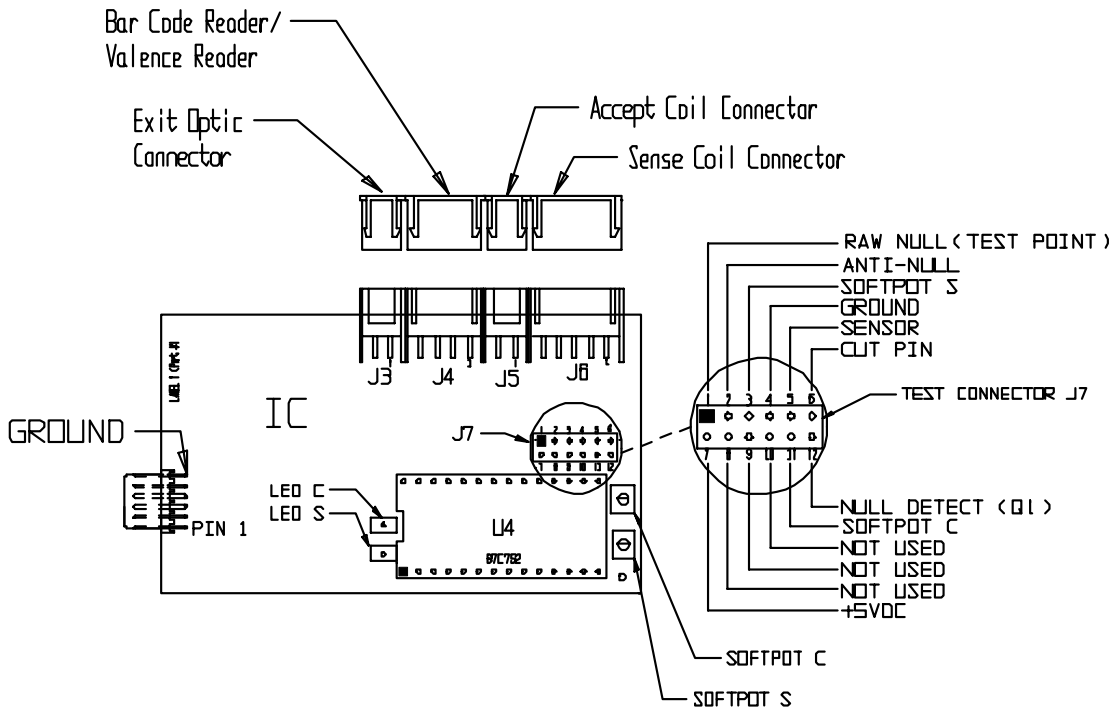


FIG #32
400 Series IC boards (e.g. 092704xx)



COIN COMPARITOR TEST POINT IDENTIFICATION

FIG #33
7000 Series IC boards (e.g. 0927-007xxx)

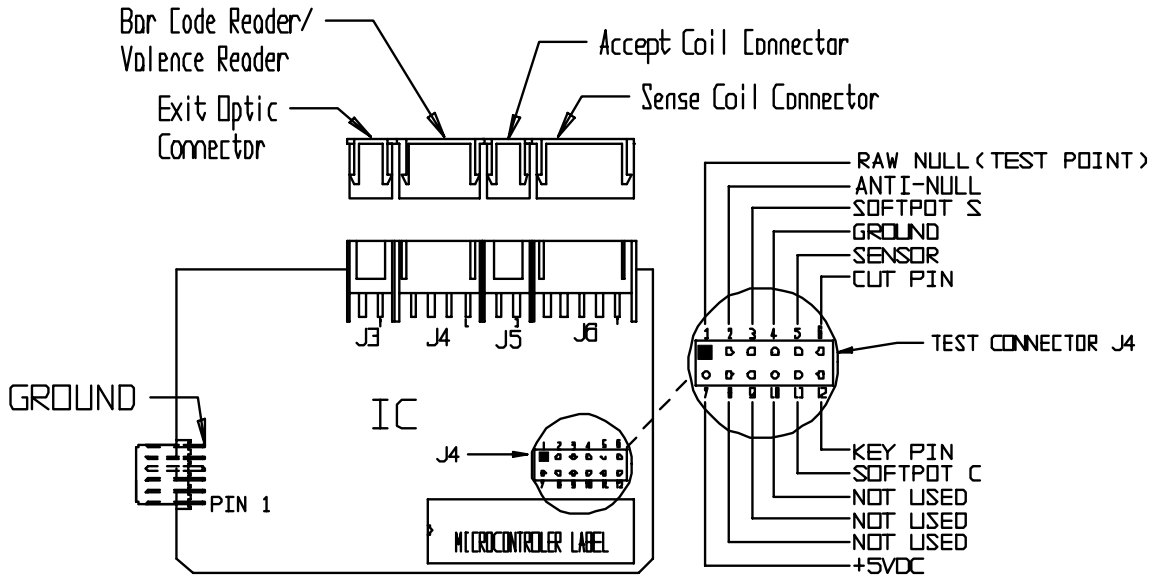
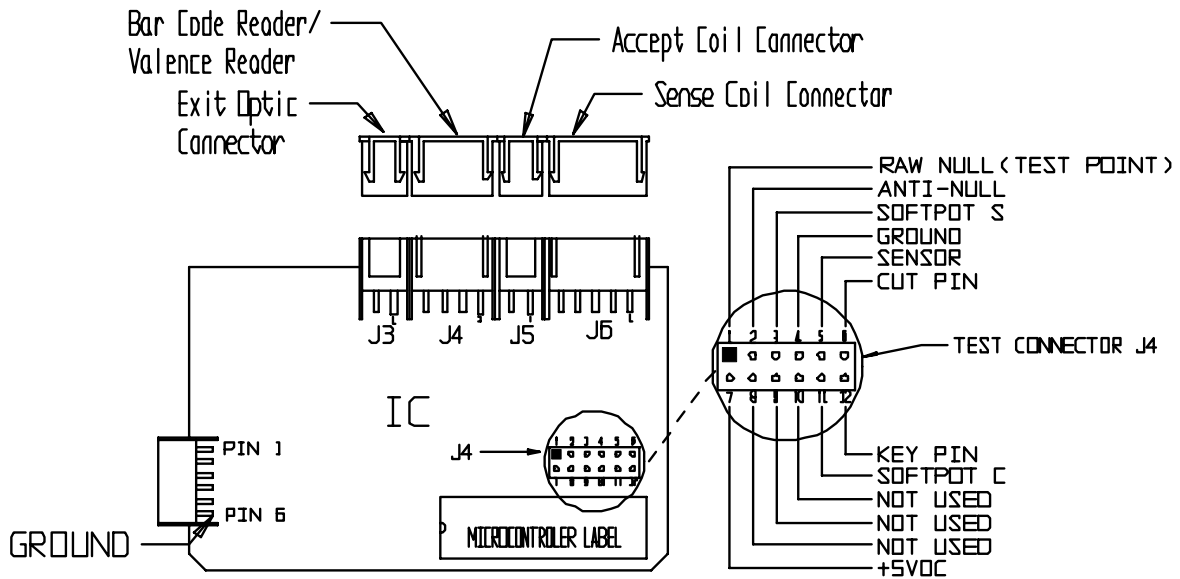


FIG #34
7000 Series IC boards (e.g. 0927-007xxx)



COIN COMPARITOR TEST POINT IDENTIFICATION

FIG #35

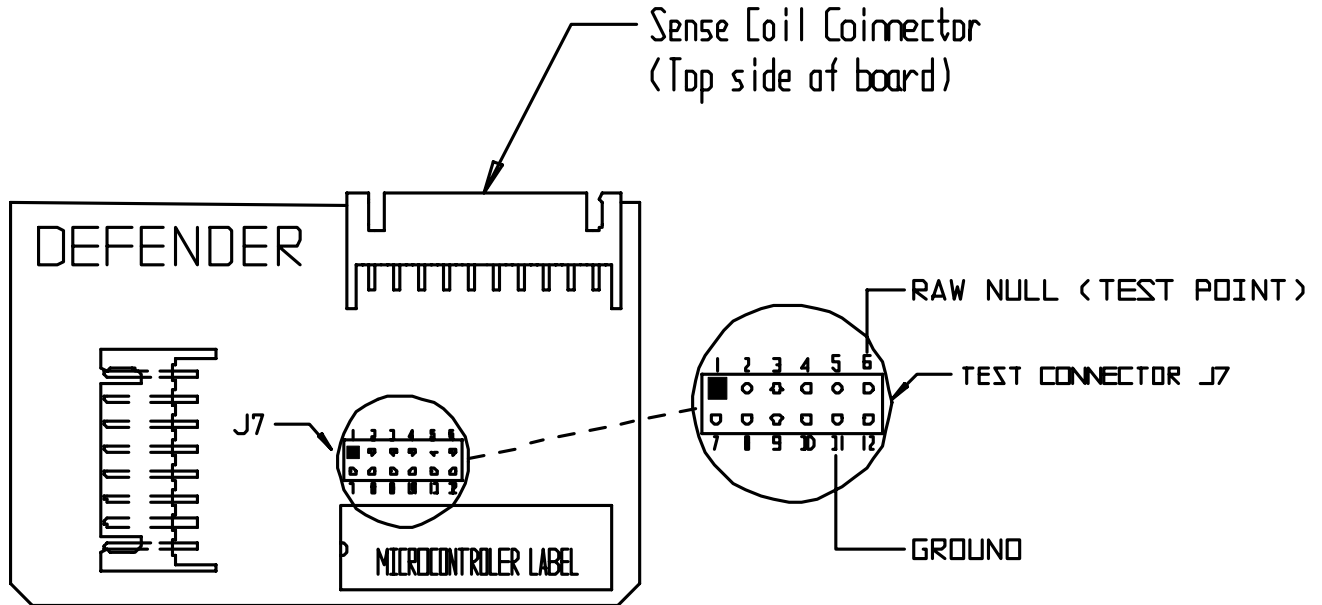
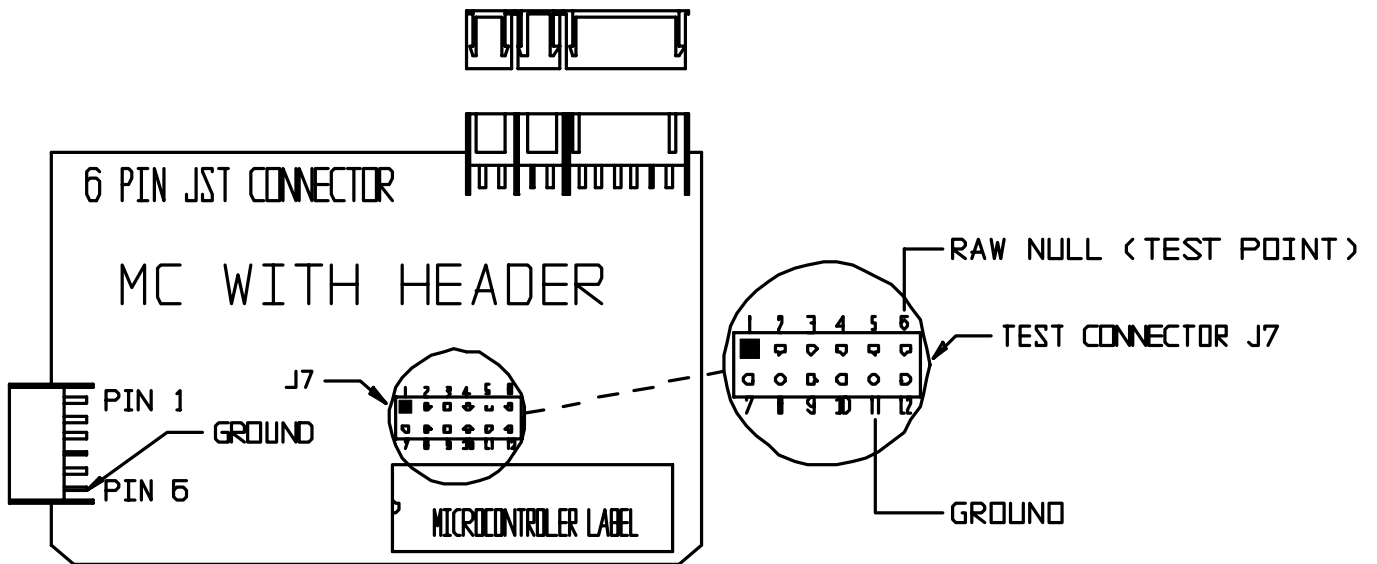
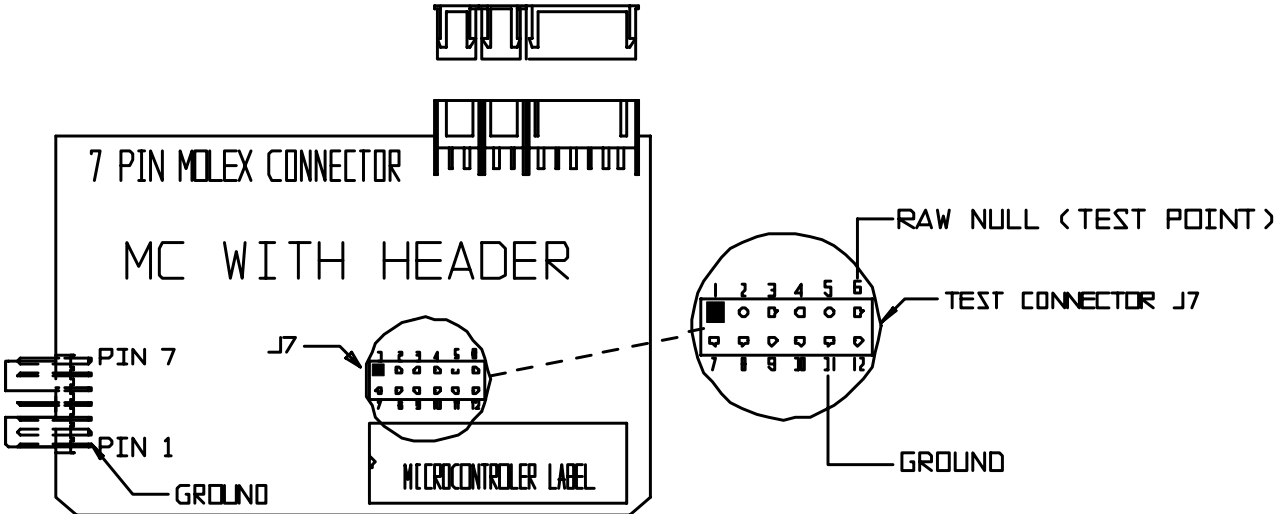


FIG #36

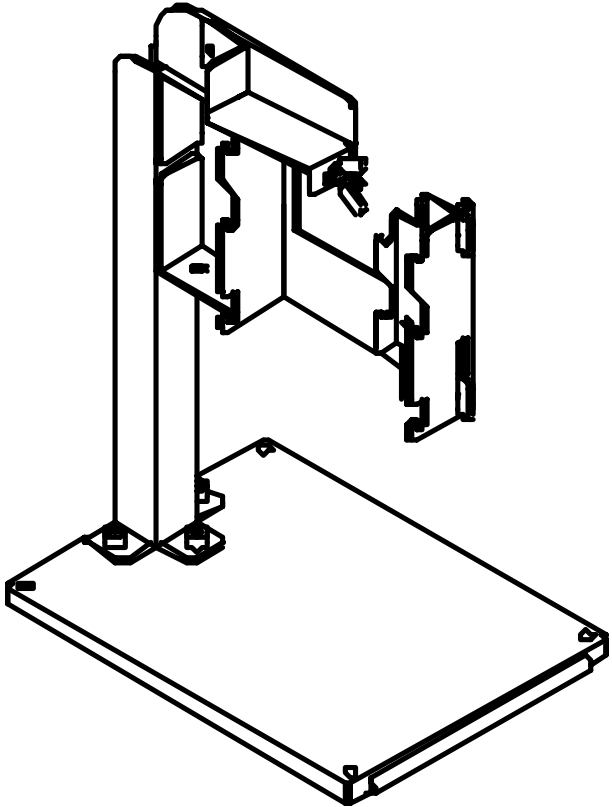


COIN COMPARITOR TEST POINT IDENTIFICATION

FIG #37



Test Stand Part number 0500009



Damper Weight Recommendation For Coin Comparitor® & Micro Comparitor®

Coin Weight vs. Damper Weight

When dealing with small, lightweight coins, which have copper compositions in them, like the US dime, it is recommended that a small mounting stud weight be used such as the mounting stud from the mainplate assembly. This small stud weight versus no weight will prevent other somewhat larger copper composition coins to be accepted as dimes. This condition can be applied to other unwanted coins, which have similar metal alloys and are slightly larger in diameter.

Coin Weight Range in grams	Section 1.01 <u>Typical</u> <u>coin used</u>	Damper Weight Assembly No.
1.5 to 1.9	Small coins / tokens	06660024 = "No Weight"
2.0 to 2.9	1¢, 10	06660051 = 0.7 grams
3.0 to 4.4	5¢ , 25¢	06660012 = 2.6 grams
4.5 to 5.0	Canadian 25¢	06660101 = 4.0 grams
5.0 to 8.5	25¢, Token	06660013 = 6.0 grams
8.5 to 10.0	Canadian \$1	06660102 = 9.0 grams
10.0 to 10.5	Special coins	06660056 = 10.6 grams
10.5 to 11.0	Australian Dollar	06660046 = 12.0 grams
11.0 to and up	50¢ / \$ Game Tokens	06660014 = 14.2 grams
11.0 to and up	1.47" and up dia. only	06660076 = 14.2 grams

The damper weight is utilized in conjunction with a lever arm in the Comparitor coin chute to bias the falling coin against a reference surface (the rail) in order to closely align the coin with the resident coin so that an accurate comparison can be made by the sensor coils and associated electronics.

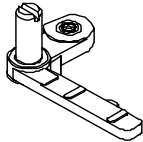
To establish a repeatable test for damper weight specifications, the chart above was determined dropping coins from a "static" position at the coin entry. A minimum weight coin was determined to overcome and pivot the damper lever when let go from this static position. This minimum weight established the coin weight range for each damper weight.

In real in-situ applications the initial height of the falling coin, and therefore its speed and striking force on the lever, will have differing consequences on the Comparitor's performance for accepting valid coins and rejecting fraud coins. In some cases, excessive rejection of valid coins may be remedied by using the next higher damper weight. However, using too heavy of a weight can slow the coin significantly to where it will be rejected because of a time out.

This chart was established as a guideline only and may be deviated from for special coin / token and machine circumstances.

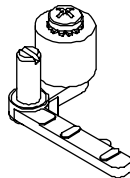
DAMPER LEVER WEIGHT AND HARDWARE CHART For CC / MC Product

NO WEIGHT

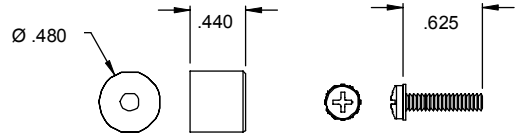


P/N 06660024

9 G



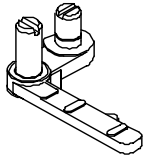
P/N 06660102



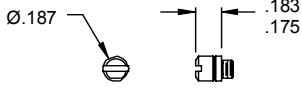
P/N 04060083-02
WEIGHT, DAMPER, 9 GRAM

P/N P-166-6-10
SCREW, 6-32 X 5/8,
PHIL, PH, W/SEMS

.7G

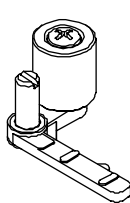


P/N 06660051

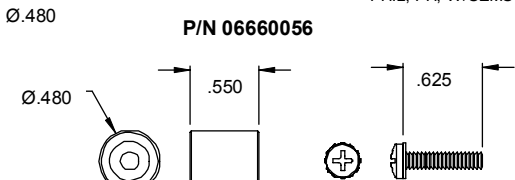


P/N 04060005-01
STUD, #6 MTG, .7 GRAM,
CLEAR FINISH

10.6 G



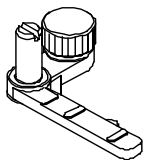
P/N 06660056



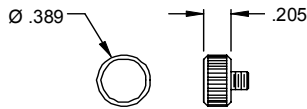
P/N 04060081-02
WEIGHT, DAMPER, 10.6 GRAM
YELLOW FINISH

P/N P-166-6-10
SCREW, 6-32 X 5/8,
PHIL, PH, W/SEMS

2.6 G

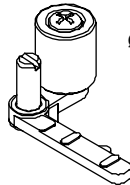


P/N 06660012

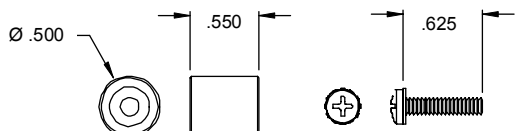


P/N 04060038-01
WEIGHT, DAMPER, 2.6 GRAM
CLEAR FINISH

12 G



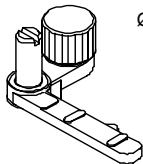
P/N 06660046



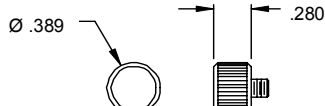
P/N 04060080-02
WEIGHT, DAMPER, 12 GRAM
YELLOW FINISH

P/N P-166-6-10
SCREW, 6-32 X 5/8,
PHIL, PH, W/SEMS

4 G

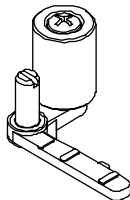


P/N 06660101

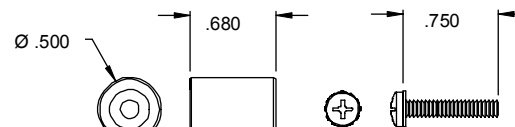


P/N 04060084-02
WEIGHT, DAMPER, 4 GRAM
YELLOW FINISH

14 G



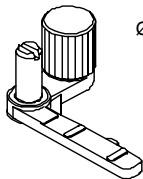
P/N 06660014



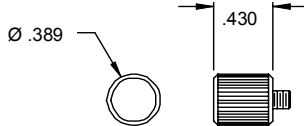
P/N 04060040-01
WEIGHT, DAMPER, 14 GRAM
CLEAR FINISH

P/N P-166-6-12
SCREW, 6-32 X 3/4,
PHIL, PH, W/SEMS

6 G

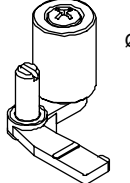


P/N 06660013

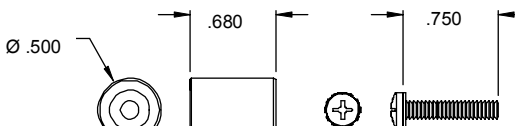


P/N 04060039-01
WEIGHT, DAMPER, 6 GRAM
CLEAR FINISH

14 G



P/N 06660076



P/N 04060040-01
WEIGHT, DAMPER, 14 GRAM
CLEAR FINISH

P/N P-166-6-12
SCREW, 6-32 X 3/4,
PHIL, PH, W/SEMS

Universal Test Station II ACCESSORIES

Customer Interfaces

<u>Part Number</u>	<u>Description</u>
0928-000128	I/F,ASM,TS,12V,8JST,INH-HI
0928-000134	I/F,ASM,TS,12V,7MLX,INH-HI,SOC
0928-000137	I/F,ASM,TS,12V,6JST,INH-LO,S—
0928-000138	I/F,ASM,TS,12V,6JST,INH-NO,SSR
0928-000139	I/F,ASM,TS,12V,6JST,INH-HI,SSR
0928-000140	I/F,ASM,TS,12V,6JST,INH-HI,SOC
0928-000141	I/F,ASM,TS,24V,6JST,INH-NO,SSR
0928-000142	I/F,ASM,TS,12V,6JST,INH-HI,S—
0928-000143	I/F,ASM,TS,24V,6JST,INH-HI,S—
0928-000144	I/F,ASM,TS,12V,3JST,INH-NO,SSR
0928-000145	I/F,ASM,TS,24V,6JST,INH-LO,S—
0928-000153	I/F,ASM,TS,12V,6MLX,INH-HI,SOC
0928-000154	I/F,ASM,TS,12V,7MLX,INH-LO,SOC
0928-000155	I/F,ASM,TS,12V,7MLX,INH-HI,SSR
0928-000156	I/F,ASM,TS,24V,3JST,INH-NO,SSR
0928-000157	I/F,ASM,TS,12V,8JST,INH-LO
0928-000158	I/F,ASM,TS,12V,8JST,INH-LO,REV
0928-000159	I/F,ASM,TS,12V,8JST,INH-HI,REV
0928-000168	I/F,ASM,TS,12V,7MLX,INH HI,SOC,REV

Test Interfaces

<u>Part Number</u>	<u>Description</u>
0928-000132	I/F,ASM,TS,12PIN,TEST HEADER, DEF3,MC2

Tools

Sensor Coil Gapping Tools

<u>Part Number</u>	<u>Description</u>
04700026	GAUGE,DEFEND,COIL SETTING,.085
04700027	GAUGE,DEFEND,COIL SETTING,.130
04700033	GAUGE,DEFEND,COIL SETTING,.102

Hex Key Adjustment Tools

<u>Part Number</u>	<u>Description</u>
05090004	TOOL,ADJ,LONG,IMPRINTED
05090023	TOOL,ADJ,DEFENDER

Replacement Fuses

<u>Part Number</u>	<u>Description</u>
0813-000010	FUSE,2.0AMP,250V,FAST-ACTING, 3AG,0.25 X 1.25

Power Cord

<u>Part Number</u>	<u>Description</u>
0821-009101	CORD,POWER,90 DEGREE

Defender Diagnostic Tester

<u>Part Number</u>	<u>Description</u>
00660013	TESTER,DEFENDER

Universal Test Station II User Manual

<u>Part Number</u>	<u>Description</u>
09300348	DEFENDER USER MANUAL

FRONT PANEL LAYOUT

