

STARVILLE

xBrick Full-Colour
16×3W

LED floodlight

Musikhaus Thomann
Thomann GmbH
Hans-Thomann-Straße 1
96138 Burgebrach
Germany
Telephone: +49 (0) 9546 9223-0
E-mail: info@thomann.de
Internet: www.thomann.de

17.08.2015, ID: 259187 (V2)

Table of contents

1	General information	5
	1.1 Further information.....	6
	1.2 Notational conventions.....	7
	1.3 Symbols and signal words.....	9
2	Safety instructions	11
3	Installation	16
4	Starting up	20
5	Components and functions	23
6	Operating	26
	6.1 Starting the device.....	26
	6.2 Main menu.....	26
	6.3 Menu overview.....	32
	6.4 Functions in 5-channel DMX mode.....	33
	6.5 Functions in 13-channel DMX mode.....	34
7	Technical specifications	36

8	Plug and connection assignments.....	37
9	Troubleshooting.....	38
10	Cleaning.....	40
11	Protecting the environment.....	41

1 General information

This manual contains important instructions for the safe operation of the unit. Read and follow the safety instructions and all other instructions. Keep the manual for future reference. Make sure that it is available to all those using the device. If you sell the unit please make sure that the buyer also receives this manual.

Our products are subject to a process of continuous development. Thus, they are subject to change.

1.1 Further information

On our website (www.thomann.de) you will find lots of further information and details on the following points:

Download	This manual is also available as PDF file for you to download.
Keyword search	Use the search function in the electronic version to find the topics of interest for you quickly.
Online guides	Our online guides provide detailed information on technical basics and terms.
Personal consultation	For personal consultation please contact our technical hotline.
Service	If you have any problems with the device the customer service will gladly assist you.

1.2 Notational conventions

This manual uses the following notational conventions:

Letterings

The letterings for connectors and controls are marked by square brackets and italics.

Examples: *[VOLUME]* control, *[Mono]* button.

Displays

Texts and values displayed on the device are marked by quotation marks and italics.

Examples: *'24ch'*, *'OFF'*.

Instructions

The individual steps of an instruction are numbered consecutively. The result of a step is indented and highlighted by an arrow.

Example:

1. ▶ Switch on the device.
2. ▶ Press *[Auto]*.
 - ⇒ Automatic operation is started.
3. ▶ Switch off the device.

Cross-references



References to other locations in this manual are identified by an arrow and the specified page number. In the electronic version of the manual, you can click the cross-reference to jump to the specified location.

Example: See ↗ *'Cross-references'* on page 8.

1.3 Symbols and signal words

In this section you will find an overview of the meaning of symbols and signal words that are used in this manual.

Signal word	Meaning
DANGER!	This combination of symbol and signal word indicates an immediate dangerous situation that will result in death or serious injury if it is not avoided.
WARNING!	This combination of symbol and signal word indicates a possible dangerous situation that can result in death or serious injury if it is not avoided.
NOTICE!	This combination of symbol and signal word indicates a possible dangerous situation that can result in material and environmental damage if it is not avoided.

Warning signs	Type of danger
 A yellow triangular warning sign with a black border and a black lightning bolt symbol in the center.	Warning – high-voltage.
 A yellow triangular warning sign with a black border and a black symbol of a person standing next to a suspended load.	Warning – suspended load.
 A yellow triangular warning sign with a black border and a black exclamation mark in the center.	Warning – danger zone.

2 Safety instructions

Intended use

This device is intended to be used as an electronic illumination effect using LED technics. The device is designed for professional use and is not suitable for use in households. Use the device only as described in this user manual. Any other use or use under other operating conditions is considered to be improper and may result in personal injury or property damage. No liability will be assumed for damages resulting from improper use.

This device may be used only by persons with sufficient physical, sensorial, and intellectual abilities and having corresponding knowledge and experience. Other persons may use this device only if they are supervised or instructed by a person who is responsible for their safety.

Safety



DANGER!

Danger for children

Ensure that plastic bags, packaging, etc. are disposed of properly and are not within reach of babies and young children. Choking hazard!

Ensure that children do not detach any small parts (e.g. knobs or the like) from the unit. They could swallow the pieces and choke!

Never let children unattended use electrical devices.



DANGER!

Electric shock caused by high voltages inside

Within the device there are areas where high voltages may be present. Never remove any covers.

There are no user-serviceable parts inside.

Do not use the device if covers, protectors or optical components are missing or damaged.



DANGER!

Electric shock caused by short-circuit

Always use proper ready-made insulated mains cabling (power cord) with a protective contact plug. Do not modify the mains cable or the plug. Failure to do so could result in electric shock/death or fire. If in doubt, seek advice from a registered electrician.



WARNING!

Eye damage caused by high light intensity

Never look directly into the light source.



WARNING!

Risk of epileptic shock

Strobe lighting can trigger seizures in photosensitive epilepsy. Sensitive persons should avoid looking at strobe lights.



NOTICE!

Risk of fire

Do not cover the device nor any ventilation slots. Do not place the device near any direct heat source. Keep the device away from naked flames.



NOTICE!

Operating conditions

This device has been designed for indoor use only. To prevent damage, never expose the device to any liquid or moisture. Avoid direct sunlight, heavy dirt, and strong vibrations.



NOTICE!

Power supply

Before connecting the device, ensure that the input voltage (AC outlet) matches the voltage rating of the device and that the AC outlet is protected by a residual current circuit breaker. Failure to do so could result in damage to the device and possibly injure the user.

Unplug the device before electrical storms occur and when it is unused for long periods of time to reduce the risk of electric shock or fire.

3 Installation

Unpack and carefully check that there is no transportation damage before using the unit. Keep the equipment packaging. To fully protect the device against vibration, dust and moisture during transportation or storage use the original packaging or your own packaging material suitable for transport or storage, respectively.



WARNING!

Risk of injury caused by falling objects

Make sure that the installation complies with the standards and rules that apply in your country. Always secure the device with a secondary safety attachment, such as a safety cable or a safety chain.



NOTICE!

Risk of overheating

Always ensure sufficient ventilation.

The ambient temperature must always be below 40 °C (104 °F).



NOTICE!

Use of stands

When mounting the device onto a stand, ensure that the stand is in a safe and stable position and that the weight of the device does not exceed the maximum permissible load capacity of the stand.



NOTICE!

Possible data transmission errors

For error-free operation make use of dedicated DMX cables and do not use ordinary microphone cables.

Never connect the DMX input or output to audio devices such as mixers or amplifiers.

Mounting options

You can install the device standing or hanging upside down. When in use, the device must be mounted at a solid surface or clamped to an approved truss. Use the openings of the two-piece bracket provided for mounting.

Always work from a stable platform whenever installing, moving or servicing the unit. Block access under the work area.

The safety cable must be attached to the safety eyelet (↪ *Chapter 5 'Components and functions' on page 23*).



Please note that this device must not be connected to a dimmer.

4 Starting up

Establish all connections as long as the unit is switched off. Use the shortest possible high-quality cables for all connections.

Connections in DMX mode

Connect the DMX input of the device to the DMX output of a DMX controller or another DMX device. Connect the output of the first DMX device to the input of the second one, and so on to form a daisy chain. Always ensure that the output of the last DMX device in the daisy chain is terminated with a resistor ($110\ \Omega$, $\frac{1}{4}\ \text{W}$).

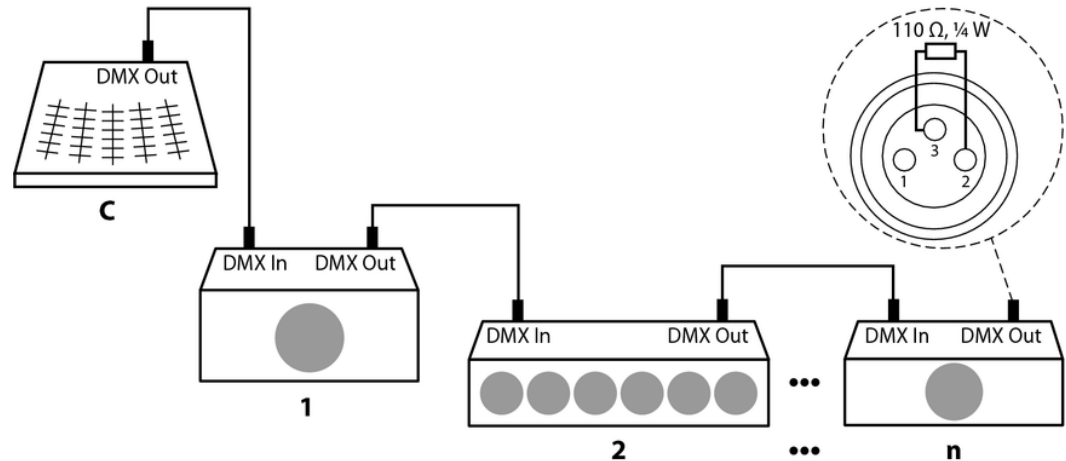

Connections in master/slave mode

When you configure a group of devices in master/slave mode, the first unit will control the other units for an automatic, sound-activated, synchronized show. This function is ideal when you want to start a show immediately. Connect the DMX output of the master device to the DMX input of the first slave device. Then connect the DMX output of the first slave device to the DMX input of the second slave device and so on.

5 Components and functions

Rear panel

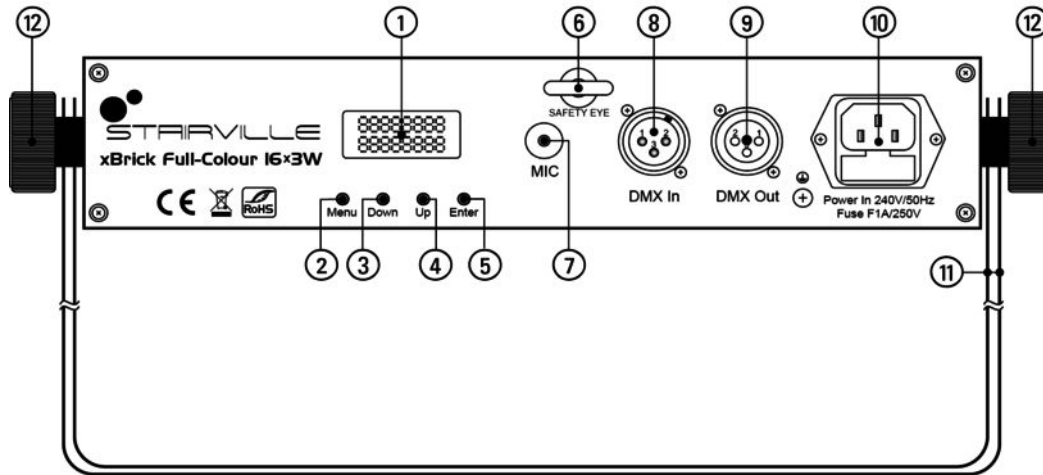

xBrick Full-Colour 16x3W

1	Display.
2	<i>[Menu]</i> To select the main menu and to store the changes made.
3	<i>[Down]</i> Decrements the displayed value by 1
4	<i>[Up]</i> Increments the displayed value by one.
5	<i>[Enter]</i> Selects an option of the respective operating mode.
6	Eyelet for safety cable.
7	<i>[MIC]</i> Microphone for sound control.

8	<i>[DMX In]</i> DMX input.
9	<i>[DMX Out]</i> DMX output.
10	<i>[Power In]</i> Plug for mains cable with fuse holder next to it. The input voltage range is printed below the plug.
11	Bracket for floor placement or hanging.
12	Locking screws for the mounting brackets.

6 Operating

6.1 Starting the device

Connect the device to the mains power supply, to start operation. After few seconds the display shows, that the unit executes a reset. After that the unit is ready for operation. If it is configured to operate as Master", an automatic light show begins. According to your previous selection, the display show *'Master Sound'*, *'Master Fade'* or *'Master Color'*.

6.2 Main menu

Briefly press the *[MENU]* button to select the main menu and the desired operating mode. Use the *[Up]* and *[Down]* buttons to change the respectively displayed value. When the display shows the desired value, press *[ENTER]*.

To store the changes / settings, press *[MENU]* for at least two seconds.

If you don't press any button for about 1 minute, the unit returns to the previously selected mode. The set values are retained even when the device is disconnected from the mains power supply.

DMX address



Repeatedly press the *[MENU]* button until the display shows 'DMX Address'. Press *[ENTER]*. Now you can set the number of the first DMX channel to be used by the device (DMX address). Use the *[Up]* and *[Down]* buttons to select a value between 1 and 512.

When the display shows the desired value, press the *[ENTER]* button to return to the main menu.

Make sure that this number matches the configuration of your DMX controller. The following table shows the highest possible DMX address for the various DMX modes

Mode	Highest possible DMX address
5 channels	508
13 channels	500

DMX mode



Repeatedly press the *[MENU]* button until the display shows '*Channel Mode*'. Press *[ENTER]*. Use the *[Up]* and *[Down]* buttons to select one of the following DMX operating modes: 5 channels ('*5 Ch Mode*') or 13 channels ('*13 Ch Mode*'). This setting is only relevant if the device is controlled via DMX.

When the display shows the desired value, press the *[ENTER]* button to return to the main menu or press and hold the *[MENU]* button for at least two seconds to change immediately to the DMX operating mode.

Master/slave operating mode



Repeatedly press the *[MENU]* button until the display shows '*Slave Mode*'. Press *[ENTER]*. Use the *[Up]* and *[Down]* buttons to select '*Master Mode*', '*Slave1 Mode*' and '*Slave 2 Mode*'.

When in Master/Slave operating mode, the master device and those connected devices configured as Slave 1 work synchronously. Those devices configured as Slave 2 work mirror-inverted to the master device.

When the display shows the desired value, press the *[ENTER]* button to return to the main menu.

Show mode



The automatic show can only be activated on the master device.

Repeatedly press the *[MENU]* button until the display shows 'Show Mode'. Press *[ENTER]*. Use the *[Up]* and *[Down]* buttons to select between

- 'Sound' (sound controlled show),
- 'Fade' (automatic show with adjustable fade effect), and
- 'Color' (automatic show with fast colour change)

When selecting Fade, press the *[ENTER]* button again. Use the *[Up]* and *[Down]* buttons to adjust the speed between 1 (fast) and 9 (slow).

When the display shows the desired value, press the *[MENU]* button for at least two seconds. The device shows an automatic show. According to your selection the display shows 'Master Sound', 'Master Fade' or 'Master Color'.

LCD backlight

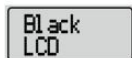

Repeatedly press the *[MENU]* button until the display shows 'Black LCD'. Press *[ENTER]*. Use the *[Up]* and *[Down]* buttons to choose between 'LCDLight On' and 'LCDLight Off'.

When the display shows the desired value, press the *[ENTER]* button to return to the main menu.

White balance

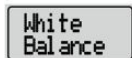

For each of the four LED groups you can separately adjust the composition of white colour from the basic colours red, green, and blue.

Repeatedly press the *[MENU]* button, until the display shows 'White Balance'. Press *[ENTER]*. Use the *[Up]* and *[Down]* buttons to choose between 'Red-1 Balance', 'Green-1 Balance', 'Blue-1 Balance', 'Red-2 Balance' and so on.

When the display shows the desired basic colour and LED group, press *[ENTER]*. Use the *[Up]* and *[Down]* buttons to enter a value between 0 et 255.

When the display shows the desired value, press *[ENTER]*.

Press *[MENU]* to return to the main menu.

Self test



Repeatedly press the *[MENU]* button, until the display shows 'Auto Test'. Press *[ENTER]*. Now the unit will execute a self test and show the basic colours red, green, blue, and subsequently white light.

Press *[ENTER]* to finish the self test and to return to the main menu.

Operating hours display

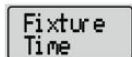

Repeatedly press the *[MENU]* button until the display shows 'Fixture Time'. Press *[ENTER]*. The display now shows the number of elapsed operating hours.

Press *[MENU]* to return to the main menu.

6.3 Menu overview

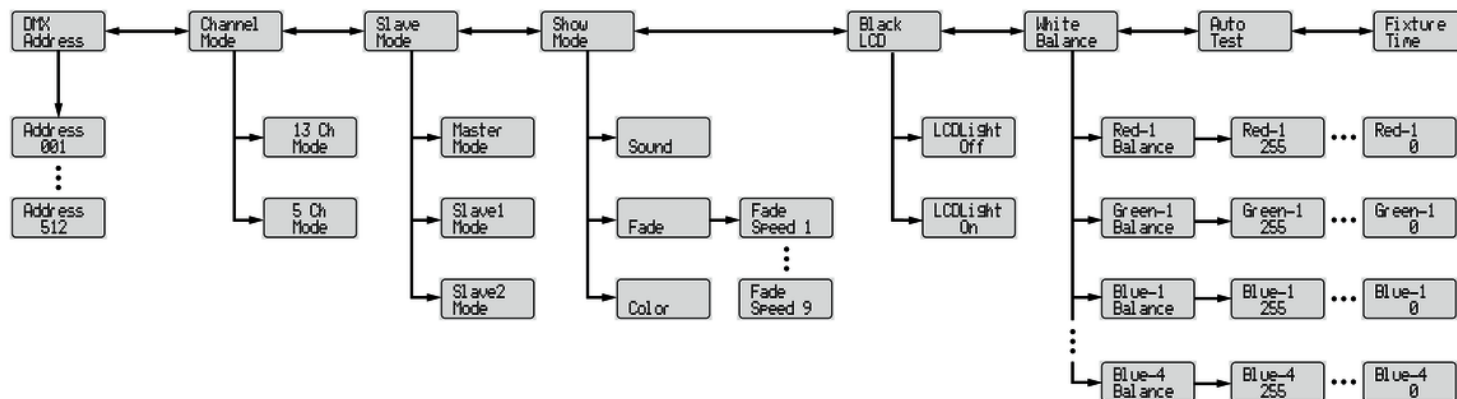

6.4 Functions in 5-channel DMX mode

Channel	Value	Function
1	0...255	Intensity red (0 % to 100 %)
2	0...255	Intensity green (0 % to 100 %)
3	0...255	Intensity blue (0 % to 100 %)
4	0...255	Main control (master dimmer, 0 % to 100 %)
5	0...255	Strobe effect (increasing speed)

6.5 Functions in 13-channel DMX mode

In this mode the 16 LEDs are divided into four groups of 4 LEDs each. Each of the channels 1 to 12 controls one basic colour of a group.

Channel	Value	LEDs	Function
1	0...255	1 to 4	Intensity red (0 % to 100 %)
2	0...255		Intensity green (0 % to 100 %)
3	0...255		Intensity blue (0 % to 100 %)
4	0...255	5 to 8	Intensity red (0 % to 100 %)
5	0...255		Intensity green (0 % to 100 %)
6	0...255		Intensity blue (0 % to 100 %)
7	0...255	9 to 12	Intensity red (0 % to 100 %)
8	0...255		Intensity green (0 % to 100 %)

Channel	Value	LEDs	Function
9	0...255		Intensity blue (0 % to 100 %)
10	0...255	13 to 16	Intensity red (0 % to 100 %)
11	0...255		Intensity green (0 % to 100 %)
12	0...255		Intensity blue (0 % to 100 %)
13	0...255		Main control (master dimmer, 0 % to 100 %)

7 Technical specifications

LEDs	16 × tri-3 W
Dispersion angle	30°
Number of DMX channels	5, 13
Power consumption	60 W
Operating supply voltage	100 ... 240 V ~ (AC), 50/60 Hz
Fuse	5 mm × 20 mm, 1 A, 250 V, slow
Dimensions (W × H × D)	310 mm × 72 mm × 175 mm
Weight	3 kg

8 Plug and connection assignments

Introduction

This chapter will help you select the right cables and plugs to connect your valuable equipment so that a perfect light experience is guaranteed.

Please take our tips, because especially in 'Sound & Light' caution is indicated: Even if a plug fits into a socket, the result of an incorrect connection may be a destroyed DMX controller, a short circuit or 'just' a not working light show!

DMX connections

The unit offers a 3-pin XLR socket for DMX output and a 3-pin XLR plug for DMX input. Please refer to the drawing and table below for the pin assignment of a suitable XLR plug.



Pin	Configuration
1	Ground, shielding
2	Signal inverted (DMX-, 'cold signal')
3	Signal (DMX+, 'hot signal')

9 Troubleshooting



NOTICE!

Possible data transmission errors

For error-free operation make use of dedicated DMX cables and do not use ordinary microphone cables.

Never connect the DMX input or output to audio devices such as mixers or amplifiers.

In the following we list a few common problems that may occur during operation. We give you some suggestions for easy troubleshooting:

The device does not work, no light and the fan does not work.

1. ▶ Check whether the unit is connected to mains power.
2. ▶ Check the mains power fuse.

The device is not responding to DMX controller.

1. ▶ Check the DMX connectors and cables for proper connection.
2. ▶ Check the DMX address settings and polarity.
3. ▶ Try to use another DMX controller.
4. ▶ Check to see if the DMX cables run near or even alongside to high voltage cables that may cause damage or interference to DMX interface circuitry.

If the procedures recommended above do not succeed, please contact our Service Center. You can find the contact information at www.thomann.de.

10 Cleaning

Optical lenses

Clean the optical lenses, that are accessible from the outside, regularly in order to optimize the light output. The frequency of cleaning depends on the operating environment: wet, smoky or particularly dirty surroundings can cause more accumulation of dirt on the optics of the device.

- Clean with a soft cloth using our lamp and lens cleaner (item no. 280122).
- Always dry the parts carefully.

Fan grids

The fan grids of the device must be cleaned on a regular basis to remove dust and dirt. Before cleaning, switch off the device and disconnect AC-powered devices from the mains. Use a lint-free damp cloth for cleaning. Never use solvents or alcohol for cleaning.

11 Protecting the environment

Disposal of the packaging material



For the transport and protective packaging, environmentally friendly materials have been chosen that can be supplied to normal recycling.

Ensure that plastic bags, packaging, etc. are properly disposed of.

Do not just dispose of these materials with your normal household waste, but make sure that they are collected for recycling. Please follow the notes and markings on the packaging.

Disposal of your old device



This product is subject to the European Waste Electrical and Electronic Equipment Directive (WEEE). Do not dispose with your normal household waste.

Dispose of this device through an approved waste disposal firm or through your local waste facility. When discarding the device, comply with the rules and regulations that apply in your country. If in doubt, consult your local waste disposal facility.



