

LC200 LED Lighting Controller User Manual

Revision 03

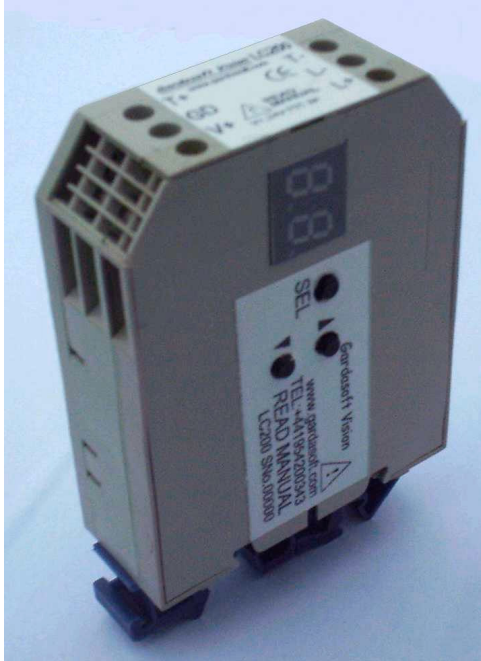

1 Disclaimer

Except as prohibited by law:

- All hardware, software and documentation is provided on an "as is" basis.
- It is essential that the user ensures that the operation of the product is suitable for their application.
- The user must ensure that incorrect functioning of this equipment cannot cause any dangerous situation or significant financial loss to occur.
- Gardasoft Vision Ltd and Gardasoft Products Ltd will not accept any liability for consequential loss of any kind.

All trademarks acknowledged. Hardware, software and documentation are Copyright 2002 – 2005 Gardasoft Products Ltd. Hardware manufactured by Gardasoft Vision Ltd under licence.

2 Safety - English

2.1.1 LC200 – Safety

Please read this before using the LC200. If in doubt, contact your distributor or Gardasoft Vision.



Where this symbol appears in the manual, refer to the text for precautions to be taken.

2.1.2 Electrical

The user must ensure that the potential difference between any combination of applied signals does not exceed the supply voltage. WARNING: Higher voltages may cause a danger to personal health.

The LC200 does not have complete tracking isolation of inputs and outputs.

Transients caused by inductive loads must be suppressed external to the LC200.

2.1.3 General

The LC200 must not be used in an application where its failure could cause a danger to personal health or damage to other equipment.

If the equipment is used in a manner not specified by the manufacturer, the protection provided by the equipment may be impaired.

3 Getting Started

Read the section on Safety.

Check "Lighting Types" to ensure that you have the correct model of LC200 for your light.

Connect your light as described in "Connections." Connect a 24V DC power supply and switch it on.

When the LC200 powers up it should automatically sense the lighting unit. The light will flash for a while and then go to 50% intensity.

Read the "Operation" section and use the buttons to vary the brightness of your lighting unit.

Mount the LC200 as described in "Mechanical Fixing" using a DIN rail.

Set up the LC200 for the continuous or pulsed operation and test as described in the "Operation" section.

If an error occurs at any time refer to the "Error Code" section.

Visit www.gardasoft.com for Application Notes on the LC200.

4 General Description

The LC200 current controller provides repeatable control of LED lighting for machine vision applications including power supply, intensity control, timing and triggering functions.

The LC200 is set up using three push buttons and a two digit seven-segment display. Configurations are saved in non-volatile memory so that the LC200 will resume operation after a power cycle.

4.1 Safe-Sense™ Technology

The LC200 provides automatic, fool-proof operation for voltage rated lighting. Select the LC200-12V or LC200-24V as appropriate for your light. The LC200 will detect the connection and disconnection of the light and on connection will automatically sense the current rating of the light.

4.2 Lighting Types

The LC200 comes in four versions:

LC200-12V	For 12V lighting
LC200-24V	For 24V lighting
LC200-350	For 350mA lighting
LC200-700	For 700mA lighting

LEDs should be driven using a constant current source, not a constant voltage. This is because small variations in temperature or voltage can cause a large change in brightness in LEDs. The brightness is approximately linear with current, so by driving the lighting with a current, intensity control is linear. Intensity control with voltage is very difficult because of the extreme non-linearity of brightness with voltage.

Traditionally, many manufacturers have rated their lighting by voltage, without giving a specification for the current required. The 12V and 24V types above are designed to support these legacy lights. When a 12V or 24V light is connected, the LC200 automatically senses the current rating of the lighting. It then drives the lighting using a constant current, allowing all the advantages of current drive for voltage rated lighting.

4.3 Output

Two modes of operation are provided:

- Continuous:**
In continuous mode the output is a continuous current.
- Pulsed:**
In this mode output is pulsed once per trigger. A digital input is used as a trigger. The delay and pulse duration can range from 100 microseconds to 1 milliseconds in 100 microsecond steps and from 1 millisecond to 99 milliseconds in 1 millisecond steps.

In continuous mode, the output current can be varied from 0% to 100% of full brightness.

In pulsed mode, the brightness can be set up to 500% of its rating, but only for short periods and at low duty cycles, so that the lighting does not overheat and get damaged. This is also limited by the maximum allowable pulse current of 2A (e.g. if a lamp takes 1A continuously, then the maximum output brightness would be 200% regardless of pulse width and duty cycle)

Output Brightness	Allowed Pulse Width	Allowed Duty Cycle
0 to 100%	99ms	100%
101% to 200%	30ms	30%
201% to 300%	10ms	20%
301% to 400%	1ms	10%
401% to 500%	0.5ms	5%

So for example, if the brightness is set to 350%, then the LC200 will not allow pulses greater than 1millisecond long. If the trigger pulses are too close together so that the lights are on for more than 10% of the time, the LC200 will stop the output and flag an error.

5 Specifications

Parameter	Value	Notes
Supply Voltage	24V DC \pm 5% regulated	
Supply Current	30mA	This figure excludes the current needed to drive the output. The current requirements may be up to 2A at maximum output.
Maximum Load Voltage	32V DC	This can be higher than the Supply Voltage.
Output Current	Up to 1.2A continuous or 2A pulsed	
Input Logic High	5V to 24V	This is the voltage applied between the +ve and -ve of the trigger input
Input Logic Low	<1 V	
Ambient Temperature During Operation	5°C to 40°C	
Maximum Relative Humidity During Operation	90%rH non-condensing	
Maximum Unit Power Dissipation	3W	

6 Mechanical Fixing

The LC200 can be fixed onto a standard 35mm DIN rail.

The LC200 does not have an IP rating and should be mounted so that moisture and dirt cannot enter the unit.

An enclosure may also be required for other parts of the system such as power supplies and will provide mechanical and environmental protection in industrial applications.

7 Connections

7.1 General

All connections are made via screw terminations on the side of the unit.

Ensure that the wire gauge used for these connections is appropriate for the current to be drawn. Ideally, wires should be secured to ensure they cannot come loose. Route low voltage and mains wiring separately. If they must be loomed together ensure that low voltage insulation rating is sufficient or that supplementary insulation is used.

7.1.1 Power Connections

The LC200 should be powered from a single +24V DC supply.

The power is connected on the V+ and GD (ground) screw terminals.

7.1.2 Signal Connections

See the Specifications Section for the electrical limits on these connections. Check all connections carefully before switching on.

Ensure that the polarity of V+ and GD is correct.

The digital trigger input is marked T+ and T-, and should be connected to a suitable +5 to +24V trigger source, or left unconnected when not used.

Connect the LED lighting to L+ and L-.

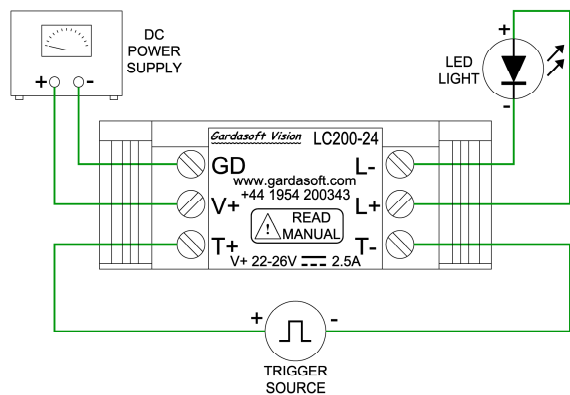

8 Operation

The LC200 is set up using the push buttons and display on the front of the unit. The set up is non-volatile, so the LC200 will resume the same operation after a power cycle if a light is connected.

The overall operation is given below.

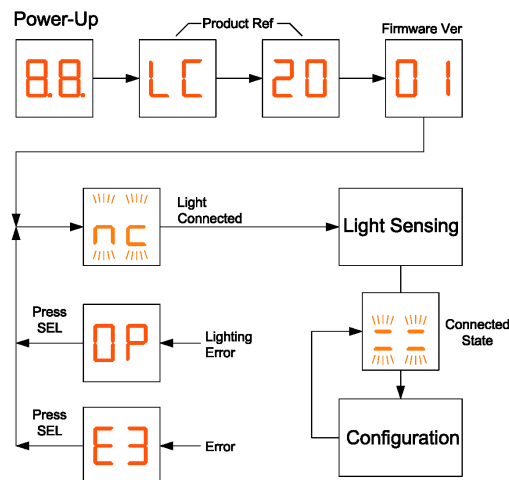

8.1 Power Up

On power up, the LC200 will display "8.8." to test the display is working, then "LC", "20", followed by the version number, eg "01", and then will be ready for operation. To show that the unit is operating normally, an alternating pattern is drawn on the display.

The unit will initially show "nc" on the display until a light is connected.

8.2 Cold Start

In the unlikely event that the non-volatile memory becomes corrupt the LC200 may not start up properly. In this case the memory can be cleared by powering up the LC200 while holding down the SELECT and DOWN buttons. The LC200 will display "CL" for about 5 seconds while the memory is cleared.

8.3 Current Sensing

When no light is connected, the LC200 displays "nc" and continually checks for a light being connected. When it detects a light, it will display "SN".

For the LC200-350 and LC200-700 the controller knows what the current rating of the light is so no further sensing is required.

For the LC200-12V and LC200-24V, the controller will automatically sense the current rating of the light by increasing the output current until the voltage rating is reached.

Once the LC200 has detected the light and is ready to operate, two alternating bars are shown on the display. By default the output is set to continuous at 50% of full brightness.

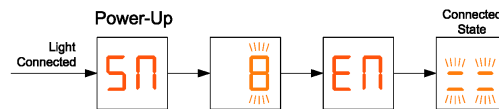

8.4 Connected State

Once the LC200 has detected that a light is connected and the current rating has been determined, the user can then set up the LC200 for Continuous or Pulsed output.

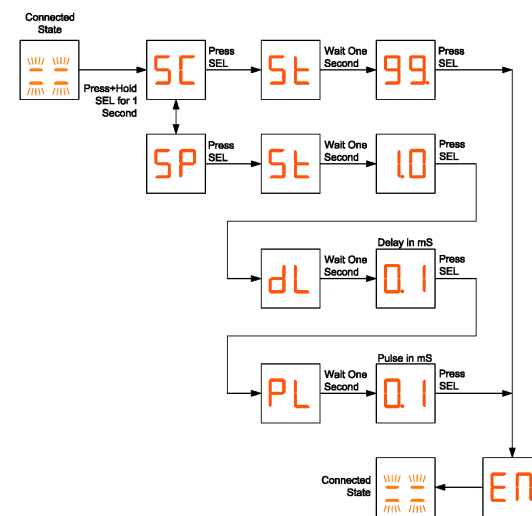

8.4.1 Continuous Output

To set up continuous mode:

- Press and hold the SEL button for one second
- Select "SC" using the up and down buttons
- Press SEL
- Set the brightness from 0 to 99 (percent)
- Press SEL.

As the brightness setting is changed the brightness of the light will also change.

8.4.2 Pulsed Output

When pulsing the lighting, three parameters are available:

- Brightness
- Delay from trigger to pulse
- Length of pulse

The brightness can be adjusted from 0.1 (10%) to 5.0 (500%) of the continuous brightness. There are limitations between the set brightness level, and the maximum allowed pulse length/duty cycle, refer to the General Description for details.

To set up pulse mode:

- Press and hold the SEL button for one second
- Select "SP" using the up and down buttons
- Press SEL
- Set the brightness from 0.0 to 5.0
- Press SEL
- Set the pulse delay from 0.1 to 99 milliseconds
- Press SEL
- Set the pulse width from 0.1 to 99 milliseconds
- Press SEL

When the user is setting up the pulse delay and pulse width, the display will show "0.1" to "0.9" for periods less than 1

millisecond and the time is adjustable in 0.1 millisecond steps. From 1 millisecond upwards, the display will show "1." to "99." and the time will be adjustable in 1 millisecond steps.

Note, if at any time a mistake is made, it will be necessary to go through the menu again.

Triggers occur on the leading edge of the trigger input, that is on the transition from 0V to (for example) 5V input.

When setting up lighting, the user can press the DOWN button on the LC200 to simulate a trigger and generate an output pulse.

When a trigger is received, the display shows "PL" briefly to show that the light is being pulsed.

9 Error Codes

The following error messages are displayed on the LC200 display.

Error	Reason
E1	While sensing the current rating, the output became open circuit
E2	While sensing the current rating, the required voltage could not be reached
E3	While sensing the current rating, the output current was incorrect
EC	Over driving protection in pulse mode. The pulse trigger rate is too high.
ET	Thermal cutout. Internal temperature is too high.
SH	Output connection is short circuit
OP	Output connection is open circuit
PO	Internal power protection cut out

Gardasoft LED Lighting Controllers

The following products are available at the time of writing. New products will be introduced. See www.gardasoft.com for details of the current range.

LC200 Range

- 1 output channel up to 2A
- Models for voltage and current rated lights
- 1 digital input
- SafeSense™ Technology

PP600 Range

- 2 output channels up to 10A each
- 2 digital inputs

- PP600 Lighting controller
- PP610 Lighting controller with RS232

- PP701 DIN Rail mounting clip for PP600 and PP600F range

PP600F Range

- Same as the PP600 range but with fast pulsing
- Pulse delay from 10us to 9.9ms in 1us steps
- Pulse width from 1us to 9.9ms in 1us steps

- PP600F Lighting controller
- PP610F Lighting controller with RS232

PP860, PP861

- High current, high accuracy controller
- 8 output channels up to 20A each
- Pulses accurate to 0.1 microseconds
- RS232 configuration