

■ CLAMP-ON HARMONIC METER

721

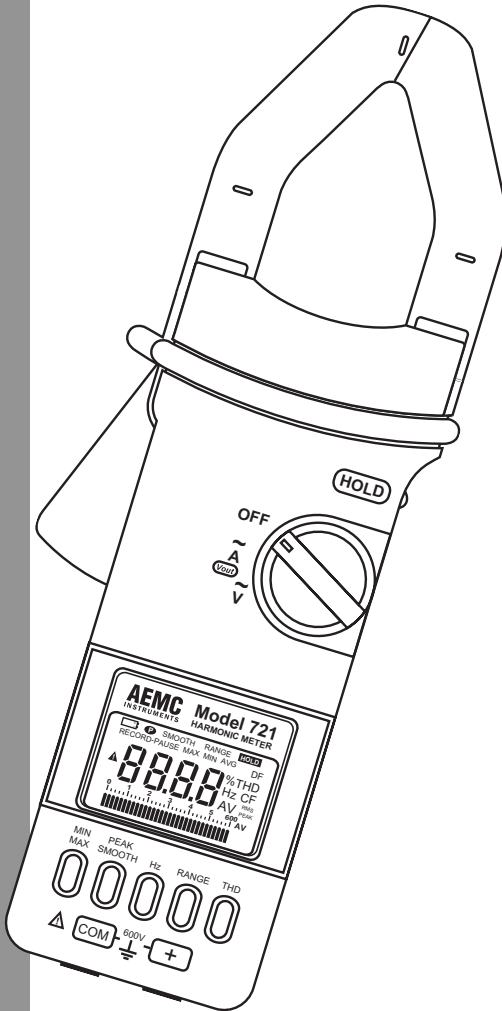

TABLE OF CONTENTS

1. INTRODUCTION	3
1.1 Receiving Your Shipment.....	4
1.2 Ordering Information.....	4
2. PRODUCT FEATURES	5
2.1 Description.....	5
2.2 Control Features.....	7
2.3 Digital Display Features.....	8
2.3.1 Display and Error Indications.....	9
3. SPECIFICATIONS	10
3.1 Electrical Specifications.....	10
3.2 General Specifications.....	12
3.3 Mechanical Specifications.....	12
3.4 Safety Specifications.....	13
4. UNDERSTANDING ELECTRICAL HARMONICS	14
4.1 Detection and Measurement.....	20
4.2 Effects on the System.....	21
4.3 Transformer Derating.....	22
4.4 Meter Readings.....	23
4.5 Crest Factor.....	23
4.6 Limiting the Effects of Harmonics.....	24
5. OPERATION	25
5.1 Current Measurements.....	25
5.1.1 Ranging.....	26
5.1.2 Analog Output – Vout.....	26
5.1.3 Other Functions.....	26
5.1.4 Bargraph.....	26
5.2 Voltage Measurements.....	27
5.2.1 Ranging.....	28
5.2.2 Other Functions.....	28
5.2.3 Bargraph.....	28

5.3	THD Push Button: Power Quality Measurements.....	29
5.3.1	%THD: Total Harmonic Distortion	29
5.3.2	%DF: Distortion Factor	31
5.3.3	CF: Crest Factor	32
5.3.4	Bargraph	32
5.4	Range Push Button: Manual Ranges	33
5.5	Hz Push Button: Frequency Measurement.....	34
5.6	Peak/Smooth Push Button.....	35
5.6.1	Smooth	35
5.6.2	Peak.....	36
5.7	MIN/MAX Push Button: Recording Function.....	36
5.8	Vout – Analog Output.....	38
5.8.1	Output Level	39
5.9	Summary of Accessible Functions.....	39
5.10	Auto-Off Feature	40
5.11	Troubleshooting	40
6.	MAINTENANCE	41
6.1	Cleaning.....	41
6.2	Battery Test & Replacement	41
6.2.1	Battery Replacement	42
	Repair and Calibration.....	43
	Technical and Sales Assistance	43
	Limited Warranty	44
	Warranty Repairs.....	44

CHAPTER 1

INTRODUCTION



These safety warnings are provided to ensure the safety of personnel and proper operation of the instrument.

- Read this instruction manual completely before attempting to use or service this instrument and follow all the safety information.
- Use caution on any circuit: Potentially high voltages and currents may be present and may pose a shock hazard.
- The meter must not be operated beyond its specified operating range.
- Safety is the responsibility of the operator.
- Never open the back of the meter while connected to any circuit or input.
- Always make connections **from** the instrument **to** the circuit under test.
- Always inspect the instrument and accessory leads for serviceability prior to use, and replace defective parts immediately.
- Do not use the meter or any test leads, BNC leads, connectors, probes or clips if they look damaged.
- Never use the meter on electrical conductors rated above 600Vrms.

International Electrical Symbols



This symbol signifies that the instrument is protected by double or reinforced insulation. Use only specified replacement parts when servicing the instrument.



This symbol on the instrument indicates a WARNING and that the operator must refer to the user manual for instructions before operating the instrument. In this manual, the symbol preceding instructions indicates that if the instructions are not followed, bodily injury, installation/sample and product damage may result.



Risk of electric shock. The voltage at the parts marked with this symbol may be dangerous.

1.1 Receiving Your Shipment

Upon receiving your shipment, make sure that the contents are consistent with the packing list. Notify your distributor of any missing items. If the equipment appears to be damaged, file a claim immediately with the carrier and notify your distributor at once, giving a detailed description of any damage. Save the damaged packing container to substantiate your claim.

1.2 Ordering Information

Harmonic Meter Model 721 Cat. #1208.52

Includes a 9V battery, two 5 ft (1.5m) leads, two test probes, two grip probes, one insulated banana to BNC connector, a user manual and a hard carrying case.

PRODUCT FEATURES

2.1 Description

The Harmonic Meter Model 721 combines the simplicity and familiarity of digital clamp-ons with today's critical information on power quality and harmonics.

Operation is simple and direct, with no menus, calculations or complex analyzer procedures. Select Amps or Volts on the rotary dial, connect, and measure. The push of a button gives additional or more specific information. You can troubleshoot and measure power quality with the ease of using a digital clamp-on — simply, safely, and economically.

The Model 721 performs current and voltage measurements in True RMS, and provides immediate readings of total harmonic distortion (%THD), distortion factor (%DF), crest factor (CF) and Peak of distorted currents and complex voltages. It also gives the minimum, maximum, maximum Peak and average measurement values so you can record for over 24 hours to monitor daily fluctuations. And, you can measure frequency (Hz) through either the current or the voltage at any time.

In addition, the instrument's analog output allows display of the current waveforms on any oscilloscope or hand-held scope while measuring; or the output may be used for loggers and recorders.

The Model 721 incorporates True RMS electronics and measurement techniques to ensure correct and accurate readings on distorted waveforms. Use the Model 721 as a comprehensive tool for troubleshooting as well as for daily measurements on circuits supplying traditional and today's nonlinear loads.

Beyond the absolute product ruggedness and overall design qualities —the Model 721 is built with GE Lexan® and meets specific physical standards — the instrument features a high level of safety. The Model 721 meets IEC 1010-1 Category III for 600 V ratings.

The Model 721 is comfortable to hold, compact and easy to maneuver in crowded breaker panels. The hooked jaw design facilitates clamping and accommodates two 500 MCM conductors.

The AEMC Harmonic Meter Model 721 works as easily as a clamp-on multimeter, while permitting True RMS voltage and current measurements. The rotary switch selects the volt or ampere range and, beneath the large LCD, five push buttons provide direct access to additional key measurement and power quality values.

The Model 721 high sensitivity accepts low input levels (300 mA and 300 mV) permitting power quality measurements on even low power or idling equipment — an advantage not common to many instruments.

2.2 Control Features

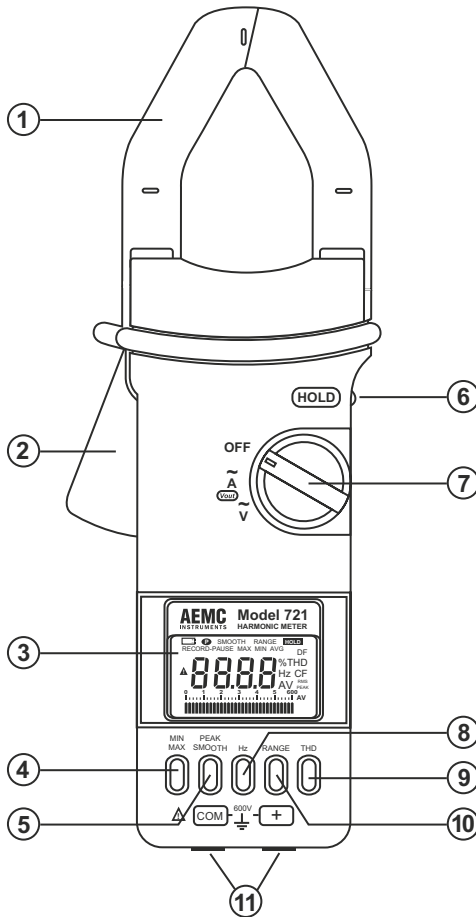

1. Jaw assembly

Transformer jaws opens to 1.7" (43 mm)
Accepts two 500 MCM

2. Lever/Trigger

Opens or closes jaws

3. Display

Liquid crystal display, 9999 count

4. Min/Max

Selects Record mode for A, V, %THD, %DF, CF, Hz
Accesses the following values: Max, Min, AVG

5. Peak/Smooth

Accesses the following modes:

- Smooth for 3-second averaging for easy readings on fluctuating signals.
- Peak measurement values (1 ms) for A and V

6. Hold/Data Hold

- Freezes last measured value on display
- Does not freeze bargraph or analog output

7. Rotary selection switch

OFF, Amps/Vout, Volts

8. Hz

Selects frequency measurement (A or V input)

9. THD

Accesses (in A or V) the following measurement modes:

- %THD (Total Harmonic Distortion referenced to the fundamental)
- %DF (Distortion Factor: THD referenced to RMS)
- CF (Crest Factor)

10. Range

Selects Auto Ranging or Manual Ranging measurement ranges (A or V)

11. Voltage Jacks and Analog Output Vout

“COM” : black

“+” : red

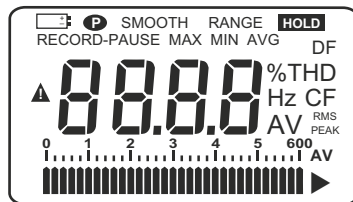

2.3 Digital Display Features



The combination digital/analog display gives measurements on a large 9999 count (3¾ digit) LCD display. A fast responding analog bargraph display provides indications for trends or surges.

A Displayed when instrument is measuring TRMS amperes

V Displayed when instrument is measuring TRMS voltage

	Indicates that internal battery requires replacement
SMOOTH	Indicates three second measurement averaging to smooth fluctuating signals
RANGE	Displayed during manual range selection
HOLD	Displayed when Hold function is activated
RECORD	Blinks (1/second) during record mode
PAUSE	Interrupts recording mode when Hold is activated in the Record Mode
MAX	Displays maximum measurement value
MIN	Displays minimum measurement value
AVG	Displays average measurement value
%THD	% Total Harmonic Distortion
%DF	% Distortion Factor
CF	Crest Factor
PEAK	Peak (1 ms) measurement (MAX Peak is available in the recording mode)
	Auto-Off feature disabled
Bargraph	Analog bargraph for trend measurements A or V and remaining battery life at power-up

2.3.1 Display and Error Indications

OL-- Input overload: > 999.9 V peak or > 999.9 A peak

--- Input signal below measurement range



Input exceeds safety, measurement or operating range. The warning triangle is accompanied by a beeping alarm. Discontinue measurement and refer to the specific function and specification section in user manual.

Please note that the warning triangle will also be displayed if the input signals are too low, or if the fundamental signal is not 50 or 60Hz.

CHAPTER 3

SPECIFICATIONS

3.1 Electrical Specifications

Reference Conditions: Accuracies are provided under the following reference conditions: Temperature 23°C ± 5K, 45% to 75% RH; battery voltage 8.5V to 9V; conductor centered in the probe jaws; DC magnetic field: earth's field; no external AC magnetic field; no external electrical field; sine wave 45 to 65 Hz. In Peak, basic accuracy is based on 1 ms samples and on a signal from 10 to 500 Hz. In THD and DF, the basic accuracy is provided for a square wave and a triangular wave with 50% duty cycle at 50 or 60 Hz. R refers to Reading and ct(s) to count(s). Counts may also be referred to as the least significant digits (LSD).

CURRENT (TRMS)

Input Range: 0.05 to 700.0 Arms (±999.9 A Peak)

Basic Accuracy: 0.3 to 99.99 A: 2% R ± 20 cts

100.0 to 400.0 A: 2% R

400.0 to 700.0 A: 5% R

Crest Factor: >3.0 below 300 A

Frequency Range: 15 Hz to 10 kHz

CURRENT (PEAK)

Input Range: 0.05 to ± 999.9 A Peak

Basic Accuracy: 0.05 to 99.99 A: 3% R ± 30 cts

100 to 600 A: 3% R

600 to 999.9 A: 8% R

VOLTAGE (TRMS)

Input Range:

0.05 to 600 Vrms (± 1200 V Peak)

Basic Accuracy: 0.3 to 400.0 V: 1.5% R ± 4 cts

400.0 to 999.9 V: 1.5% R

Crest Factor: >4.0 below 300 V

Input Impedance: 1 MΩ, 47 pF

Frequency Range: 15 Hz to 10 kHz

VOLTAGE (PEAK)

Input Range: 0.05 to 999.9 V Peak

Basic Accuracy: 0.05 to 99.99 V: 3% R \pm 30 cts
100 to 999.9 V: 3% R

TOTAL HARMONIC DISTORTION (%THD)

Range: 0.5% to 600.0%

Resolution: 0.1%

Minimum Input: 300 mA, 300 mV

Basic Accuracy (50/60 Hz): 3% \pm 2 cts

Frequency Range: Fundamental 45 to 65 Hz, 25th harmonic

Display: Digital - %THD; Bargraph - True RMS (A or V)

DISTORTION FACTOR (%DF)

Range: 0.5% to 100%

Resolution: 0.1%

Minimum Input: 300 mA, 300 mV

Basic Accuracy (50/60 Hz): 3% R \pm 2 cts

Frequency Range: Fundamental 45 to 65 Hz, 25th harmonic

Display: Digital - %DF; Bargraph - True RMS (A or V)

CREST FACTOR (CF)

Range: 1.00 to 10.00

Resolution: 0.01

Minimum Input: 300 mA, 300 mV

Accuracy (40 to 450 Hz): 10% \pm 3 cts

Frequency Range: 15 Hz to 10 kHz

Display: Digital - CF; Bargraph - True RMS (A or V)

FREQUENCY (Hz)

Range: 0.5 to 9999 Hz

Minimum Input: 1 A or 1 V

Accuracy: 0.5 Hz to 999.9 Hz: 0.1% R \pm 1 ct
1000 Hz to 9999 Hz: 0.2% R \pm 1 ct

Display: Digital - Hz; Bargraph - True RMS (A or V)

ANALOG OUTPUT (Vout)

Range: 1 mV/A (0.05 to 700 Arms) or,
10 mV/A (0.05 to 60 Arms)

Basic Accuracy: 3%

Input: 0.05 A to 999.9 A Peak

Output Impedance: 4 k Ω , 47 pF

Display: Digital - all A and THD functions; Bargraph - Arms

3.2 General Specifications

Power Source: 9 V Alkaline battery (NEDA 1604, 6LF22, 6LR61)

Power Source Life: 50 hr continuous use approx

Dimensions: 10 x 3.8 x 1.7" (254 x 97 x 44 mm)

Weight: 1.3 lb (600 g)

Display: Quadriplexed LCD with 12.5 mm digits; 3¾ digits, 9999cts

Temperature:

Operating: +14° to 131°F (-10° to +55°C)

Storage: -40° to 158°F (-40° to +70°C)

Humidity:

Operating: 0 to 80% RH to +40°C (50% RH @ +55°C)

Storage: 0 to 95% RH

Material:

Case: Gray Lexan® 920A, UL 94 V2

Jaws: Red Lexan® 500R, 10% fiberglass, UL 94 V0

LCD lens: Crystal Lexan® 920A, UL 94 V1

Altitude:

Operating: 2000 m (6500 ft)

Storage: 5000 m (16,000 ft)

3.3 Mechanical Specifications

Envelope Protection: IEC 529: IP 40

Drop Test: IEC 68-2-32: 1m

Vibration: IEC 68-2-6

Shocks: IEC 68-2-27

3.4 Safety Specifications

Protection Level:

Double insulation; IEC 1010-1, 600 V Category III, Pollution degree 2.

Working Voltage: 600 Vrms

Dielectric Test: 5.5 kV, 50/60 Hz, 1 minute

Overload Protection:

Voltage: 1.5 kV Peak permanent

Current: 3000 A AC permanent

Analog output: 1.5 kV Peak permanent

Agency Approvals: UL[®], CSA, GS, VDE

ELECTROMAGNETIC COMPATIBILITY

Electrostatic Discharge:

IEC 801-2: No influence: 4 kV class 2

Non-destructive: 15 kV class 4

RF:

IEC 801-3: No influence: 3 V/m class 2

Minor influence: 10 V/m class 3

Transients: IEC 801-4: No influence: 2 kV class 4

Electric shocks: IEC 801-5: No influence: 1 kV class 3

UNDERSTANDING ELECTRICAL HARMONICS

Until fairly recently, power quality referred to the ability of the electric utilities to supply electric power without interruption. Today, the phrase encompasses any deviation from a perfect sinusoidal waveform. Power quality now relates to short-term transients as well as steady state distortions. Power system harmonics are a steady state problem with dangerous results. Harmonics can be present in current, voltage, or both. Within the next few years, as many as half of all electrical devices will operate with nonlinear current draw.

Utility companies invest millions of dollars each year to ensure that voltage supplied to their customers is as close as possible to a sinusoidal waveform. If the power user connects loads to the system which are resistive, such as an incandescent light bulb, the resulting current waveform will also be sinusoidal. However, if the loads are nonlinear, which is typically the case, the current is drawn in short pulses and the current waveform will be distorted. Total current that is then drawn by the nonlinear load would be the fundamental as well as all the harmonics.

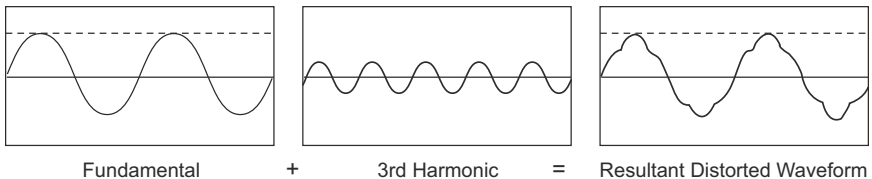

Harmonic distortion can cause serious problems for the users of electric power, from inadvertent tripping of circuit breakers to dangerous overheating of transformers and neutral conductors, as well as heating in motors and capacitor failure. Harmonics can cause problems that are easy to recognize but difficult to diagnose.

It is becoming increasingly important to understand the fundamentals of harmonics, and to be able to recognize and monitor the presence of damaging harmonics. Harmonics within an electrical system vary greatly within different parts of the same distribution system and are not limited simply

to the supply of the harmonic-producing device. Harmonics can interact within the system through direct system connections or even through capacitive or inductive coupling.

A harmonic may be defined as an integer multiple of a fundamental frequency. Harmonics are designated by their harmonic number. For our discussion, we will focus on the 60 Hz power frequency. The second harmonic would be two times the fundamental or 120 Hz. The third would be three times the fundamental or 180 Hz, and so on.

Nonlinear equipment generates harmonic frequencies. The nonlinear nature of a device draws current waveforms that do not follow the voltage waveform. Electronic equipment is a good example. While this is a broad category that encompasses many different types of equipment, most of these devices have one characteristic in common: They rely on an internal DC power source for their operation.

LOADS WHICH PRODUCE HARMONIC CURRENTS:

- Electronic lighting ballast
- Electric arc furnaces
- Electric welding equipment
- Industrial process controls
- Saturated transformers
- Medical equipment
- Adjustable speed drives
- Personal computers
- Solid state rectifiers
- UPS systems
- Solid state elevator controls

This is by no means an exhaustive list of equipment which generate harmonics. Any electronic-based equipment should be suspected of producing harmonics.

Due to the ever increasing use of electronics, the percentage of equipment which generates harmonic current has increased significantly. The harmonic problem manifests itself with proliferation of equipment using diode-capacitor input power supplies. This type of equipment draws current in a short pulse only during the Peak of the sine wave. The result of this action, aside from improved efficiency, is that high frequency harmonics are superimposed onto the fundamental 60 Hz frequency.

The harmonics are produced by the diode-capacitor input section which rectifies the AC signal into DC. The circuit draws current from the line only during the peaks of the voltage waveform, thereby charging a capacitor to the Peak of line voltage. The equipment DC requirements are fed from this capacitor and as a result the current waveform becomes distorted.

Harmonics in the electric power system combine with the fundamental frequency to create distortion. The level of distortion is directly related to the frequencies and amplitudes of the harmonic current. The contribution of all harmonic frequency currents to the fundamental current is known as “Total Harmonic Distortion” or THD. This THD value is expressed as a percentage of the fundamental current. THD values of over 10% are reason for concern.

THD is calculated as the square root of the sum of the squares of all the harmonics divided by the fundamental signal (50 or 60 Hz). This calculation arrives at the value of distortion as a percentage of the fundamental.

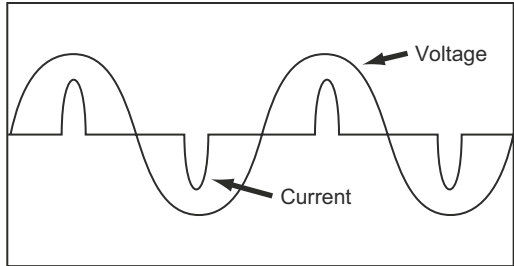

Nonlinear Current Draw

Mathematically, %THD is the ratio of the root-mean-square (RMS) of the harmonic content to the root-mean-square (RMS) value of the fundamental 50 or 60 Hz signal. THD is expressed as a percentage, and may be greater than 100%.

Total Harmonic Distortion

$$\%THD = \sqrt{\left(\frac{\text{Sum of squares of amplitudes of all harmonics}}{\text{Square of amplitude of fundamental}} \right)} * 100$$

$$\%THD \text{ (current)} = \sqrt{[(I_2)^2+(I_3)^2+(I_4)^2+(I_5)^2.. / (I_1)^2]} * 100$$

$$\%THD \text{ (voltage)} = \sqrt{[(V_2)^2+(V_3)^2+(V_4)^2+(V_5)^2.. / (V_1)^2]} * 100$$

Wherever there are large numbers of nonlinear loads, there are sure to be harmonics in the distribution system. Harmonic-producing equipment is found in varied locations from administrative offices to manufacturing facilities. In the factory environment, electronic power converters such as variable speed drives, SCR drives, etc., are the largest contributors to harmonic distortion. It is not uncommon to have THD levels as high as 25% within some industrial settings.

Most single-phase office equipment draws nonlinear current. While fluorescent lighting with electronic ballasts and many types of office equipment contribute to creating harmonics, personal computer power supplies are the largest contributor of harmonics within the office environment. Although THD levels will be lower than in an industrial setting, the susceptibility of office equipment to variations in power quality is extremely high.

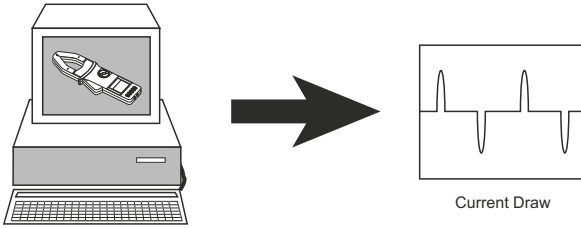

Computer Current Waveform

In the industrial environment, there can be many three-phase, nonlinear loads drawing high levels of load current. The most prevalent harmonic frequencies are the odd integer multiples of the 60 Hz frequency. The third harmonic (180 Hz) is always the most prevalent and troublesome.

In general, even harmonics cancel out and are negligible. The largest single current draw for ballasts is the third harmonic. Triplens (odd multiples of the third harmonic) are typically the dominant harmonics and are most common in single-phase, nonlinear loads. The fifth and seventh harmonics are dominant generally in motor drives.

Large commercial buildings have many different sizes and types of loads. In most installations the power is distributed with 208/120 volt transformers in a Delta-Wye configuration. When multiple loads are supplied, each generates triplen harmonic currents on the neutral conductor which are sent on to the transformer secondary and reflected into the delta primary. These currents circulate within the delta primary causing overheating and shortened service life.

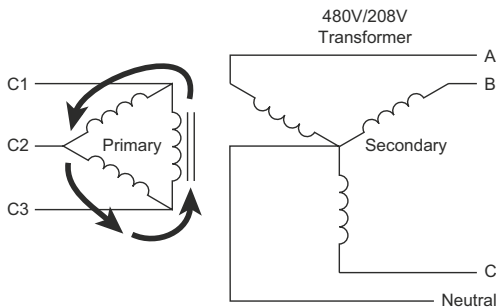

Delta Primary, Circulating Current

Harmonics can cause a variety of problems to any electrical power user. For large users, the problems can be intense. For electronic equipment that relies on the zero crossing of the sinusoidal waveform, such as clock timing devices, heavy harmonic content can cause a zero crossing point offset.

Odd number harmonics (3rd, 5th, & 7th) cause the greatest concern in the electrical distribution system. Because the harmonic waveform usually swings equally in both the positive and negative direction, the even number harmonics are mitigated.

Heating effect causes the greatest problem in electrical equipment. Many times, electrical distribution equipment has overheated and failed even when operating well below the suggested rating requirements. Temperature increase is directly related to the increase in RMS current.

Because harmonic frequencies are always higher than the 60 Hz fundamental frequency, "skin effect" also becomes a factor. Skin effect is a phenomenon where the higher frequency causes the electrons to flow toward the outer sides of the conductor, effectively reducing the cross-sectional diameter of the conductor and thereby reducing the ampacity rating of the cable. This effect increases as the frequency and the amplitude increase. As a result, higher harmonic frequencies cause a greater degree of heating in conductors.

On balanced three-phase systems with no harmonic content, the line currents are 120 degrees out-of-phase, canceling each other and resulting in very little neutral current. However, when there is distortion in any one of the phase currents, the harmonic currents increase and the cancellation effect is lessened. The result is typically a neutral current that is significantly higher than planned. The triplen harmonics (odd multiples of three) are additive in the neutral and can quickly cause dangerous overheating.

In theory, the maximum current that the neutral will carry is 1.73 times the phase current. If not sized correctly, overheating will result. Higher than normal neutral current will cause voltage drops between neutral and ground which are well above normal. Readings above 4 volts indicate high neutral current.

False tripping of circuit breakers is also a problem encountered with the higher frequencies that harmonics produce. Peak sensing circuit breakers often will trip even though the amperage value has not been exceeded. Harmonic current Peak values can be many times higher than sinusoidal waveforms.

Power factor correction capacitor failure in many cases can be directly attributed to harmonic content. Capacitors appear as extremely low impedance values and are more susceptible to harmonics. Inductive reactance varies directly with frequency ($X_L=2\pi fL$). Parallel resonance between the capacitor bank and the source impedance can cause system resonance resulting in higher than normal currents and voltages. High harmonic currents have been known to overheat correction capacitors, causing premature failure and sometimes resulting in explosion.

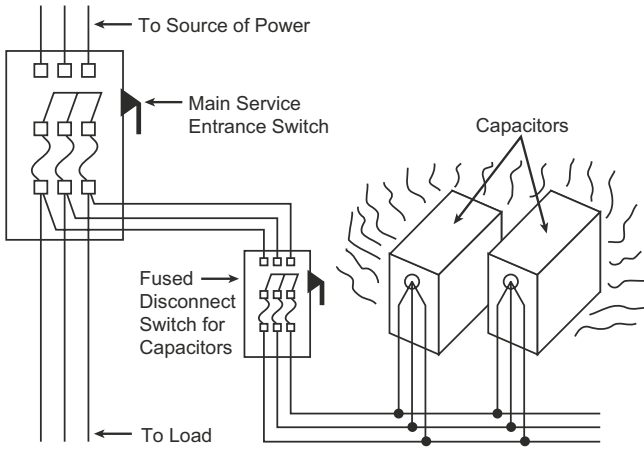

Power Factor Capacitors at Resonant Frequency

Most harmonic problems result when the resonant frequency is close to the 5th or 7th harmonic. These happen to be the largest harmonic amplitude numbers that adjustable speed drives create. When this situation arises, capacitor banks should be resized to shift the resonant point to another frequency.

Another useful parameter is the Distortion Factor, or %DF. %DF is the Total Harmonic Distortion referenced to the total RMS signal.

The Distortion Factor is expressed as a percentage, and may not be greater than 100%. We provide this term because of the market need and the requirement of this value under the international standard IEC-555.

Mathematically, %DF is the ratio of the root-mean-square(RMS) of the harmonic content to the root-mean-square (RMS) value of the total signal, and expressed as a percentage.

Distortion Factor

$$\%DF = \sqrt{\left(\frac{\text{Sum of squares of amplitudes of all harmonics}}{\text{Total RMS}} \right)} * 100$$

$$\%DF \text{ (current)} = \sqrt{[(I_2)^2 + (I_3)^2 + (I_4)^2 + (I_5)^2 \dots / (I_{RMS})^2]} * 100$$

$$\%DF \text{ (voltage)} = \sqrt{[(V_2)^2 + (V_3)^2 + (V_4)^2 + (V_5)^2 \dots / (V_{RMS})^2]} * 100$$

Please note that our %DF is not the same value as the Distortion Factor as expressed in the IEEE standard 519-1992 (in which Distortion Factor is same as THD).

4.1 Detection and Measurement

Harmonic analysis is the first step in alleviating the many problems that can be encountered. Field measurements are performed to identify frequency and magnitude. An important factor to remember is that most distribution systems are designed specifically to carry 60 Hz. To begin identifying a possible harmonics problem, take an inventory of equipment that may generate harmonic currents (e.g. electronic equipment, fluorescent lighting fixtures with electronic ballasts, variable speed motors, etc).

List the nonlinear loads which are on each branch circuit. The electrical panel is the point at which most nonlinear harmonic problems can be detected. Excessive current flow on the neutral can be detected with a True RMS current meter, but may also be indicated by a resonant buzzing sound or even visually with discolored connections on the neutral buss.

Beginning at the service entrance panel, measure and record the True RMS current in each phase, as well as the neutral of the distribution transformer secondary. Compare this measured neutral current to the anticipated current due to phase imbalance. If the phase currents are equal, the vector sum of the neutral currents will add to zero. If excessive amounts of triplen harmonics are present in the neutral, neutral current may exceed phase current. Consult the NEC® for the maximum ampacity for each of the conductors that have been tested.

Measure each feeder for harmonic content. A high degree at this location is often heard as a buzzing sound. A voltage THD reading is also useful at this location.

IEEE standard 519-1992 is a guidance document for utilities and electric power users which specifies both the maximum distortion levels and recommended correction levels. The harmonic distortion limit of 5% is proven to be the point where harmonics begin to have a detrimental effect on an electrical distribution system.

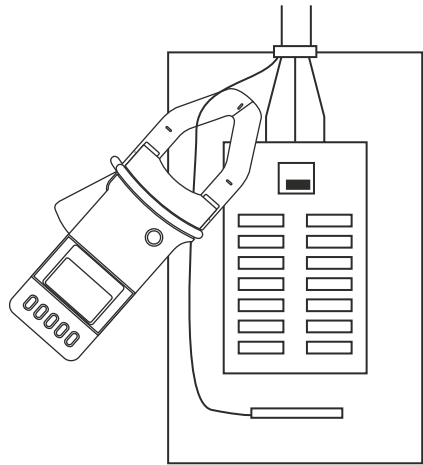

Measuring Neutral Currents at Service Entrance Panel

Harmonic current measurements define the harmonic generating characteristics of the load, so measurements should be taken at the load when possible. Voltage measurements define the system response and are usually taken at the individual busses.

4.2 Effects on the System

To compound the problems that harmonic currents present to the system, the nonlinear harmonic load currents also have an Ohm's Law relationship with the source impedance of the system to produce voltage harmonics. Consider a heavily loaded transformer that is affected by one branch circuit feeding a nonlinear load; the resulting voltage harmonics can then be passed down to all the remaining circuits fed by that transformer.

Voltage harmonics may cause havoc within the electrical system. Motors are typically considered to be linear loads; however, when the source voltage supply is rich in harmonics, the motor will draw harmonic current. The result is typically a higher than normal operating temperature and shortened service life.

Different frequency harmonic currents can cause additional rotating fields in the motor. Depending on the frequency, the motor will rotate in the opposite direction (counter-torque). The fifth harmonic, which is very prevalent, is a negative sequence harmonic causing the motor to have a backward rotation, shortening the service life.

Noise can be picked up in communication equipment and telephone systems when harmonics at audio or radio frequencies are inductively or capacitively coupled into communication or data lines.

When induction-disc watt-hour meters are monitoring nonlinear loads, depending on the content of the harmonics, the disk may run slower or faster, resulting in erroneous readings.

4.3 Transformer Derating

Most generators and transformers base their operating characteristics on non disturbed 60 Hz waveforms. When the waveforms are rich in harmonics, shortened service or complete failure is sure to follow.

The derating K factor can be applied specifically to transformers to ensure that dangerous heating will not result due to the transformer supplying load currents which are rich in harmonic content.

The K factor is determined by measuring the True RMS current of each harmonic, multiplied by the harmonic order and squared. The total sum of this is then multiplied by the eddy current losses. Transformer parasitic heating due to harmonic currents is frequency-dependent; higher frequency harmonic currents cause a higher degree of transformer heating and failure.

The K factor can be thought of as an index of the transformer's ability to handle nonlinear load current without abnormal heating. Some distribution transformers today are being designed with magnetic cores and windings to accommodate harmonic contents.

A K-rated transformer is specifically designed to handle nonlinear loads. The higher the K factor value, the better the ability of the transformer to handle nonlinear loads.

IEEE C57.110-1986 is a prescribed procedure used to derate the transformer loading based on the specific harmonic content. Each specific electrical application is unique in type and amount of harmonic interaction.

IEEE C57.12.00-1987 has proposed a limit of 5% for transformer harmonic current factor.

An alternate method for derating transformers is available for buildings which supply single-phase, 120 V receptacles. This method is established by The Computer & Business Equipment Manufacturers Association (CBEMA).

$$\text{CBEMA Derating Factor} = \frac{1.414}{\text{Crest Factor}}$$

4.4 Meter Readings

Harmonic problems can be analyzed more easily with the proper test equipment.

The term “True RMS”, or Root-Mean-Square, relates to the equivalent DC heating value of the current or voltage waveform. If, for example, we apply a pure sine wave and a distorted sine wave to a resistive load, the point where they both create the same heating value is the point where they both have the same RMS value.

True RMS capability is required to accurately measure systems where harmonic current is present. Average responding instruments will yield erroneous measurement results from 25-40% below the actual value when harmonic distortion is present.

Many instruments on the market measure average or Peak values of a waveform and internally multiply by 1.11 or .707 respectively to indicate RMS values. These devices work well when measuring a pure sine wave.

Instruments with True RMS converters sample the waveform at many different points and provide accurate readings on distorted waveforms. Microprocessor-based circuits sample, digitize and square each sample, add it to the previous sample squared and take the square root of the total. This process will yield a True RMS value regardless of the amount of distortion.

4.5 Crest Factor

The crest factor is the ratio of the Peak value of the sinusoidal waveform to its RMS value.

$$\text{Crest Factor (CF)} = \frac{\text{Peak Value}}{\text{RMS value}}$$

Crest factor indicates the level of peaking that an instrument can handle without errors in the measurement. For a perfect sine wave the crest factor would be 1.414. This relates to the Peak amplitude that an instrument is capable of measuring accurately. Typical crest factor ratings are from 2.0 to 6.0. The higher the factor, the more capable the instrument of measuring a complex waveform correctly. When harmonics are present crest factors may be less than (CF of a square wave = 1) or greater than 1.414.

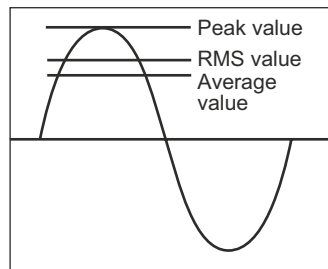

**RMS - Avg - Peak
Relationship on Sine Wave**

4.6 Limiting the Effects of Harmonics

Derating certain types of electrical equipment is the easiest way to limit the effects that the increased heating has on the equipment. A 25% derating for transformers and generators is commonly employed in industry.

Filtering is currently the most common method used to limit the effects that harmonics present to the rest of the system. Filters typically consist of tuned series L-C circuits. Filter impedance is negligible with respect to the rest of the system, limiting its interaction effects for harmonic control. Filters are sized to withstand the RMS current as well as the value of current for the harmonics.

In the future, systems may be available which will offset harmonics by applying signals that are equal in amplitude but opposite in phase, thereby canceling or severely limiting harmonic effects.

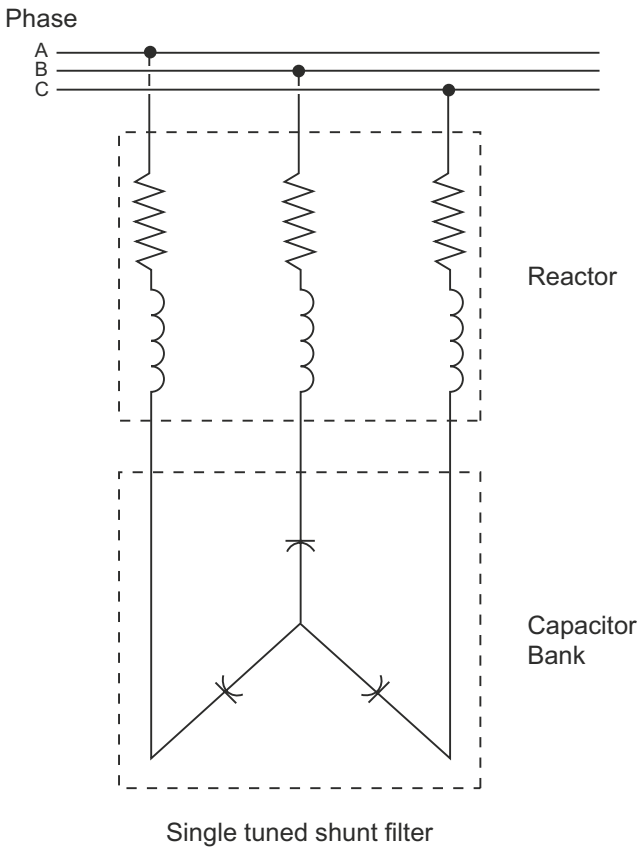

OPERATION

5.1 Current Measurements

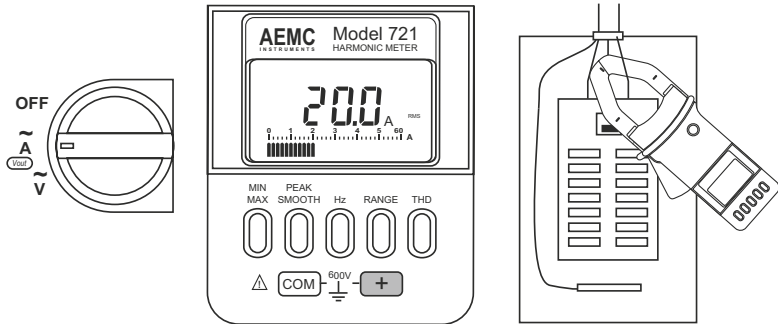

1. Turn the rotary switch to the current measurement function **A~**. Selection is confirmed with a short beep.
2. Press the trigger to open the jaws. Clamp the jaws around the conductor. The most accurate readings are obtained with the conductor aligned with the centering marks on the jaws.
3. Take the reading from the display. Current measurements are possible from 50 mA to 700.0 Arms, and to 999.9 A Peak.

⚠ WARNING ⚠

Although the meter can display up to 999.9 A in Auto Range and in the 600 A manual range, the warning symbol will be displayed above 700 Arms and accompanied by a beeping alarm sound. This indicates that the input exceeds the specified safety and operating range. The displayed value is only indicative and not specified.

Do not continue to operate the instrument when the input value exceeds the meter safety and operating specifications.

OL is displayed above 1000 A peak in the Peak mode and may also be accompanied by the warning triangle if the RMS value exceeds 700 A.

The warning symbol may also be displayed if the input signal is too low (<50 mA) or if the fundamental signal is not 50 or 60 Hz.

5.1.1 Ranging

Auto Ranging is selected by default and selects the best range for the digital display and for the analog bargraph.

Pushing the RANGE push button selects a fixed manual range: 60 Arms first, and 600 Arms on the second push.

The digital display and the bargraph indicate the selected range. RANGE is displayed at the top of the display indicating a manual range selection. Selection is also confirmed with audible tone.

To sequence back to Auto Ranging, push and hold the RANGE push button for approximately 3 seconds. The displayed RANGE indicator will disappear, confirmed with an audible tone.

5.1.2 Analog Output – Vout

In the Current Measurement mode, the Analog Output Vout is always activated in $A\sim$ (see § 5.8) and the 10 mV/A (or 100 mV/A) signal is present at the voltage terminals.

5.1.3 Other Functions

All others push-button functions relating to current may be accessed in A:

- THD (%THD, %DF, CF)
- HZ
- PEAK/SMOOTH
- MIN/MAX recording

These functions are described further in this manual (see p. 16-24).

5.1.4 Bargraph

Please note that the analog bargraph will continue to display RMS current values while other measurement functions are displayed (e.g. %THD, %DF, CF, Hz, Min/Max, Smooth, Peak). The bargraph ranges are 60 Arms and 600 Arms.

5.2 Voltage Measurements

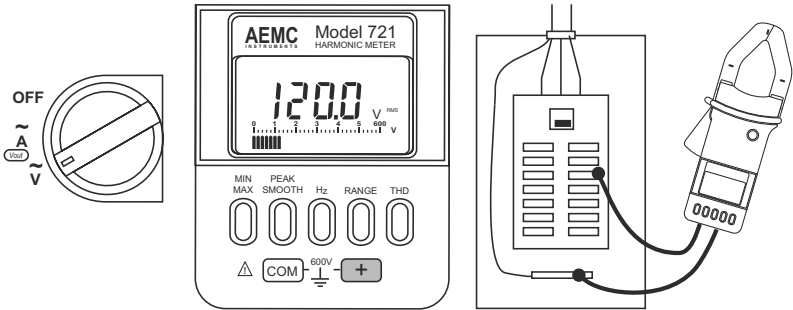

1. Turn the rotary switch to the voltage measurement function $V\sim$. Selection is confirmed with a short beep.
2. Insert the red test lead into the (+) jack and the black test lead into the (COM) jack. Select the appropriate termination (test probes or clips).
3. Touch or connect the voltage test leads to the circuit under test.
4. Take the reading from the display. Voltage measurements are possible from 50 mV to 600 Vrms, and to 999.9 V Peak.

⚠ WARNING ⚠

Though the meter can display to 999.9 V in Auto Range and in the 600 V manual range, the warning symbol will be displayed above 600 Vrms and accompanied by a beeping alarm sound. This indicates that the input exceeds the specified safety and operating range. The displayed value is only indicative and not specified.

Do not continue to operate the instrument when the input value exceeds the meter safety and operating specifications.

OL is displayed above 1000 V peak in the Peak mode and may also be accompanied by the warning triangle if the RMS value exceeds 600 V.

The warning symbol may also be displayed if the input signal is too low (<50 mV) or if the fundamental is not 50 or 60 Hz.

5.2.1 Ranging

Auto Ranging is selected by default and selects the best range for the digital display and for the analog bargraph.

Pushing the RANGE push button will select a fixed manual range: 60 Arms first and 600 Vrms on the second push.

The digital display and the bargraph indicate the selected range. RANGE is displayed at the top of the display indicating a manual range selection. Selection is also confirmed with audible tone.

To sequence back to Auto Ranging, push and hold the RANGE push button for approximately 3 seconds. The displayed RANGE indicator will disappear, confirmed with an audible tone.

5.2.2 Other Functions

All others push-button functions relating to voltage may be accessed in V:

- THD (%THD, %DF, CF)
- HZ
- PEAK/SMOOTH
- MIN/MAX recording

These functions are described further in this manual (see p. 29-36).

5.2.3 Bargraph

Please note that the analog bargraph will continue to display RMS voltage values while other measurement functions are displayed (e.g. %THD, %DF, CF, Hz, Min/Max, Smooth, Peak). The bargraph ranges are 60 Vrms and 600 Vrms.

5.3 THD Push Button: Power Quality Measurements

THD gives access to Power Quality measurements (%THD, %DF, and CF) and can be accessed while in Current or in Voltage.

The THD push button accesses three measurement values by sequentially pressing the button:

Push Button Sequencing:
A or V → %THD → %DF → CF → A or V

5.3.1 %THD: Total Harmonic Distortion

%THD is the Total Harmonic Distortion and referenced to the Fundamental (50/60 Hz) signal. The THD is expressed as a percentage and may be greater in amplitude than the fundamental. A reading greater than 100% is possible. The %THD is also referred to as the Harmonic Factor or %THD-F.

Mathematically, the Total Harmonic Distortion, or %THD, is the ratio of the root-mean-square (RMS) of the harmonic content to the root-mean-square (RMS) value of the fundamental, and expressed as a percentage (see p. 16 for details).

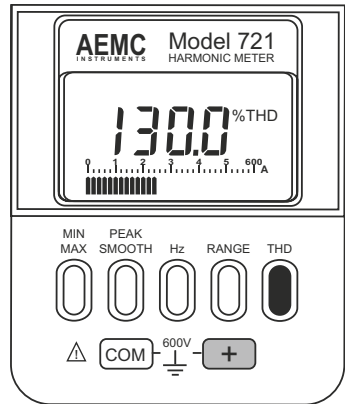

%THD Application Example:

It is possible to calculate total harmonic current from a %THD reading when a true RMS current or voltage is also known. First, solve for the Fundamental current using the following example:

$$\text{Fundamental} = \sqrt{\frac{\text{RMS}^2}{\left(\left(\frac{\% \text{THD}}{100}\right)^2 + 1\right)}}$$

With the value for fundamental current known, we can calculate for the amount of Harmonic Current.

$$\text{Harmonic} = \sqrt{(\text{RMS})^2 - (\text{Fundamental})^2}$$

Example:

The Model 721 measures a RMS value of 230 Amps and THD of 130%. This means that the harmonic content is 130% of the fundamental. Calculate for Total Harmonic current by solving the equations:

$$\text{Fundamental} = \sqrt{\frac{230^2}{\left(\left(\frac{130\%}{100}\right)^2 + 1\right)}}$$

$$\text{Fundamental} = \sqrt{19665} = 140.23\text{A}$$

$$\text{Harmonic} = \left(\frac{\% \text{THD}}{100}\right) \times \text{Fundamental} = 1.3 \times 140.23 = 182\text{A}$$

5.3.2 %DF: Distortion Factor

%DF, or Distortion Factor, is the Total Harmonic Distortion referenced to the total RMS signal.

The Distortion Factor is expressed as a percentage and may not be greater than the fundamental. The %DF never exceeds 100%. The %DF is sometimes referred to as the %THD-R.

Please note that our %DF is not the same value as the Distortion Factor as expressed in the IEEE standard 519-1992 (in which Distortion Factor is the same as THD).

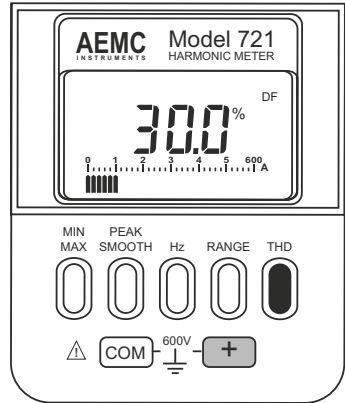

The %DF is a useful term because of the market need to quickly determine the content of Harmonics and the requirement of Harmonics as a percentage of the Total RMS under the international standard IEC-555 and possibly other standards.

Mathematically the Distortion Factor, or %DF, is the ratio of the root-mean-square (RMS) of the harmonic content to the RMS value of the total signal, and expressed as a percentage (see p. 20 for details).

%DF Application Example:

The Model 721 measures an RMS value of 100 A and a DF of 30%. The mathematics below show how to figure out the Harmonic and Fundamental current:

$$\text{Fundamental} = \sqrt{\left(1 - \left(\frac{\%DF}{100}\right)^2\right) \times (\text{RMS})^2}$$

$$\text{Harmonic} = \left(\frac{\text{DF}\%}{100}\right) \times \text{RMS}$$

Using the measured values of RMS = 100A and a DF of 30% we can compute the Harmonic and Fundamental current.

$$\text{Fundamental} = \sqrt{\left(1 - \left(\frac{\%30}{100}\right)^2\right) \times (100)^2}$$

$$\text{Fundamental} = \sqrt{9100} = 95.4\text{A}$$

$$\text{Harmonic} = \left(\frac{30\%}{100}\right) \times 100 = 0.3 \times 100 = 30\text{A}$$

5.3.3 CF: Crest Factor

Crest Factor is the ratio of the Peak value of a waveform to its RMS value. A perfect sine wave has a crest factor of 1.414. In distorted waveforms, the crest factor is typically greater than 1.414 and gives an indication of the harmonic content.

The CF may also be used to determine the CBEMA (Computer & Business Equipment Manufacturers Association) Derating Factor. The CBEMA Derating Factor is used for evaluating the survivability of existing conventional transformers in service and servicing single-phase nonlinear loads such as PCs, computer terminals or other office equipment. For further use of the CBEMA Derating Factor, contact CBEMA directly.

It should be noted that there is no direct or useful relationship between the CBEMA Derating Factor, the %THD and Transformer K Factor (IEEE C57.110-1986).

$$\text{Crest Factor: CF} = \text{Peak} / \text{RMS}$$

$$\text{CBEMA Derating Factor} = 1.414 \times \text{RMS/Peak} = 1.414/\text{CF}$$

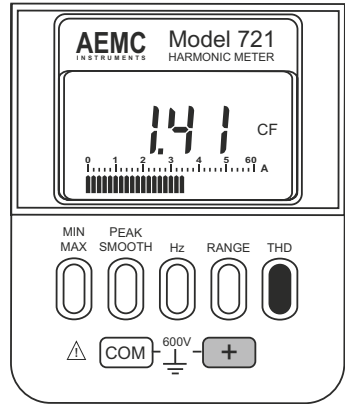

5.3.4 Bargraph

Please note that the analog bargraph will continue to display Arms or Vrms while THD function measurement values (%THD, %DF, CF) are displayed. The Range button only changes the bargraph ranges while in the THD function.

5.4 Range Push Button: Manual Ranges

Pressing the RANGE push button enables you to exit the auto-ranging mode and enter manual ranges. RANGE operates in either current or voltage.

In Amps:

Pushing the RANGE push-button will select a fixed manual range: 60 Arms first and 600 Arms on the second push. The digital display and the bargraph indicate the selected range. RANGE is displayed at the top of the display indicating a manual range selection. Selection is also confirmed with an audible tone.

To sequence back to Auto Ranging, push and hold the RANGE push-button for approximately 3 seconds. The displayed RANGE indicator will disappear, confirmed with an audible tone.

The bargraph ranges are 60 Arms and 600 Arms and are also manually selected. The analog bargraph will continue to display present values while other measurement functions are displayed.

In Volts:

Pushing the RANGE push-button will select a fixed manual range: 60 Vrms first and 600 Vrms on the second push. The digital display and the bargraph indicate the selected range. RANGE is displayed at the top of the display indicating a manual range selection. Selection is also confirmed with an audible tone.

To sequence back to Auto Ranging, push and hold the RANGE push-button for approximately 3 seconds. The displayed RANGE indicator will disappear, confirmed with an audible tone.

The bargraph ranges are 60 Vrms and 600 Vrms, and are also manually selected. The analog bargraph will continue to display present values while other measurement functions are displayed.

5.5 Hz Push Button: Frequency Measurement

The Hz push button accesses the frequency function while in either current or in voltage.

Frequency measurements are possible from 0.5 Hz to 9999 Hz.

Frequency measurements are always Auto Ranging. Pushing the RANGE push button will only select a fixed range of either 60 or 600 (A or V) on the bargraph. The RANGE indicator is displayed at the top of the digital display indicating fixed A or V range selection on the bargraph. Selection is confirmed with an audible tone.

To sequence back to Auto Ranging, push and hold the range selection push-button for approximately 3 seconds. Displayed RANGE indicator will disappear, confirmed with an audible tone.

PEAK/SMOOTH push-button is active in Hz but only the Smooth feature is available. Peak does not exist in Hz measurements (see PEAK/SMOOTH Push Button, § 5.6). MIN/MAX is active in Hz (see MIN/MAX Push Button, § 5.7).

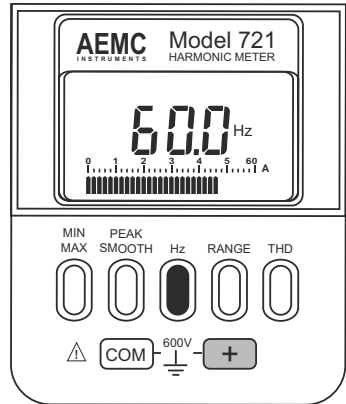

If while measuring frequency on a 60 Hz system, the Model 721 indicates 180 Hz, then the third harmonic is dominant and exceeds the fundamental in magnitude. This may occur in office settings on single-phase loads or on lighting ballasts. The Model 721 measures the frequency of the signal with the greatest amplitude.

The analog bargraph will continue to display Arms or Vrms depending upon which input function is selected.

⚠ The HZ function must be exited in order to select another measurement function. Hz is exited by pressing the Hz push-button briefly. A brief beep will be emitted.

5.6 Peak/Smooth Push Button

Peak/Smooth functions are accessed with this push button. Control is verified with a short beep. Peak and Smooth functions may be used for voltage and current measurements. In THD functions and Hz measurement mode, only Smooth is active. The PEAK and SMOOTH are reached by sequentially pressing the push button.

Smooth and Peak are selected by sequentially pressing the Peak/Smooth push button.

Push Button Sequencing:

In A or V: A or V → Smooth → Peak → A or V

In THD: THD function → Smooth → THD Function

In Hz: Hz → Smooth Hz

5.6.1 Smooth

Smooth stabilizes the digital readings when measurements are fluctuating. In this mode, the Model 721 calculates and displays a three-second average reading.

Smooth may be used in Volts, Amps, Frequency, as well as power quality functions (%THD, %DF, CF). Smooth may also be used while in the MIN/MAX recording mode.

The analog bargraph will not be affected by the Smooth functions and continues to display Arms or Vrms.

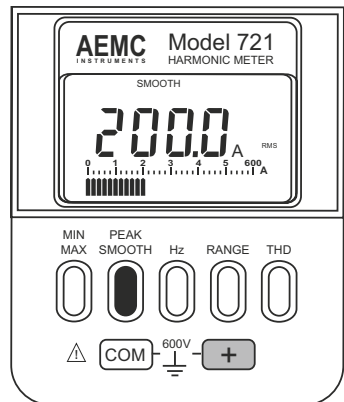

5.6.2 Peak

Peak is a fast responding function which measures the instantaneous (1ms) Peak values of the measured signal. This function is often used for half cycle in-rushing signals. The Peak function is displayed in the lower right-hand corner of the display next to the measurement symbol.

Peak may also be accessed when recording. When recording MIN/MAX, depressing PEAK gives the MAX Peak only.

The bargraph also indicates the Peak values. When a Peak value exceeds the bargraph scale, an arrow at the end of the scale (▶) is displayed. When in MAX Peak, the MAX Peak value blinks while the bargraph continues to respond in Peak mode.

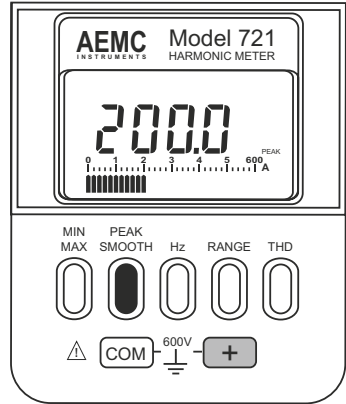

5.7 MIN/MAX Push Button: Recording Function

The recording feature allows the user to record the Minimum (MIN), Maximum (MAX), Average (AVG), and Maximum Peak (MAX Peak) measurement values.

By pressing the MIN/MAX push button sequentially, the measurements are displayed. Recording is possible in A, V, %THD, %DF, CF, and HZ.

If SMOOTH is selected prior to RECORDING, the smoothed values are recorded.

Push Button Sequencing:

In A or V: A or V Max → Min → Avg → A or V

In A or V Peak: A or V Peak → Max Peak → A or V Peak

In THD Functions: THD Function → Max → Min → Avg → THD Function

In Hz: Hz → Max → Min → Avg → Hz

Note: The same operations apply with SMOOTH turned on

Recording is initiated with the MIN/MAX push button during the selected measurement function. RECORD indication will blink 1/second during the record mode. Control is verified with a short beep.

Recording is possible for up to 24 hours when using a fresh battery, and limited to 8 hours in %THD and %DF.

During record mode, a beep indicates the capture of each new minimum and maximum value. When recording current or voltage measurement information, specific segments on the analog bargraph will blink indicating the current status of the MIN and MAX values.

In MIN/MAX Recording, the bargraph indicates Arms or Vrms. The MIN and MAX values are also indicated and blink.

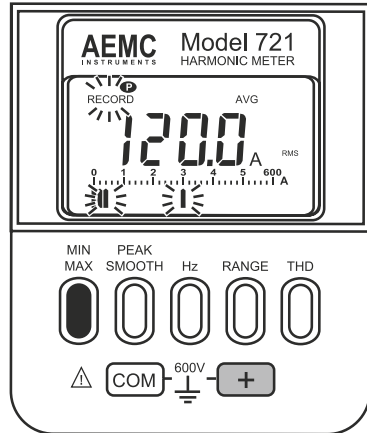
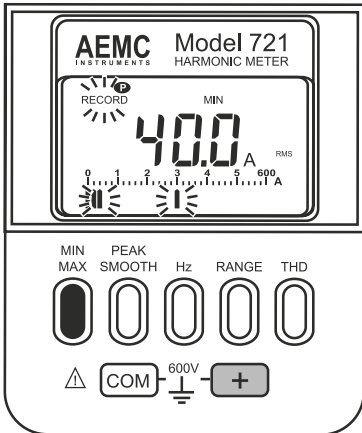
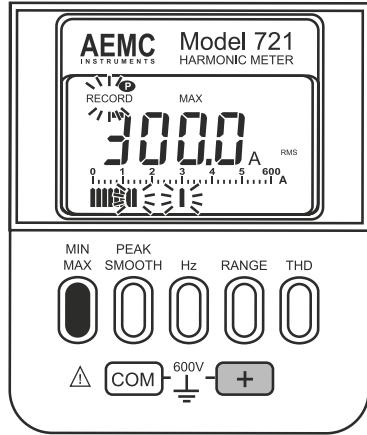
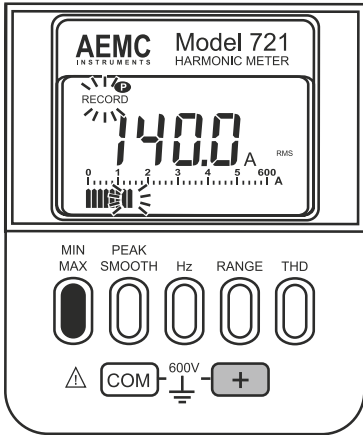

Recording mode is stopped manually at any time by pushing the **HOLD** button. RECORD-PAUSE will then be displayed, and the record indication will no longer blink. At this point, recorded measurement can be read by pushing the MIN/MAX push button sequentially. The bargraph blinks on the MIN and the MAX values. To resume recording, press HOLD again.

When recording PEAK measurements, only MAX PEAK measurement values are stored in memory, and the bargraph indicates Peak values and blinking MAX Peak.



Before accessing any other functions, you must exit MIN/MAX Recording by pushing and holding the MIN/MAX push button a few seconds until it beeps. The beep will indicate the mode change and the displayed RECORD symbol will disappear.

5.8 Vout – Analog Output

When measuring current or current power quality, the Model 721 automatically provides an analog output (1 mV/A or 10 mV/A) through the voltage terminals.

This function enables the user to display the actual current waveform on any oscilloscope or hand-held scope. You can take measurements on the clamp-on and visualize the signal waveform on the oscilloscope.

Vout is always present when in A~. The analog output is independent and does not interfere with the current or power quality measurements (%THD, %DF, CF, Hz, Min/Max, Peak).

An insulated banana jack to BNC connector is supplied with the instrument. Use your BNC lead and scope. In essence, you have a free current harmonic transducer for oscilloscopes or hand-held scopes, or even a current transducer for loggers and recorders.

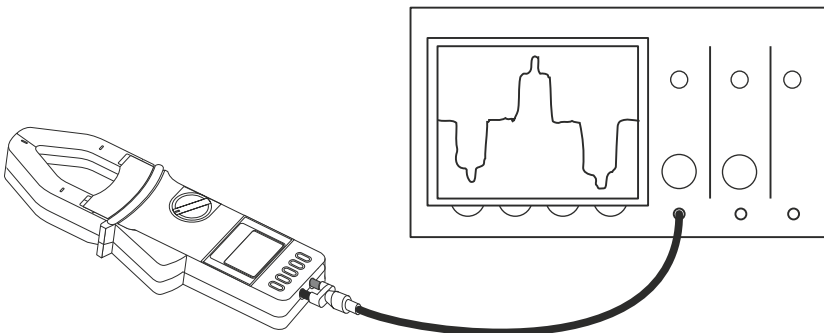

1. Disconnect the probe from all circuits and turn the meter OFF.
2. Connect the insulated BNC connector to the voltage jacks (**red** to **+** and **black** to **COM**).
3. Connect your BNC cable to the insulated BNC jack and to your oscilloscope.
4. Turn the rotary switch to the current measurement function **A~**. Selection is confirmed with a short beep.
5. Press the trigger to open the jaws. Clamp the jaws around the conductor. The most accurate readings are obtained with the conductor aligned with the centering marks on the jaws.
6. Adjust the oscilloscope range for the desired waveform size and display. Readings from the Model 721 are also valid. The analog output is preset to 1 mV/A at the factory and permits current measurements from 50 mA to 700.0 Arms, and to 999.9 A Peak.

5.8.1 Output Level

The output is preset at 1 mV/A at the factory. We recommend that you use the oscilloscope amplification rather than changing the 1 mV/A output in order to benefit from the full 700 Arms operating range. The 10 mV/A is limited to 60 Arms.

Analog output may be switched internally to either 1 mV per A or 10 mV per A. The selection is made internally by a mini switch located under the input terminal circuit card found on the base of the instrument (refer to the diagram on p. 42).

Extreme care should be exercised when changing the mini switch selection to avoid damaging internal components or wires. This procedure should only be performed by qualified service personnel.

5.9 Summary of Accessible Functions

	Smooth	Peak	MAX	MIN	AVG	MAX Peak
Arms	Yes	Yes	Yes	Yes	Yes	Yes
Vrms	Yes	Yes	Yes	Yes	Yes	Yes
%THD	Yes	No	Yes	Yes	Yes	No
%DF	Yes	No	Yes	Yes	Yes	No
CF	Yes	No	Yes	Yes	Yes	No
Hz	Yes	No	Yes	Yes	Yes	No

5.10 Auto-Off Feature

The Model 721 will automatically shut itself off after 10 minutes during the following conditions:

- No push button action
- No rotary switch (A ,V) action
- No measurement change
- Not in Record Min/Max mode

A short beep will be heard prior to shutdown. Any control action will re-power the instrument.

The Auto-Off feature may be disabled by holding down the RANGE push button, while turning the rotary selection switch from OFF to either Amps or Volts.

P will be displayed in the upper left-hand corner of the LCD when the Auto-Off feature has been disabled.

The Auto-Off feature will be reset when the Model 721 is turned off.

5.11 Troubleshooting

From time to time, a minor malfunction may occur due to normal operating events. Below are common events and solutions which should help you troubleshoot your Model 721.

Symptom	Recommended Action
Instrument will not turn on	Low battery; replacement required
Missing or inaccurate readings	Check that minimum input level is present; Check that the transformer mating surfaces are clean
No function control action; High frequency beep(s)	Exit current mode with push button; Instrument may be beyond safety or operating range

CHAPTER 6

MAINTENANCE

WARNING

- To avoid electrical shock, do not attempt to perform any servicing unless you are qualified to do so.
- To avoid electrical shock and/or damage to the probe, do not get water or other foreign agents into the case. Turn the Model 721 OFF and disconnect the meter from all circuits and inputs before opening the case.

6.1 Cleaning

- Wipe the case and jaw covers with a damp cloth and mild detergent.
- Do not use abrasives or solvents.
- If rusted, sand with very fine sandpaper, then lightly oil. Wipe off excess oil to prevent it from dripping into the case.

6.2 Battery Test & Replacement

To determine useful battery life, a self-test may be initiated by holding down any push button while turning the rotary selector from the OFF position to Amps or Volts.

All indicators will light up. The Battery symbol, as well as battery segment indicator, will blink indicating useful battery life remaining.

A full bargraph display represents 60 hours of useful battery life. Each bar segment represents approximately two hours of battery life.

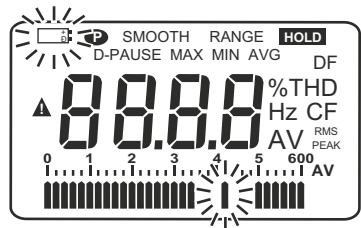

It is considered good practice to replace any battery with only a few hours of life remaining.

Power Source: 9V Alkaline battery (NEDA 1604, 6LF22, 6LR61)

Source Life: 50 hr continuous use approx

6.2.1 Battery Replacement

1. The instrument must be OFF and disconnected from any circuit or input.
2. Place the meter face down and remove the three Phillips screws on the back of the instrument.

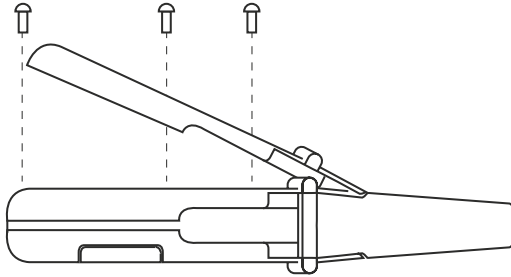

3. Remove the back cover by pulling it down and away from the instrument.
4. Lift the battery away from the case and disconnect the battery.
5. Connect the new battery and position the leads so that they won't get pinched when the cover is replaced.
6. Replace the back cover, noting that it slips beneath the hold-down lip and fits securely into position. Take care to position any loose wire or circuit correctly before closing.
7. Install and tighten the three screws.

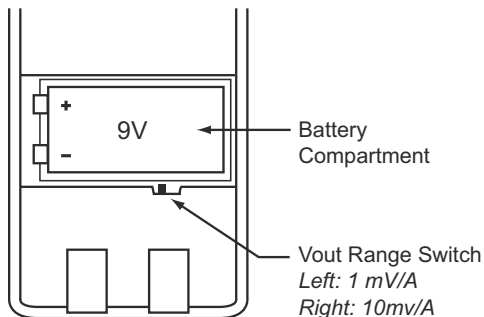

Repair and Calibration

To ensure that your instrument meets factory specifications, we recommend that it be submitted to our factory Service Center at one-year intervals for recalibration, or as required by other standards or internal procedures.

For instrument repair and calibration:

You must contact our Service Center for a Customer Service Authorization Number (CSA#). This will ensure that when your instrument arrives, it will be tracked and processed promptly. Please write the CSA# on the outside of the shipping container. If the instrument is returned for calibration, we need to know if you want a standard calibration, or a calibration traceable to N.I.S.T. (Includes calibration certificate plus recorded calibration data).

Chauvin Arnoux[®], Inc.
d.b.a. AEMC[®] Instruments
15 Faraday Drive
Dover, NH 03820 USA
Tel: (800) 945-2362 (Ext. 360)
(603) 749-6434 (Ext. 360)
Fax: (603) 742-2346 or (603) 749-6309
repair@aemc.com

(Or contact your authorized distributor)

Costs for repair, standard calibration, and calibration traceable to N.I.S.T. are available.

NOTE: All customers must obtain a CSA# before returning any instrument.

Technical and Sales Assistance

If you are experiencing any technical problems, or require any assistance with the proper operation or application of your instrument, please call, mail, fax or e-mail our technical support hotline:

Chauvin Arnoux[®], Inc.
d.b.a. AEMC[®] Instruments
200 Foxborough Boulevard
Foxborough, MA 02035, USA
Phone: (800) 343-1391
(508) 698-2115
Fax: (508) 698-2118
techsupport@aemc.com
www.aemc.com

NOTE: Do not ship Instruments to our Foxborough, MA address.

Limited Warranty

The Model 721 is warranted to the owner for a period of one year from the date of original purchase against defects in manufacture. This limited warranty is given by AEMC® Instruments, not by the distributor from whom it was purchased. This warranty is void if the unit has been tampered with, abused or if the defect is related to service not performed by AEMC® Instruments.

For full and detailed warranty coverage, please read the Warranty Coverage Information, which is attached to the Warranty Registration Card (if enclosed) or is available at www.aemc.com. Please keep the Warranty Coverage Information with your records.

What AEMC® Instruments will do:

If a malfunction occurs within the one-year period, you may return the instrument to us for repair, provided we have your warranty registration information on file or a proof of purchase. AEMC® Instruments will, at its option, repair or replace the faulty material.

**REGISTER ONLINE AT:
www.aemc.com**

Warranty Repairs

What you must do to return an Instrument for Warranty Repair:

First, request a Customer Service Authorization Number (CSA#) by phone or by fax from our Service Department (see address below), then return the instrument along with the signed CSA Form. Please write the CSA# on the outside of the shipping container. Return the instrument, postage or shipment pre-paid to:

Chauvin Arnoux®, Inc. d.b.a. AEMC® Instruments
Service Department
15 Faraday Drive • Dover, NH 03820 USA
Tel: (800) 945-2362 (Ext. 360)
(603) 749-6434 (Ext. 360)
Fax: (603) 742-2346 or (603) 749-6309
repair@aemc.com

Caution: To protect yourself against in-transit loss, we recommend you insure your returned material.

NOTE: All customers must obtain a CSA# before returning any instrument.



11/03

99-MAN 100066 v2