

Cleaning Water Naturally™

OWNER'S MANUAL FOR:



## SW20 & SW40 Pond Series Shallow Water Aeration Systems

## CONTENTS

SECTION

System Components	1
Safety	2
Seasonal Operation	3
System Installation	4
Maintenance	5
Troubleshooting	6
Replacement Parts	7
Warranty	8

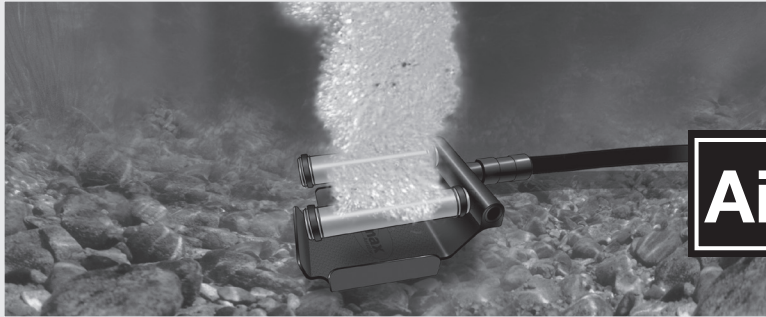

Air

## THANK YOU FOR CHOOSING The Airmax® Aeration System

You have purchased the most efficient and cost-effective aeration system available on the market today!

### 1. System Components

#### Airmax® Composite Cabinet

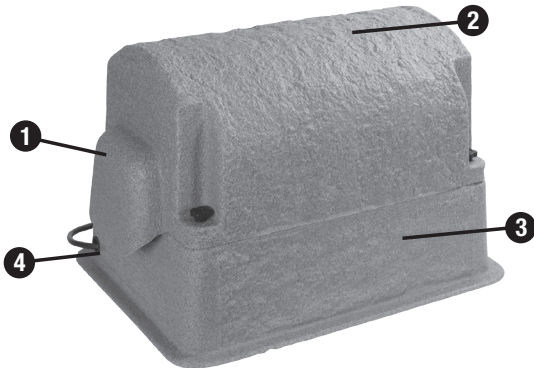

1. Enhanced cooling system tunnels air flow evenly through the cabinet with a high flow cooling fan & high density air intake pre-filter.
2. Composite cabinet with removable top protects components while providing easy access
3. Elevated base protects against damaging flood water
4. Pre-wired electrical box simplifies electrical connections for easy setup

**Cabinet Size: 23"L x 17"W x 15"H**

#### SilentAir™ LR Series Linear Diaphragm Compressor



1. High efficiency, linear diaphragm compressor
2. Air Filter maximizes the life of the compressor
3. Rubber compressor mounts reduce noise and vibration for silent operation
4. Airflow manifold simplifies airflow management to individual diffusers
5. Heat-resistant, 3/8" flex-tube protects against high temperatures of the compressor
6. Airline quick disconnects for easy system removal and storage

#### ProAir™ 2 Weighted Diffuser

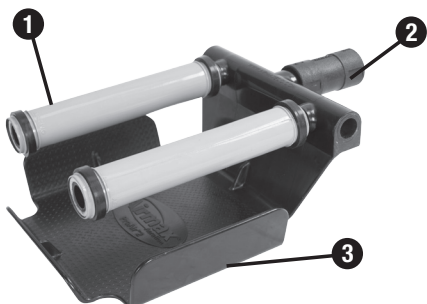

1. PTFE non-stick membrane diffuser sticks provides the synergy of air stones while being virtually maintenance-free
2. Check valve prevents back pressure to compressor
3. Weighted design keeps diffuser submerged while maintaining an upright position during installation

**Diffuser Size: 15"L x 9.25"W x 3.75"H**

#### EasySet™ AIRLINE

- Self-Weighted Airline: 3/8" 100' Roll (#510118), 5/8" 100' Roll (#510119): Lead-free weighted airline is made of durable PVC composite. Fish hook resistant and kink-free. Use from pond's edge to diffuser.
- Direct Burial Airline (sold separately): 5/8" 100' Roll (#510120) Flexible, yet kink-free. Bury from cabinet and compressor to pond's edge when placing the cabinet and compressor away from the pond.

\* Depending on the type of installation, additional connector kits may be required. See section 7 for connector kits.



## 2. Safety

### SAFETY

- Read all operating instructions carefully.
- To reduce the risk of electric shock, connect only to a properly grounded, grounding-type receptacle. If in doubt, have the outlet checked by a qualified electrician.
- This unit is to be used in a circuit protected by a ground fault circuit interrupter (GFCI).
- Disconnect unit from power source before handling or maintenance.
- Repair or exchange of cable/power cord must be carried through by the supplier/manufacturer.
- This unit has not been investigated for use in swimming pool areas.

### CAUTION

- Never connect to an extension cord. This may result in equipment failure.
- Do not allow anything to rest on the power cord.
- Do not place the cabinet where people may step on the power cord.
- Never override or "cheat" electrical or mechanical interlock devices.
- Never attempt any maintenance function that is not specified in the user manual.
- Never operate the system if unusual noises or odors are detected. Disconnect the power cord from the outlet and call for service.

### GROUNDING INSTRUCTIONS

This product must be grounded. In the event of an electrical short circuit, grounding reduces the risk of electric shock by providing an escape wire for the electric current. This product is equipped with a cord having a grounding wire with an appropriate grounding plug. The plug must be plugged into an outlet that is properly installed and grounded in accordance with all local codes and ordinances.

**WARNING** – Improper installation of the grounding plug is able to result in a risk of electric shock. When repair or replacement of the cord or plug is required, do not connect the grounding wire to either flat blade terminal. The wire with insulation having an outer surface that is green with or without yellow stripes is the grounding wire.

### For 120 VAC products:

This product is for use on a nominal 120V circuit, and has a grounding plug similar to the plug illustrated in sketch A in Figure below. A temporary adapter similar to the adapter illustrated in sketches B and C may be used to connect this plug to a 2-pole receptacle as shown in sketch B when a properly grounded outlet is not available. The temporary adapter shall be used only until a properly grounded outlet (sketch A) is installed by a qualified electrician. The green colored rigid ear, lug, or similar part extending from the adapter must be connected to a permanent ground such as a properly grounded outlet box cover. Whenever the adapter is used, it must be held in place by a metal screw.

### For 230 VAC products:

This product is for use on a circuit having a nominal rating more than 120 V and is factory-equipped with a specific electric cord and plug for connection to a proper electric circuit. Only connect the product to an outlet having the same configuration as the plug. Do not use an adapter with this product. When the product must be reconnected for use on a different type of electric circuit, the reconnection shall be made by qualified service personnel.

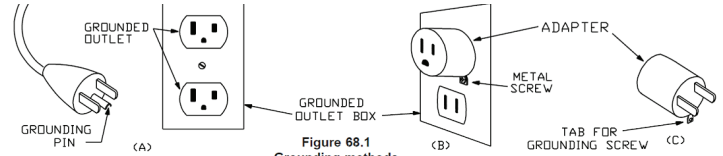

## 3. Seasonal Operation

The circulation of poor quality, low oxygen, deep water to the pond's surface can introduce harmful gases and by-products into the previously healthy upper regions of the water column. These by-products can make the upper regions unfit for aquatic life and could result in fish-kill.

### To Prevent Initial Fish-Kill:

Follow this procedure anytime system has been shut-off for an extended period of time.

- Day 1: Run system for 30 minutes; turn system off for remainder of time.
- Day 2: Run system for 1 hour; turn system off for remainder of day.
- Day 3: Run system for 2 hours; turn system off for remainder of day.
- Day 4: Run system for 4 hours; turn system off for remainder of day.
- Day 5: Run system for 8 hours; turn system off for remainder of day.
- Day 6: Run system for 16 hours; turn system off for remainder of day.
- Day 7: Begin running system 24 hours/day, 7 days/week.

### Summer Operation

To reduce the risk of fish kills in hot summer months and for optimum aeration benefits, Airmax® Aeration Systems should run continuously throughout the summer. To enhance pond health, reduce mucky bottoms and enhance pond's aesthetic appeal, try Pond Logic® products:

**Ma** MuckAway™ **Pd** PondClear™ **Nb** Nature's Blue™ **Bk** Black DyeMond™ **Tw** Twilight Blue™

### Winter Operation

Owner assumes all responsibility for operating Airmax® Aeration System during winter months. Operating in freezing conditions on an ice-covered pond will cause large open water areas at diffuser sites. Ice thickness around open areas will be much thinner than the surrounding areas. Airmax® strongly recommends that "Danger - Thin Ice" be posted at frequent intervals around pond. Diffuser plates should be moved out of the deepest points of pond to allow a safe zone for fish dormancy and to avoid "super cooling" effect.

If you choose to turn your system off for the winter, do the following:

- Unplug your aeration system.
- Disconnect compressor flex-tube(s) from airline(s).
- Cover airline ends with included caps to prevent debris from entering airline.
- Move cabinet and compressor inside to keep dry.
- When turning system back on in spring, airlines may contain ice.
  - Use 1 cup denatured alcohol in the airline running out to each plate.
  - Turn on compressor to push through line and free any ice blockage.
  - Follow initial startup procedure to avoid "shock" in the pond.

**WARNING:** Wrap cord neatly in or under enclosure when not in use to prevent off-season damage.

## 4. System Installation

For quick, easy and professional installations, it is suggested that the following materials be on-site: (None of the following are included with the Airmax® Aeration System)

- Placement Rope
- Level
- Coast Guard-approved life jacket
- Shovel
- Flathead screwdriver
- Utility razor knife
- Boat/Raft/Swimsuit
- Small stone or gravel
- Rake
- Sharpie® Marker

### Location

- Locate cabinet on a solid support with adequate strength for weight of unit.
- Locate cabinet away from irrigation sprinklers.
- Wear a Coast Guard-approved life jacket; follow all safety and caution guidelines.

**WARNING:** All compressor cabinets must be located above the water level.

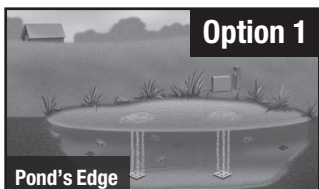

**Option 1:** When power source is available at pond's edge, simply connect one end of EasySet™ Airline to flex-hose and other end to diffuser plate. Steps 2 & 3 below are not necessary using this option.

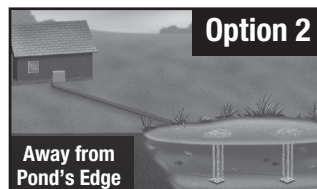

**Option 2:** When power source is not available at pond's edge, place SilentAir™ Cabinet next to nearest power source. Trench Direct Burial Airline (sold separately, ½" standard irrigation pipe may be substituted) from flex-tube to pond's edge; then connect to EasySet™ Airline and run to diffuser plate. Each diffuser will be a separate run of airline. Each run may not exceed several hundred feet.

## 6 Easy Steps!

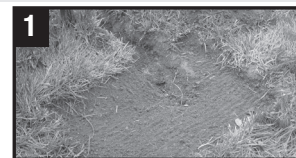

1. Decide on a location for the cabinet and prep ground. May be placed several hundred feet from shoreline (using direct burial airline) if power is not available at shore.



2. **Option 2 Only:** Excavate trench to a minimum of 8" of depth for direct burial line. Place and backfill all direct burial airline (one line per diffuser).



3. **Option 2 Only:** Connect direct burial airline to EasySet™ self-weighted airline.



4. Connect diffuser to airline. Extend EasySet™ self-weighted airline to proper location. Place diffuser. To ensure proper placement, use nylon rope. Plates should be located towards the deepest part of the pond.



5. Connect airline to flex lines supplied with cabinet. Open cabinet, plug compressor and cooling fan into power control. Plug power control cord into power outlet. Flip power switch to the ON position.

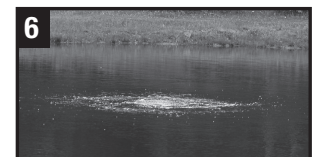

6. Bubbles should be noticeable from all diffuser locations. When more than one diffuser is installed, adjust valves for maximum performance. Once adjustments are made, wait several minutes to see results at the diffuser location(s). Deeper placement of plate(s) and longer runs of tube will require more flow.

## 5. Maintenance\*\*

Airmax® Aeration Systems are designed for low-maintenance and require minimal scheduled maintenance. Cabinet inlets and outlets should be kept free of debris and weed growth allowing normal ventilation.

- Always unplug system before performing any maintenance or troubleshooting.
- Always unplug system and refer servicing to a qualified electrician when: cord is damaged or frayed, compressor, power control, compressor fan, or other electrical components are producing unusual noises or odors.
- Always use parts that are supplied or approved by Airmax®, Inc. Use of other parts may result in poor performance and could create a hazardous situation.

\*\*Local environmental conditions may require more frequent maintenance.

**WARNING:** Compressors are equipped with a thermal overload switch. If temperature becomes high enough to trip the overload, the compressor will shut down. It will then automatically start up when temperature decreases as long as power is applied.

**EVERY 3-6 MONTHS - Air Filter:** Clean/replace air filter. **Cooling Fan:** Check to ensure cooling fan is operating. Hot air should be pulled from cabinet, not cool air blowing in.

**Pressure Gauge:** Mark pressure gauge upon initial start up. Check to verify pressure has not significantly risen above or dropped below initial reading. Normal operation will range between 5-10 psi.

**Pressure Relief Valve:** Check to ensure air is not escaping from valve. If unit is shut off, pressure will need to be released from the system in order for compressor to restart.

**EVERY 12 MONTHS - Membrane Sticks:** Purge membrane sticks. For SW20 & SW40, while compressor is running, shut off all air flow valves except one, forcing all air to one diffuser plate for 10 seconds. Repeat for each plate.

**EVERY 12-24 MONTHS - Maintenance Kit:** It is recommended to install a maintenance kit every 18-24 months to ensure optimum performance.

## 6. Troubleshooting

### IF COMPRESSOR IS NOT OPERATING:

ISSUE	CHECK	LIKELY CAUSE	CORRECTION
Cabinet fan is not running.	Option 1: GFCI circuit tripped.	Damage to electrical cord or low voltage from power supply.	Contact Airmax® or local dealer for electrical troubleshooting assistance.
	Option 2: GFCI circuit not tripped.	GFCI malfunction.	
Cabinet fan is running.	Option 1: Check compressor capacitor wiring for frays or poor connections.	Wiring loosened or was damaged during shipment or maintenance.	Contact Airmax® or local dealer for repair/replacement.
	Option 2: No capacitor wiring issues can be seen.	Bad capacitor.	
	Option 3: Capacitor has been replaced.	Compressor is bad.	

### IF COMPRESSOR IS OPERATING:

ISSUE	CHECK	LIKELY CAUSE	CORRECTION
No bubbles at any diffusers.	Option 1: No air leaks are audible in cabinet. Compressor running louder and possible excessive vibration.	Compressor air filter is dirty/clogged.	Clean or replace air filter. <b>NEVER</b> re-install wet filter.
	Option 2: Compressor operating normally or making unusual noises. Exhibits reduced pressure and/or air flow.	Compressor needs <b>diaphragm maintenance kit</b> and possibly new air filter.	Contact Airmax® or local dealer with specifications for <b>maintenance kit</b> . Clean or replace air filter. <b>NEVER</b> re-install wet filter.
No bubbles at some diffuser plates.	Option 1: Check for leaks at all connections in line and in cabinet. If none are audible, carefully spray <b>SMALL</b> amount of soapy water onto connections and look for bubbles.	Vibration loosened connection or cracked fitting.	Tighten loose connection or replace cracked fitting as necessary.
	Option 2: Are all flow control valves in compressor wide open?	Improper "balancing" of diffusers.	Adjust air flow valves on manifold in cabinet until all diffusers operate properly. <b>See Section 4. System Installation</b> for more information.
	Option 3: Valves in cabinet are properly "balanced" and no leaks are evident.	Compressor beginning to lose compression and needs <b>diaphragm maintenance kit</b> .	Contact Airmax® or local dealer with compressor specifications for <b>maintenance kit</b> .
Large rolling bubbles instead of fine bubbles at surface above one or more diffuser plates.	Inspect each diffuser plate for malfunction.	Diffuser membrane damaged, diffuser plate fitting broken or diffuser plate is flipped over.	Contact Airmax® or local dealer for repair/replacement.
Air coming out of pressure relief valve.	Option 1: High pressure reading on gauge. Inspect diffuser plates and tubing for clogging.	Diffuser maintenance needed.	Remove any overgrowth around diffuser membrane surface. <b>See Section 5. Maintenance</b> for more information.
	Option 2: Low pressure reading on gauge. Diffuser plates not clogged.	Bad pressure relief valve.	Contact Airmax® or local dealer for repair/replacement.
Compressor stops working for periods of time, then restarts.	Inspect cooling fan for proper function.	Compressor over-heating due to bad cooling fan.	Contact Airmax® or local dealer for fan replacement. If possible, leave top of cabinet open for cooling. Otherwise, unplug system until fan is replaced.
Compressor shakes erratically and is making loud noises.	Option 1: Check for low voltage while compressor is running.	Gauge of supply wires to circuit possibly undersized or cabinet is plugged into extension cord.	If gauge of circuit wiring is incorrect, have electrician replace. <b>NEVER</b> use extension cord to operate system for continual use.
	Option 2: Check for clogged air filter.	Air filter in need of replacement.	Clean or replace air filter. <b>NEVER</b> re-install wet filter.

## 7. Replacement Parts

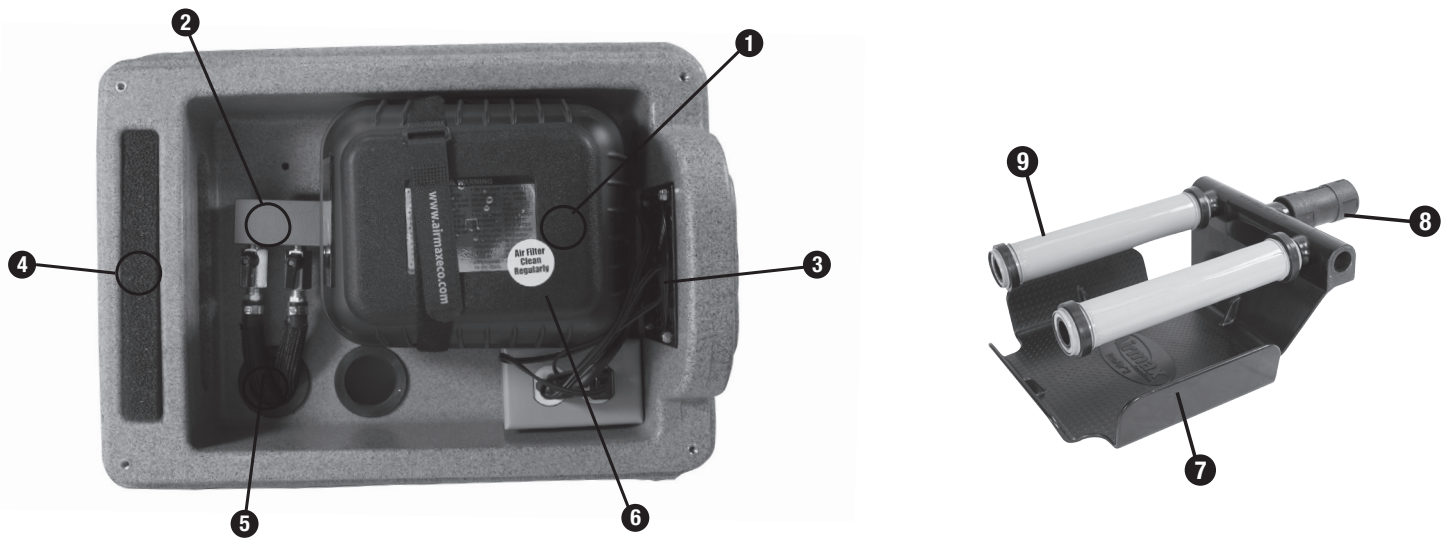

### Cabinet & Compressor Replacement Parts

#### 1. High Efficiency Compressor

- #120912 – SilentAir™ LR25 Linear Diaphragm Compressor
- #120913 – SilentAir™ LR50 Linear Diaphragm Compressor
- #510147 – SilentAir™ LR25 Diaphragm Maintenance Kit
- #510148 – SilentAir™ LR50 Diaphragm Maintenance Kit

#### 2. Airflow Manifold Assembly

- #600177 – SW20 Airflow Manifold Assembly
- #600178 – SW40 Airflow Manifold Assembly

3. #510302 – Cooling Fan for 115V Systems

4. #510395 – Air Intake Pre-Filter

5. #490194 – 3/8" Flex-Tube Assembly

#### 6. Air Filter

- #510150 – Air Filter, Complete
- #510151 – Air Filter Media Only

### ProAir™ 4 Replacement Parts

- 7. #490333 – Diffuser Sled
  - 8. #490340 – Check Valve
  - 9. #510168 – PTFE 6" Membrane Stick
  - \*#490158 – Marine Stainless Hose Clamp
  - \*#490118 – 1/2" to 3/4" Insert Reducer Adapter
  - \*#490118 – 3/8" to 3/4" Insert Reducer Adapter
- \*Not shown in Diagram*

### EasySet™ Airline

- #510118 – 3/8" Weighted Airline, 100' Roll
- #510119 – 5/8" Weighted Airline, 100' Roll
- #510120 – 5/8" Direct Burial Airline, 100' Roll

### Connector Kits



3/8" Connector Kit  
#490204



3/8" to 5/8" Connector Kit  
#490205



5/8" Connector Kit  
#490206

## 8. Warranty

Airmax®, Inc. warrants to the original purchaser (the end user) of any Airmax® Aeration System manufactured by Airmax®, Inc. that any aeration system component which proves to be defective in materials or workmanship, as determined by the factory within the timeframe specified below from the shipping date, will be repaired or replaced at no charge with a new or remanufactured part, and returned freight prepaid. The end user shall assume all the responsibility and expense for removal, packaging, and freight to ship to Airmax®, Inc. to determine the warranty claim and for all reinstallation expenses.

- Cabinet – Lifetime
- Compressor – 2 Years
- Airline & Diffusers – 5 Years

The warranty is void in cases where damage results from: improper installation, improper electrical connection, improper voltage, alteration, lightning, careless handling, misuse, abuse, disassembly of motor or failure to follow maintenance or operating instructions. Modification or repair by an unauthorized repair facility will void the warranty. Compressor seals, diaphragms, air filters and diffuser membranes are considered wear parts and are not covered under warranty.

There is a metallic sticker on the side of the compressor and the electrical box similar to what you see on the right. For your records, copy the appropriate number below. Have this information ready when making inquiries regarding your Airmax® Aeration System.

#### PURCHASE DATE:

Date unit was purchased. (Example: June 1, 2014)

WARRANTY VOID IF REMOVED

#####

AIRMAX®, INC.  
WWW.AIRMAXECO.COM

THANK YOU FOR CHOOSING



Cleaning Water Naturally™

Airmax®, Inc.  
www.airmaxeco.com  
866.424.7629

