

Electrolux Blast Chillers

Blast Chillers - 28 kg

Chilling means bringing the temperature of cooked food from +90°C to +3°C in a short time lap which does not allow bacterial growth. Electrolux Blast Chillers reduce temperature from +90°C to +3°C at food core in less than 90 minutes: the models detailed on this sheet performs this cycle up to a 28 kg full load. After the Blast Chilling a holding cycle starts automatically to maintain food at +3°C. Blast chilled food has a solid 5 days shelf life without loss of flavour, nutritional values and weight. The opportunity to prepare in a single shot the food to be used in different times during the week enables a better work scheduling and therefore a sensible reduction in labour costs. The range of Electrolux Blast Chillers crosswise consists of 5 models with built in or remote refrigerating unit that offer an excellent all-round performance.



Model 726622

OPERATING MODES

- Soft Chilling (Air temperature -2°C).
- Hard Chilling (Air temperature -12°C).
- All the probe-driven cycles feature ARTE (Algorithm for Remaining Time Estimation) to make planning the activities easier.
- Holding at +3°C (automatically activated at the end of each cycle).
- Turbo cooling: the chiller works continuously at the desired temperature. Ideal for continuous production.
- Automatic recognition of the insertion of the food probe (cycles piloted either by food probe temperature or by time).

- The control unit provides several operating settings: time/core temperature according to NF and UK regulations, time/air temperature/probe personalised according to national regulations, sterilizing cycle: UV lamps built-in (on request), 3 single sensor or 3-sensor temperature probes (as accessory), ideal for meats, automatic defrosting and manual defrosting. All parameters are programmable.
- Single sensor core probe as standard.
- The control unit provides two large displays to read out: time, core temperature, cycle countdown, alarms, service information.
- Two customizable cycles (P1 & P2) for each operating mode, allowing to set the time and air temperature. These programs can be converted into ice-cream specialized cycles (shape maintenance and holding).

- All information related to the different operating models are recorded: date, time, cycle, core temperature, holding temperature, HACCP accordance.
- An audible alarm starts when the cycle ends or terminates abnormally.

PERFORMANCE

- Chilling times can vary according to food quantity, density, moisture contents and type of containers. Chilling capacity according to NF* regulations is 18 kg.



Electrolux

Electrolux Blast Chillers
Blast Chillers - 28 kg

CONSTRUCTION

- Internal and external finishing in 304 AISI stainless steel and backpanel in galvanized steel.
- High density polyurethane insulation, 60 mm thickness, HCFC free.
- Environmentally friendly: R404a as refrigerant fluid.
- Developed and produced in ISO 9001 and ISO 14001 certified factory.
- Inner cell with fully rounded corners.
- Door equipped with removable magnetic gasket with hygienic design.
- Motors and fan waterproof protected IP20.
- Evaporator with antirust protection.

- Ventilator (fan) swinging hinged panel for access to the evaporator for cleaning.
- Automatic heated door frame.
- Thermostatic expansion valve to optimize the cooling unit efficiency.
- Adjustable feet 150 mm high.
- Stand alone printer as accessory.
- PC connection on request, gate RS 485.

INSTALLATION

- No water connections required.
- Waste water can be plumbed into drain, but can also be collected in an optional waste container.

*NF HYGIENE ALIMENTAIRE certifying authority : AFAQ AFNOR CERTIFICATION. Address:11, Avenue Francis de Pressense - 93571 Saint-Denis La Plaine Cedex - France. Conformity with regulation NF031. Certified guarantees: fitness for cleaning, thermal performance.

	RBC101 726622	RBC101R 726623
TECHNICAL DATA		
Type	C - 28 KG CHILLER	C - 28 KG CHILLER
Productivity per cycle - kg.		
NF Regulations - chilling / freezing	21.6	21.6
UK Guide lines - chilling / freezing	28	28
Gross capacity (D.I.N. 8952) - l.	210	210
Cooling unit	Built-In	Remote
External dimensions - mm		
width	760	760
depth/with open doors	760, 1500	770, 1450
height	1640	1640
N° and type of door	1	1
Door hinges	Right Side	Right Side
Trays type	GN 1/1; 600x400	GN 1/1; 600x400
Max load capacity - trays h 65 mm - n°	6	6
Compressor power - HP	3/4	
N° defrost in 24 hrs.	6	6
Refrigerant type	R134a	R134a
Refrigerant quantity - g.	1530	
Refrigeration power - W	1436	1700
Refrigerant power at evaporation temperature - °C	-5	-5
Power - kW		
installed-electric	1.096	1.096
Net weight - kg.	124	114
INCLUDED ACCESSORIES		
1 SINGLE SENSOR PROBE CHILLER+C/FREEZER	1	1
ACCESSORIES		
1 SINGLE SENSOR PROBE CHILLER+C/FREEZER	880089	880089
2 SINGLE SENSOR PROBES CHILLER+C/FREEZER	880096	880096
3-SENSOR PROBE FOR CHILLER+C/FREEZER	880088	880088
4 WHEELS FOR BLAST CHILLERS	881097	
60 MM PITCH SIDE HANGERS 10X1/1 ELE.OVEN	922121	922121
60 MM PITCH SIDE HANGERS 10X1/1 GAS OVEN	922122	922122
80 MM PITCH SIDE HANGERS 10X1/1 ELE.OVEN	922115	922115
80 MM PITCH SIDE HANGERS 10X1/1 GAS OVEN	922116	922116
KIT 3 SINGLE SENSOR PROBES FOR BC/BCF	880269	880269
KIT HACCP ADVANCED CONNECT. BC/BCF LW+CW	880183	880183
KIT HACCP EKIS	922166	922166
KIT TO CONVERT TO 10X1/1 SLIDE-IN RACK	922201	922201
PAIR OF 1/1 GN AISI 304 S/S GRIDS	921101	921101
PLASTIC COATED GRID-600X400 MM	880864	880864
PRINTER FOR HACCP BASIC VERSION	881532	881532
RILSAN COATED GRID	881061	881061
ROLL-IN RACK SUPPORT BC+BCF 28KG 10GN1/1	881518	881518
TROLLEY FOR 10X1/1 & 2/1 ROLL IN RACK	922128	922128
TROLLEY FOR 10XGN1/1 ROLL IN RACK	922130	922130

HDAA020

2009-10-06

Subject to change without notice

Electrolux Blast Chillers
Blast Chillers - 28 kg

726622

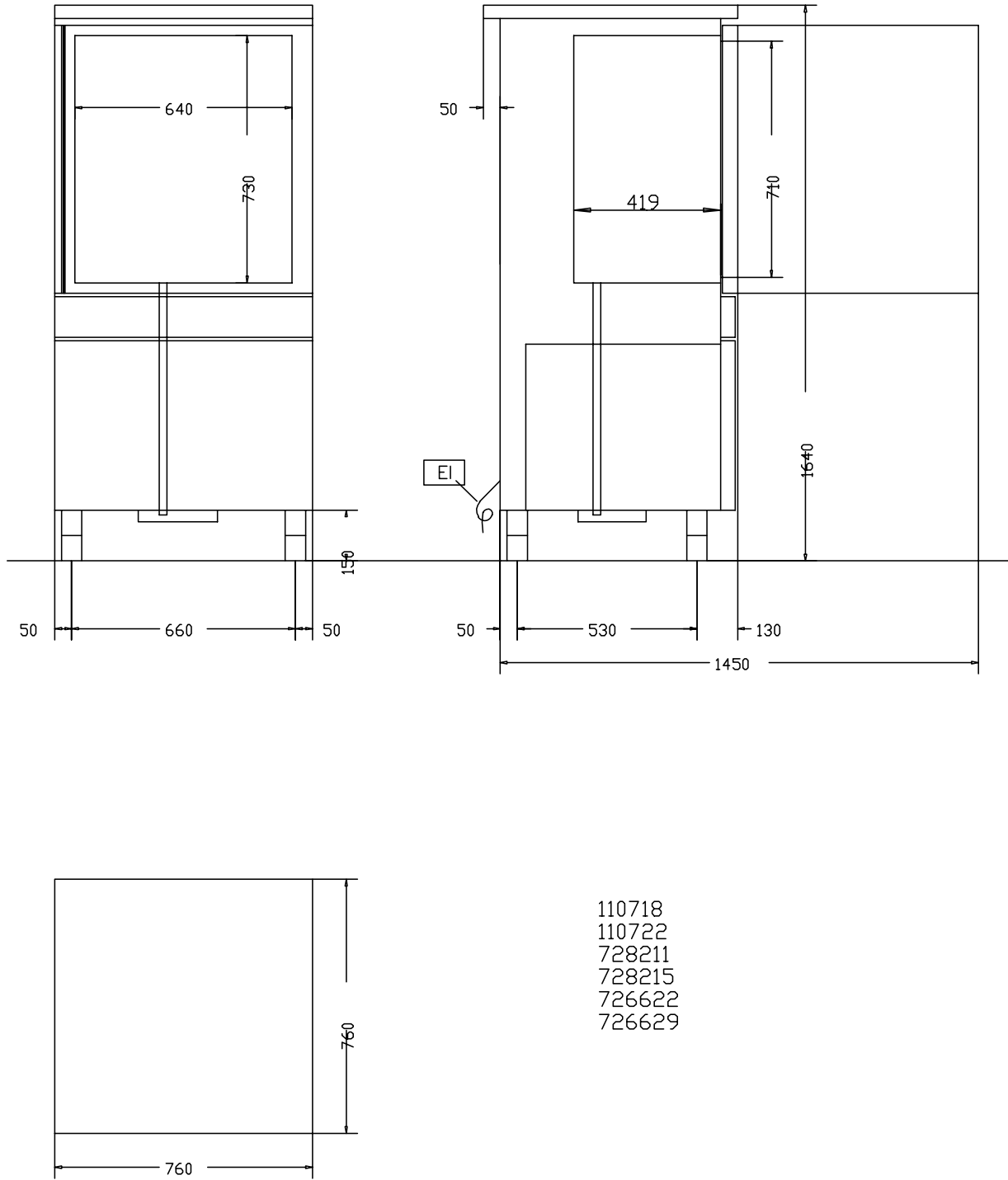

110718
 110722
 728211
 728215
 726622
 726629

LEGEND EI - Electrical connection	RBC101 726622
	230 V, 1N, 50

HDAA020

2009-10-06

Subject to change without notice

Electrolux Blast Chillers
Blast Chillers - 28 kg

726623

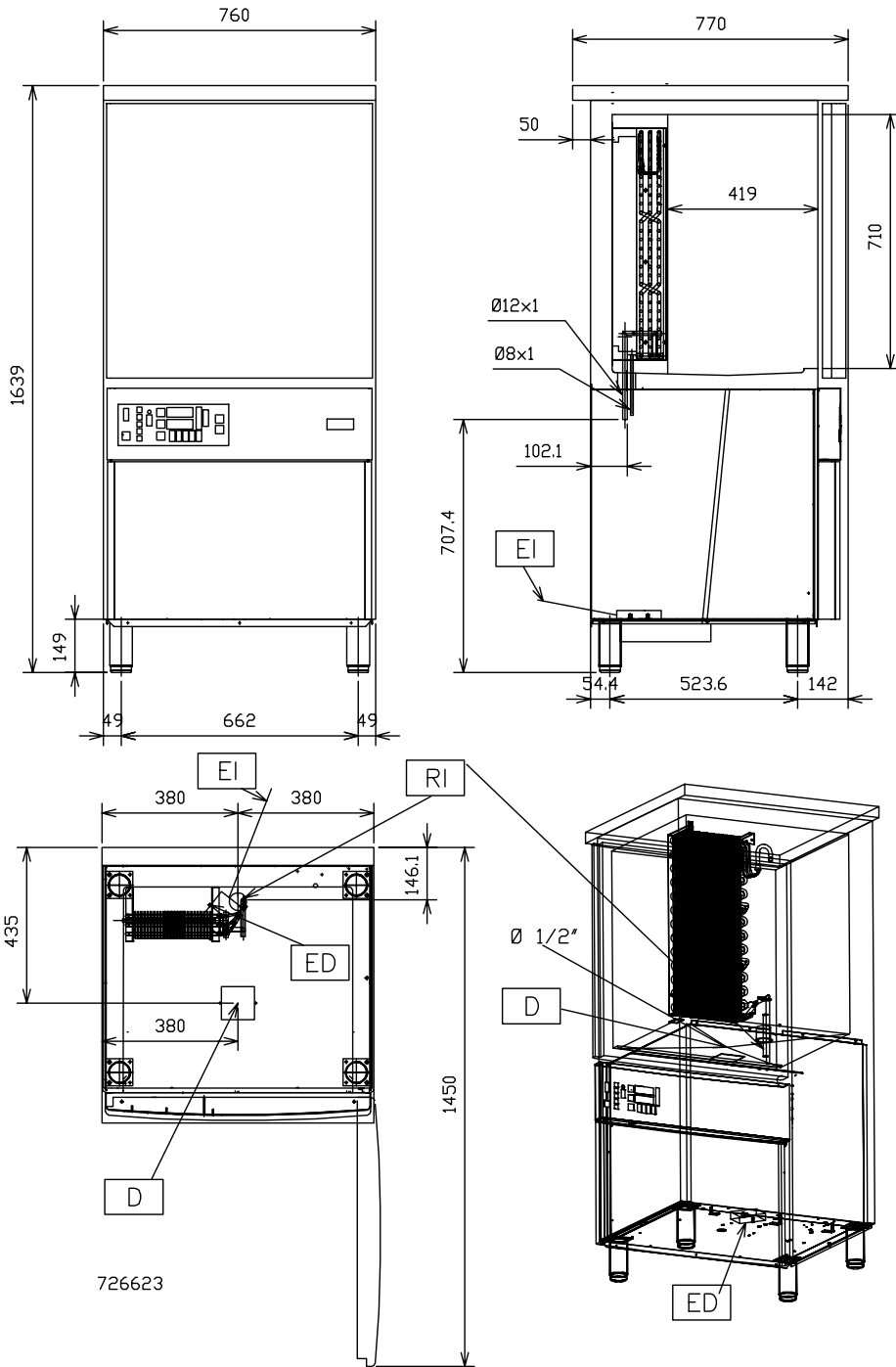

LEGEND D - Water drain ED - Remote electrical connection EI - Electrical connection RI - Remote refrigeration connection	RBC101R 726623
	1/2"
	● 230 V, 1N, 50
	●

HDAA020

2009-10-06

Subject to change without notice