

Administrator's Manual

Software Architecture

CTIO 60 inches CHIRON

CHI60S-2.3



La Serena, January 2011

Contents

Introduction.....	4
Chapter 1: Software general architecture.....	5
Introduction.....	5
1.1 COMMSDEV (Communications Device): SYNCDEV.....	7
1.1.1 Description.....	7
1.1.2 Configuration file.....	7
1.2 GUIDEV (Graphic Unit Interface Device): OPTGUI.....	8
1.2.1 Description.....	8
1.2.2 Configuration file.....	8
1.3 LAMPDEV (Comparison Lamps Device): ECHLAMPDEV.....	10
1.3.1 Description.....	10
1.3.2 Configuration file.....	11
1.3.3 Header Information.....	13
1.3.4 Available commands.....	13
1.4 TCSDEV (Telescope Control System Device): TCSCT60DEV.....	15
1.4.1 Description.....	15
1.4.2 Configuration file.....	15
1.4.3 Header Information.....	16
1.4.4 Available commands.....	16
1.5 Data Handling System Device: DHSDEV.....	19
1.5.1 Description.....	19
1.5.2 Configuration file.....	19
1.6 PAN Device: PANDEV.....	21
1.6.1 Description.....	21
1.6.2 Configuration file.....	21
1.6.3 Available commands.....	22
1.7 ENV (core).....	23
1.7.1 Description.....	23
1.7.2 Configuration file.....	23
1.8 Iodine Cell Device: IODCELLDEV.....	25
1.8.1 Description.....	25
1.8.2 Configuration file.....	25
1.8.3 Header Information.....	26
1.8.4 Available Commands.....	26
1.9 Image Slicer Device: SLICERDEV.....	28
1.9.1 Description.....	28
1.9.2 Configuration file.....	28

1.9.3 Header Information.....	29
1.9.4 Available Commands.....	30
1.10 Focus Device: FOCUSDEV.....	32
1.9.1 Description.....	32
1.9.2 Configuration file.....	32
1.9.3 Header Information.....	33
1.9.4 Available Commands.....	33
Chapter 2: Software Tree / directories.....	36
2.1 Software tree.....	36
2.2 Directories description.....	36
References.....	39
Glossary.....	40

Introduction

The following document is a reference to the CTIO 60 inches CHIRON Software structure. It provides a way of understanding its' internal structure and configuration

This document describes each of the devices present in this application. It also describes the directories structure and where to find binaries and configuration files. This document does not include information on how to handle the GUI (see *CHI60S-1.0*) or commands/scripting (see *CHI60S-3.0*), but just a basic guide to maintenance and a general view of the architecture.

Note that that several of the devices described are identical to those of the old CHIRON at the same telescope (manuals CHI60X-XX)

Chapter 1: Software general architecture

Introduction

The Chiron 60 inches software is based on software modules, called “devices”, that talk to each other using a protocol called “SML”. Each device is in charge of an specific task. Each device is independent on one another, being the SML protocol the only way of “contact” between them. In this way, the software is totally modular. The “core” of the software (called “ENV”) only starts the devices at boot time.

The Chiron software is composed of two separate applications: CHIRTEMP and CHIRON. The first is exclusively in charge of the temperature handling/logging/alarming, etc, while the second is in charge of the operation of the instrument. It was done in this way just so the temperatures are always being run/recorded independent on the fact that the instrument software may be down due to problems or simply because the instrument is not in use. For a description of the CHIRTEMP application, please see document *CHI60S-X-T*

In *Figure 1.1* is shown a general diagram of the software. Each device is represented as a box. The SML protocol is represented as the upper redish line that connects all the boxes (devices) inside each application. Each device was designed for handling a very specific part of the hardware or functionality. The name of each box self-explains the purpose of each device. The “external” clients can talk to the software using raw tcp/ip, allowing easy access to scripts. The software also provides wrappers that encapsulates the tcp/ip, making even easier for the scripts or external clients to access all the functionality. Details on this wrappers is provided in *Chapter 2*, and details on scripting is provided in document in *CHI60S-3.0* (scripting). In the following points we will briefly explain each device and application.

Panview is the application in charge of handling the camera itself (detector controller). It handles the camera. Gets the pixels data and produces a fits file with the detector and camera-related headers. This fits file is taken by the DHSDEV in CHIRON and there the extra headers are appended.

Panview is also a separate application that talks through (and it is talked to) using raw tcp/ip command. Panview is explained in document *CHI60S-6.X*

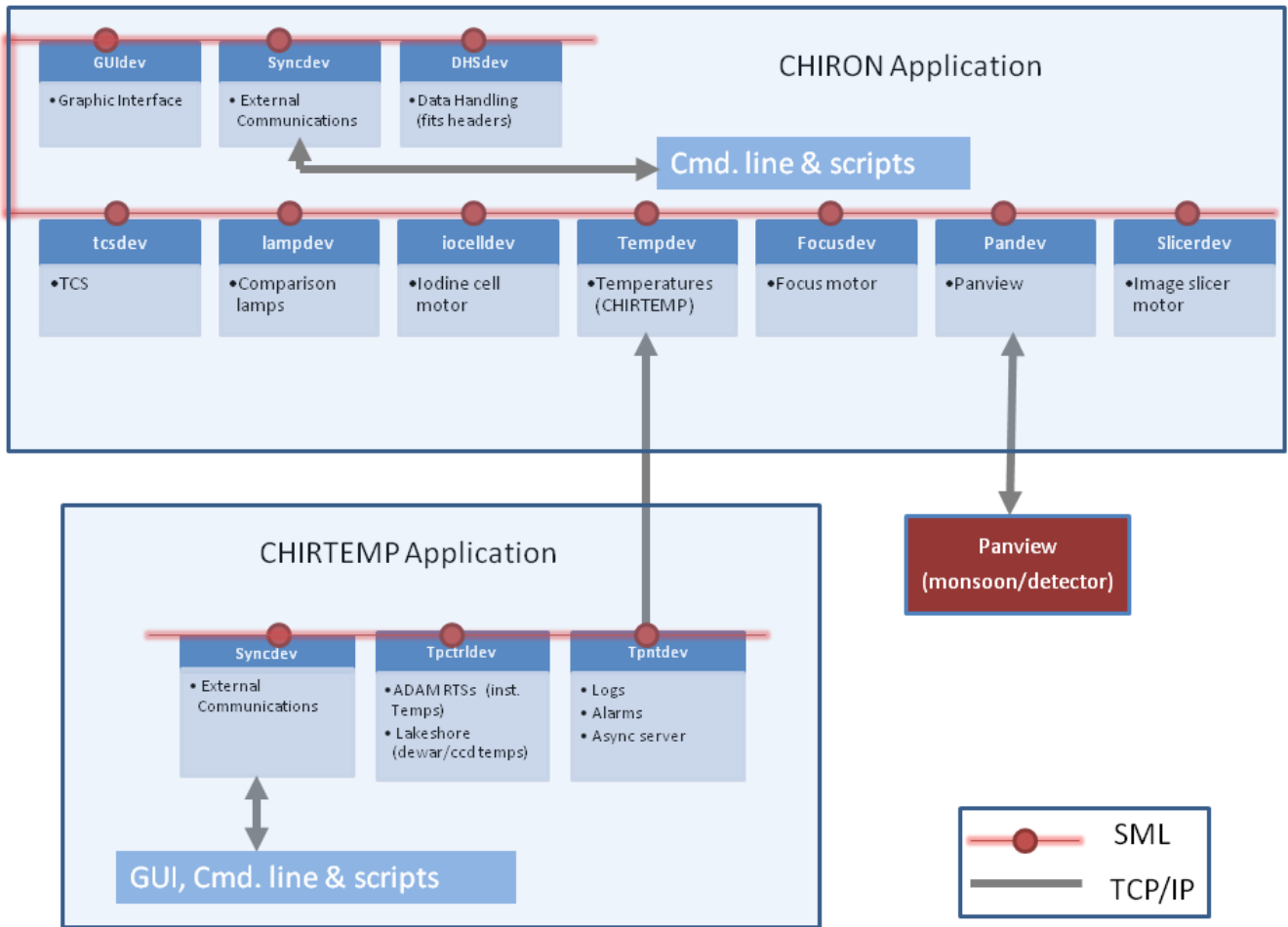

Figure 1.1: software diagram

1.1 COMMSDEV (Communications Device): SYNCDEV

1.1.1 Description

This device's only function is to provide an interface between the “external world” and the SML “bus” (so, the devices themselves). This device has a multiple clients tcp/ip server that allow to receive command and send responses, and also to send asynchronous messages. In general, the communications protocol is based on two channels: a command/response channel, and an asynchronous messages channel. This device, then, receives the command through the tcp/ip channel, and passes that command -using SML- to the appropriate device, passing then the response back from the device (SML) to the client (tcp/ip). It also passes an SML “async” message into a tcp/ip async. Channel.



Figure 1.2: communications device: syncdev

The wrappers provided to easy scripting “hide” all this, giving to the user a single point to handle the software without the need to worry about the protocol details, other than the command and response syntax. See next chapter for examples.

1.1.2 Configuration file

The configuration file is called **DEV_SYNC.cfg** and it is located in the standard application's configuration directory (see next chapter)

```
[COMMS]
port=1920           // tcp multi-client command/response service port
asyncport=1930     // tcp multi-client async. Server port
blockport=1940     // tcp single client blocked port
maxcmdsvr=2       // maximum amount of command/response clients allowed at a time
maxasynsvr=2      // maximum amount of async. Client allowed at a time

[LOG]
log=yes           // enable logging?
file=__LOGPATH/DEV_SYNC.log // file log path. See next chapter for “__LOGPATH” definition
```

1.2 GUIDEV (Graphic Unit Interface Device): OPTGUI

1.2.1 Description

The Graphic Interface itself is the front end of a SML device (a piece of software that is based in the SML protocol/structure). When the user press buttons or type controls, those actions are internally translated into an SML commands (which are, actually, ASCII commands plus some headers) that go to the devices appropriate for the actions requested. The GUI description is outside of the scope of this document. For that description, please see document CHI60S-1.0 (CHIRON GUI User's Manual)

1.2.2 Configuration file

The configuration file is called **DEV_OPTGUI.cfg** (located on the standard application's configuration directory)

```
[MISC]
autopis="" //Plug-Ins to start automatically
beep=TRUE //beep when observation is done
inforate=3000 //rate to display telescope information,in msec

[LOG]
log=true //log?
asyncfile=__LOGPATH/DEV_OPTGUI_async.log //log file path
```

All the entries starting as “TYPE_XXX” means: this is an observation of type XXX. Automatically the GUI will create the appropriate entries in the GUI (observation type drop down menu, controls, etc)

```
[TYPE_Object] //type “Object”
exptime=4.000000 //last typed exposure time, in secs
nimages=1 //last typed number of images
comment=none //last typed comment
title=none //last types image title

[TYPE_Dark] //type “Dark” (shutter will not open)
...

[TYPE_Bias] //type “Bias” (exposure time will be always zero)
...
```

[TYPE_Calibration] //type “calibration” (same as “flat”, selected comparison lamps will
be turned ON

...

Any other (arbitrary) observation type can be added here.

1.3 LAMPDEV (Comparison Lamps Device): ECHLAMPDEV

1.3.1 Description

This device is in charge of handling the comparison lamps. It knows how to talk to the ADAM module in the comparison lamps control box (for details on this hardware implementation, please refer to document *CHI60HF-5.0*).

When the user requests to turn on/off an specific comparison lamp, this device receives a request, and transforms that request into a command that the hardware in the comparison lamps control box understands. Particularly, it gets translated into an **ADAM's 6050** ASCII UDP command

This device implements a set of interlocks to avoid undesired conditions, as having two lamps ON at the same time. As the control box also has “manual” inputs (physical switches in the console), this device also monitors those inputs (also from the **ADAM** module). In the following description we will call the physical switch “manual switch”, and the on/off software command “software switch”.

The implemented logic follows the following rules:

- a) **If a manual switch is detected (digital input), it turns immediately OFF all the software switches.** Since the lamp control signal is an OR between the manual and the software switch, this ensures that only the lamp commanded with the manual switch will be ON. *Figure 1.3 a)* represent this interlock
- b) If the user commands, through a software switch, to turn ON a lamp while a manual switch is active, it will receive an error with an explanatory message (“manual switch is on”)
- c) **If the user commands, through a software switch, to turn ON a lamp, while another software switch is active (not a manual switch), it will turn OFF that lamp, and after that it will turn ON the new commanded lamp.** *Figure 1.3 b)* represents this interlock. The forced signal output “0” when another software command arrives causes the original (old) software command to be turned off (represented in the diagram as the switch at the input; a digital “1” opens the switch, a digital “0” closes it). To interpret the diagram correctly we need to assume that the switches only acts on “edges” (not states), this is, only when detecting a change in state.

The device keeps polling the ADAM module,.

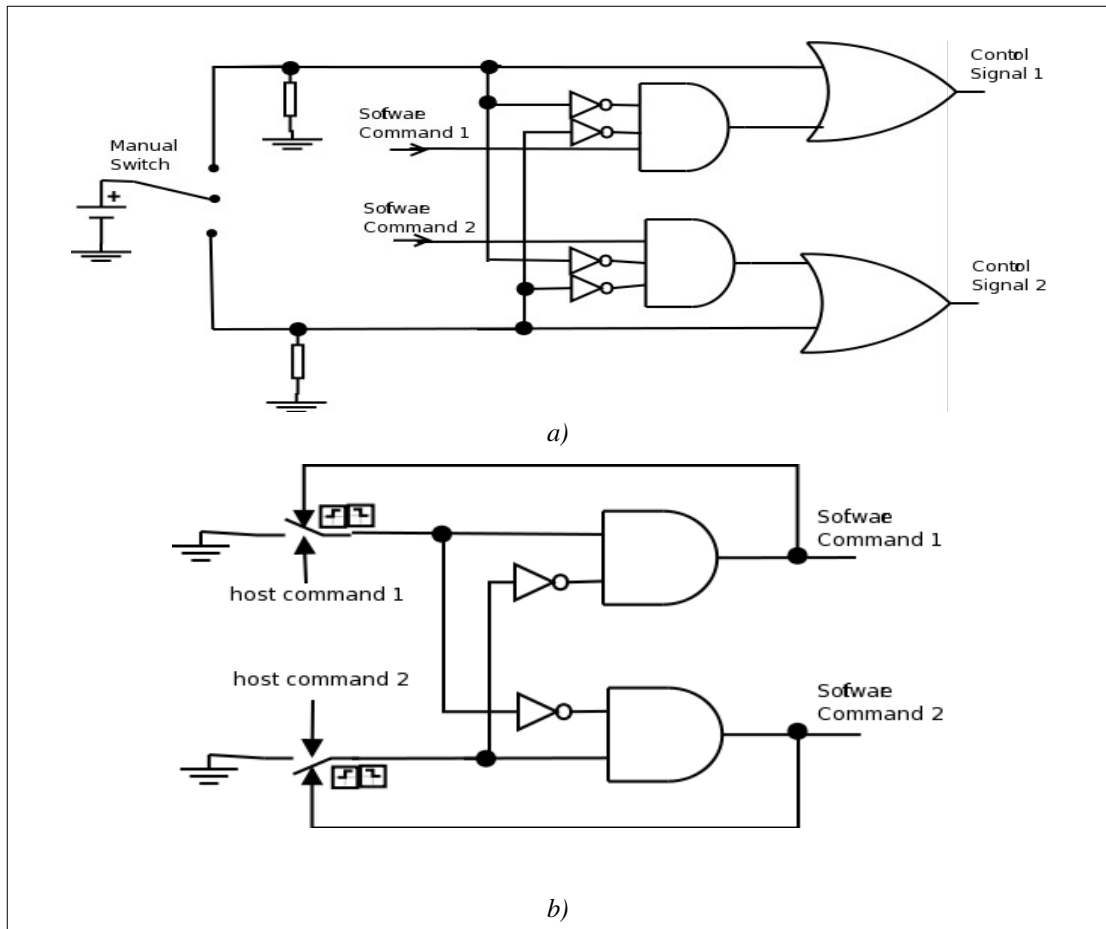

Figure 1.3 a): Manual switch interlock (manual switch always wins), b) Software switch interlock (last command always wins)

The device also implements a timer for the “on” time (after the timer is expired the lamp will be turned off -this, of course, through the software commands, because there is not control over the manual switches-). This is only to avoid the observers leaving the lamps turned on after the observations. This time is a parameter that can be configured through the configuration file.

1.3.2 Configuration file

The configuration file is called DEV_ECHLAMP.cfg, and it is located in the standard configurations directory (see next chapter on software tree). It is based on sections and key/value pairs (as most of the devices configurations)

```

[SETTINGS]
address=139.229.12.49 //ADAM 6050 address
port=1024 //ADAM 6050 UDP service port
updaterate=1000 //polling time, in msec, to ADAM module

```

The rest of the entries describe the actual input/outputs. Each section is a name

```

[TH-AR] // TH-AR lamp
channel=0 // ADAM output channel
inverse=false // implements inverted logic?
timeout=5000 // timeout, in msec, for ON/OFF commands
type=output // ADAM signal type. "output" means "digital output"
maxtimeon=300 // maximum allowed "on" time, in sec

[QUARTZ] // Quartz lamp
channel=2 // ADAM output channel
inverse=false // implements inverted logic?
timeout=5000 // timeout, in msec, for ON/OFF commands
type=output // ADAM signal type. "output" means "digital output"
maxtimeon=300 // maximum allowed "on" time, in sec

[SW_QUARTZ] // manual switch for Quartz lamp
channel=0 // ADAM input channel
timeout=5000 // timeout, in msec, for reading command
type=input // ADAM signal type. "input" means "digital input"

[SW_TH-AR] // manual switch for TH-AR lamp
channel=2 // ADAM input channel
timeout=5000 // timeout, in msec, for reading command
type=input // ADAM signal type. "input" means "digital input"

[MOTOR] // Motor signal
channel=5 // ADAM input channel
timeout=5000 // timeout, in msec, for reading command
type=feedback // ADAM signal type. "feedback" means It is reading back an output

```

The defined input/output for the different lamps and manual switches must correspond to the wired ADAM signals in the comparison lamps control box. For details on this, please refer to document *ECH60HF-5.0* (comparison lamps automation)

1.3.3 Header Information

This device will send to the Data Handling System device (DHSDEV, see *1.5*) the current lamp information every time a change in state is detected (read) in the ADAM module. The header information is 1 line that says

COMPLAMP = ' <lamp_name>' / *comparison lamp*

where <lamp_name> name is the name of the lamp which is ON. If no lamp is ON, “none” will appear.

1.3.4 Available commands

<> indicates an obligatory field

[] indicates an optional field

| separates argument options

Commands are case sensitive.

Prefix: ECHLAMP | LAMP | LAMPS

set <lamp_name> < ON | OFF >

description

turns on/off the specified lamp

return value

DONE or ERROR <error message>

get <lamp_name>

description

gets the state of the specified lamp

return value

DONE or ERROR <error message>

list [-params]

description

Lists the available lamps, one line per lamps (\n separated)

-params: returns additional information for each lamp

return value

On success:

name= <lamp_name> [, channel=<channel_number>, inverse=TRUE | FALSE,
timeout=<command_timeout>, type=<lamp_type>, status=TRUE | FALSE] \n

...

On error:

ERROR <error_message>

status

description

brings information on the device and lamps

return value

On success:

<lamp_name> <ON | OFF> <ON | ERROR <message>>\n

...

On error:

ERROR <error_message>

1.4 TCSDEV (Telescope Control System Device): TCSCT60DEV

1.4.1 Description

The TCS device has in charge the communication / handling of the Telescope Control System (TCS). It can talk to the TCS computer using a serial line or the RPC protocol.

Every time a new image will be taken -detected as an asynchronous message from the PAN device (see *1.6*)-, this device requests information from the TCS (usually “info” command, but this is customizable, see the configuration file description next), and that information gets passed to the Data Handling System Device (see *1.5*). It also keeps polling for info, so when the connection is lost it sends an asynchronous message that the GUI device detects, turning the TCS led red (when the connection is re-acquired the inverse happens, and the GUI TCS led gets turned green)

1.4.2 Configuration file

The configuration file is called **DEV_TCS.cfg**, and is located in the standard config directory of the application.

[Comms]

```
params="type rpc_tcs, address 139.229.12.8" //protocol type (rpc_tcs or serial), tcs address
#params="type serial, port 0, brate 9600" //commented out, in case serial is used
tcsport=1 // TCS service port
retries=2 // retries if failure
```

[Status]

```
updaterate(ms)=2000 // polling rate to TCS, in msec
postasync=false // generate an async. Message with the info
```

[MISC]

```
commands="" // commands at startup
```

[HDRINFO]

```
infofile=TCSCT60_INFO.tpl //info file template (see below)
infocmd="POINTING, INFO, DOME" //command to send for “info”.
```

[LOG]

```
log=true // generate a log file?
file=__LOGPATH/DEV_TCSCT60.log //log file location
```

1.4.3 Header Information

The information that this device exports is taken from a file template. This file template states what information to export from the returned TCS information (returned from the “infocmd” stated in the configuration file. The template is specified in the key “infofile” in the configuration file

The template is a sequence of lines, where each line is

```
KEYNAME = '[(
```

where <value> is the value to assign to that key. The <value> can be a constant or a value from the telescope information, as returned from the “info” device command.

<datatype> can be any supported datatype (FLOAT, I32, U32, I16, U16, I8, U8, STR). If no <datatype> is specified, it is assumed STR

The template is:

```
OBSERVAT='CTIO                ' /Origin of data
TELESCOP='CTIO 1.5 meter telescope ' /Specific system
DATE-OBS  ='date-obs          ' /date of observation start
UT        ='universal_time    ' /UT of TCS coords
RA        ='ra                ' /ra
DEC       ='dec               ' /dec
EPOCH     ='(FLOAT) epoch     ' /epoch
ALT       ='dome_azimuth      ' /altitud
HA        ='hour_angle        ' /ha
ST        ='sidereal_time     ' /sidereal time
ZD        ='zenith_distance   ' /zenith distance
AIRMASS   ='airmass           ' /airmass
```

For example, the field RA = 'ra' ... means that it will take whatever value the field “ra=” has in the returning information (response to command “info”. See available commands next). The result of replacing the stated values is sent to the DHS device

1.4.4 Available commands

<> indicates an obligatory field

[] indicates an optional field

| separates argument options

Commands are case sensitive.

Prefix: TCS | TCSCT60

INFO

description

return current telescope information. At the low level, it sends to the TCS the commands stated under “infocmd” in the configuration file, and concatenate the responses, presenting them as stated below

return value

On success:

Return the telescope information

date= 2009-12-23

universal_time= 17:00:34.0

date-obs= 2009-12-23T17:00:34.0

ra= 12:45:28

dec= 64'36"

epoch= 2000.0

hour_angle= -00:30:16.1

sidereal_time= 05:04:01.1

dome_azimuth= 260.0

airmass= 1.015

zenith_distance= 12.5

slew_ra= 45.000

slew_dec= 45.000

raw_ra= 12:45:28

raw_dec= 64'36"

sidereal_time= 05:04:01.1

raw_ra= 12:45:28

raw_dec= 64'36"

apparent_ra= 12:45:28

apparent_dec= 64'36"

On error:

ERROR <error_message>

OFFSET <RA> <DEC>

description

moves the telescope (offsets) by the specified amount of arcsecs in RA and DEC

response

On success:

OK <time> as immediate response, where <time> is the estimated time for the action, in msec

DONE (TCS:OFFSET) as callback response

On error:

ERROR <error message>

The TCS devices also passes to the TCS itself any other command it receives; this means that any command available in the TCS documentation can be passed straight, and the direct response will be passed back as response (see the 60 inches TCS commands reference)

1.5 Data Handling System Device: DHSDEV

1.5.1 Description

This device is in charge of collecting the data that will be available for the headers and -in some cases- also the pixel data. The other devices will send (write) to it any information to share, and it is this device's responsibility to handle the data so the data becomes available.

This particular DHS implementation connects gets an asynchronous message every time a new fits file is available on disk. Then it takes the fits file, and appends all the header information available from the other devices, according to a header template. The initial (data) fits file is created by the application that handles the camera (Panview, see document **CHI60S-6.X**). See Figure 1.1. The device can also run a script prior and after the image header has been written. In this particular application it is invoking an script before reading the image template and another after the headers have been written. The first script is used to gather the environmental information (weather, seeing), while the second to send the fits image to the automated data archiving pipe (save the bits)

1.5.2 Configuration file

The configuration file is called **DEV_DHS.cfg**, and is located in the standard configuration file of the application.

[DHS]

params=type queue, retries 6

/states how to connect to the dhs: connection type (“**type**”), and retries. Note that the connection type is “queue” indicating that it will connect to a localdhs through a local queue. It could also talk directly to the dhs in panview.

[LDHS]

hdrtemplate=CHIRON.tpl

asyncmsg=true

preproc=\${APPROOT}/CHIRON/bin/envinfo

postproc=/bits/bin/postproc

/points to the header file template that will be used to append the fits header information. The template says what to write, where, and what comment.

The other parameter (asyncmsg) says if the device will generate an async. Message when the image is complete and closed. “postproc” is the script that is called after the image has been processed (headers added). It calls it using as an argument the path to the fits file just finished

“preproc” is the script that is called prior to adding the fits headers. In this case, it is calling the script “envinfo”, which requests the environmental information from a sire database, and dumps it into a file called /tmp/envinfo.txt. This file is then appended to the fits headers by DHS itself-see the fits header template below-.

The template file looks like this:

```
DHSID = 'DHSDEV ' /dhs indentification  
SLICER = 'dev SLICER position ' /slicer position (mm)  
DECKER = 'dev SLICER named_pos ' /decker position name  
FOCUS = 'dev FOCUS position ' /slicer position (mm)  
TEMPS = 'dev DHS 2DARR TEMPDEVINFO ' /temperatures  
LAMPINFO = 'dev DHS 2DARR LAMPINFO' /lamps information  
IODINFO = 'dev DHS 2DARR IODCELLINFO' /iodcell information  
TCSINFO = 'dev DHS 2DARR TCSINFO' /tcs information  
WEATHER = 'file /tmp/envinfo.txt' /enviromental information
```

Note that each device is responsible for the information it shares through its local variable or array. Also note the last entry there, which tells it to append the specified file (which was previously created by the script specified in “preproc” (“envinfo”).

1.6 PAN Device: PANDEV

1.6.1 Description

This device is in charge of handling the pixel generation and all the hardware associated to it. **PAN** stands for Pixel Acquisition Node, A **PAN** is, then, a single point of pixels / headers collections.

This device is designed to handle any arbitrary amount of “PANs”, each “PAN” being in charge of some particular sub-system or detector controller. This, of course, in systems where more than one detector controller is used. In the case of this application there is only one detector controller, so this device handles a single PAN here.

“**Panview**” is a separate program that is in charge of handling the detector controller and the camera. It is its responsibility to talk to the controller and generate the pixels and headers (data) for a single controller -so, panview is a specific implementation of a **PAN** concept-.

In this application, then, the single PAN that PANDEV handles is a single panview (a single panview that handles a monsoon orange controller). PANDEV connects to panview and any request it receives regarding the controller /detector is passed directly to panview,, which is the one that actually processes the command and returns the response. PANDEV will pass back to the caller (other device) the response. The async. Messages that PANDEV receives from panview are also passed back (available to the other devices) .

When there are several panviews, PANDEV is in charge of broadcasting the commands, mixing the data, etc (managing all the panviews together) ; however, in this application, having a single panview, PANDEV appears more like an interface between panview and SML

1.6.2 Configuration file

The configuration file is called **DEV_PAN.cfg** and it is located in the standard application's configuration directory.

```
[_chiron] // name of the panview to connect
startscript=xgterm -e start_panchiron // script to call at startup, to start panview
stopscript=yes // when shutdown, shutdown also panview
type=tcp // type of connection to panview
cmdparams=address localhost, port 5415, retries 6, altport 5615 // command/response parameters
asyncparams=address localhost, port 5435, retries 16, altport 5635 // asynchronous channel parameters
```

All the configuration related to the detector specific information (readmodes, size, geometry, etc) is

handled by panview and it is not part of PANDEV. In other words, it is panview's business how to handle the controller/detector. For information and details on panview's configuration files for this application, please refer to document *CHI60S-6.0* (panview configuration)

1.6.3 Available commands

As the commands are passed to panview, the available commands are all the available panview commands. We will not give a complete list of the available panview commands here (beyond the scope, too many of them). For that refer to document *CHI60S-3.X* on scripting. There is presented a list of the most useful observer-level commands

1.7 ENV (core)

1.7.1 Description

ENV is the core of the application. It does not map to any specific hardware or functionality, but defines what devices will be available and started at software startup time. It also provides a way of talking to all the devices at a time, as for broadcasting a system command (Offline/shutdown, etc. See documentation on SML devices).

1.7.2 Configuration file

The configuration file is where the standard directory for configurations is. This directory is actually defined here. The configuration file is called ENV.cfg, and can be considered the first, or master configuration file

```
[APP]
name=CHIRON           // defines application name
path=./ArcVIEW/      // define path to application (sources) root
[ENVIRONMENT]
MainVisible=False    // show main window?
[TRANSLATIONS]
APP=PAN              // defines translations, or "aliases" to the devices. See below for more details
dhe="PAN DHE"        // if arrives a command that start with "dhe" assumes it is PAN DHE
DHE="PAN DHE"        // etc
FITS="PAN FITS"
fits="PAN FITS"
DISPLAY="PAN DISPLAY"
GRTD="PAN DISPLAY"
TPNT="PAN TPNT"
LAMP=ECHLAMP         //if a command "LAMP" arrives, send it to ECHLAMP device
LAMPS=ECHLAMP
pan=PAN
tcs=TCS
[VAR]                // This defines some "global" variables, that any module can see
__MODPATH=__APPPATH/modules //where the modules (devices) are
__CONFPATH=./        // where the configuration directory is.
__LOGPATH=./log      // where the log directory is.
[DEVICES]           // defines where the devices are
file=ENV_DEVICES.cfg // or the file where the available devices is defined.
```

Note that here is defined the configuration directory as "./", which means "this directory". This means

that where this directory is, all the config files for the other modules will also be. Note also that here it is defined the global variable “__LOGPATH” that all the devices are using to define their log directory. The “translations” entry defines other names that the device can have, meaning that if a command with those names arrives it will be routed to the defined device.

The file that defines what devices are available is here set as ENV_DEVICES.cfg (which is the same as ./ENV_DEVICES.cfg -in the current directory-

In this file each section defines a device. The name of the section is the device's name.

```
[SYNC]                                // device name
Path=__MODPATH/SYNCDEV/public/vis/SYNC_Device.vi // path to the device's main vi (API)
Commands="START; INIT"                //commands to pass at load time
[COMSTCP]
Path=__MODPATH/COMSTCPDEV/public/vis/COMSTCP_Device.vi
Commands="START; INIT"
[PAN]
Path=__MODPATH/PANDEV/public/vis/PAN_Device.vi
Commands="START; INIT"
[DHS]
Path=__MODPATH/DHSDEV/public/vis/DHS_Device.vi
Commands="START; INIT"
[LOG]
Path=__MODPATH/LOGDEV/public/vis/LOG_Device.vi
Commands="START; INIT"
[TCS]
Path=__MODPATH/TCSCT60DEV/public/vis/TCSCT60_Device.vi
Commands="START; INIT"
[ECHLAMP]
Path=__MODPATH/ECHLAMPDEV/public/vis/ECHLAMP_Device.vi
Commands="START; INIT"
[TEMP]
Path=__MODPATH/TEMPDEV/public/vis/TEMP_Device.vi
Commands="START; INIT"
[OPTGUI]
Path=__MODPATH/GUI/OPTGUI/public/vis/OPTGUI_Device.vi
Commands="START; INIT"
```

Note that __MODPATH was defined in ENV.cfg. The command “START” means “load the device”. The command “INIT” means “initialize” it. What each device does on initialization depends on the device.

1.8 Iodine Cell Device: IODCELLDEV

1.8.1 Description

The Iodine Cell device is the software component that takes care of handling the ADAM module that handles the iodine cell motor (in/out). This device talks to the ADAM 6050 located on the RTD/Data IO box (see document **ECH60HF-7.X**). It basically polls for the status of the module, and request changing the status (true/false) of the output that goes to the motor driver. The configuration file

1.8.2 Configuration file

The configuration file is called DEV_IODCELL.cfg, and it is located in the standard configurations directory (see next chapter on software tree). It is based on sections and key/value pairs (as most of the devices configurations)

This file describes what inputs and outputs of the ADAM will be used, and also the address/port of the ADAM module

[SETTINGS]

address=139.229.12.32

port=1024

updaterate=2000

Specifies the ethernet address and udp service port of the ADAM module. The updaterate specifies the polling rate in msec

[IODINE]

channel=0

inverse=false

timeout=5000

type=output

movetime=3000

park=last

Specifies the name (IODINE) and the ADAM module output (type=output) channel to use (channel=0). This means that this is set to be DO0 (Digital Output 0). It also states that the output will not be inverted (0/1 polarity), the timeout for the command to be 5 seconds (timeout=5000) and the estimated time for the motor to reach its final position to be 3 secs (movetime=3000). Important, there is no

encoder or home switch, which means that the software sends the “move” command and waits the specified time (movetime), assuming that after that the motor is in position. If the motor gets stucked, or gets disengaged from the actual mechanical arm, the software will not know.

[SW_IODINE]

channel=0

timeout=5000

type=input

Specifies the location of the manual switch in the front panel to be Digital Input 0 (DI0)(type=input, channel=0), and the timeout 5 secs (timeout=5000).

Note that internally the ADAM module does an OR between the Digital Output 0 (DO0) and the Digital Input 0 (DI0) and place the result to Digital Output 1 (DI1). This is the actual control signal applied to the motor driver

1.8.3 Header Information

This device will send to the Data Handling System device (DHSDEV, see **1.5**) the current iodine cell position information every time a change in state is detected (read) in the ADAM module. The header information is 1 line that says

IODCELL = ' <IN | OUT>' / iodine cell position

where IN means “inside light path” and OUT means “out of light path”

1.8.4 Available Commands

<> indicates an obligatory field

[] indicates an optional field

| separates argument options

Commands are case sensitive.

Prefix: IODCELL | CELL

set IODINE < IN | OUT>

description

puts the iodine cell in or out of the light path (moves the motor in or out)

return value

DONE or ERROR <error message>

get <name>

description

gets the state of the specified field. <name> can be IODINE or SW_IODINE (manual switch)

return value

[IN | OUT] , or ERROR <error message>

list [-params]

description

Lists the available fields, one line per each one (\n separated)

-params: returns additional information for each field (iodine or manual switch)

return value

On success:

name= <IODINE | SW_IODINE> [, channel=<channel_number>, timeout=<command_timeout>,
type=<input | output>, status=TRUE | FALSE] \n

...

On error:

ERROR <error_message>

status

description

brings information on the device and fields (iodine cell and manual switch)

return value

On success:

<field_name> <IN | OUT> <OK | ERROR <message>>\n

...

On error:

ERROR <error_message>

1.9 Image Slicer Device: SLICERDEV

1.9.1 Description

The Image Slicer device is the software component that takes care of handling the Image Slicer motor stage. This device talks to the slicer driver in the Motor Control Box (see document CHI60HF-1.X). The motor control box has the driver that handles the actual motor (position, homing, etc). The slicer motor is a PI high precision stage described in more detail in the Motor Control Box description document.

1.9.2 Configuration file

The configuration file is called DEV_SLICER.cfg, and it is located in the standard configurations directory (see next chapter on software tree). It is based on sections and key/value pairs (as most of the devices configurations)

This file describes how to talk to the Motor Control Box and various important parameters on the motor handling.

[COMMS]

params=type tcp, address 139.229.3.237, port 10001
motorID=1

Indicates that it will talk to the Motor Control box using tcp/ip, at the specified port. This is the address of the Lantronix Terminal Server that is physically connected to the Motor Control Box. The port number indicates the serial connection port 1 (10000 + port). The motorID should always be 1 (represents the address of the motor driver in the RS485 bus)

[LOG]

file=__LOGPATH/DEV_SLICER.log
log=true

Indicates where to write the log file.

[CONVERSIONS]

mm2ticks=145636

Indicates the conversion ration between counts (motor encoder ticks) and linear mm (multiply to go from

mm to encoder ticks), so the user can specify the position in mm.

[MISC]

inisp**eed=0.5**

maxs**peed=1.37**

maxp**os=5**

works**peed=1.2**

initt**imeout=35000**

toler**ance=0.001**

These are various parameters for the operation:

inisp**eed**: speed at which the homing is done (mm/s)

maxs**peed**: maximum allowed speed (mm/s)

maxp**os**: maximum allowed position (mm). This should always be 5 mm for the slicer stage.

works**peed**: normal operation speed (mm/s)

initt**imeout**: maximum time allowed when homing (s)

toler**ance**: tolerance to consider that the motor has reached position (mm, absolute)

[PREDEFPOS]

slic**er=0.39**

fib**er=1.5**

slit**=3.87**

narrow_slit**=4.79**

These are predefined positions (in mm), that can be invoked in a move command by, instead of specifying the position in mm, using the predefined name. See Available commands (1.9)

1.9.3 Header Information

This device will send to the Data Handling System device (DHSDEV, see 1.5) the current motor stage position information every time a movement is requested or a “read position” command is issued. The header information is line that says

SLICER = ' (FLOAT) <pos>' / *image slicer position (mm)*

where <pos> is the actual position of the stage in mm, counted from HOME, which is at position 0 -one extreme of the motor stage-

The device also stores in the Database the variable “named_pos” containing the name of the position. If the current position does not corresponds to any predefined position, then the variable will say “none”. The DHS device may use this to be added in the headers.

1.9.4 Available Commands

<> indicates an obligatory field

[] indicates an optional field

| separates argument options

Commands are case sensitive.

Prefix: SLICER

INIT

description

Connects the module to the hardware (Motor Control Box driver) and resynchronizes the last position (stored on disk) to the encoder and servo positions of the driver. It does not moves the motor, but due to the resynchronization is “resumes” from the last position even if the hardware had been unpowered. Note that this will not work if the motor has been moved manually between cycles.

return value

DONE or ERROR <error message>

HOME

description

Starts a homing cycle of the motor. The HOME of the stage is on one extreme of the motor (Limit). When the home is reached the encoder is set to 0 (so only positive positions are allowed)

return value

DONE or ERROR <error message>

MOVE [offset] <mm | name> [-raw]

description

Moves the slicer motor to the specified position. The position parameter can be specified in mm, using a predefined name (that must be defined in the configuration file) or even in encoder ticks if the switch “-raw” is specified (not recommended). Note that the home position is 0, so negative positions are not

allowed. If the parameter “offset” is specified, then the value (in mm) is interpreted as an offset to the current position. Only in this case a negative value will be accepted.

return value

DONE or ERROR <error message>

example

MOVE 3.2 /*will move the slicer stage to 3.2 mm*/

MOVE fiber /*will move the slicer stage to the predefined “fiber” position (for example, 1.5 mm)

MOVE 22400 -raw /*will move the slicer stage to 22400 encoder ticks*/

MOVE offset 1.1 /*will move the slicer stage to 1.1 mm more than the current position*/

set | write <param> <value>

description

sets the specified parameter. Params can be (see configuration file description for parameter description):

<workspeed>, <tolerance>, <inittimeout>, <initspeed>, <maxpos>, <acceleration>, <maxspeed>

return value

DONE or ERROR <error message>

get <parameter>

description

gets the value of the specified parameter. Parameter can be any of the ones described in “set”, and besides:

<position>: gets from the internal register the last position read from the hardware

<velocity>: gets from the internal register the last velocity read from the hardware

return value

<value> , or ERROR <error message>

read <parameter> [unit]

description

reads from the hardware the value of the specified parameter. Parameter can be:

<position>: reads from the hardware the current stage position (mm)

<velocity>: reads from the hardware the current velocity (mm/s)

<acceleration>: reads from the hardware the current acceleration (mm/s²)

[unit] can be “mm” (default) or “ticks” (encoder counts)

return value

<value> , or ERROR <error message>

1.10 Focus Device: FOCUSDEV

1.9.1 Description

The Focus device is the software component that takes care of handling the Focus motor stage. This device talks to the focus driver in the Motor Control Box (see document CHI60HF-1.X). The motor control box has the driver that handles the actual motor (position, homing, etc). The focus motor is a PI high precision stage described in more detail in the Motor Control Box description document.

1.9.2 Configuration file

The configuration file is called DEV_FOCUS.cfg, and it is located in the standard configurations directory (see next chapter on software tree). It is based on sections and key/value pairs (as most of the devices configurations)

This file describes how to talk to the Motor Control Box and various important parameters on the motor handling.

[COMMS]

params=type tcp, address 139.229.3.237, port 10003

motorID=1

Indicates that it will talk to the Motor Control box using tcp/ip, at the specified port. This is the address of the Lantronix Terminal Server that is physically connected to the Motor Control Box. The port number indicates the serial connection port 1 (10000 + port). The motorID should always be 1 (represents the address of the motor driver in the RS485 bus)

[LOG]

file=__LOGPATH/DEV_FOCUS.log

log=true

Indicates where to write the log file.

[CONVERSIONS]

mm2ticks=10000

Indicates the conversion ration between counts (motor encoder ticks) and linear mm (multiply to go from mm to encoder ticks), so the user can specify the position in mm.

[MISC]

*inisp*eed=0.8

*maxs*peed=1.37

*maxp*os=25

*works*peed=1.2

*initt*imeout=35000

*toler*ance=0.001

These are various parameters for the operation:

*inisp*eed: speed at which the homing is done (mm/s)

*maxs*peed: maximum allowed speed (mm/s)

*maxp*os: maximum allowed position (mm). This should always be 25 mm for the Focus stage

*works*peed: normal operation speed (mm/s)

*initt*imeout: maximum time allowed when homing (s)

*toler*ance: tolerance to consider that the motor has reached position (mm, absolute)

1.9.3 Header Information

This device will send to the Data Handling System device (DHSDEV, see **1.5**) the current motor stage position information every time a movement is requested or a “read position” command is issued. The header information is 1 line that says

FOCUS = '(FLOAT) <pos>' / *focus position (mm)*

where <pos> is the actual position of the stage in mm, counted from HOME, which is at position 0 -one extreme of the motor stage-

1.9.4 Available Commands

<> indicates an obligatory field

[] indicates an optional field

| separates argument options

Commands are case sensitive.

Prefix: FOCUS

INIT

description

Connects the module to the hardware (Motor Control Box driver) and resynchronizes the last position (stored on disk) to the encoder and servo positions of the driver. It does not moves the motor, but due to the resynchronization is “resumes” from the last position even if the hardware had been unpowered. Note that this will not work if the motor has been moved manually between cycles.

return value

DONE or ERROR <error message>

HOME

description

Starts a homing cycle of the motor. The HOME of the stage is on one extreme of the motor (Limit). When the home is reached the encoder is set to 0 (so only positive positions are allowed)

return value

DONE or ERROR <error message>

MOVE [offset] <mm> [-raw]

description

Moves the focus motor to the specified position. The position parameter can be specified in mm or in encoder ticks if the switch “-raw” is specified (not recommended). Note that the home position is 0, so negative positions are not allowed. If the parameter “offset” is specified, then the value (in mm) is interpreted as an offset to the current position. Only in this case a negative value will be accepted.

return value

DONE or ERROR <error message>

set | write <param> <value>

description

sets the specified paramete. Params can be (see configuration file description for parameter description): <workspeed>, <tolerance>, <inittimeout>, <initspeed>, <maxpos>, <acceleration>, <maxspeed>

return value

DONE or ERROR <error message>

get <parameter>description

gets the value of the specified parameter. Parameter can be any of the ones described in “set”, and besides:

<position>: gets from the internal register the last position read from the hardware

<velocity>: gets from the internal register the last velocity read from the hardware

return value

<value> , or ERROR <error message>

read <parameter> [unit]description

reads from the hardware the value of the specified parameter. Parameter can be:

<position>: reads from the hardware the current stage position (mm)

<velocity>: reads from the hardware the current velocity (mm/s)

<acceleration>: reads from the hardware the current acceleration (mm/s²)

[unit] can be “mm” (default) or “ticks” (encoder counts)

return value

<value> , or ERROR <error message>

Chapter 2: Software Tree / directories

Here we will give a view of the locations of the different software components and configuration files

2.1 Software tree

Figure 2.1 shows a diagram of the software tree structure

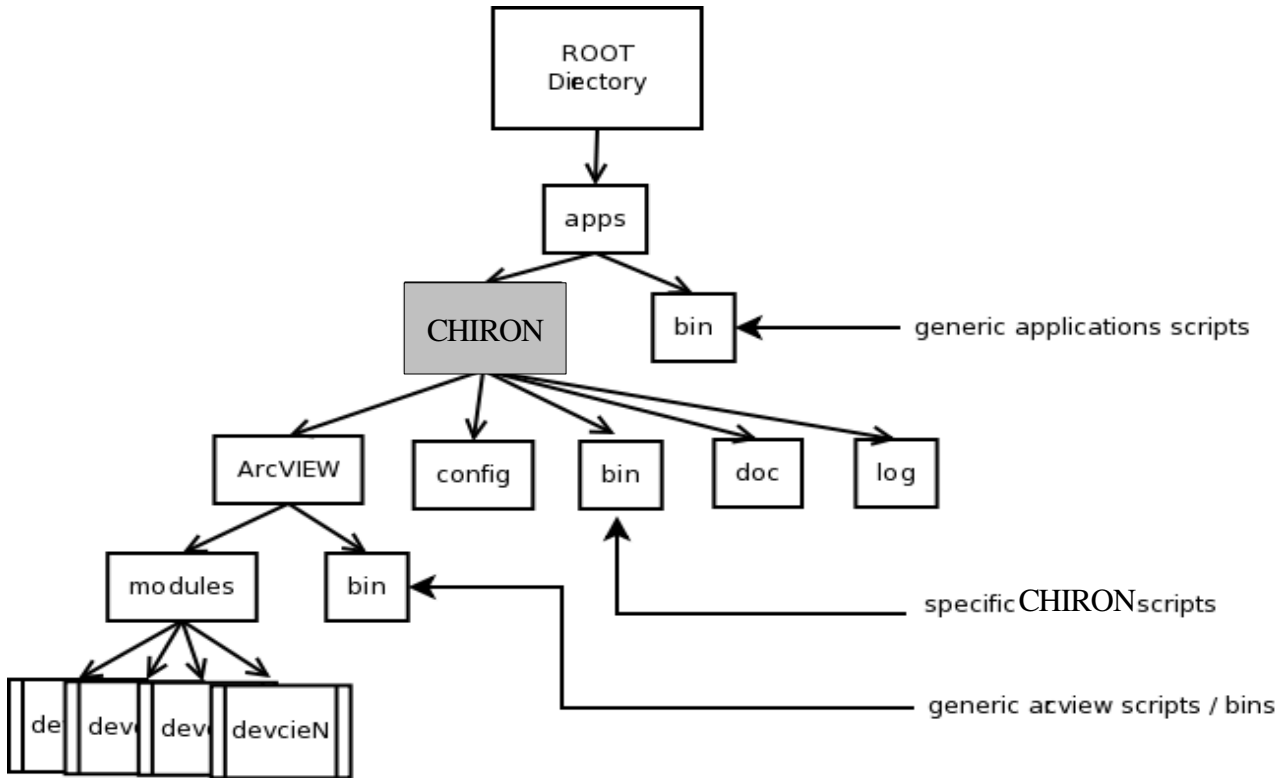

Figure 2.1: Software tree

ROOT directory can be anything. In the case of this application, it is the home directory of the observer's account, `/home/observer/`

2.2 Directories description

apps is the directory where all the applications are. If more than one instrument is in use with the same computer, here it would appear in parallel to the specific CHIRON application

-> **bin**: location of “generic” application scripts. The most important are:

- *start_application <name>*: starts the named application (“start_application CHIRON”)
- *shutdown_application <name>*: shutdown any application (“shutdown_application CHIRON”)
- *CHIRON*: this is a wrapper *created at boot time* to talk to the CHIRON application from a command line. See the scripting reference document (*CHI60S-3.X*) (“CHIRON LAMP set QUARTZ ON”)

-> **CHIRON**: directory of specific CHIRON application

- **ArcVIEW**: directory where sources are
 - modules: all devices sources, one directory per device
 - bin: generic arcview scripts (startup and shutdown, etc)
- doc: specific CHIRON application documentation
- log: all log files of devices (__LOGPATH)
- bin: specific CHIRON application scripts:
 - *start_CHIRON*: starts CHIRON application. This is a “start_application CHIRON” plus some process checking, polling, etc. This is the script actually used to start the application (see *CHI60S-1.X*)
 - *shutdown_CHIRON*: shutdown chiron application. This is a “shutdown_application CHIRON” plus some process checking, poling, etc. This is the script actually used to shutdown the application (see *CHI60S-1.X*)
 - sendsockcmd: binary (executable) that is used by the wrappers to talk to the application (opens a socket, sends the command, prints the response, closes the socket).
 - All the predefined geometry scripts are here. These “geometry” scripts can be invoked from the main GUI to reconfigure the instrument in specific ways. It is possible to add new configurations by just creating new “geom_XX” scripts. The current (default) scripts are specified in the following table

name	Iodine cell	Slicer stage	speed	binning	roi
Fiber	OUT	fiber	slow	8x8	full
Iodine	IN	slicer	fast	3x1	TBD
Normal	OUT	slicer	slow	3x1	full
Slit	OUT	slit	fast	3x1	full

Narrow_slit	OUT	narrow_slit	fast	3x1	full
-------------	-----	-------------	------	-----	------

The name of every script is geom_<name> where <name> is the name in the table above.

- **config**: this is the directory where all the device's configuration files are: DEV_PAN.cfg, DEV_ECHLAMP.cfg, DEV_TCSCT60.cfg, DEV_OPTGUI.cfg, ENV.cfg, etc

In general, the user (observer) should not edit any of this. The administrator (maintenance) should be aware mostly of the configuration directory (apps/CHIRON/config) and the specific CHIRON binaries (apps/CHIRON/bin)

The wrapper CHIRON, in apps/bin, provides an easy way of interacting with the application using simple command line (and hence, scripting). This is a simple csh built at boot time, that calls the binary “sendsockcmd” to open the communications channel (socket) and get the response. Example:

```
CHIRON LAMP QUARTZ ON
```

Will open a socket to the application, send the command “LAMP QUARTZ ON”, wait for the response and print it. In this way, using this as part of a bigger script is very easy. All the details in can be found on the scripting reference document *CHI60S-3.0*

References

- SML documentation
- TCS 60 inches documentation / command list

Glossary

Device:

A software component that encapsulates a specific functionality. It must have a very standard and well-defined internal structure and inputs/outputs, so they can be “plugged” into any application that uses devices

SML:

A communications protocol used by the devices to talk to each other. This is a simple protocol that sends ASCII commands and headers. The protocol makes it transparent if the application's devices are in the same machine or distributed among several ones.