

POWER CORE

USER'S MANUAL

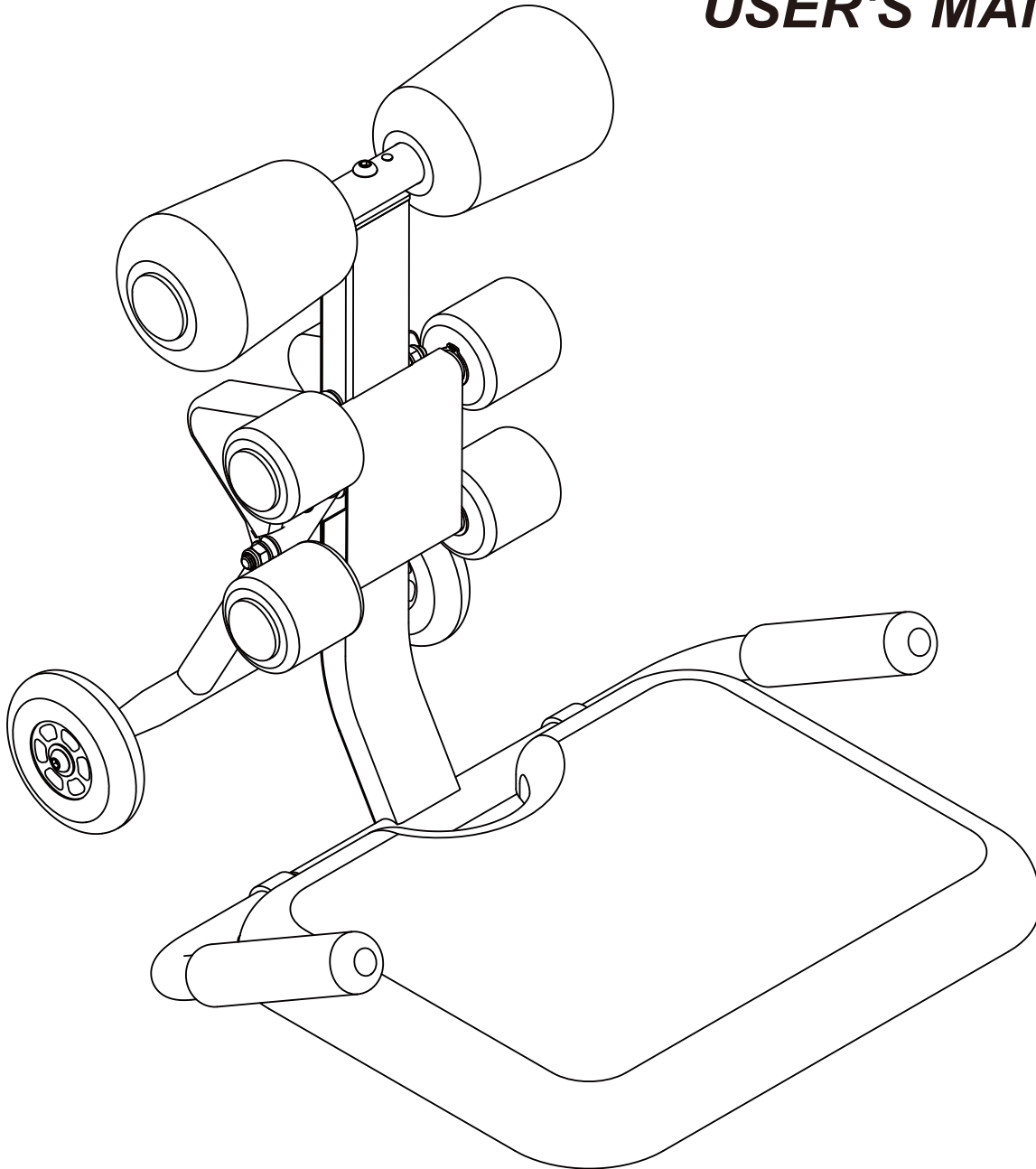

⚠ CAUTION

Read all precautions and instructions in this manual before using this equipment. Save this manual for future reference.

IMPORTANT PRECAUTIONS

WARNING: *To reduce the risk of injury to persons, read the following important precautions and information before operating the Power Core.*

- 1. Before your starting to exercise, read the manual carefully and also always keep this manual with you.*
- 2. Before beginning any exercise program you should consult your doctor first to determine if you have any medical or physical conditions that could put your health and safety at risk or prevent any damage. Your doctor's advise is essential if you are taking medication that affects your heart rate, blood pressure or cholesterol level.*
- 3. Be aware of your body's signals. Incorrect or excessive exercise can damage your health. If you feel dizziness, nausea, chest pain, back pain or other health symptoms stop the workout at once and consult your doctor before continuing.*
- 4. Do not operate any exercise equipment if it is not assembled well. Also you must inspect your machine periodically to ensure your machine in good condition. It is your responsibility to ensure that all users of the equipment are informed of all warnings and precautions.*
- 5. Keep children and pets away from the equipment. The equipment is designed for adult use only. The equipment is not suitable for therapeutic use.*
- 6. Before using the machine, please check the nuts and bolts are securely tightened.*
- 7. Always use the equipment as mentioned. If any defective components while assembling or checking the equipment has been found, or you hear any unusual noises from the equipment during use, stop immediately. Do not use the equipment until the problem has been rectified.*
- 8. Wear appropriate workout clothing while exercising. Do not wear robes or other clothing that could become caught in the machine. Running or aerobic shoes are also required while using the machine.*
- 9. Use the equipment on a flat level, clear surface. Do not use the machine near the water or outdoors.*
- 10. Keep hands away from all moving parts. While lifting or moving the equipment, always do it carefully.*
- 11. The equipment has been designed to comply En957 under class H.C. for home use only.
Maximum weight of user: 110kg/250Lbs.*

WARNING: *Before beginning this or any exercise program, consult your physician. This is especially important for persons over the age of 35 or persons with pre-existing health problems. Read all instructions before using.*

SAVE THESE INSTRUCTIONS

BEFORE YOU BEGIN

Thank you for selecting the revolutionary Power Core Trainer. The Power Core Trainer offers an impressive array of features to make your home workouts more enjoyable and effective. For your benefit, read this manual carefully before using the Power Core Trainer. If you have additional questions, please call our Customer Service Department To help us assist you, please note the product

model number and serial number before calling. The model number of the Power Core Trainer. The serial number can be found on a decal attached to the Power Core Trainer. Before reading further, please familiarize yourself with the parts that are labeled in the drawing below.

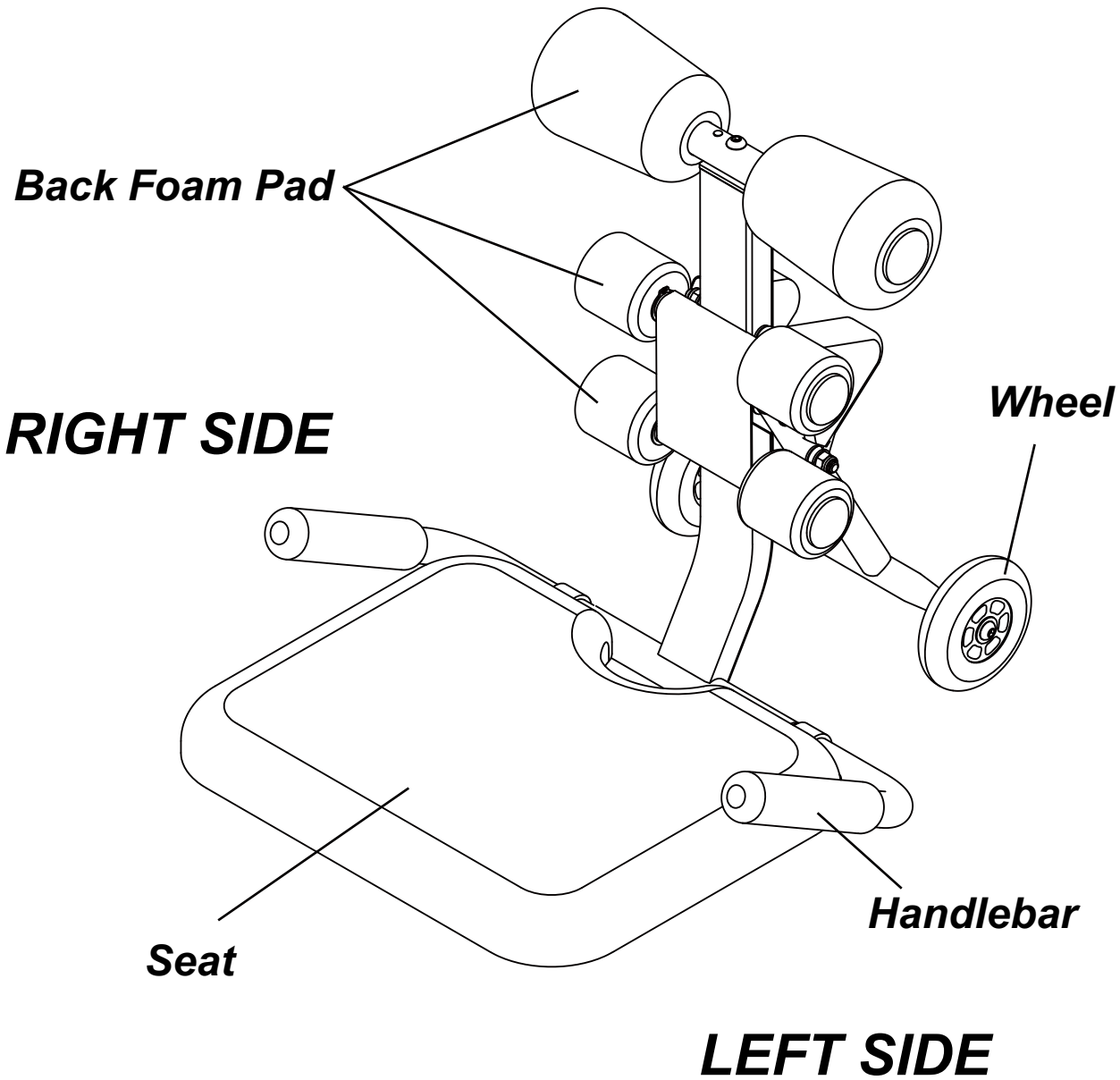

ASSEMBLY

Set the parts in a cleared area and remove all packing materials. Do not dispose of the packing materials until assembly is completed.

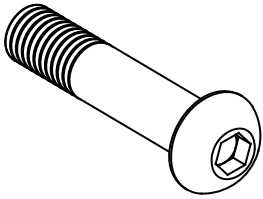

M8 x 45mm Screw

X 1 pcs

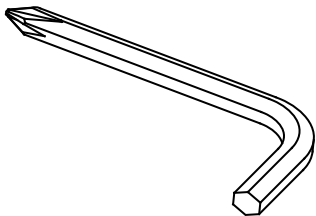

**6mm Allen wrench
and Cross driver**

X 1 pcs

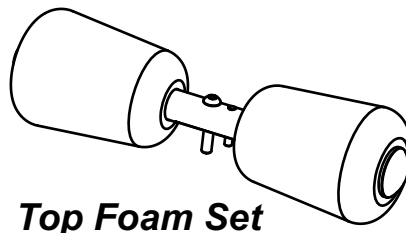

Top Foam Set

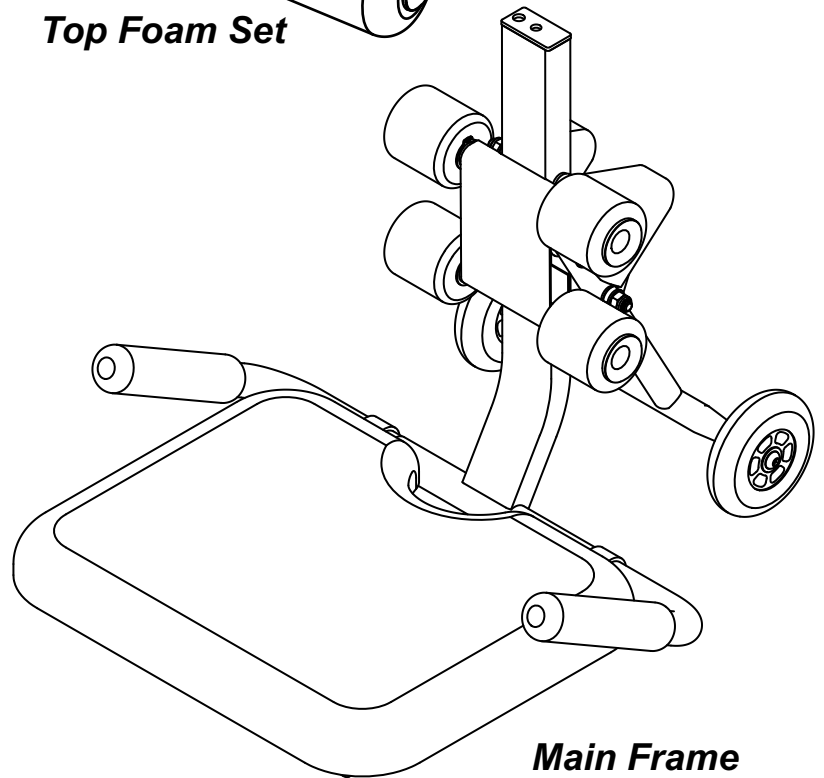

Main Frame

Unpacking your Power Core Trainer where will be using it. Being careful Not to damage . Place your Power Core Trainer on a level flat surface. It is recommended that you place a protective covering on your floor.

Set up the Top Foam set to the corresponding position on the Main Frame.

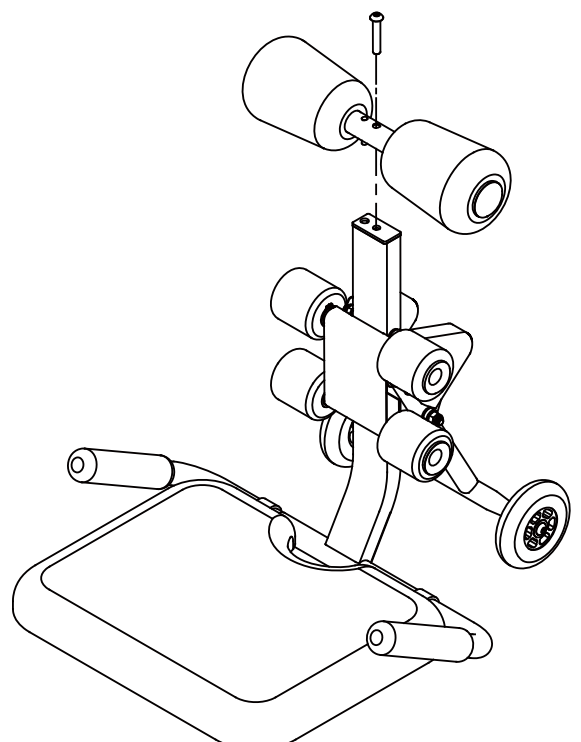

**Then assemble the Top Foam Set properly by bolt.
(Do not tight up too much to make Top Foam Set
can move slightly)**

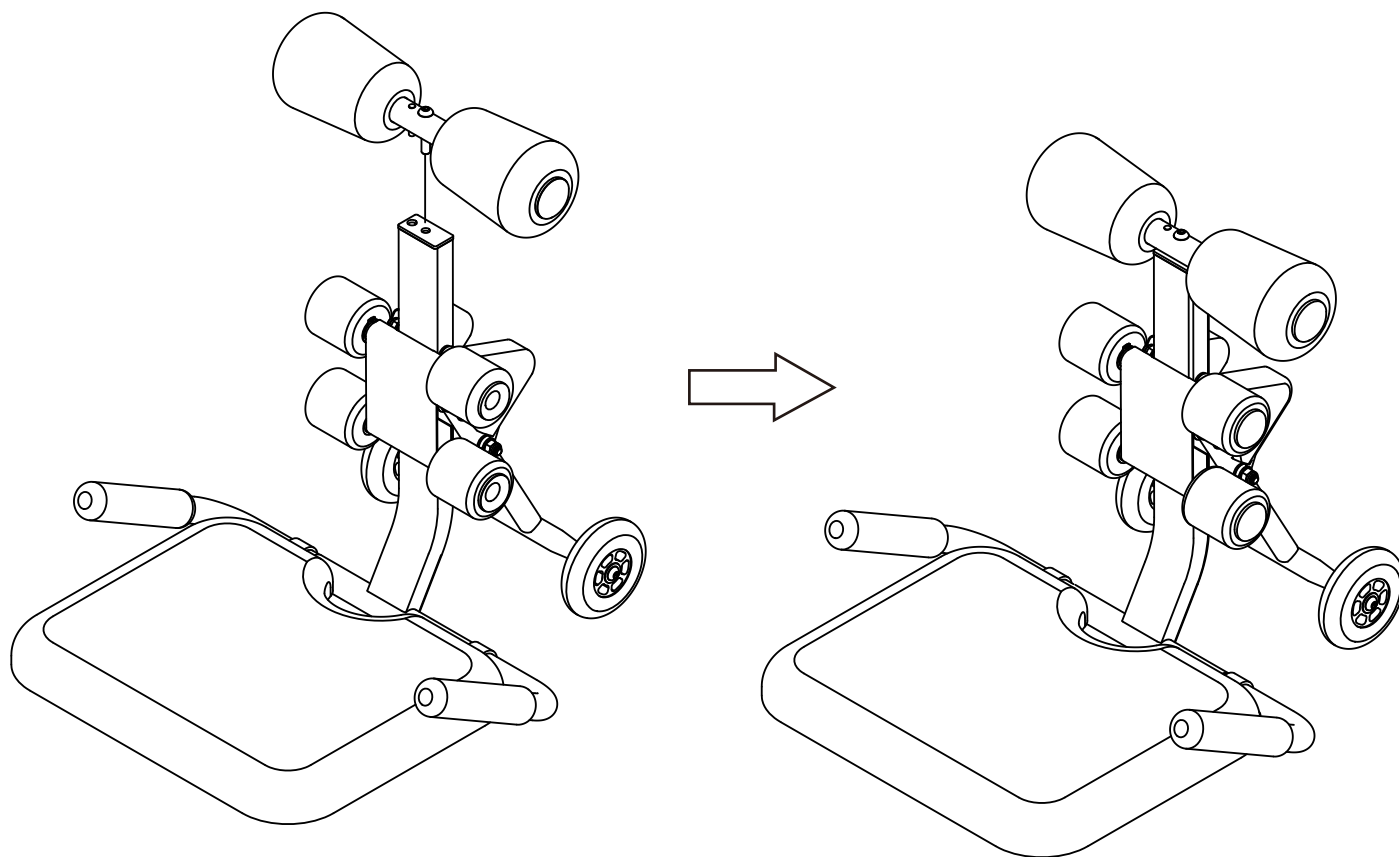

This product is foldable for easy storage.

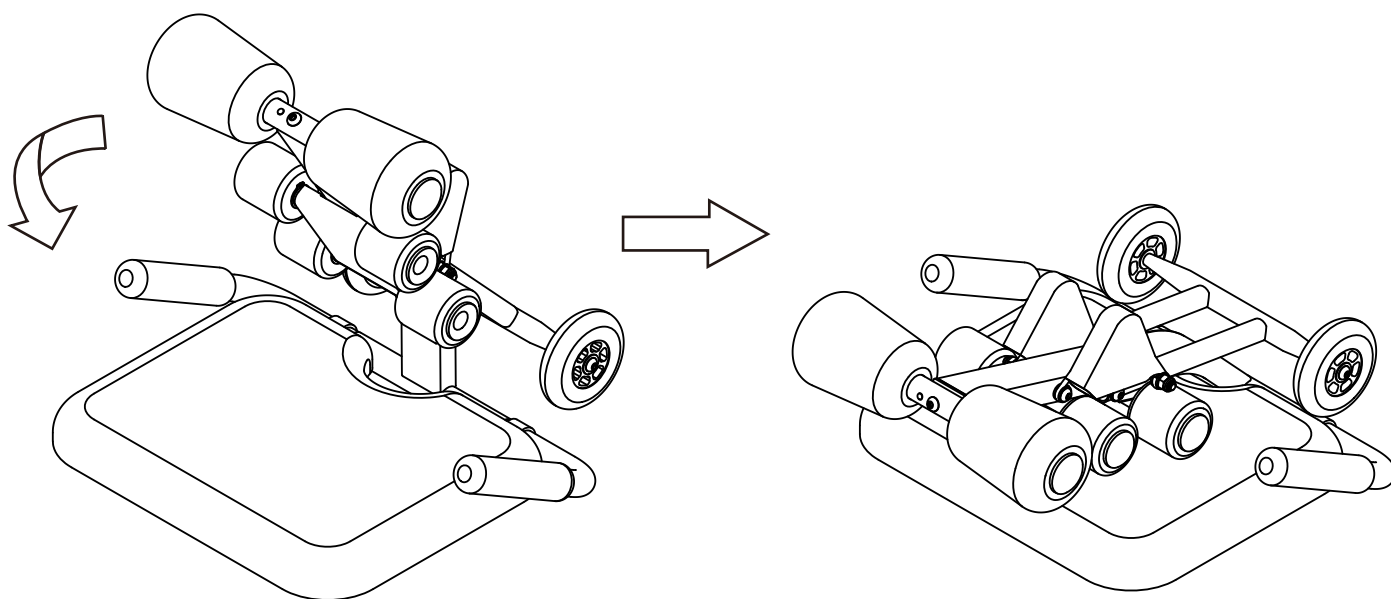

**Make sure that all parts are tightened properly before you use the Power Core.
To protect the floor or carpet from damage, place a mat under the Power Core.**

Benefits of Exercise

A regular exercise program can help improve the quality of your life, help give you more energy and help combat the effects of aging. Research has shown that 30 minutes of cardiovascular exercise done at the same time or even in 3 segments of 10 minutes each combined with a weighted workout 3 to 4 times per week can help deliver the following health benefits:

The benefits of regular participation in a well Balanced fitness program include Weight Loss ‘ Improved Body Shape and Definition Increased Muscle Mass, Strength, Endurance, Power, and Definition Enhanced Flexibility ‘ Increased Metabolism ‘ Injury Protection Improved Self Esteem ‘ Improved Aerobic Fitness Improved Coordination and Agility

Heart Rate

Improved fitness, weight loss and a host of other important health benefits can occur when you exercise at intensity level, which places your heart rate in its target heart zone. Before starting, you must be in good physical condition starting an exercise program. During your workout it is important to exercise in your target heart rate training zone. One of the best ways to know if you’re exercising in your training zone is to monitor your heart rate during the workout. To do this, locate your age on the chart located at the top of next page. This chart shows a lower target heart rate in number beats per minute or beats every 10 seconds. If you are beginning an exercise program, start exercising at this lower heart rate level.

The chart on page 8 shows an upper target heart rate level for those individuals who are in excellent physical condition and have exercised previously. Target heart rates based on your age are to be used as a general guide only. If your fitness level is lower than average for your age, then you may want to work slightly below your target heart rate. If you feel tired, reduce your heart rate and exercise at a lower rate. Overall, the target heart chart is a guide, not a set of rules, so remember to listen to your body at all times.

Pulse count

The pulse count (on your wrist or carotid artery in the neck, taken with two index fingers) is done for ten seconds; take a few seconds after you stop exercising. This is for two reasons: first, 10 seconds is long enough for accuracy. Second, the pulse count is to approximate your BPM rate at the time you are exercising. Since heart rate slows as you recover, a longer count won’t be as accurate.

Beginner Target Heart Rate Chart

The following chart is a guide to those of you who are starting on your fitness program.

AGE	25	30	35	40	45	50	55	60
10Second Count	23	22	22	21	20	19	19	18
Beats Par Minute (BPM)	138	132	132	126	120	114	114	108

Trainings hints

With buying this training item you have done the first step for healthy fitness. With the help of this item you can exercise your muscles at home every time you feel like. Further is the exercise good for your health as the training is also good for your endurance.

Goal of training :

Building of muscles

General fitness

Endurance

Better feeling

The training success is mainly depending on the following points.

Continuous training

Good nourishment

Control of training progress

Who can exercise?

Generally every healthy person, young or old, can start to exercise.

Capacity:

The body, especially the heart and the circulation, need time to adapt to the new circumstances.

Because of this reason it is really important to start really slowly with the training and to make breaks between and after the training. Only exercise on a training level where you don't reach your limit.

Start to exercise in a tempo that you feel comfortable with. After continuous training you can extend your training or adjust the item to a higher level.

Important:

Start your exercise slowly and increase intensity of exercises gradually. You have a lot of time as you do your exercise at home. You have to do some warming –up without item before training.

Start and end your training with a little expenditure or energy. After training you should also do some stretching.

Tips for a successful and healthy training:

- Always remember that the training with your item can be really helpful for your health if you follow the important rules.

It is not helpful to do some exercises in a short time, but in long-term and continuously.

- Please wear comfortable cloth, we propose to wear sporting cloth.

- Never exercise with a full stomach. Do not have a meal about one hour before and after the training.

- Do not exercise if you are already tired or feel exhausted.

- Always remember that your body needs enough liquid if you exercise.

You should follow this necessity.

Training:

Warming up should generally be done with every sportive activity. All physical and psychically components will be stimulated and increased; further the risk or injury will be decreased. With the following exercises you will warm up the muscle groups, this succeed the best by moving.

Run for about 5-10 minutes calmly on one place or through the room. You can jump in between a couple of times.

Stretching:

Following exercises are light but appropriate movements, which will wake up your body, stimulate your circulation and make your ankles more flexible.

Please do these warming up exercises more than once before starting your training.

SUGGESTED STRETCHES

The correct form for several basic stretches is shown at the right. Move slowly as you stretch—never bounce.

1. Toe Touch Stretch

Stand with your knees bent slightly and slowly bend forward from your hips. Allow your back and shoulders to relax as you reach down toward your toes as far as possible. Hold for 15 counts, then relax. Repeat 3 times. Stretches: Hamstrings, back of knees and back.

2. Hamstring Stretch

Sit with one leg extended. Bring the sole of the opposite foot toward you and rest it against the inner thigh of your extended leg. Reach toward your toes as far as possible. Hold for 15 counts, then relax. Repeat 3 times for each leg. Stretches: Hamstrings, lower back and groin.

3. Calf/Achilles Stretch

With one leg in front of the other, reach forward and place your hands against a wall. Keep your back leg straight and your back foot flat on the floor. Bend your front leg, lean forward and move your hips toward the wall. Hold for 15 counts, then relax. Repeat 3 times for each leg. To cause further stretching of the achilles tendons, bend your back leg as well. Stretches: Calves, achilles tendons and ankles.

4. Quadriceps Stretch

With one hand against a wall for balance, reach back and grasp one foot with your other hand. Bring your heel as close to your buttocks as possible. Hold for 15 counts, then relax. Repeat 3 times for each leg. Stretches: Quadriceps and hip muscles.

5. Inner Thigh Stretch

Sit with the soles of your feet together and your knees outward. Pull your feet toward your groin area as far as possible. Hold for 15 counts, then relax. Repeat 3 times. Stretches: Quadriceps and hip muscles.

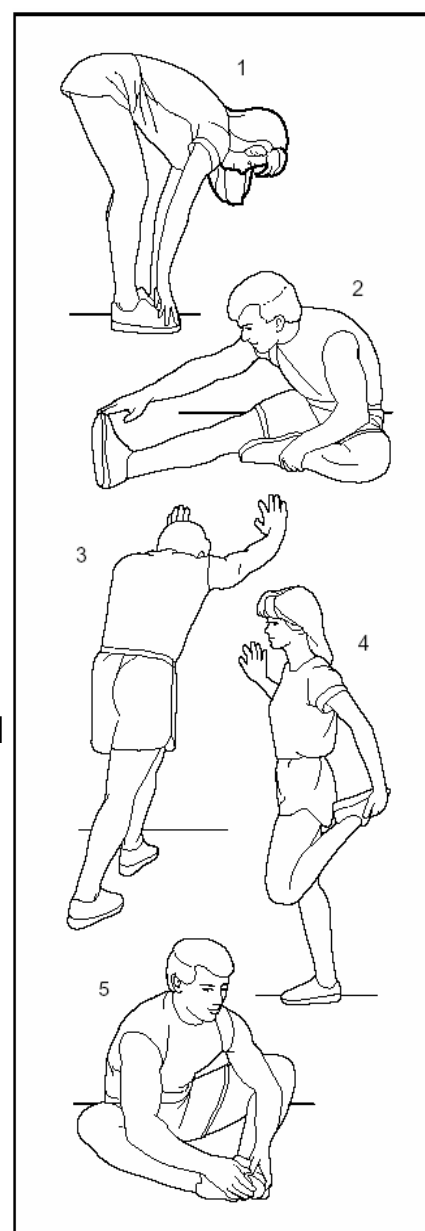

Power Core Parts List					
PART NO.	Description	Q'TY	PART NO.	Description	Q'TY
1	Right base	1	14	Main Frame Pad	2
2	Left base	1	15	Plastic Washer	2
3	Main Frame	1	16	Spring	2
4	Support Frame	1	17	Upper Cap Sets	2
5	Iron Tube	1	18	Lower Cap Sets	4
6	Seat	1	19	Rubber Cap	1
7	Handlebar Foam	2	20	M8x110mm Screw	1
8	Upper Foam Sets	2	21	M8x80mm Screw	1
9	Lower Foam Sets	4	22	M8x45mm Screw	3
10	Wheel	2	23	M8x15mm Screw	4
11	Back Pad Cap	1	24	M8 Washer	10
12	Spring Cap	2	25	M8 Nylon nut	4
13	PU Plug	2			

EXPLODED DRAWING Model No. POWER CORE

