

I N F O

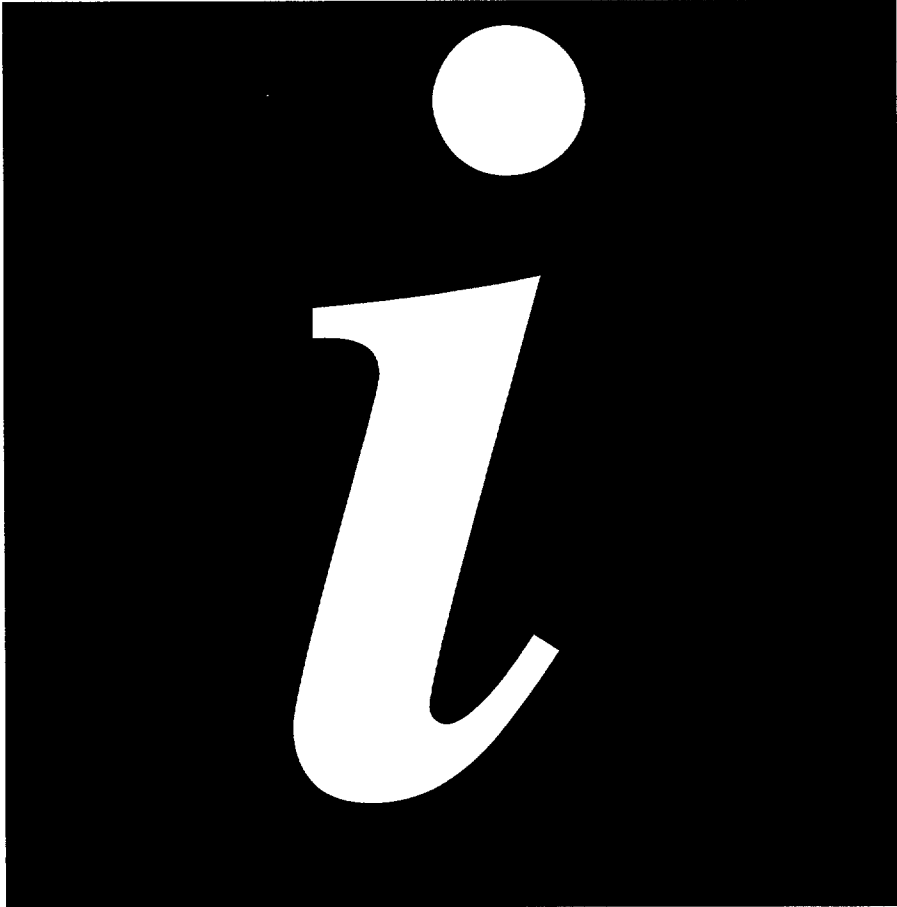

INSTALLATION AND INSTRUCTION MANUAL

FROST FREE FRIDGE/FREEZER ER 7250B

 **Electrolux**

Thank you for buying a ELECTROLUX DOMESTIC APPLIANCE

To enable you to use your appliance effectively and safely, please read this instruction book carefully before using the appliance and retain for future reference. If you require guidance in the use of the appliance or require further information, please contact our Customer Care Department.

CUSTOMER CARE
ELECTROLUX
99 OAKLEY ROAD
LUTON
BEDFORDSHIRE
LU4 9QQ

Tel: 01582 585858

Guide to use the instruction book

The following Symbols will be found in the text to guide you through the instructions



Safety Instructions



Hints and Tips



Step by step instructions
for an operation



Environmental Information



IMPORTANT SAFETY INSTRUCTIONS

These warnings are provided in the interests of your safety. Ensure that you understand them all before installing or using this appliance. Your safety is of paramount importance. If you are unsure about any of the meanings or these warnings contact the Customer Care Department.

Installation

- This appliance is heavy. Care should be taken when moving it.
- It is dangerous to alter the specifications or attempt to modify this product in any way.
- Ensure that the appliance does not stand on the electrical supply cable. If the supply cord is damaged, it must be replaced by a special cord available from your local Service Force Centre.
- Any electrical work required to install this appliance should be carried out by a qualified electrician or competent person.
- Parts which heat up should not be exposed. Whenever possible, the back of the appliance should be close to a wall but leaving the required distance for ventilation as stated in the installation instructions.
- The appliance should be left for 2 hours after installation before it is turned on, in order to allow the refrigerant to settle.

Child Safety

- Do not allow children to tamper with the controls or play with the product.

During Use

- This appliance is designed for domestic use only, specifically for the storage of edible foodstuffs only.
- Frozen food should not be refrozen once it has thawed out.
- Do not place carbonated or fizzy drinks in the freezer.
- Ice lollies can cause 'frost/freezer burns' if consumed straight from the freezer.
- Do not remove items from the freezer if your hands are damp/wet, as this could cause skin abrasions or frost/freezer burns.
- Manufacturers' recommended storage times should be adhered to. Refer to relevant instructions.

Maintenance and Cleaning

- Switch off, and unplug the appliance before carrying out any cleaning or maintenance work.
- Do not use sharp instruments to scrape off frost or ice. (See defrosting instructions).

Servicing

- This product should be serviced by an authorised engineer, and only genuine spare parts should be used.
- Under no circumstances should you attempt to repair the machine yourself. Repairs carried out by inexperienced persons may cause injury or serious malfunctioning. Contact your local Service Force Centre.

At the End of the appliance Life

- When disposing of your appliance, use an authorised disposal site.
- Remove the plug and ensure that any locks or catches are removed, to prevent young children being trapped inside.



Please read this instruction book carefully before use and retain for future reference.

TABLE OF CONTENTS

For the User

Important Safety Instructions	3
Description of the Appliance	5
Control Panel	5
Using Your Appliance	6
Before Use	6
To Start The Appliance	6
Thermostat Control	6
Mains On / Off Switch	7
Indicator Light	7
Low Ambient Temperature Control	7
Larder Compartment	8
<i>Storage Guide</i>	8
<i>Shelf Adjustment</i>	8
The Freezer Compartment	9
<i>Frozen Food Storage</i>	9
<i>Freezing Fresh Food</i>	9
Hints and Tips	10
Food Storage	10
Energy Saving Advice	10
In the Event of a Power Failure	10
Normal Operating Sounds	11
Maintenance and Cleaning	12
Internal Cleaning	12
External Cleaning	12
To Change the Lightbulb	12
Automatic Defrosting	12
When the Appliance is Not in Use	12
What Happens if Something Goes Wrong	13
Peace of Mind For Twelve Months	14
Standard Guarantee Conditions	14
Service	14
Service and Spare Parts	14
Customer Care	14
Service Force Centres	15

For the Installer

Installation Instructions	17
Technical Information	17
Electrical Connections	18
Electrical Requirements	18
Installation	19
Installation Requirements	19
Ventilation Requirements	19
Levelling	19
Door Reversal	20

Description of the Appliance

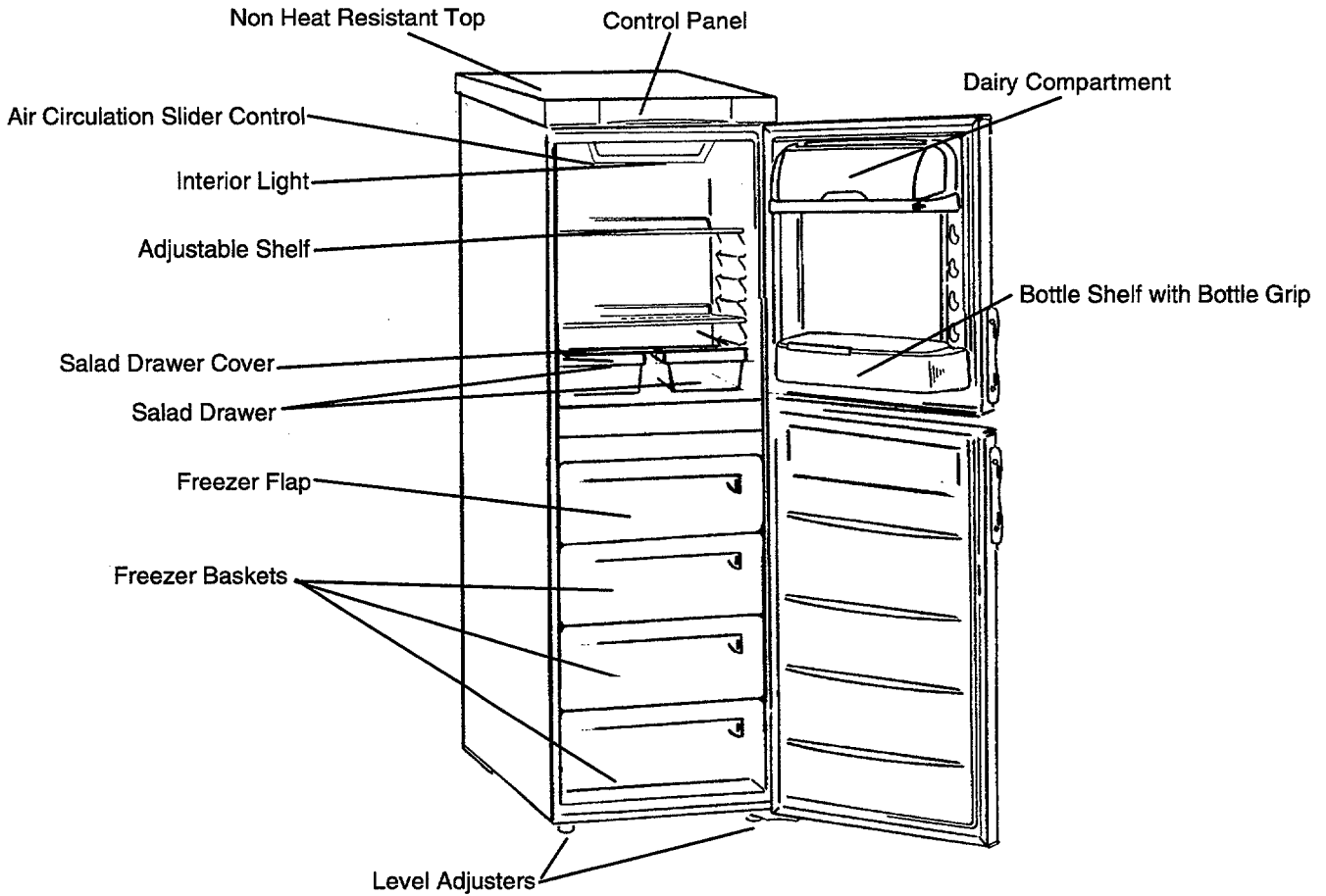

THE FURNISHINGS FROM THE SHRINK WRAP PACK SHOULD BE POSITIONED IN LINE WITH THE ABOVE DIAGRAM

Pack Contents:

Wire Shelf/Trim Assembly (1)
Glass Salad Drawer Cover/Trim
Salad Drawer (2)

Bottle Grippers (2)
Egg Tray
Ice Tray

Control Panel

GREEN INDICATOR LIGHT



IMPORTANT:
PLEASE READ THE
INSTRUCTION BOOK
BEFORE USING THE APPLIANCE



THERMOSTAT



MAINS ON / OFF

USING THE APPLIANCE



This appliance is designed for domestic use only, specifically for the storage of edible foodstuffs.

This appliance is designed to operate in ambient temperatures (surrounding air temperature) between 10°C (50°F) and 32°C (90°F).

If these temperatures are exceeded i.e., colder or warmer, the appliance will not operate correctly. Should the ambient temperatures be exceeded for long periods, the temperature in the freezer section will rise above -18°C and food spoilage may occur.

Before Use

Remove all securing tapes.

Wash the inside of the appliance with lukewarm water with a little bicarbonate of soda added (5ml to 0.5 litre of water). Do not use soap or detergent as the smell may linger. Dry the appliance thoroughly.



Do not use detergents, abrasive powders, highly perfumed cleaning products, wax polishes or products containing alcohol.

To Start the Appliance

1. Allow the appliance to stand for 2 hours after installation.
2. Plug in the appliance and switch on at the mains supply.
3. Turn the thermostat control to the required setting. A midway setting is usually suitable for normal operation (see thermostat control).
4. Leave the appliance for approximately 4 hours for the correct temperature to be reached before placing food inside.

Thermostat Control

The thermostat control is situated under the flap at the front of the top panel. The thermostat control is marked from min to max.

Min (Cold)

Max (Coldest)

The temperature will be affected by:

- Room temperature
- How often the door is opened
- How much food is stored
- Position of the appliance

In determining the correct temperature control setting, all these factors have to be considered and some experimentation may be necessary.



Do not allow children to tamper with the controls or play with the product.

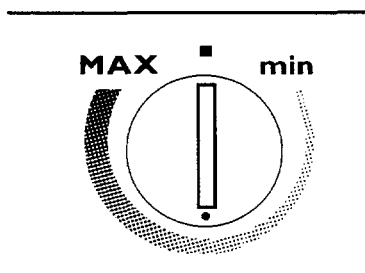

Mains On / Off Switch

For the appliance to operate this switch must be in the I position as well as it being plugged into the mains supply.

Indicator Light

The green indicator light is situated in the control panel under the flap.

When the appliance is switched on at the mains the green indicator light will glow and continue to glow until the appliance is switched off at the mains.

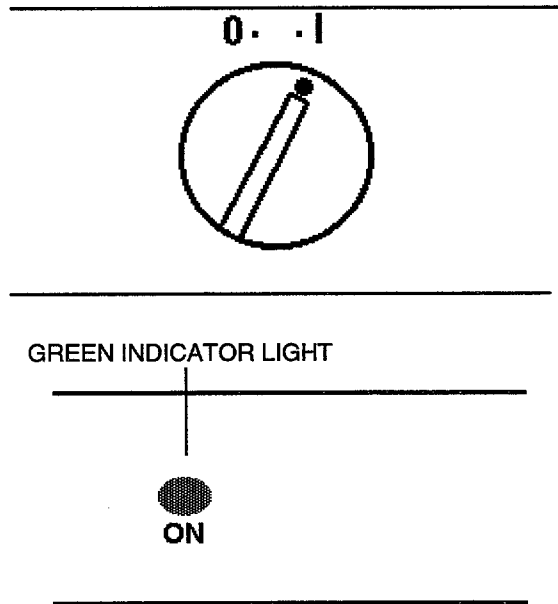

LOW AMBIENT TEMPERATURE CONTROL

Your appliance has been designed to operate in room temperatures of 10°C to 32°C.

By use of an air circulation slider control situated at the rear of the fridge compartment the amount of cold air circulated through the fridge compartment can be varied.

In room temperatures of between 10° and 16°C, should you find your fridge temperatures too cold, reposition the slider control to the "cold" position.

N.B. Positioning the slider control to the "cold" position does not stop the flow of cold air, only restrict it.

At room temperatures above 16°C the slider control can be adjusted between "cold" and "coldest" to increase the amount of cold air circulating through the fridge compartment. Maximum circulation will be achieved with the slider control set at "coldest".

Any further fridge temperature adjustment should be carried out by using the thermostat control (see section headed "Thermostat Control").

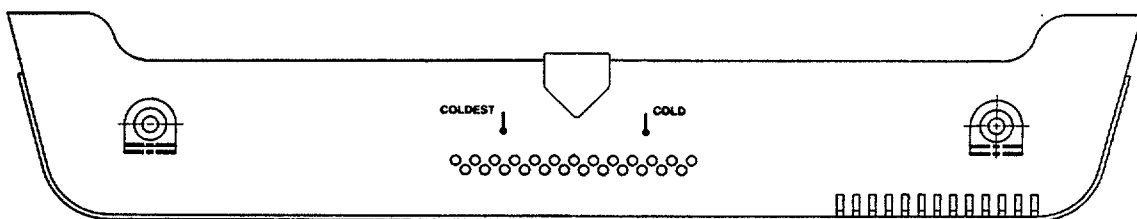

Larder Compartment

The correct temperature for safe storage of fresh food inside is 0°C to 5°C (32°F to 41°F). The warmest part of the fridge compartment is at the top of the cabinet and the coolest at the bottom.

Storage Guide

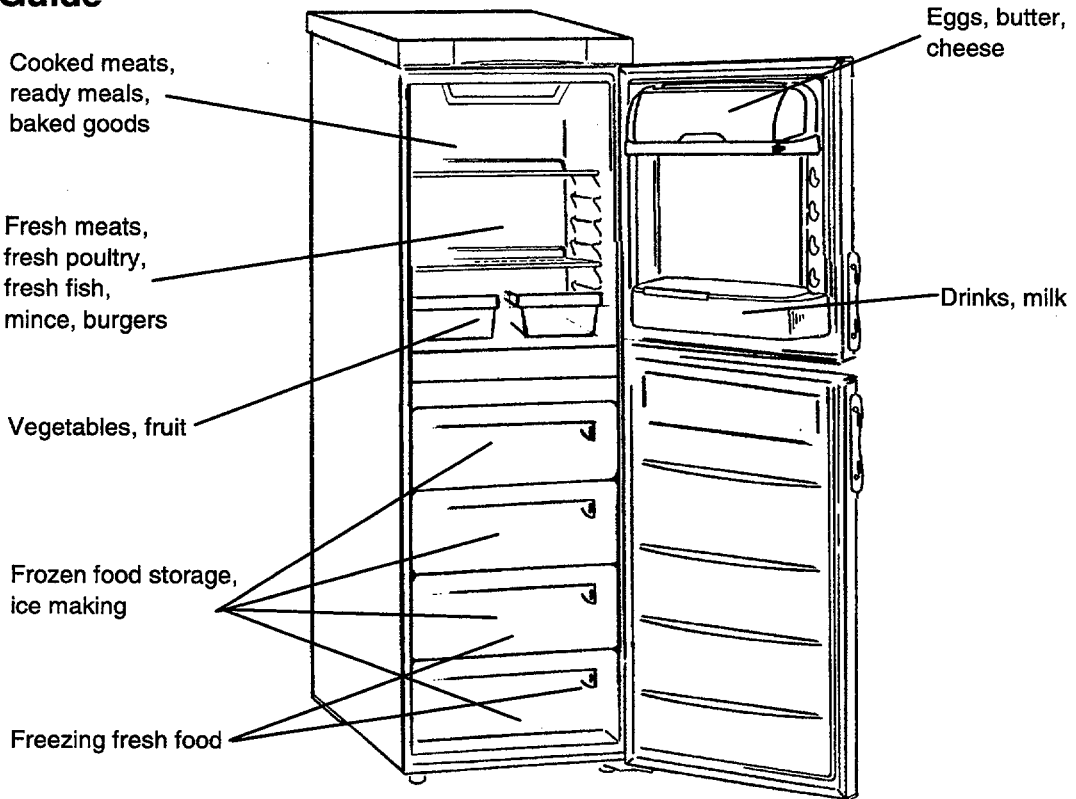

Adjustable shelves

Store light items such as small cartons and jars on the shelves provided in the door. The bottle shelf can be used for the storage of heavier bottles.

The bottle grippers must be fitted to the bottom bottle shelf to ensure bottles are retained securely. Fit the bottle grippers as shown.

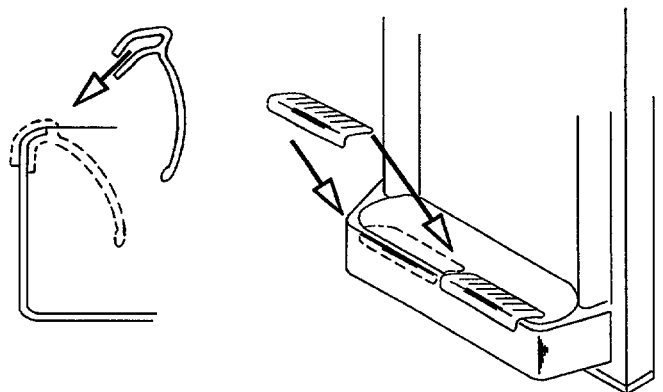

The larder compartment is fitted with shelving which are adjusted for the storage of different sized articles.

The Freezer Compartment

The ******** symbol means that your freezer will store frozen food at -18°C (-0.4°F) or colder allowing for long term frozen food storage and freezing of fresh food. The freezer temperature is controlled automatically by the thermostat situated in the larder compartment.

Due to the different installations, methods of usage and weather conditions, adjustments to the temperature settings may be required.

i These are best assessed against a temperature reading on a thermometer buried in the frozen food. The reading must be taken quickly as the thermometer temperature will rise rapidly after removal.

Frozen Food Storage

The appliance has the following net storage volume:

80 litres (2.8 cuft)
25.6 kg (56.4 lb)[†]

[†] This is a standard measurement and the actual capacity depends upon the density and sizes of the food. The above figures are based on an average density of 0.32kg per litre (20 lb per cuft).

Pre packed commercially frozen food should be stored in accordance with the manufacturer's instructions for a 4 star frozen food compartment and should be put in the freezer as soon as possible after purchase. Your freezer provides for long term storage which generally means up to 3 months but the length of the time can vary and it is important to follow the recommended times shown on packets of commercially frozen food.

! **Do not place sealed containers or carbonated liquids such as fizzy drinks into the freezer as it creates pressure on the container which may cause it to explode resulting to damage to the freezer.**

Ice cubes and ice lollies should not be consumed immediately after removal from the freezer as it may result in low temperature skin abrasions.

Manufacturers storage times should be adhered to.

Freezing Fresh Foods

The maximum quantity of food you can freeze in 24 hours is 6kg. Place the fresh food in the bottom two baskets. Food may need rearranging to achieve this.



Frozen food should not be refrozen once it has thawed out.

Do not remove items from the freezer if your hands are damp/wet, as this could cause skin abrasions or 'frost/freezer burns'.



Hints and Tips

- Any opened packets of frozen food, should be rewrapped in airtight materials to prevent surface evaporation which cause s drying or 'freezer burn'.
- Frozen food which is allowed to thaw accidentally should either be used immediately or thrown away. Alternatively if the food is uncooked and has not been completely defrosted it can be cooked and then refrozen.
- Aim to check dates on packets and rotate food regularly. Although storage longer than recommended is not harmful, flavours and textures begin to change.



HINTS AND TIPS

Food Storage

- To obtain the best results from your appliance, neither hot foods nor liquids which may evaporate, should be placed in the larder compartment.
- Avoid buying frozen food if you cannot store it straight away. The use of an insulated container is advisable. When you arrive home place the frozen food in the freezer immediately.
- Keep the time between buying chilled food and placing it in your fridge as short as possible.
- Do not push food together too much, try to allow air to circulate around each item.
- Do not store food uncovered.
- Ensure that food is placed in the freezer that is dated and labelled and used in date order to ensure that food is consumed at its best.
- Remove suspect food from your refrigerator and clean, refer to cleaning and maintenance.

Energy Saving Advice

- Do not install the cabinet close to sources of heat, such as a cooker, dishwasher or radiator.
- Locate the appliance in a cool well ventilated room and make sure that the air openings of the cabinet are not obstructed.
- Avoid unnecessary frosting in the cabinet by packing all foodstuffs into airtight packages before placing them in the freezer.
- Always leave warm food to cool down to room temperature before placing in the fridge or freezer.
- Food which is to be frozen (when cool) should be placed in the fridge before being transferred to the freezer.

- Thaw frozen food in the fridge. This will ensure safer defrosting of foods and reduce the work of the refrigeration unit.
- Try to avoid keeping the door open for long periods, or opening the door too frequently as warm air will enter the cabinet, and cause the compressor to switch on unnecessarily often.
- Ensure there are no obstructions preventing the door from closing properly.
- It is advisable to periodically clean the refrigeration system at the back of the appliance with a duster or vacuum cleaner.

In the Event of a Power Failure

If there is a power failure during the storage of frozen foods, keep the door closed. If the temperature within your freezer should rise do not refreeze the food without checking it's condition. The following guidelines should assist you:

Ice Cream: Once thawed should be discarded.

Fruit and Vegetables: If soft should be cooked and used up.

Bread and Cakes: Can be refrozen without danger.

Shellfish: Should be refrigerated and used up quickly.

Cooked Dishes: i.e. casseroles, should be refrigerated and used up.

Large Pieces of Meat: Can be re-frozen providing there are ice crystals remaining within them.

Small Joints: Should be cooked and then re-frozen as cooked dishes.

Chicken: Should be cooked and re-frozen as a fresh dish.



HINTS AND TIPS

Normal Operating Sounds

The advanced design of today's frost free appliances mean you hear unfamiliar noises during everyday operation. The diagram below describes some of the noises you may hear. These are quite normal and mean your appliance is operating correctly.

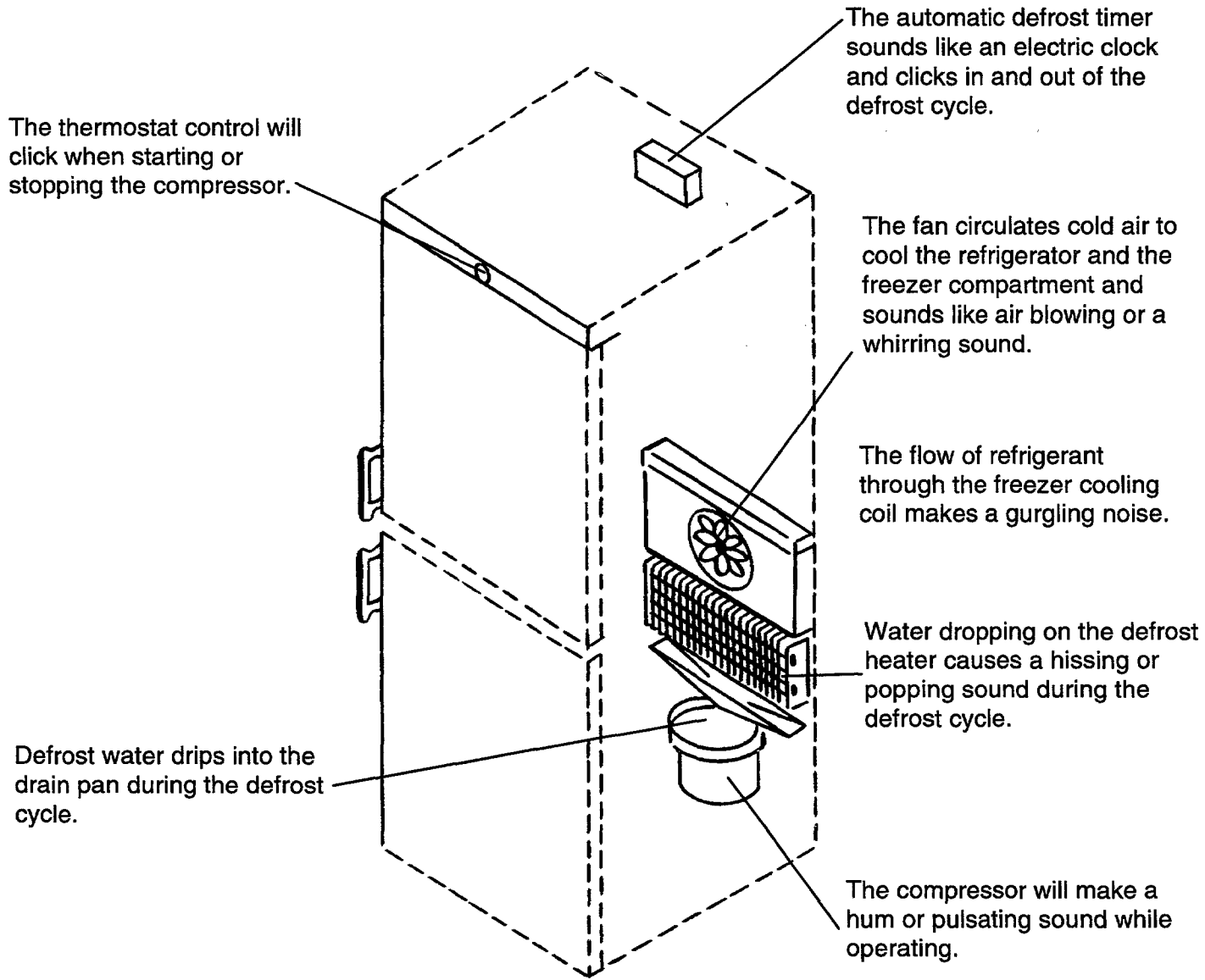

MAINTENANCE AND CLEANING



Before any maintenance or cleaning work is carried out DISCONNECT the appliance from the ELECTRICITY supply.

Internal Cleaning

Clean the inside and accessories with warm water and bicarbonate of soda (5ml to 0.5 litre of water). Rinse and dry thoroughly.



Do not use detergents, abrasive powders, highly perfumed cleaning products, wax polishes or cleaning products containing bleach or alcohol.

Regularly check the door seals and wipe clean to ensure they are clean and free from debris.

External Cleaning

Wash the outer cabinet with warm soapy water.



Do NOT use abrasive products.

There are sharp edges on the underside of the product so care should be taken when cleaning.

Once or twice a year dust the condenser (black grille) and the compressor at the back of the appliance, with a brush or vacuum cleaner, as an accumulation of dust will affect the performance of the appliance and cause excessive electricity consumption.

To Change the Light Bulb

1. Switch off the appliance and disconnect from the electricity supply.
2. Remove from the light cover by removing the screw at the rear with a screwdriver.
3. Pull the cover outwards towards the middle of the cabinet.
4. Unscrew the bulb and replace it with a new 15 watt E14 SES bulb (available from your local Service Force Centre).
5. Replace the cover by sliding it into its original position.
6. Replace the screw.

Automatic Defrosting

Your appliance has been designed to be frost free. This means there is no need to defrost your appliance as this will be carried out automatically.

When the Appliance is Not in Use

When the appliance is not in use for long periods, disconnect from the electricity supply, empty all of the food and clean the appliance, leaving the door ajar to prevent unpleasant smells.

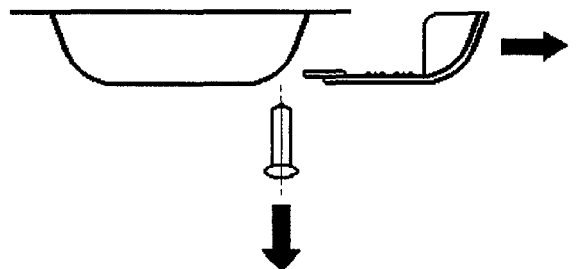
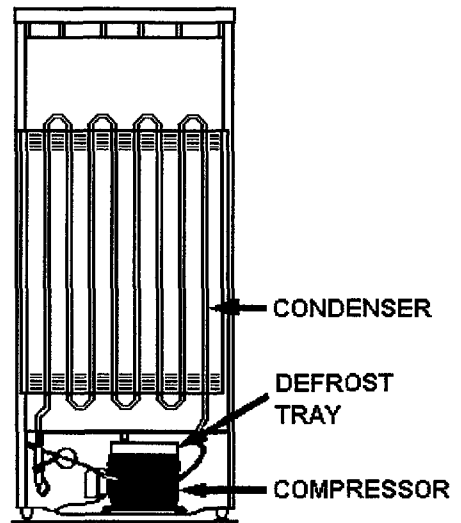

WHAT HAPPENS IF SOMETHING GOES WRONG

BEFORE contacting your local service force centre, check the following points:

Symptom	Solution
No power to the appliance	Check there is power at the socket.
	Check there is not a power cut by checking the household lights.
	Check the fuse has not blown.
The light does not come on	Ensure that the bulb is correctly fitted.
	Replace the bulb if it has blown.
	Check the door light switch is not jammed.
The temperature in the fridge or freezer section is too high	Check the thermostat is turned to the correct setting relative to ambient conditions.
	Check the ambient temperature is within the appliances operating limits of 10°C to 32°C. Relocate the appliance if necessary.
The freezer door will not open	Has door just been opened? If so leave for a few minutes to allow the air pressure to equalise.
The compressor runs continuously	Adjust the thermostat to give correct temperature control. See page 6.
	Check that the doors are closed.
	Large quantities of food have recently been placed in the cabinet / and or door is frequently opened.
	Check that air ventilation is not obstructed.
Excessive frost and ice has built up	Ensure the doors are not left open.
	Check that nothing is preventing the doors from closing.
	Is the door gasket intact and clean.
Noise	Refer to normal operating sounds.

If after the above checks there is still a fault call your local Service Force Centre.

In-guarantee customers should ensure that the above checks have been made as the engineer will make a charge if the fault is not a mechanical or electrical breakdown.

Please note that proof of purchase is required for in-guarantee service calls.

Peace of Mind for Twelve Months

STANDARD GUARANTEE CONDITIONS

We, Electrolux, undertake that if within twelve months of the date of the purchase, this Electrolux appliance or any part thereof is proved to be defective by reason only of faulty workmanship or materials, the company will, at its option repair or replace the same FREE OF CHARGE for labour, materials or carriage on condition that:

- The appliance has been correctly installed and used only on the electrical supply stated on the rating plate.
- The appliance has been used for normal domestic purposes only, and in accordance with the manufacturer's operating and maintenance instructions.
- The appliance has not been serviced, maintained, repaired, taken apart or tampered with by any person not authorised by us.

Any service work under this guarantee must be undertaken by an Electrolux service representative or authorised agent.

This guarantee is in addition to your statutory and other legal rights.

Home visits are made between 8.30am and 5.30pm Monday to Friday. Visits may be available outside these hours in which case a charge will be made.

Service and Spare Parts

If you require service or spare parts please contact your local Service Force Centre by telephoning:

0990 929929

The address of your local centre can be found on the following pages; and also in your local telephone directory.

Before contacting your local Service Force Centre make a note of the model and serial number, together with date of purchase. The service department will require this information.

The model and serial number can be found on the rating plate situated inside the cabinet.

EXCLUSIONS

This Guarantee does not cover:

- Damage or calls resulting from transportation, improper use or neglect, the replacement of any light bulbs or removable parts of glass or plastic, or vacuum cleaner drive belts, brushes or dust bags.
- Costs incurred for calls to put right an appliance which is improperly installed or calls to appliances outside the United Kingdom.
- Appliances found to be in use within a commercial environment, plus those which are subject to rental agreements.
- Products of Electrolux manufacture which are not marketed by Electrolux.
- **EU Countries.** The standard guarantee is applicable but is subject to the owner's responsibility and cost to ensure the appliance meets the standards set by the country to which the product is taken. Proof of purchase may be required. Electrolux Aftersales Service in the country concerned, will be pleased to advise further.

CUSTOMER CARE

For general enquiries concerning your Electrolux appliance, or further information on Cookers, Microwaves, Refrigeration or Home Laundry equipment you are invited to contact our Customer Care Department by letter or telephone as follows:

Electrolux
99 Oakley Road
Luton
Bedfordshire
LU4 9QQ

Tel: 01582 585858

SERVICE FORCE CENTRES

To contact your local Service Force Centre telephone 0990 929929

SCOTLAND

ABERDEEN (M05)	8 Cornhill Arcade Cornhill Drive Aberdeen AB2 5UT
AUCHTERMUCHY (M03)	33A Burnside Auchtermuchy Fife KY14 7AJ
ARGYLL (M67)	Briar Hill 7 Hill Street, Dunoon Argyll PA23 7AL
BLANTYRE (M07)	Unit 5 Block 2 Auchenraith Industrial Estate Rosendale Way Blantyre G72 0NJ
DUMFRIES (M01)	93 Irish Street Dumfries Scotland DG1 2PQ
DUNDEE (M70)	3-7 Blackness Street Dundee DD1 5LR
DUNOON (OWN SALES)	S Gibson 96 Argyll Street Dunoon PA23 7NE
GLASGOW (M04)	20 Cunningham Road Clyde Estate Rutherglen, Glasgow, G73 1PP
INVERNESS (M06)	Unit 3B Smithton Indust. Est. Smithton Inverness IV1 2PD
ISLE OF ARRAN (OWN SALES)	Arran Domestics Unit 4 The Douglas Centre Brodict Isle of Arran KA27 8AJ
ISLE OF ARRAN (OWN SALES)	Ronnis Hagerty Bruach Blackwaterfoot Isle of Arran
ISLE OF BARRA (OWN SALES)	J Zerfah 244 Bruernish Isle of Barra Western Islands HS9 5QY
ISLE OF BUTE (M66)	Walker Engineering Glenmhor Upper Serpentine Road Rothesay Isle of Bute PA20 9EH
ISLE OF LEWIS (M69)	ND Macleod 16 James Street Stornoway Isle of Lewis PA87 2QW

ISLE OF MULL (M68)	Brian Hogg Braeside Raeric Road Tobermory Isle of Mull PA75 6PU
KELSO (M08)	2-8 Wood Market Kelso Borders TD5 7AX
ORKNEY (M65)	Refrigeration Sales & Service Hatson Industrial Estate Kirkwall Orkney KW15 1RE
SHETLAND (OWN SALES)	George Robertson 3/4 Carlton Place Lerwick Shetland ZE1 0ED
SHETLAND (OWN SALES)	Tait Electronic Systems Ltd. Holmsgarth Road Lerwick Shetland ZE1 0PW
SHETLAND (OWN SALES)	Bolts Shetland Ltd 26 North Road Lerwick Shetland ZE1 0PE
WHALSAY (OWN SALES)	Leask Electrical Hartsdale Symbister, Whalsay Shetland ZE2 9AA

NORTH EAST

GATESHEAD (M39)	Unit 356a Dukesway Court Dukesway Team Valley Gateshead NE11 0BH
GRIMSBY (M42)	Unit 2 Cromwell Road Grimbsy South Humberstone DN31 2BN
HULL (M41)	Unit 1 Boulevard Industrial Estate Hull HU3 4AY
LEEDS (M37)	64-66 Cross Gates Road Leeds LS15 7NN
NEWTON AYCLIFFE (M45)	Unit 16 Gurney Way Aycliffe Ind Estate Newton Aycliffe DL5 6UJ
SHEFFIELD (M38)	Pennine House Roman Ridge Ind. Roman Ridge Road Sheffield S9 1GB

NORTHERN IRELAND

BELFAST (M27)	Owenmore House Kilwee Industrial Estate Upper Dunmury Lane Belfast BT17 0HD
------------------	---

WALES

CARDIFF (M28)	Guardian Industrial Estate Clydesmuir Road Tremorfa, Cardiff CF2 2QS
CLYWD (M14)	Unit 6-7 Coed - Parc Abergele Road Rhuddlan Clwyd Wales LL18 5UG
OSWESTRY (M17)	Plas Funnon Warehouse, Middleton Road Oswestry SY11 2PP

NORTH WEST

BIRKENHEAD (M11)	1 Kelvin Park Dock Road Birkenhead L41 1LT
CARLISLE (M10)	Unit 8 South John Street Carlisle CA2 5AJ
ISLE OF MAN (M64)	South Quay Ind Estate Douglas Isle of Man
LIVERPOOL (M15)	1 Honeys Green Precinct Honeys Green Lane West Derby Liverpool L12 9JH
MANCHESTER (M09)	Unit 30, Oakhill Trading Estate Devonshire Road Worsley Manchester M28 3PT
PRESTON (M13)	Unit 250 Dawson Place Walton Summit Bamber Bridge Preston Lancashire PR5 8AL
STOCKPORT (M16)	Unit 20 Haigh Park Haigh Avenue Stockport SK4 1QR

SERVICE FORCE CENTRES

To contact your local Service Force Centre telephone 0990 929929

MIDLANDS

BIRMINGHAM (M18)	66 Birch Road East, Wyrley Road Industrial Estate Witton Birmingham B67DB
BOURNE (M44)	Manning Road Ind Estate Pinfold Road Bourne PE10 9HT
GLOUCESTER (M23)	134 Eastgate Street Gloucester GL1 1QT
HEREFORD (M31)	Unit 3 Bank Buildings Cattle Market Hereford HE4 9HX
HIGHAM FERRERS (M51)	The Old Barn Westfield Terrace Higham Ferrers NN10 8BB
ILKESTON (M43)	Unit 2 Furnace Road Ilkeston DE7 5EP
LINCOLN (M40)	Unit 8 Stonefield Park Clifton Street Lincoln LN5 8AA
NEWCASTLE UNDER LYME (M12)	18-21 Croft Road Brampton Industrial Estate Newcastle under Lyme Staffordshire ST5 0TW
NUNEATON (M21)	19 Ptarmigan Place Townsend Drive Nuneaton CV11 6RX
NUNEATON (M22)	Unit 23-24 Alliance Business Pk Townsend Drive Nuneaton Warwickshire CV11 6RX
REDDITCH (M20)	Heming Road Washford Redditch Worcestershire B98 0DH
TAMWORTH (M19)	Unit 3 Sterling Park Claymore Tamworth B77 5DO

LONDON & EAST ANGLIA

CANVEY ISLAND	2-4 Sandhurst Kings Road Canvey Island SS8 0QY
ENFIELD (M49)	284 Alma Road Enfield London EN3 7BB
GRAVESEND (M57)	Unit B4, Imperial Business Estate Gravesend Kent DA11 0DL
HARPENDEN (M46)	Unit 4 Riverside Estate Coldharbour Lane Harpenden AL5 4UN
MAIDENHEAD (M60)	Reform Road Maidenhead Berkshire SL6 8BY
MOLESEY (M61)	10 Island Farm Avenue West Molesey Surrey KT8 2UZ
IPSWICH (M48)	Unit 2B Elton Park Business Centre Hadleigh Road Ipswich IP2 0DD
NORWICH (M52)	2b Trafalgar Street Norwich NR1 3HN
SUNBURY (M63)	Unit 1a The Summit Hanworth Road Hanworth Ind Estate Sunbury on Thames TW16 5D
SYDENHAM (M62)	Unit 6 Metro Centre Kangley Bridge Road Sydenham SE26

SOUTH EAST

ASHFORD (M58)	Unit 2 Bridge Road Business Est Bridge Road Ashford Kent TN2 1BB
FLEET (M59)	Unit 1 Redfields Industrial Estate Church Crookham Fleet Hampshire GU13 0RD
HAYWARDS HEATH (M55)	21-25 Bridge Road Haywards Heath Sussex RH16 1UA

TONBRIDGE (M56)	Unit 30 Deacon Trading Estate Morley Road Tonbridge Kent TN9 1RA
-----------------	--

SOUTH WEST

BARNSTAPLE (M30)	P.O. Box 12 Barnstaple North Devon EX31 2YB
BOURNEMOUTH (M26)	63-65 Curzon Road Bournemouth Dorset BH1 4PW
BRIDGEWATER (M35)	6 Hamp Industrial Estate Bridgewater Somerset
BRISTOL (M25)	11 Eldon Way Eldonwall Trading Bristol Avon BS4 3QQ
EMSWORTH (M33)	266 Main Road Southbourne Emsworth PO10 8JL
GUERNSEY	Guernsey Electricity PO Box 4 Vale, Guernsey Channel Islands
ISLE OF WIGHT (M34)	Unit 8 Enterprise Court Ryde Business Park Ryde Isle of Wight PO33 1DB
JERSEY	Jersey Electricity Company PO Box 45 Queens Road St Helier Jersey Channel Islands JE4 8NY
NEWTON ABBOT (M29)	Unit 2 Zealley Industrial Estate Kingsteignton Newton Abbot S. Devon TQ12 3TD
PLYMOUTH (M32)	16 Faraday Mill Cattledown Plymouth PL4 0ST
REDRUTH (M36)	Unit 7D Pool Industrial Estate Wilson Way, Redruth, Cornwall TR15 3QW

INSTALLATION INSTRUCTIONS

Technical Information

DIMENSIONS

HEIGHT: 138.8 cm (54.65")

WIDTH: 55.3 cm (21.77")

DEPTH: 61.5 cm (24.21")

CAPACITY

GROSS: FRIDGE 104 litres
FREEZER 96 litres

NET: FRIDGE 102 litres
FREEZER 80 litres

POWER ABSORBED: 150W

VOLTAGE: 230 - 240V

FREQUENCY: 50Hz

AVERAGE DAILY UNITS OF ELECTRICITY: 2.1Kwh *

* THIS FIGURE IS BASED ON STANDARD TEST RESULTS IN THE EUROPEAN STANDARD EN153. ACTUAL CONSUMPTION WILL DEPEND ON HOW THE APPLIANCE IS USED AND WHERE IT IS LOCATED.



This appliance complies with the following E.E.C Directives:
73/23 EEC of 19.2.73 (Low Voltage Directive) and subsequent modifications;
89/336 EEC of 3.5.89 (Electromagnetic Compatibility Directive) and subsequent modifications.



It is dangerous to alter the specifications or attempt to modify this product in any way.

Electrical Connections



Any electrical work required to install this appliance should be carried out by a qualified electrician or competent person.

This appliance must be earthed.

The manufacturer declines any liability should these safety measures not be observed.

Electrical Requirements

Before switching on, make sure the electricity supply voltage is the same as that indicated on the appliance rating plate.

The appliance is supplied with a 13 amp plug fitted. In the event of having to change the fuse in the plug supplied, a 13 amp ASTA approved (BS1362) fuse must be used.

Should the plug need to be replaced for any reason. The wires in the mains lead are coloured in accordance with the following code:

Green and Yellow	: Earth
Blue	: Neutral
Brown	: Live

The wire coloured green and yellow must be connected to the terminal marked with the letter "E" or by the earth symbol  or coloured green and yellow.

The wire coloured blue must be connected to the terminal marked "N" or coloured black.

The wire coloured brown must be connected to the terminal marked "L" or coloured red.

Upon completion there must be no cut, or stray strands of wire present and the cord clamp must be secure over the outer sheath.

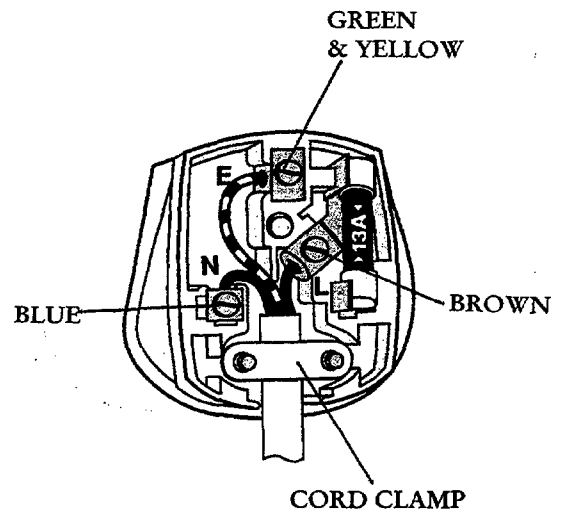

Installation Requirements

To ensure correct operation this appliance must not be located where the temperatures will fall below 10°C (50°F) or rise above 32°C (90°F).

Avoid the following locations: unheated kitchen, outhouse, conservatory, garage.

For correct operation this appliance must be installed:

- In a dry atmosphere.
- Out of direct sunlight.
- Away from extreme temperature (not next to a cooker or other sources of heat).
- Your appliance will be heavy when loaded with food and must therefore be stood on a strong firm floor.

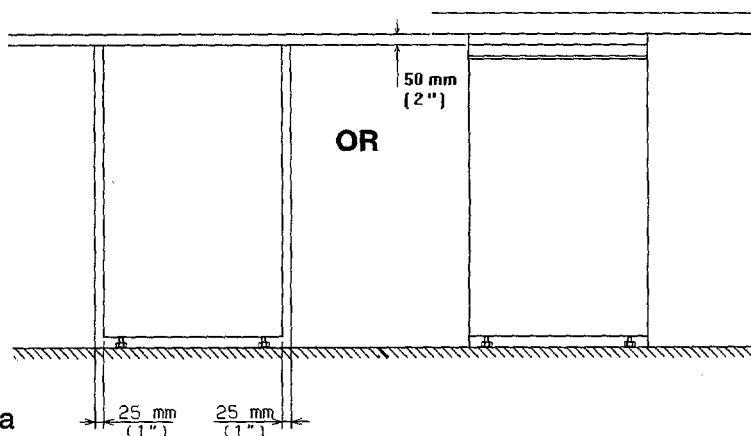

Ventilation Requirements

- Gently push into place until the top panel rear ventilation grill touches against the wall.
- When in position a 50 mm (2") clear space above the appliance should be maintained.
- If space above the appliance is not available, clearance of 25mm (1") should be maintained on both sides.

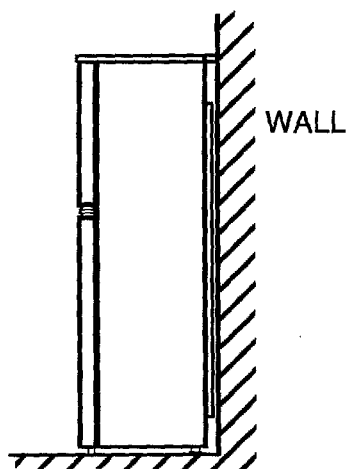

 *Ensure that the appliance does not stand on the electrical supply cable.*

 *Parts which heat up should not be exposed. Whenever possible, the back of the appliance should be close to a wall but leaving the required distance for ventilation.*

Levelling

The appliance should be level, to eliminate rocking:

- Ensure the appliance is upright and both adjusters are in firm contact with the floor so that the cabinet is level.
- Adjust the level by screwing out the appropriate level adjuster at the front, (use your fingers or a suitable spanner).

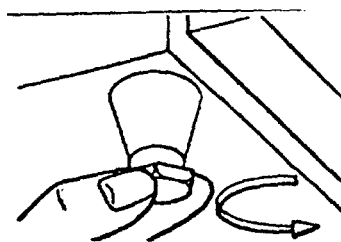

 *This appliance is heavy. Care should be taken when moving it.*

Door Reversal

1. Disconnect it from the electricity supply.
2. Remove all loose items, including food. Store food in a cool place.
3. Make sure a towel or cloth is at the base of the product to prevent it from slipping.
4. Carefully lean the appliance backwards, resting the top on a stool, or something similar, at least 30cm (12") from the floor. (care must be taken not to allow the appliance wheels to slip).

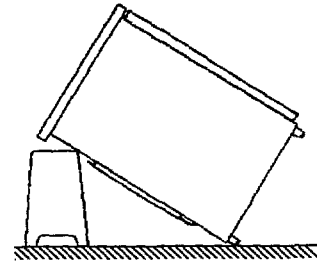

 **Do not support the appliance on the rear ventilation grille or condenser.**

5. Remove level adjuster (A) from base of product retaining small cup spacer which is located around the threaded portion of the adjuster.
6. Remove the foot / hinge assembly (B) by removing screws marked (C).
7. Remove the bottom door by lifting it upwards slightly and carefully sliding it down off the centre hinge pin (H).
8. Remove blanking plate (M) using a flat blade screwdriver.
9. Remove the centre hinge (H) by loosening screw (G) and removing totally screw (J). Remove the top door by carefully sliding it down off the upper hinge pin (P).
10. Unscrew the upper hinge pin (P) and transfer it to the opposite side of the cabinet.
11. Refit blanking plate (M) onto the opposite side of the cabinet.

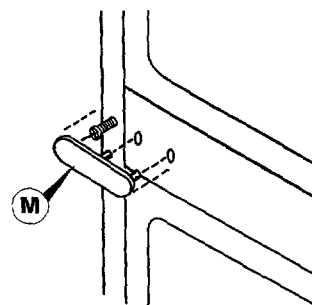
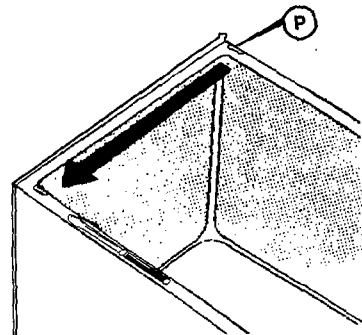
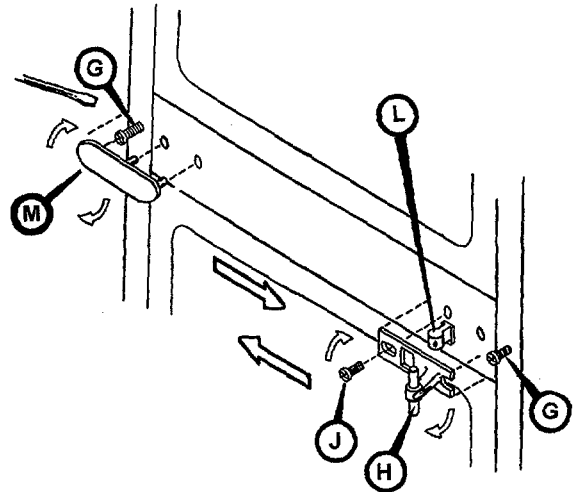
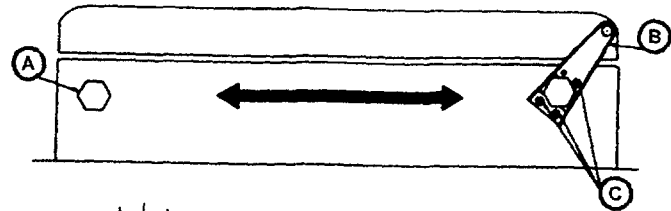

12. Next stage is to remove the door closure device fitted on each door handle.
- Remove blanking plug (N) on each door handle by using a flat bladed screwdriver.
- Remove door closure device (R) by removing screw (S) on both doors and fit to opposite side of door. Note that the door closure device is handed so when transferring it to the opposite side the device which was on the bottom of the top door will now be fitted to the top of the bottom door and visa versa.
- Now replace blanking plug (N) in the opposite side of each door.
- Refit the top door by carefully sliding it onto the upper hinge pin (P).

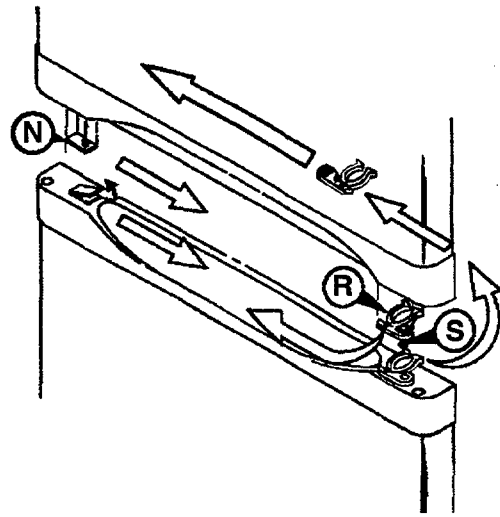

13. Refit the top door by carefully sliding it onto the upper hinge pin (P).
14. Turn the centre hinge (H) around from its illustrated position and transfer it to the opposite side. Gently press the centre hinge up into the door being careful to retain the door closure clip (L).
- To secure the centre hinge to the cabinet, refit screw (J). Ensure the top door is correctly aligned before fully tightening the screws (J) and (G). This can be achieved by sideways movement of the centre hinge. The base of your product should now be in line with the diagram.

15. Refit the bottom door by sliding it onto the centre hinge pin. Take the bottom hinge foot assembly (B) and transfer it over to the opposite side of the cabinet being careful to retain any spacing washer fitted onto the bottom hinge pin. Push the hinge foot assembly (B) into the door bearing using the pin of the foot for location. Three holes will then line up with the hinge foot and screws (C) should be used to secure the hinge. Refit level adjuster and spacer (A) in the opposite side of the cabinet.

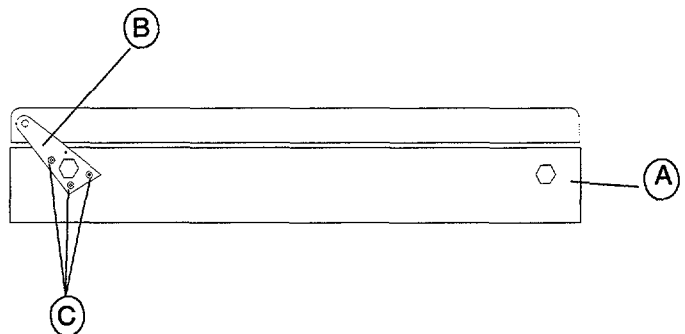

16. The base of your product should now be in line with the diagram.
17. Stand the appliance upright.

FROST FREE FRIDGE FREEZER ER7250B 822020531-01