

HI-3637
VLF Magnetic Field Meter
User's Manual

Declaration of Conformity

We,
HOLADAY INDUSTRIES, INC.
14825 MARTIN DRIVE
EDEN PRAIRIE, MN 55344
USA



declare in our own responsibility, that the HOLADAY product described in this instruction manual is in compliance with: EN EMC Directive 89/336/EEC, EN50082-1, EN55011

President
HOLADAY INDUSTRIES, INC.

Copyright © 1993 by Holaday Industries, Inc.

Manual #600055 2/00

\$12.50

Revision Record

Manual #600055
HI-3637 VLF Meter

<u>Revision</u>	<u>Description</u>	<u>Date</u>
---	Release	9/93
A	Rev. Spec	4/94
B	Added CE Label	10/97
C	Update Recorder Output Level	01/00
D	Changed Area Code	2/00

TABLE OF CONTENTS

1.0 DESCRIPTION	1
Introduction	1
2.0 SPECIFICATIONS	3
3.0 ACCEPTANCE AND CONTROLS	7
Introduction	7
Unpacking and Acceptance	7
Battery	7
Battery Charger	7
Controls, Indicators and Connectors	9
Recorder Output	10
Low Battery Indication	11
4.0 BATTERY CHARGING	13
Introduction	13
Battery Tips	13
Charging Procedure	14
Charging Considerations	14
Battery Replacement	15
5.0 MAINTENANCE	17
Introduction	17
Maintenance Recommendations	17
Return Procedures	17
Periodic/Preventive Maintenance	18
Parts Information	19
6.0 MAKING MEASUREMENTS	21
Quick Start	21
Description	22

7.0 THEORY OF OPERATION	23
Introduction	23
Probe	23
Range Select	23
Pre-filter Section	23
Integrator Section	25
Post-filter Section	25
RMS Calculation	25
Power supply	25
8.0 CALIBRATION	27
9.0 REFERENCES	29
APPENDIX A	
VIDEO DISPLAY TERMINALS (VDTs)	31
VDT CHARACTERISTICS	31
General Description	31
Principles of Operation	31
Modulated DC Fields	32
60/50 Hz Fields	33
Deflection System Fields	33
Broadband RF Fields	34
CHARACTERIZING VDT EMISSIONS AND OPERATOR EXPOSURE	35
Introduction	35
Characterizing VDT Emissions	35
GUIDELINES FOR RF EXPOSURE	37

Limited Warranty

Holaday Industries, Inc. warrants each model HI—3637 3-Axis VLF Magnetic Field Meter to be free from defects in material and workmanship for a period of one year from the date of shipment to the purchaser. This warranty extends to the original purchaser only, and does not apply to the batteries or to any products or parts subject to misuse, neglect, accident, unauthorized service or abnormal conditions of operation.

In the event an instrument covered by this warranty fails, Holaday Industries, Inc. will, without charge, repair and recalibrate the instrument if returned to their factory within one year of the original purchase—provided that Holaday Industries' examination discloses, to its satisfaction, that the product is defective. Holaday Industries, Inc., may, at its option, replace the product in lieu of repair. If the defect was caused by misuse, neglect, accident, unauthorized service or abnormal conditions of operation, repairs will be billed at a nominal cost. In such cases, an estimate will be provided before work is started, if requested by the purchaser.

For warranty service, contact Holaday Industries, Inc. Provide the serial number of the instrument and complete details regarding the failure mode. You will then be given either service information or shipping instructions. Return the instrument to the factory, transportation prepaid. Repairs will be made at the factory and the instrument will be returned to you, transportation prepaid. Holaday Industries, Inc., assumes no responsibility for loss of, or damage to, products in transit.

Warning!

EXTREME CAUTION IS ADVISED WHEN WORKING IN ENVIRONMENTS WHERE CONTACT WITH HIGH VOLTAGE OR HIGH CURRENT CIRCUITS OR APPARATUS IS POSSIBLE. THIS IS PARTICULARLY TRUE WHEN ATTEMPTING TO OBTAIN ELECTRIC OR MAGNETIC FIELD STRENGTH MEASUREMENTS IN CONFINED QUARTERS SUCH AS INSIDE CABINETS CONTAINING ELECTRICALLY OPERATED EQUIPMENT, ELECTRIC POWER SUBSTATIONS OR IN VERY CLOSE PROXIMITY TO THE CONDUCTORS OF ENERGIZED POWER LINES. ACCIDENTAL CONTACT WITH OBJECTS OR CIRCUITS OPERATED AT HIGH VOLTAGES OR HIGH CURRENTS CAN BE LETHAL! HOLADAY INDUSTRIES, INC. ASSUMES NO LIABILITY

1.0 DESCRIPTION

Introduction

The HI-3637 VLF (very-low frequency) Magnetic Field Meter measures magnetic field flux density in the frequency range of 2 kHz to 400 kHz. The capabilities of this instrument are designed to conform to the guidelines issued recently in Sweden—as well as the IEEE P-1140 protocol—for measuring VLF magnetic fields produced by video display terminals (VDTs). Applications for this versatile meter range from VDTs and computer monitors to high current factory locations.

The HI-3637 is a self-contained three-axis flux density meter designed to respond to either sinusoidal or complex magnetic field waveforms, such as those produced by the vertical deflection system of a VDT. The meter circuit utilizes a microprocessor to continually compute the root-mean-square (RMS) value of magnetic field flux density and display it directly on an analog meter, allowing quick assessment of the actual flux density value. The size of the instrumentation/readout package was chosen for two reasons. The first is to allow for two layers of electric and magnetic shielding in addition to the outer housing. The second is to allow for hand held operation. This portability makes the HI-3637 particularly useful in surveying the magnetic field flux density distribution over a large area in a short amount of time.

The probe sensor array consists of three mutually orthogonal multi-turn loops connected to the instrumentation/readout package via a 1.5 meter cable. Readings are independent of probe orientation. The probe is electrically shielded, making the HI-3637 immune to most electric field effects.

The HI-3637 has a wide dynamic measurement range: 4 nT to 400 : T (100 dB). This makes the HI-3637 convenient for finding VLF magnetic field distributions in any application. The supplied alternate panel label converts the meter scale to Gauss (0.04 mG to 4 G).

The optional X100 probe shifts the measurement range to 400 nT to 40 mT (6 mG to 400 G). An optional kit converts the HI-3637 to indicate fields in field strength units of amps/meter (A/m). See table 5-2 for optional equipment.

2.0 SPECIFICATIONS

Frequency

Response:

2 kHz	- 3 dB
400 kHz	- 3 dB
< 2 kHz	80 dB/decade rolloff
> 400 kHz	40 dB/decade rolloff

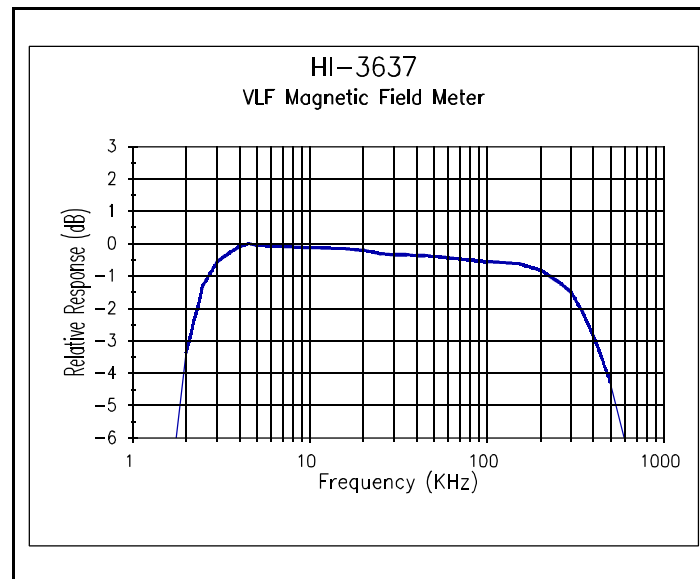

Figure 8-1
HI-3637 Response Curve

Detector Response: True RMS field indication for accurate measurement of non-sinusoidal waveforms.

Dynamic Range: 100 dB

Ranges:

<i>Standard:</i>	40 nT, 400 nT, 4 : T, 40 : T, 400 : T full scale*
<i>Alternate Scale:</i>	0.4 mG, 4 mG, 40 mG, 400 mG, 4 G full scale*
<i>With A/m option:</i>	30 mA/meter, 300 mA/meter, 3 A/meter, 30 A/meter, 300 A/meter full scale*

*Multiply all values by 100 when using the optional X100 probe

<i>Accuracy:</i>	± 5% at calibration frequency
<i>Linearity:</i>	± 2% Full Scale
<i>Recorder Out Level:</i>	0 - 2.5 VDC, 25 : A maximum
<i>Recorder Out Jack:</i>	¼ inch stereo phone jack
<i>Battery:</i>	12 VDC, 1400 mA-h rechargeable Nickel-Cadmium (NiCd)
<i>Battery Life:</i>	Approximately 20 Hrs. continuous operation (full charge)
<i>Battery Charger:</i>	110/220 VAC, 16 hour
<i>Environmental Operating Temperature:</i>	0°C to 50°C (+32°F to +122°F)
<i>Humidity:</i>	5% to 95% relative humidity, noncondensing

Instrument Package:

Dimensions (Including connectors): 165 mm x 95 mm x 70 mm
(6.5 in x 3.75 in x 2.75 in)
Weight: 0.88 kg (31 oz)

Standard Probe:

Type: External, three-axis multi-turn loop
I. D. (each loop): 110 mm (4.33 in)
O. D. (each loop): 116 mm (4.57 in)
Area (each loop): 0.010 m² (15.5 in²)
Overall Diameter: 127 mm (5 in)
Handle Length: 292 mm (11.5 in)
Cable length: 1.5 meters (5 ft)
Weight: 0.45 kg (16 oz)

Optional X100 Probe:

Type: External, three-axis single-turn loop
Loop Dimension: 12.7 mm (.5 in) per side
Area (each loop): 6.35 mm² (.25 in²) per side
Overall Diameter: 34.3 mm (1.35 in)
Overall Length: 292 mm (11.5 in)
Cable length: 1.5 meters (5 ft)
Weight: 0.31 kg (11 oz)

3.0 ACCEPTANCE AND CONTROLS

Introduction

This section contains information on: unpacking and acceptance of the HI-3637; the battery; the battery charger, and; all controls, indicators and connectors (refer to figure 3-2 for the location of these components).

Unpacking and Acceptance

- Step 1. Upon delivery of your order, inspect the shipping container(s) for evidence of damage. Record any damage on the delivery receipt before signing. In case of concealed damage or loss, retain the packing materials for inspection by the carrier.
- Step 2. Remove the meter and probe from the shipping containers. Save the boxes and any protective packing materials for future use.
- Step 3. Check all materials against the packing list to verify that the equipment received matches that which was ordered. If you find any discrepancies, note them and call Holaday Customer Service for further instructions.

Be sure that you are satisfied with the contents of your order and the condition of your equipment before using the meter.

Battery

The 12 VDC, 1400 mA-h NiCd battery provides up to 20 hours of meter operation when fully charged.

Battery Charger

Refer to Figure 3-1 for the following step.

- Step 1. Check the viewing window on the power entry module to verify that the battery charger is set to the proper voltage for your AC power source. If not, change the setting via the following procedure: After ensuring that the charger is unplugged, use a small

screwdriver to pry loose the fuse assembly, which is located below the AC connector. Remove the assembly and locate the small PC Board on the back side. Slide the PC board from right to left to remove it from the fuse assembly: rotate this board so that the desired voltage indicator is right-side up, then reinsert it into the fuse assembly. The required voltage should now be visible in the viewing window. Firmly reseal the fuse assembly back into the power entry module. The charger is now ready to use. See section 4 for the battery charging procedure.

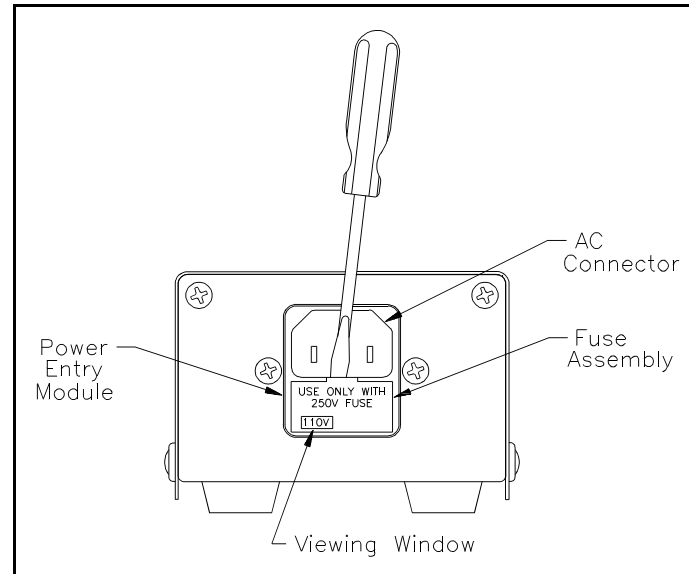

Figure 3-1
End View of Charger

NOTE:

If the correct voltage is still not visible, contact Holaday Customer Service for

assistance.

Controls, Indicators and Connectors

The instrumentation is housed in a rugged aluminum chassis. The entire unit is shipped in a convenient carrying case. The protective foam liner inside the carrying case has cutouts which accommodate the meter, the detachable probe and the optional accessories offered for the meter.

The probe consists of a sensing head containing three orthogonal coils oriented to pick up the X, Y, and Z components of the field. The detachable probe plugs into the multi-pin connector mounted on top of the chassis. The color coded label surrounding the probe connector will match the color of the band on the probe cover.

The top of the chassis also contains a ¼ inch stereo phone jack. The jack is used to connect the battery charger and also provide access to the recorder output signal.

The rotary selector switch on the HI-3637 front panel controls power to the instrument and selects one of five measurement ranges. The scales are arranged so that when turned to the first position—400 : T/4 G (or 300 Amps/meter if the optional kit is installed)—the meter is measuring on its least sensitive scale, i.e., highest range. As the switch is rotated clockwise, the sensitivity of the meter increases. As a general rule, readings will be most accurate when the meter movement shows maximum deflection without lighting the Over Range indicator.

There are two indicators on the front panel. A "Low Battery" LED illuminates when the battery voltage is too low to provide accurate readings. At this point, testing should be discontinued and the battery recharged or replaced. The "Over Range" LED illuminates when the measured flux density exceeds full scale for the selected range.

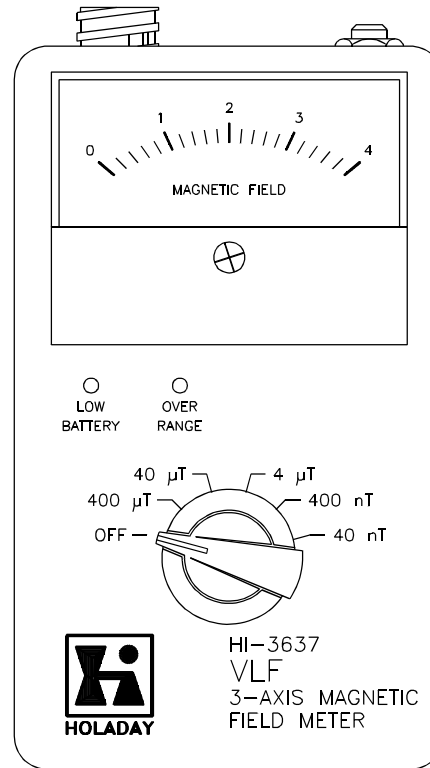

Figure 3-2
HI-3637 Front Panel

Recorder Output

The HI-3637 Magnetic Field Meter offers a recorder output. The recorder signal level is proportional to meter deflection, and varies between 0 and 2.5 VDC. This output signal can be used to drive a chart recorder, datalogger, or other device.

The recorder output is accessed through the battery

charger connector (refer to Figure 3–3). This is a two-conductor jack that mates with a standard ¼ inch stereo phone plug. The ring of the phone plug is reserved for battery charger input and the tip is connected to the recorder output. The shaft of the plug is common ground. A diode in the charging circuit isolates the battery voltage from the recorder output when the plug is inserted into the jack.

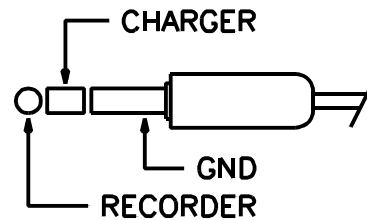

Figure 3–3
¼ inch Stereo Phone Plug

The same circuit drives both the meter movement and the recorder output. The maximum recorder output current is 25 microamperes, requiring a 100 K Ω minimum recorder output load; a lower impedance will affect the accuracy of both the meter reading and the recorder output voltage.

Both the meter movement and recorder output are driven by a (PWM) pulse-width modulated signal from the microprocessor. This leads to a small amount of ripple.

Low Battery Indication

The HI-3637 Magnetic Field Meter includes a "Low Battery" indicator (LED) mounted on the front panel (refer to Figure 3–2). It is normal for this LED to flash briefly when switching ranges and when turning the instrument off.

If the "Low Battery" indicator remains on during operation, the battery must be recharged. When the "Low Battery" LED lights, testing should be discontinued

and the battery recharged or replaced. This is due to the output characteristic of NiCd batteries: the voltage remains relatively constant until the battery is almost completely depleted, then drops very rapidly.

4.0 BATTERY CHARGING

Introduction

Each HI-3637 meter contains a rechargeable nickel-cadmium (NiCd) battery. A fully-charged battery (nominal output voltage of 12 VDC) provides up to 20 hours of operation.

NOTE:

Holaday Industries, Inc., charges the internal NiCd battery of the HI-3637 at the factory in order to calibrate the instrument prior to shipment. While every effort is made to ensure that your meter arrives ready to use, we cannot guarantee that this will be the case. Always check the condition of the meter's battery prior to use.

Battery Tips

Nickel-Cadmium (NiCd) batteries have several characteristics that can affect both their performance and operating life. The following tips advise you how to take advantage of these characteristics to get the most out of your meter's battery.

- Although NiCd batteries are rated for operation in temperatures from -20 °C to +65 °C (-4 °F to +140 °F), using the meter in extreme temperatures will reduce operating time significantly. The optimum operating temperature range for these batteries is +20 °C to +30 °C (+68 °F to +86 °F).
- The battery in the HI-3637 does not require periodic "deep discharges" to reverse the capacity-depleting "memory effect" caused by repeated shallow discharges; however, undercharging can reduce battery capacity.
- If the battery appears unable to acquire or maintain an appreciable charge, individual cells in the battery may be shorted or damaged. If, for any reason, you need assistance replacing your battery contact Holaday Customer Service.

Charging Procedure

- Step 1. Verify that the battery charger is set correctly for the AC voltage in your area.
- Step 2. Plug the charger into a suitable AC source.
- Step 3. Set the meter switch to OFF. Insert the plug on the charger cable into the meter's ¼ inch stereo phone jack. The indicator on the charger lights up only when the instrumentation/readout package is connected.

NOTE:

The rotary selector switch must be in the OFF position for the battery to charge.

- Step 4. The battery is now charging. This may take up to 16 hours, depending on how deeply the battery is discharged.

Charging Considerations

Recharge the battery using either the standard trickle charger or the optional quick charger (See Table 5-2). Recharging a fully discharged battery will take up to 16 hours with the trickle charger or one hour with the quick charger.

Charge time can be reduced only by increasing the charging current. If this higher current level is not monitored carefully and charging stopped at the proper time, the battery may be permanently damaged. Holaday Industries offers an optional one-hour quick charger, developed in cooperation with a NiCd cell manufacturer. This charger is microcomputer controlled and can safely recharge the NiCd battery (at the maximum rate) in one hour. It uses an algorithm to determine full charge, allowing a battery in any state of discharge to be brought to full capacity without overcharging.

There are a number of chargers available for this type of NiCd battery. Some do a very good job of charging the battery, others sacrifice battery life for decreased charge

time. The HI-3637 should be charged only with an approved battery charger.

Battery Replacement

A NiCd battery powers the HI-3637 Magnetic Field Meter (See Table 5-1). In the event of battery failure, a new battery can be obtained from Holaday Industries.

NOTE:

A #0 Phillips screwdriver works well for the following procedure.

To replace the battery, remove the eight screws located around the lip of the meter's front panel, pull the panel away from the chassis and unplug the battery connector. Remove the battery retainer and the old battery. Install the new battery and reverse the above steps to reassemble the meter.

CAUTION

Never short the terminals of a NiCd battery (even a discharged battery). The resulting current may be excessive and cause the lead wires to become extremely hot, which can result in severe burns and/or fire.

5.0 MAINTENANCE

Introduction

This section explains which maintenance tasks can be performed by the user. It also provides information regarding replacement and optional parts. If you have any questions concerning probe maintenance, consult Holaday Customer Service.

Maintenance Recommendations

Maintenance of the HI-3637 is limited to external components such as cables or connectors.

Any calibration or maintenance task which requires disassembly should be performed at the factory. Check with Holaday Customer Service (952-934-4920) before opening the unit as this may affect your warranty.

Return Procedures

To return an instrument to Holaday, use the following procedures:

- Step 1. Briefly describe the problem in writing. Give details regarding the observed symptom(s), and whether the problem is constant or intermittent in nature. If you have talked previously to Holaday Customer Service about the problem, provide the date(s), the name of the service representative you spoke with, and the nature of the conversation. Include the serial number of the item being returned.
- Step 2. Package the instrument carefully. Use the original carrying case, if possible. If not, use the Parts List in Table 5-1 to order a new case and foam packing from Holaday Industries, Inc.

NOTE:

If your meter is calibrated in accordance with MIL-Std-45662A, it is greatly to your benefit to retain the original shipping box and packing

materials. One of the criteria for certifying a calibration to MIL standards requires Holaday Industries to always ship equipment in the specified packaging. When a MIL Standard instrument is sent to Holaday in other packaging, we must replace it with the specified packaging materials for return shipment. YOU WILL BE BILLED FOR THE NEW PACKAGING.

If the instrument is under warranty, refer to the Limited Warranty at the front of this manual for additional information about your return.

Periodic/Preventive Maintenance

The HI-3637 requires an annual calibration check to verify that it is performing within specifications. This calibration check may be performed by Holaday Service Personnel at the factory. Return your meter(s), using the original packing materials (if possible), to:

**Holaday Industries Inc.
Attn. Service Department
14825 Martin Drive
Eden Prairie, MN USA 55344**

Parts Information

Use the tables below for ordering replacement (Table 5-1) or optional (Table 5-2) parts for the HI-3637.

Table 5-1. Replacement Parts List

Part Description (Replacement Parts)	Part Number
Battery, 12 VDC, Rechargeable	491069
Universal 12V Trickle Charger (110/220 Volt)	491063-05
Carrying Case	491085
HI-3637 User's Manual	600055

Table 5-2. Optional Parts List

Part Description (Optional Parts)	Part Number
X100 VLF Probe Assembly	491076
Amps/meter Kit	651006
Probe Mount	491050

6.0 MAKING MEASUREMENTS

Quick Start

For experienced users, or for those who particularly dislike reading operating descriptions, the following is a quick start procedure to get you up and running as soon as possible:

NOTE:

This meter uses the same probe connector as Holaday's HI-3627 ELF Magnetic Field Meter. Consequently, if you use both meters, it is possible to connect the probe from one meter to the instrumentation/readout package of the other meter, resulting in erroneous readings. To prevent this, color bands are placed on both the probe and the readout: on the probe, the color band surrounds the center of the spherical probe housing; on the readout, the color band surrounds the multi-pin connector at the top of the chassis. The colors used are orange (HI-3627) and yellow (HI-3637). When performing Step 1, below, **be sure the color band on the probe matches the color band on the instrumentation/readout package.**

- Step 1. Plug the probe into the multi-pin connector at top of the meter.
- Step 2. Turn the meter on by rotating the range selector switch one position clockwise.

NOTE:

The Battery Low LED will flash momentarily when the meter is turned on.

- Step 3. Verify that neither the Over Range nor Battery LEDs are illuminated.
- Step 4. Make measurements with the range selector switch set for the maximum reading without an over range indication.

NOTE:

The meter will not operate when the battery charger is connected to the charger jack.

Description

To begin making field measurements, connect the probe to the meter. Turn the range switch clockwise, increasing the instrument's sensitivity until an up-scale meter reading is obtained. Readings will be most accurate when the selected range yields maximum needle deflection without lighting the Over Range LED. When an over range indication occurs, select the next larger range. Since the meter movement is protected against deflection past the top of the meter scale, the "Over Range" LED must be used to determine an over range condition.

The probe utilizes three mutually-perpendicular concentric coils it is not necessary to rotate the sensor to obtain a maximum indication on the meter.

7.0 THEORY OF OPERATION

Introduction

The circuitry of the HI-3637 can be divided into seven sections: probe, range select, pre-filter, integrator, post-filter, RMS calculation and the power supply. Each of these is discussed in the follow sections (see Figure 7-1).

Probe

The probe consists of three orthogonal concentric shielded coils aligned such that their axes are mutually perpendicular. Each coil's electrostatic shield is isolated from that of the others: the shields are connected at a single point at the base of the sphere defined by the coils. The signal from each coil is routed to the meter through a shielded twisted-pair cable: this cable's shield is also connected to the common point of the coil electrostatic shields.

Range Select

The output voltage of a coil varies with the frequency of the applied magnetic field. In order to accommodate the magnetic field amplitudes and frequencies that the HI-3637 is designed to measure, a set of selectable attenuators is used to ensure that the input voltage to the remaining circuitry is at the proper level for the selected range.

Pre-filter Section

Each channel is filtered separately. A fourth-order high-pass Butterworth filter is used to insure that only signals with a frequency of 2000 Hz or greater reach the integrator. The Butterworth filter attenuates the signal by 3 dB at the cutoff frequency, has maximum attenuation in the stop band, and has no ripple in the passband.

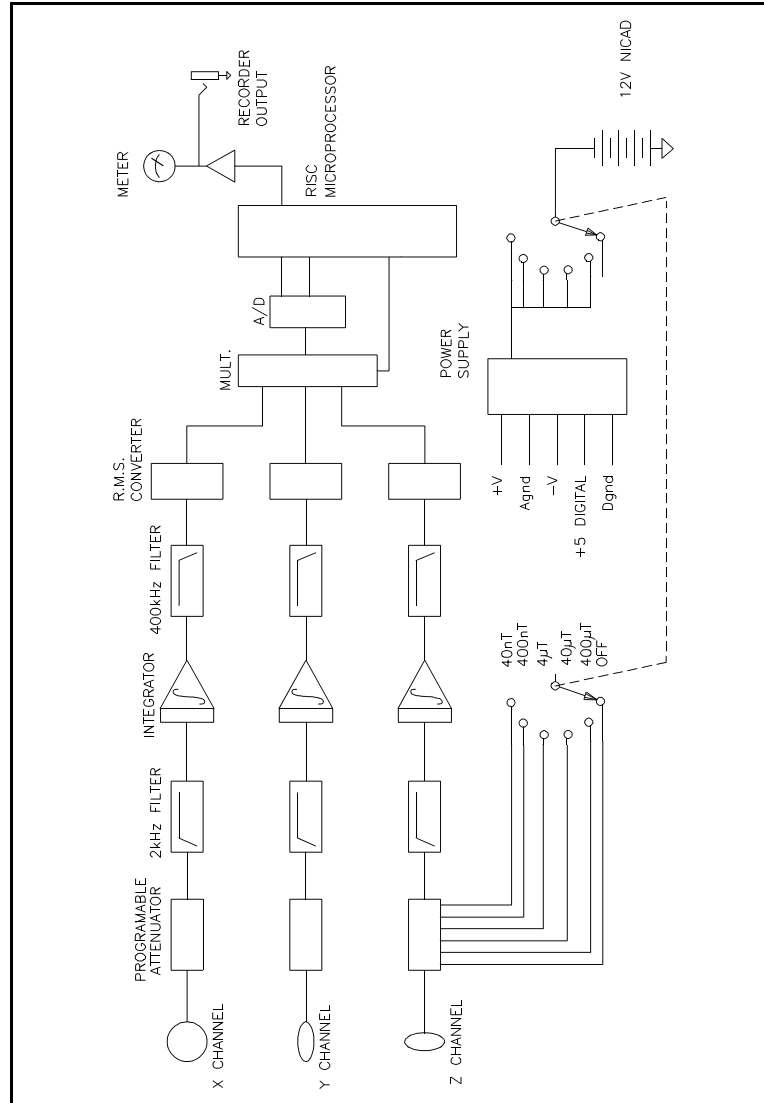

Figure 7-1
Block Diagram

Integrator Section

The output voltage of the probe sensor coils increases directly with the frequency of the applied magnetic field. The integrator provides a flat frequency response.

Post-filter Section

A second-order Butterworth low-pass filter ensures that only signals below 400 kHz are fed to the RMS calculation section.

RMS Calculation

The signal from each channel is applied to a separate true RMS converter and combined through vector addition to obtain the field magnitude. This value is computed by the processor and A/D converter. The meter is driven by outputs configured as a PWM (Pulse-Width Modulator). The processor performs an A/D conversion on each axis signal by programming the analog multiplexer, which feeds the A/D converter. The digital values are squared and summed; then the square root of the sum is calculated. This result determines the duty cycle of the PWM output, which drives the meter movement. The PWM output frequency is 30 Hz; this is too high to be visible on the analog meter, but it can be detected on the recorder output as approximately 50 mV of ripple.

Power supply

A ten-cell NiCd battery powers the HI-3637. The current consumption of the instrument is relatively low, yielding a continuous operating time of 20 hours. In typical daily operation (intermittent use), the operating time between charges will be much greater. The voltages required by the analog circuitry are derived directly from the battery voltage. The digital voltage is supplied via a series pass regulator.

8.0 CALIBRATION

The HI-3637 is calibrated using a Helmholtz coil (consisting of two close-coupled windings) one meter in diameter to establish an accurate, known magnetic field flux density. A precisely controlled and measured sinusoidal current is driven through the coils and, based on the dimensions of the coils, the magnetic field flux density between the coils is calculated.

Each axis is individually calibrated. Calibration is performed at a frequency of 20 kHz, and verified at 232 kHz, at a flux density level of 10 mG. The out of band response is checked at 60 Hz and 700 kHz. All calibration is traceable to NIST.

The HI-3637 indicates magnetic flux density (B) in units of Tesla/Gauss. The flux density in microteslas or the magnetic field strength (H) in milliamperes per meter are related as follows:

$$1 \text{ mG} = 0.1 \text{ microtesla (: T)}$$

$$1 \text{ mG} = 80 \text{ milliamperes per meter (mA/m)}$$

The recommended calibration interval is one year. Holaday Industries offers complete calibration services which comply with MIL-STD 45662A.

9.0 REFERENCES

⁽¹⁾ *IEEE Standard Procedures for Measurement of Power Frequency Electric and Magnetic Fields from AC Power Lines.* ANSI/IEEE standard 644-1987. Published by The Institute of Electrical and Electronics Engineers, Inc., 345 East 47th Street, New York, NY 10017. Approved November 17, 1986.

⁽²⁾ *Swedish National Board for Measurement and Testing, Test Methods for Visual Display Units—Visual Ergonomics and Emission Characteristics.* MPR 1990:8, 1990-12-01, National Board for Measurement and Testing, Box 878, S-501 15 Bors, Sweden.

⁽³⁾ *Electric and Magnetic Field Measurements and Possible Effects on Human Health from Appliances, Power Lines, and Other Common Sources.* Special Epidemiological Studies Program, California Department of Health Services, 2151 Berkeley Way, Room 704, Berkeley, Ca. 94704 (415) 540-2669

APPENDIX A VIDEO DISPLAY TERMINALS (VDTs)

VDT CHARACTERISTICS

General Description

Video display terminals (VDT's) and television receivers are quite similar in certain respects. Both are used to display information; the VDT displaying information received from a computer system, word processing system, or other digital information system and the television receiver displaying video information transmitted from television broadcast stations. In conjunction with a keyboard, the VDT serves as the main interface between the operator and a word processor, computer, etc. Television receivers are sometimes used in lieu of VDT's with home computer systems.

Principles of Operation

VDT's and television receivers use the same basic principles of operation. Both contain a large evacuated glass tube called a cathode-ray tube (CRT), or picture tube in the case of television receivers. The CRT contains a source of electrons (the cathode) at one end and a fluorescent coating on the inside of the viewing screen. Electrons released from the cathode are accelerated by a high voltage (typically in the range of 10 to 25 kilovolts) and are projected onto the fluorescent material of the screen which then emits visible light when it is struck by the fast-moving electrons. The CRT also includes various electrodes for focusing the electron beam and for scanning the beam across the fluorescent screen. Electronic circuitry in the VDT modulates the electron beam to produce the intended images on the screen. This circuitry leads to the production of electromagnetic fields (emissions). There are four basic aspects to the electrical environment of VDT emissions: (1) 60/50 Hz modulated DC fields; (2) 60/50 Hz fields; (3) RF fields associated with the horizontal and vertical deflection systems; (4) broadband RF fields caused by the digital electronic circuits which are associated with character generation (Roy, et al, 1983).

Modulated DC Fields

To accelerate the electron beam toward the screen, a high DC voltage is used. The high voltage is produced by pulsing a transformer which has a high turns ratio and is often derived from the deflection circuitry, though in some cases it may have a higher frequency depending on the character display system. The drive pulse is a square wave which produces a high voltage secondary pulse that is rich in harmonic content. The AC components of this DC current pulse flow to ground via the capacitance formed by the CRT screen and the resistive coating on the outside of the CRT. This small capacitance provides the filtering necessary for a smooth high voltage accelerating potential. Roy, et al, (1983) have reported that one method of reducing the AC component of the DC field is to place an RC filter network between the high voltage transformer output and the CRT. They found that such a filter could, in some VDT's, reduce the AC component of the DC field by as much as 50 dB (a factor of over 300 times).

The modulated DC field is produced by the charge on the face of the CRT and is largely confined to the front of the unit. This field is highly variable, being affected by humidity, capacitance between the CRT and external objects and touching the CRT (Harvey, 1984a). Several investigators have measured the strength of this DC field and found values ranging from a few hundred volts per meter to as high as 45 kV/m at the surface of the body of an operator, and depending on the proximity of the operator to the VDT, closer distances resulting in higher measured incident DC fields (Olsen, 1981; Harvey, 1984b; Nylén, et al, 1984; Bracken, et al, 1985).

60/50 Hz Fields

These fields are caused primarily by the current flowing in the vertical deflection coil and are nearly symmetrical around the coil. It is produced by the same mechanism that produces the DC field; the charge on the VDT screen which produces the DC field is actually not constant but builds up and decays by a small amount each time the display is scanned by the electron beam. This occurs at a nominal 60 Hz rate although harmonics may exist up to several kHz (Harvey, 1983a). Measurements of the 60 Hz emissions and harmonics by Stuchly, et al, (1983) found magnetic field strengths of 100 to 200 mA/m at a position 30 cm in front of the VDT. Harvey (1984b) reported measured 60 Hz AC electric field strengths of between 5 and 60 V/m in an investigation of five VDTs. These relatively low values are in the range of other commonly encountered 60 Hz appliances found in the home and office environment.

Deflection System Fields

The principal RF component of VDT emissions is caused by the so-called flyback transformer circuitry which is responsible for a rapidly changing current which flows in the horizontal deflection coils of the VDT and causes the electron beam to be rapidly swept to the left side of the screen, ready for another trace across the screen. The rate at which the electron beam is scanned is dependent on the particular design of the VDT but typically falls in the range of 17 to 30 kHz. For television receivers, the flyback frequency is approximately 15.75 kHz.

The flyback circuit is rich in harmonic production and any instrument intended for accurate assessment of RF exposure fields produced by VDT's must be capable of true RMS measurement. The strong harmonic content of the flyback signal means that it has a non-sinusoidal waveform; the HI-3637 incorporates a true RMS detector circuit which can accurately respond to the complex waveforms observed near VDT's. Approximately 95 percent of the total energy of the flyback circuit emissions is contained within the first five or six harmonics. Consequently, the bandpass of the HI-3637 has been tailored to the necessary frequency range

to capture all the important harmonics.

In addition to the horizontal sweep-frequency circuit, there is a vertical deflection circuit which is used to deflect the electron beam down the CRT screen and in so doing produce characters. The vertical sweep frequency is approximately 60 Hz.

The horizontal deflection circuit operates on the principle that the force exerted on a moving electron is at right angles to both the direction of the electron's motion and the applied magnetic field. To induce a horizontal component to the electron's original direction, the magnetic field must possess a vertical polarization. Thus, the horizontal deflection coils in VDT's and television receivers tend to generate magnetic fields which are strongly vertically polarized near the front of the screen.

RF fields caused by the deflection circuitry can produce electric fields at normal operator positions of typically a few V/m up to some tens of V/m and magnetic fields in the range of a few mA/m up to several hundred mA/m (Harvey, 1983b; Guy, 1987; Boivin, 1986; Joyner, et al, 1984; Marha and Charron, 1983). The HI-3637 is designed specifically for measurement of the RF fields associated with the beam deflection systems in VDT's and television receivers.

Broadband RF Fields

An electronic clock within the VDT which typically operates in the frequency range of 1 to 20 MHz is the source of most of the radiated RF signals from the digital electronics sub-section (Roy, et al, 1983). Conventional shielding techniques are the usual method for eliminating or reducing such emissions. Petersen, et al, (1980) and Weiss and Petersen (1979) evaluated RF emissions from a number of VDT's and found that RF electric field strengths, measured at a distance of 1.5 meters from the front of the VDT, for those emissions not associated with the flyback circuit were well below 1 V/m RMS, typically less than 0.01 V/m.

CHARACTERIZING VDT EMISSIONS AND OPERATOR EXPOSURE

Introduction

Because of the perturbing influence of the measured electric field strength values near VDT's, it is important to distinguish between assessments of operator exposure and basic emission characteristics of VDT's. Relative to electric fields, these two properties are not the same.

Characterizing VDT Emissions

On occasion it is desirable to characterize the electromagnetic emissions of a number of VDT's, such as in a large office situation, to establish the general emission levels of these VDT's for comparison with other VDT emission data. Such measurements can be used to determine unusual operating characteristics of particular VDT's within a group. To collect this type of data, it is helpful to minimize unnecessary, extraneous environmental factors.

Emission characterizations should therefore be performed without the operator present. Although the literature contains numerous methods by which emission data have been obtained, the principal difference lies in the locations about the VDT at which measurements are performed. An exploration of the surfaces of a typical VDT will reveal areas of particularly intense fields, but these areas are usually on the sides or top of the VDT and are not directly applicable to frontal area exposure where the operator would be positioned. Because of this, a nearly universal measurement location—positioned at a point 30 cm directly in front of the VDT screen—has been commonly used and recommended in emission characterizations (FDA, 1984).

Measurement distances of 50 cm and 1 m have also been used. The value of 30 cm actually represents a quite close distance when compared to the viewing distance used by many VDT operators. In fact, a minimum viewing distance closer to 36 cm has been recommended (Diffrient, et al, 1981). Nevertheless, because the value of 30 cm has been so often reported in the literature,

measurements should at least include this distance among possible others.

VDT emission data reported in the literature show that in most instances a fixed screen condition has been used to promote more repeatable measurements. For example, a commonly reported method involves filling the screen with a single character such as an E or M and adjusting the brightness and contrast controls to their maximum position. In contrast to these precautions, it has also been reported that these measures often seem to have very little, if any, impact on the resulting measured values of electric and magnetic field strength (Roy, et al, 1983). Nevertheless, because of peculiarities of some VDTs, a check of the effect of varying the brightness and contrast controls should be made. Roy, et al (1983), suggest that CRT performance, which decreases with age, and the type of video generating system used are two possible factors responsible for this phenomenon.

Measurements of the magnetic field strength are considerably less difficult since the presence of the human body does not perturb the magnetic field.

Distances are measured between the screen surface and the center of the probe for magnetic field values. As the distance between the probe and the screen is decreased, greater error will exist in the indicated value of magnetic field strength. This spatial averaging error diminishes rapidly with distance from the VDT since the field rapidly becomes more uniform.

Because the magnetic field gradients are so great near the VDT, significant error may occur if extra care is not exercised when attempting repeated measurements at a specific location. This is apparent when holding the instrument without a tripod very near the screen and attempting to obtain a constant reading of field strength.

GUIDELINES FOR RF EXPOSURE

To provide a means for judging the significance of measured magnetic field emissions found near VDT's, the scientific literature can be examined for information on suggested exposure or emission limits. The exposure standards reviewed at the time of this manual's preparation apply to humans for the purpose of establishing safe working or living environments where magnetic fields exist. The exposure limits compiled in this manual are those found that correspond most closely to the predominant frequency range of VDT's. In some cases, the standards apply to occupational exposure environments and in other cases, to the general living environment; often standards for this latter case are referred to as general population or public exposure limits.

Traditional approaches to radiation protection, principally derived from ionizing radiation protection practices, usually differentiate between occupational and public exposure. Generally, occupational exposure limits are higher, i.e., more permissive, than public limits. This is because of the greater uncertainties associated with the general public; in the work place, employees are generally healthier, and possible exposure to potentially hazardous physical agents is usually under much better control. For example, employers can inform workers of situations which should be avoided; this is not the case for the general population. Regardless of these considerations, it is informative to examine some of the recommended exposure guides that apply to different organizations and/or countries.

Table 1 summarizes the electromagnetic field exposure standards found in the literature that either directly apply to the frequency range appropriate to VDT emissions or pertain to a frequency range close to that of interest. As can be seen, the primary difficulty in applying many RF exposure standards to VDT emission levels is that the applicable frequency range of the standards does not extend low enough. From the literature searched, only one reference was found that offered a quantitative emission limit as a guideline specific to VDT's (Telecom,

1984). This Occupational Health Policy Guideline for VDT screen-based equipment was developed by Telecom Australia for internal use until such time as there is a national standard for VDTs in Australia. The guide specifies that the levels of radiation emitted from cathode-ray VDT's in the frequency range of 50 Hz to 0.3 MHz shall be as low as possible, and should not, at any time, exceed an electric field strength of 50 V/m, measured 30 cm from the terminal.

The reader of this manual is cautioned that a number of RF exposure standards are presently under development or revision and that Table 1 should be used more as an orientation to existing standards.

Table 1.
Radio Frequency Exposure/Emission Standards Pertinent to
the VDT Frequency Range.

<u>Standard/Reference</u>	<u>Frequency (kHz)</u>	<u>E (V/m) RMS</u>	<u>H (gauss) RMS</u>
ACGIH	0) 0.1	25000	---
	0.1) 4	$2500/f^{(1)}$	$0.6/f^{(1)}$
	4) 30	625	---
IEEE C95.1	3) 100	614	2.05
IRPA (gen. pop. 24 hr.)	50/60 (Hz)	5000	1.0
Swedish Guidelines ⁽²⁾	.005) 2	25	.0025
	2) 400	2.5	.00025
UK(1986)(occ)	750 Hz - 50 kHz	2,000	1.25
UK(1986)(public)	750 Hz - 50 kHz	800	.05
USSR(public) (Slesin, 1985)	0.03 - 0.3	25	---

⁽¹⁾ Frequency in KHz

⁽²⁾ These guidelines are not based on biological effects.
They are based on what was technically possible.

-- NOTES --