

CPU Modules CPU001 and CPU002

June 2010

GFK-1536R

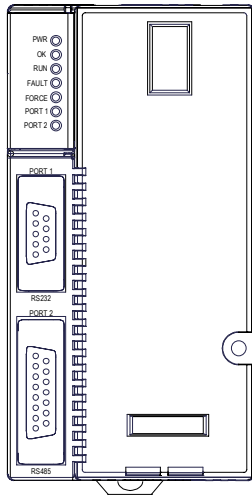

Features

- Non-volatile flash memory for program storage
- Programming in Ladder Diagram and Instruction List
- Battery backup for program, data, and time of day clock
 - Super capacitor provides power to memory for 1 hour
 - Over 1 hour, backup battery protects memory contents up to 6 months.
 - Backup battery has shelf life of 5 years when not in use.
- Run/Stop switch
- Floating point (real) data functions
- Embedded RS-232 and RS-485 communications
- Supports EZ Program Store device (IC200ACC003)
- 70mm height when mounted on DIN rail with power supply

Specifications

Size	2.63" (66.8mm) x 5.04" (128mm)
I/O Discrete Points	2048 In, 2048 Out
Discrete Internal Bits	1024 points
Discrete Temporary Bits	256 points
Global Discrete Bits	1280 points
Configurable Memory (Program, Registers, I/O Analog Words)	CPU001: 34K bytes maximum CPU002: 42K bytes maximum
Boolean execution speed	1.8ms/K (typical)
Floating Point	Yes
Override	Yes
Built-in ports	RS-232, RS-485
Built-in communications	SNP Slave, RTU Slave, Serial I/O
Type of memory storage	System flash, battery-backed RAM
Battery-Backed Real-time Clock	Yes
Realtime clock accuracy (for timers or timer contacts)	100ppm (0.01%) or +/- 9sec/day
Time-of-day clock accuracy	23ppm (.0023%) or +/- 2sec/day @ 30C; 100 ppm ((0.01%) or +/- 9sec/day @ full temperature range.

Product Revision History

Rev	FW version	Description / Features
CPU001-HK	2.35	Hardware part change.
CPU001-GK CPU002-EG	2.35	Corrections to PID function block, serial communications, and EZ Program Store device features.
CPU001-FJ CPU002-DF	2.34	Support for 32-bit Modbus registers, updated PID function block, higher serial communications throughput
CPU001-DH CPU002-BE	2.31	Support for Modbus® RTU Master
CPU001-DG CPU002-BD	2.30	Added support for Modbus® RTU Master
CPU001-DF CPU002-BC	2.20	Added new serial I/O baud rates
CPU001-DE CPU002-BB	2.10	Hardware-only upgrade to enhance manufacturability.
CPU001-CE CPU002-AB	2.10	Support for configurable memory, EZ Program Store Device, High-density Analog I/O modules, and RTS delay functionality for RTU and Serial I/O communications.
CPU001-CD CPU002-AA	1.50	Support for CPU002 and expansion I/O.
CPU001-BD	1.50	New Release 1.50 firmware loaded onto CPU001-BC hardware. Support for expansion I/O.
CPU001-CC	1.20	Hardware-only upgrade to support future functionality. No customer/user impact for changes made from -BC version.
CPU001-BC	1.20	Added support for ALG240, 331, 620, and 630 intelligent analog modules.
CPU001-BB	1.10	Added function blocks to scale input data. Added Drum Sequencer function block.
CPU001-BA	1.00	Updated hardware to support Intelligent I/O modules
CPU001-AA	1.00	Initial Product Release

Release 2.35 firmware replaces firmware version 2.10 through 2.34. The following CPUs can be upgraded to the new firmware version:

- CPU001 versions CC and later
- CPU002: all versions

The following CPUs cannot be upgraded. To use the new features of this release, new CPU hardware must be purchased:

- CPU001 versions AA, AB, BA, BB, BC, BD

If you need to determine the current firmware version of a CPU, see the steps below:

- With Machine Edition Logic Developer, go online to the CPU, then select Target > Online Commands > Show Status. The Device Information Software Revision shows the current firmware revision level.
- With a VersaPro or Control programmer, attach the CPU. Under the PLC menu (VersaPro) or the Comm menu (Control), select the Memory tab on the Status Information dialog.

A firmware upgrade is optional. Upgrading is recommended for applications that use PID function blocks or serial communications. An upgrade can be downloaded from www.ge-ip.com. (For CPU001: 44A747796-G09. For CPU002: 44A751403-G06). The firmware resides in FLASH memory, and is upgraded by serial download from a Windows PC via CPU port 1. Port 2 cannot be used for a firmware upgrade.

CPU Modules CPU001 and CPU002

September 2006

GFK-1536R

New for Release 2.35

1. PID Function Block: An optional filter for the Derivative Term has been added in version 2.34. This filter improves PID control loop stability by limiting the contributions of random variations and step input changes in the Set Point and Process Variable inputs. For more information, see the last page of this datasheet.
2. Higher Serial Communications Throughput: Serial communications throughput can be improved in version 2.34 by configuring the CPU for Constant Sweep Mode and specifying a sweep time that is significantly longer than the application's Normal Mode sweep time. Ethernet, backplane and serial communications now share the available time at the end of constant sweeps.
3. Support for 32-bit register data to the Modbus RTU master serial protocol. This feature was previously available in IC200CPU05 version 2.32. See the document GFK-2220, *Modbus RTU Master Communications*, which is available at www.ge-ip.com for information on using Modbus RTU Master communications. This document is a supplement to GFK-0582, the *Serial Communications User's Manual*.

Product Information

Revision:	CPU001-HK, CPU002-EG														
Firmware:	Version 2.35														
Compatibility, for configuring or using new features:	Machine Edition Logic Developer version 2.11 or later. VersaPro software version 1.0 or later for configuration, 1.5 or later to use new features. Control software version 2.20 or later.														
Expansion I/O Compatibility:	All types of I/O and communications modules can be used in expansion racks. Some analog modules require specific module revisions in expansion racks, as listed below: <table border="1"> <thead> <tr> <th>Module</th> <th>Module Revision</th> </tr> </thead> <tbody> <tr> <td>*ALG320</td> <td>B or later</td> </tr> <tr> <td>*ALG321</td> <td>B or later</td> </tr> <tr> <td>*ALG322</td> <td>B or later</td> </tr> <tr> <td>*ALG430</td> <td>C or later</td> </tr> <tr> <td>*ALG431</td> <td>C or later</td> </tr> <tr> <td>*ALG432</td> <td>B or later</td> </tr> </tbody> </table>	Module	Module Revision	*ALG320	B or later	*ALG321	B or later	*ALG322	B or later	*ALG430	C or later	*ALG431	C or later	*ALG432	B or later
Module	Module Revision														
*ALG320	B or later														
*ALG321	B or later														
*ALG322	B or later														
*ALG430	C or later														
*ALG431	C or later														
*ALG432	B or later														

Resolved for this Release

1. Using repeated port setup COMMREQs to alternate between SNP slave and Serial I/O protocols will not cause a CPU Software fault.
2. Setting both ERROR_TERM_SELECT (bit 3) and DERIVATIVE_ACTION (bit 0) in the Config Word (Address +12 of the Reference Array) no longer reverses the sign of the PID derivative term.
3. Changing the Integral Rate (Ki) parameter value of a PID function block from 2 to 1 (that is, from 0.002 to 0.001 Repeats/Sec.) or from 1 to 2 does not cause a step change to the Integral Term and the Control Variable.
4. When Serial I/O and Hardware Flow Control are specified for Port 2 in the hardware configuration, transmissions from port 2 will complete properly.
5. Using a Serial Port Setup COMMREQ to switch from one serial communications protocol to another will not cause a Corrupted User Memory Fault in the PLC Fault Table

6. Storing a new version of the application program and configuration using an EZ Program Store device will no longer fail when OEM protection is enabled.
7. When a serial port is configured for either SNP or SNP-X and a character with a framing error is received on either serial port, the port continues responding to received characters.

Operating Notes/Restrictions

1. When a serial port is configured for either Modbus RTU (slave or master) or Serial I/O, and a parity, framing or over-run error occurs while a serial message is being received, the next message received is ignored.
2. When a serial port is configured for Modbus RTU slave, an SNP master device (for example, a serial programmer or HMI/SCADA device that uses the SNP protocol) may attach to the port. If the SNP device is disconnected and then an RTU query is sent to the port before 10 seconds have elapsed, the port is unable to receive any serial messages. To recover, power to the CPU must be turned off and then on.
3. When a serial port is configured for Serial I/O, and a new hardware configuration is stored that changes the port protocol to SNP, the port may not respond to SNP Attach messages until the CPU is powered off and then on.
4. In series 90-30 CPUs, the Shift Register Bit (SHIFR_BIT) instruction may be used to rotate a bit sequence around a range of discrete references by specifying the same reference for the output, Q, and the start reference, ST.

However, in VersaMax CPUs, separate references must be used for ST and Q, and additional logic must be used to copy the output bit from the Q reference to the ST reference.
5. When the configured size of a reference table is changed after the table is stored to flash memory, and the user attempts to read Initial/Forced Values from flash memory, the table will be filled with zeros.
6. Using an older revision non-intelligent analog module in an expansion rack causes a System Configuration Mismatch error to be logged. The faulted module must be replaced with a newer revision before it will be scanned. The allowed revisions are detailed under Compatibility, in the Product Information section, above.
7. Changing an IND or ISA PID function block integral rate parameter value from 1 (that is, from 0.001 repeats/sec.) to 0 or from 0 to 1 causes a step change in both the integral term and the control variable (CV) output. This result is expected. A zero integral rate value specifies that the integral term contribution to CV is zero, while a non-zero value specifies a non-zero contribution.
8. If the receiver in a local single rack is powered off while the CPU is powered on, erroneous 'Addition of rack' faults may be logged by the CPU. It is recommended that both the CPU and the receiver be powered by a single source.
9. Occasionally, a "Backplane Communication Fault" may be logged on an intelligent I/O module after power-cycling the main or expansion rack. This is a diagnostic fault that can be cleared.
10. In very rare instances, when field power is lost on one module, non-intelligent modules in the same rack may also report faults.
11. In very rare instances, the CPU may not add a module being hot inserted. It will not generate an 'Addition of Module' fault, and the module will not be scanned. The situation can be corrected by extracting and re-inserting the module.
12. In very rare instances, a module being hot inserted may cause analog modules in the same rack to set outputs to zero. In addition, 'Loss of Module', 'System Configuration Mismatch', or field faults may be generated on other modules in the same rack. If the modules do not return to correct behavior momentarily, power cycling will restore full operation.

CPU Modules CPU001 and CPU002

September 2006

GFK-1536R

Module Installation

This equipment may be mounted on a horizontal or vertical DIN rail. If mounted on a vertical DIN rail, the CPU module must be located at the bottom. The CPU and connecting carriers must be installed on the same section of 35mm x 7.5mm DIN rail, 1mm thick. Steel DIN rail is recommended. The DIN rail must be electrically grounded to provide EMC protection. The rail must have a conductive (unpainted) corrosion-resistant finish. DIN rails compliant with DIN EN50022 are preferred. For vibration resistance, the DIN rail should be installed on a panel using screws spaced approximately 15.24cm (6 inches) apart.

Rated thermal specifications for the CPU module are based on a clearance of 2" above and below the equipment and 1" to the left of the CPU module.

1. Allow sufficient finger clearance for opening CPU door.
2. Allow adequate clearance for serial port and Ethernet cables.
3. Allow adequate space for power wiring.

The CPU with power supply attached fits into a 70mm deep enclosure.

Installing the CPU on the DIN Rail

The CPU snaps easily onto the DIN rail. No tools are required for mounting or grounding to the DIN rail.

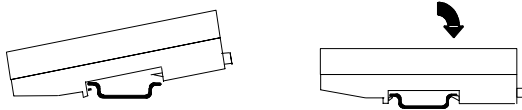

Before joining module carriers to the CPU, remove the connector cover on the right-hand side of the CPU. Do not discard this cover, you will need to install it on the last carrier, to protect the connector pins from contamination and damage during use.

Panel-Mounting

If excessive vibration is a factor the CPU should also be screwed down to the mounting panel.

Note 1. Tolerances are +/- 0.13mm (0.005in) non-cumulative.

Note 2. 1.1-1.4Nm (10-12 in/lbs) of torque should be applied to M3.5 (#6-32) steel screw threaded into material containing internal threads and having a minimum thickness of 2.4mm (0.093in).

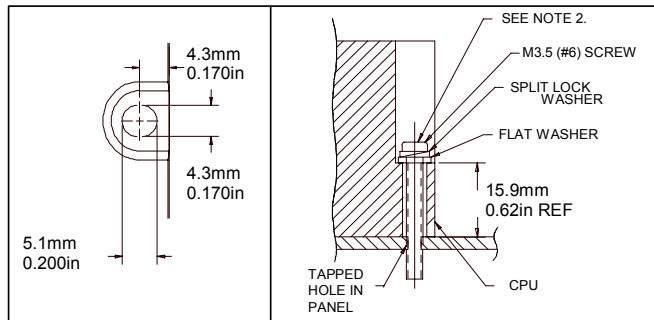

Removing the CPU from the DIN Rail

1. Turn off power to the power supply.
2. (If the CPU is attached to the panel with a screw) remove the power supply module. Remove the panel-mount screw.
3. Slide the CPU away from the other modules until the connector on the right side disengages from the next carrier.
4. With a small flathead screwdriver, pull the DIN rail latch outward while tilting the other end of the module down to disengage it from the DIN rail.

Activating or Replacing the Backup Battery

The CPU is shipped with a battery already installed. The battery holder is located in the top side of the CPU module. Before the first use, activate the battery by pulling and removing the insulator tab.

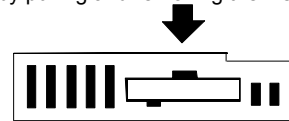

To replace the battery, use a small screwdriver to gently pry open the battery holder. Replace battery only with ACC001 from your PLC supplier, or with Panasonic battery: BR2032. Use of another battery may present a risk of fire or explosion.

Caution

Battery may explode if mistreated.

Do not recharge, disassemble, heat above 100 deg.C (212 deg.F) or incinerate.

Switching the PLC Operating Mode

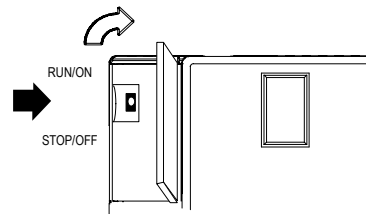

The CPU Run/Stop mode switch is located behind the module door. This switch can be used to place the CPU in Stop or Run mode. By default, Run/Stop mode operation is enabled. The same switch can also be configured to prevent writing to program or configuration memory and forcing or overriding discrete data. It defaults to disabled memory protection.

If Run/Stop mode switch operation is enabled, the switch can be used to place the CPU in Run mode.

If the CPU has non-fatal faults and is not in Stop/Fault mode, placing the switch in Run position causes the CPU to go to Run mode. Faults are NOT cleared.

If the CPU has fatal faults and is in Stop/Fault mode, placing the switch in Run position causes the Run LED to blink for 5 seconds. While the Run LED is blinking, the CPU switch can be used to clear the fault table and put the CPU in Run mode. After the switch has been in Run position for at least 1/2 second, move it to Stop position for at least 1/2 second. Then move it back to Run position. The faults are cleared and the CPU goes to Run mode. The LED stops blinking and stays on. This can be repeated if necessary.

If the switch is not toggled, after 5 seconds the Run LED goes off and the CPU remains in Stop/Fault mode. Faults stay in the fault table.

CPU Modules CPU001 and CPU002

September 2006

GFK-1536R

Observing the Module LEDs

PWR		The LEDs indicate the presence of power and show the operating mode and status of the CPU.
OK		
RUN		
FAULT		
FORCE		
PORT 1		
PORT 2		
POWER		ON when the CPU is receiving 5V power from the power supply. Does not indicate the status of the 3.3V power output.
OK		ON indicates the CPU has passed its powerup diagnostics and is functioning properly. OFF indicates a CPU problem. Fast blinking indicates the CPU is running its powerup diagnostics. Slow blinking indicates the CPU is configuring I/O modules. Simultaneous blinking of this LED and the green Run LED indicates the CPU is in boot mode and is waiting for a firmware download through port 1.
RUN		Green when the CPU is in Run mode. Amber indicates the CPU is in Stop/IO Scan mode. If this LED is OFF but OK is ON, the CPU is in Stop/No IO Scan mode.
		If RUN is flashing green and the Fault LED is ON, the Run/Stop switch was moved to Run position while a fatal fault existed.
FAULT		ON if the CPU is in Stop/Faulted mode because a fatal fault has occurred. To turn off the Fault LED, clear both the I/O Fault Table and the PLC Fault Table. If this LED is blinking and the OK LED is OFF, a fatal fault has occurred during self-diagnostics. Please contact PLC Product Support.
FORCE		ON if an override is active on a bit reference.
PORT 1 & 2		Blinking indicates activity on that port.

Using the CPU Serial Ports

The CPU's two serial ports are software-configurable for SNP slave, RTU slave, or Serial I/O operation. If a port is being used for RTU, it automatically switches to SNP slave mode if necessary. Both ports' default configuration is SNP slave mode. If configured for Serial I/O, a port automatically reverts to SNP slave when the CPU is in Stop mode.

Either port can be software-configured to set up communications between the CPU and various serial devices. An external device can obtain power from Port 2 if it requires 100mA or less at 5VDC.

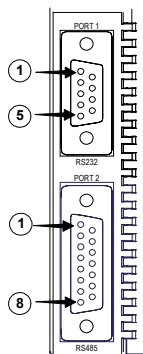

Port 1 is an RS-232 port with a 9-pin female D-sub connector. It is used as the boot loader port for upgrading the CPU firmware. The pinout of port 1 allows a simple, straight-through cable to connect with a standard AT-style RS-232 port. Cable shielding attaches to the shell. Port 1 screw locks are threaded #4-40.

Port 2 is an RS-485 port with a 15-pin female D-sub connector. This can be attached directly to an RS-485 to RS-232 adapter (IC690ACC901). Port 2 can be used for program, configuration, and table updates with the EZ Program Store module. Port 2 screw locks are threaded (metric) M3x0.5).

Pin Assignments for Port 1

Pin	Signal	Direction	Function
1	n/c		--
2	TXD	Output	Transmit Data output
3	RXD	Input	Receive Data input
4	n/c		--
5	GND	--	0V/GND signal reference
6	n/c		--
7	CTS	Input	Clear to Send input
8	RTS	Output	Request to Send output
9	n/c		--
Shell	SHLD	--	Cable Shield wire connection / 100% (Continuous) shielding cable shield connection

Cable Diagram for Attachment to a PC

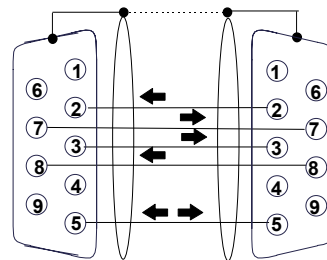

PC 9-Pin Serial Port	CPU Port 1
9-pin female	9-pin male
(2) RXD	(2) TXD
(3) TXD	(3) RXD
(5) GND	(5) GND
(7) RTS	(7) CTS
(8) CTS	(8) RTS

The shield must attach to shell of connectors on both ends of the cable.

Connector and Cable Specifications for Port 1

Vendor Part numbers below are provided for reference only. Any part that meets the same specification can be used.

Cable: Belden 9610	Computer cable, overall braid over foil shield 5 conductor † 30 Volt / 80°C (176°F) 24 AWG tinned copper, 7x32 stranding			
9 Pin Male Connector:	Type: Crimp	Vendor: ITT/Cannon AMP	Plug: DEA9PK87F0 205204-1	Pin: 030-2487-017 66506-9
	Solder	ITT/Cannon AMP	ZDE9P 747904-2	-- --
Connector Shell:	Kit* – ITT Cannon DE121073-54 [9-pin size backshell kit]: Metal-Plated Plastic (Plastic with Nickel over Copper) † Cable Grounding Clamp (included) 40° cable exit design to maintain low-profile installation Plus – ITT Cannon 250-8501-010 [Extended Jackscrew]: Threaded with #4-40 for secure attachment to port † Order Qty 2 for each cable shell ordered			

† Critical Information – any other part selected should meet or exceed this criteria.
* Use of this kit maintains the 70mm installed depth.

CPU Modules CPU001 and CPU002

September 2006

GFK-1536R

Pin Assignments for Port 2

Pin	Signal	Direction	Function
1	SHLD	--	Cable Shield Drain wire connection
2, 3, 4	n/c		--
5	P5V	Output	+5.1VDC to power external level converters (100mA max.)
6	RTSA	Output	Request to Send (A) output
7	GND	--	0V/GND reference signal
8	CTSB'	Input	Clear to Send (B) input
9	RT	--	Resistor Termination (120 ohm) for RDA'
10	RDA'	Input	Receive Data (A) input
11	RDB'	Input	Receive Data (B) input
12	SDA	Output	Transmit Data (A) output
13	SDB	Output	Transmit Data (B) output
14	RTSB	Output	Request to Send (B) output
15	CTSA'	Input	Clear to Send (A) input
Shell	SHLD	--	Cable Shield wire connection / 100% (Continuous) shielding cable shield connection

Connector and Cable Specifications for Port 2

Vendor Part numbers below are provided for reference only. Any part that meets the same specification can be used.

Cable: Belden 8105	Low Capacitance Computer cable, overall braid over foil shield 5 Twisted-pairs † Shield Drain Wire † 30 Volt / 80°C (176°F) 24 AWG tinned copper, 7x32 stranding Velocity of Propagation = 78% Nominal Impedance = 100Ω †			
15 Pin Male Connector:	Type:	Vendor:	Plug:	Pin:
	Crimp	ITT/Cannon AMP	DAA15PK87F0 205206-1	030-2487-017 66506-9
	Solder	ITT/Cannon AMP	ZDA15P 747908-2	-- --
Connector Shell:	Kit*-- ITT Cannon DA121073-50 [15-pin size backshell kit]: Metal-Plated Plastic (Plastic with Nickel over Copper) † Cable Grounding Clamp (included) 40° cable exit design to maintain low-profile installation Plus -- ITT Cannon 250-8501-009 [Extended Jackscrew]: Threaded with (metric) M3x0.5 for secure attachment † Order Qty 2 for each cable shell ordered			

† Critical Information -- any other part selected should meet or exceed this criteria.

* Use of this kit maintains the 70mm installed depth.

Cable Lengths

Maximum cable lengths the total number of feet from the CPU to the last device attached to the cable are:

Port 1 (RS-232) = 15 meters (50 ft.)

Port 2 (RS-485) = 1200 meters (4000 ft.)

Serial Port Baud Rates

	Port 1	Port 2
RTU protocol	1200, 2400, 4800, 9600, 19.2K	1200, 2400, 4800, 9600, 19.2K
Serial I/O protocol	1200, 2400, 4800, 9600, 19.2K	1200, 2400, 4800, 9600, 19.2K
SNP protocol	4800, 9600, 19.2K, 38.4K*	4800, 9600, 19.2K, 38.4K*

* Only available on one port at a time.

CPU Modules CPU001 and CPU002

September 2006

GFK-1536R

PID Function Parameter Block

In chapter 14 of the VersaMax PLC User's Manual, GFK-1503C, the table showing the Parameter Block for the PID function should be modified as described below.

For Address +12 (Config Word), the three rightmost columns are now:

Low Bit Units	Range	Description
Low 6 bits used		<p>The low 6 bits of this word are used to modify six default PID settings. The 10 high-order bits should be set to 0.</p> <p>Set the low bit (bit 0) to 1 to modify the standard PID Error Term from the normal (SP - PV) to (PV - SP), reversing the sign of the feedback term. This is for Reverse Acting controls where the CV must go down when the PV goes up.</p> <p>Set the second bit (bit 1) to 1 to invert the Output Polarity so that CV is the negative of the PID output rather than the normal positive value.</p> <p>Set the third bit (bit 2) to 1 to modify the Derivative Action from using the normal change in the Error term to the change in the PV feedback term.</p> <p>Set the fourth bit (bit 3) to activate deadband processing.</p> <p>Set the fifth bit (bit 4) to activate anti-reset-windup action.</p> <p>Set the sixth bit (bit 5) to activate derivative filtering.</p> <p>The low 6 bits in the Config Word are defined in detail below:</p>
Bit 0: Error Term +/-		<p>When bit 0 is 0, Error Term = SP - PV.</p> <p>When bit 0 is 1, eError tTerm = PV - SP.</p>
Bit 1: Output Polarity		When bit 1 is 0, the CV output represents the output of the PID calculation. When bit 1 is set to 1, the CV output represents the negative of output of the PID calculation.
Bit 2: Derivative action on PV		When bit 2 is 0, the derivative action is applied to the error term. When bit 2 is 1, the derivative action is applied to PV.

(table continued)...

Bit 3: Deadband action	<p>When bit 3 is 0, no deadband action occurs. If the error is within the deadband limits, then the error term is set to zero. Otherwise the error term is not affected by the deadband limits.</p> <p>If bit 3 is 1, deadband action occurs. If the error term is within the deadband limits, then the error is forced to zero. If, however, the error term is outside the deadband limits, then the error term is reduced by the deadband limit: Error Term = Error Term - deadband limit. A similar adjustment occurs when the error term is less than the lower deadband limit.</p>
Bit 4: Anti-reset-windup action	<p>When bit 4 is 0, the anti-reset-windup action uses a reset back-calculation. When the output is clamped, this replaces the accumulated Y remainder value with whatever value is necessary to produce the clamped output exactly.</p> <p>When bit 4 is 1, the accumulated Y term is replaced by the value of the Y term at the start of the calculation. In this way, the pre-clamp Y value is held as long as the output is clamped.</p>
Bit 5: Derivative Term filter	<p>When bit 5 is 0, no derivative term filtering occurs.</p> <p>When bit 5 is 1, the rate of change of the Derivative Term is limited. This improves PID loop stability by reducing the effects of random variations (noise) and step changes in the Set Point and Process Variable inputs.</p>
Bit 0 - Bit 5:	<p>Remember that the bits are set in powers of 2.</p> <p>To set bit 0, add 1 to the Config Word parameter value.</p> <p>To set bit 1, add 2.</p> <p>To set bit 2, add 4.</p> <p>To set bit 3, add 8.</p> <p>To set bit 4, add 16.</p> <p>To set bit 5, add 32.</p> <p>For example, set Config Word to 0 for default PID configuration. Add 1 to change the Error Term from SP - PV to PV - SP, add 2 to change the Output Polarity from CV = PID Output to CV = - PID Output, or add 4 to change Derivative Action from Error rate of change to PV rate of change, etc.</p>