

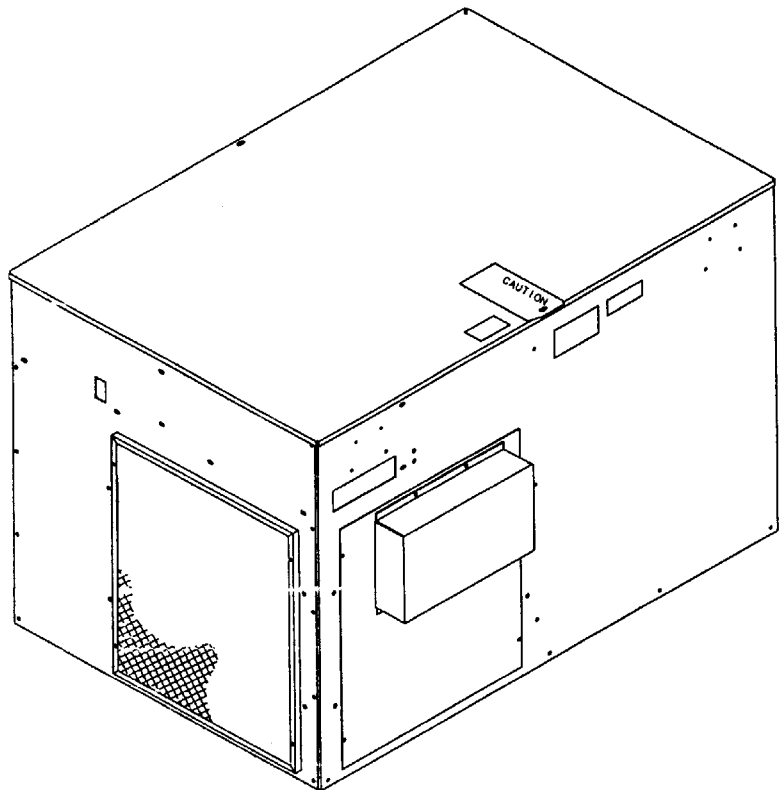

# AURORA® 10,000 PLUS COOLING UNIT

## Installation Manual



Part No. 300614000  
November 8, 1989  
Revised: April 12, 1993

THIS DOCUMENT CONTAINS IMPORTANT INFORMATION  
This Manual must be read and understood before installing or operating this equipment

# TABLE OF CONTENTS

	Page
<b>GENERAL INFORMATION</b> .....	<b>1</b>
GENERAL DESCRIPTION .....	1
COOLING UNIT DESCRIPTION .....	1
SYSTEM THEORY OF OPERATION .....	3
<b>INSTALLATION</b> .....	<b>5</b>
UNPACKING AND INSPECTION .....	5
IDENTIFICATION OF LOOSE-SHIPED PARTS .....	5
SELECTING LOCATION .....	5
COOLING UNIT .....	5
REMOTE CONDENSER COIL AND FAN ASS'Y .....	6
INSTALLING REMOTE CONDENSER COIL AND FAN ASS'Y .....	6
INSTALLING COOLING UNIT .....	6
PLACING COOLING UNIT IN LOCATION .....	6
CONNECTING REMOTE CONDENSER COIL AND FAN ASS'Y REFRIGERATION LINES TO COOLING UNIT .....	6
CONNECTING ELECTRICAL POWER CIRCUIT TO COOLING UNIT ....	7
CONNECTING ELECTRICAL POWER CIRCUIT TO REMOTE CONDENSER COIL AND FAN ASS'Y .....	8
CONNECTING PLAIN WATER INLET SUPPLY LINE TO COOLING UNIT	8
CONNECTING CO2 INLET SUPPLY LINE TO COOLING UNIT .....	9
CONNECTING SYRUP SOURCE LINES TO COOLING UNIT SYRUP INLET LINES .....	9
CONNECTING COOLING UNIT SYRUP OUTLET LINES TO INSULATED PYTHON SYRUP LINES .....	9
CONNECTING COOLING UNIT PLAIN WATER OUTLET LINES TO INSULATED PYTHON PLAIN WATER LINES .....	9
CONNECTING COOLING UNIT CARBONATED WATER OUTLET LINES TO INSULATED PYTHON CARBONATED WATER LINES .....	9
PLACING COOLING UNIT IN OPERATING POSITION .....	10
PREPARING COOLING UNIT FOR OPERATION .....	10
OPERATION .....	11
LEAK CHECK AND INSULATING COOLING UNIT OUTLET LINES .....	12
DISPENSING STATION ADJUSTMENTS .....	12
ADJUSTING WATER FLOW RATE .....	12
ADJUSTING WATER-TO-SYRUP "RATIO" OF DISPENSED PRODUCT	12
INSTALLING LINE IDENTIFICATION LABEL .....	12
<b>OPERATORS INSTRUCTIONS</b> .....	<b>13</b>
OPERATING CONTROLS .....	13
COOLING UNIT REFRIGERATION POWER SWITCH .....	13
COOLING UNIT CARBONATOR MOTOR SWITCH .....	13
COOLING UNIT CIRCULATING MOTOR SWITCH .....	13
REFRIGERATION SYSTEM TEMPERATURE SENSING DEVICE AND HIGH-PRESSURE CUTOFF SWITCH .....	13
DAILY PRE-OPERATION CHECK .....	14
ADJUSTMENTS .....	14

## TABLE OF CONTENTS (cont'd)

	Page
ADJUSTING CO2 REGULATORS .....	14
ADJUSTING DISPENSING VALVES WATER FLOW RATE .....	14
ADJUSTING WATER-TO-SYRUP "RATIO" OF DISPENSED PRODUCT ..	14
ADJUSTING SIZE OF DRINK DISPENSED .....	14
REPLENISHING CO2 SUPPLY .....	14
REPLENISHING SYRUP SUPPLY .....	14
CLEANING AND SANITIZING .....	14
DAILY CLEANING .....	14
SANITIZING SYRUP SYSTEMS .....	15
COOLING UNIT MAINTENANCE .....	15
COOLING UNIT AIR INTAKE AND EXHAUST FILTERS .....	15
CHECKING ICE WATER BATH .....	15
COOLING UNIT CARBONATOR MAINTENANCE .....	15
DOUBLE LIQUID CHECK VALVE ASSEMBLIES YEARLY MAINTENANCE (OR AFTER WATER SYSTEM DISRUPTIONS). .....	15
COOLING UNIT CARBONATED WATER CIRCULATING PUMP MOTOR LUBRICATION .....	15
REMOTE CONDENSER COIL AND FAN ASS'Y MAINTENANCE .....	16
CLEANING CO2 GAS CHECK VALVES .....	16
<b>SERVICE AND MAINTENANCE .....</b>	<b>17</b>
COOLING UNIT MAINTENANCE .....	17
PERIODIC CLEANING .....	17
CLEANING COOLING UNIT AIR INTAKE AND EXHAUST FILTERS. ....	17
PREPARING COOLING UNIT FOR SHIPPING, STORING, OR RELOCATING	17
PERIODIC INSPECTION .....	17
REMOTE CONDENSER COIL AND FAN ASSEMBLY MAINTENANCE .....	18
CHECKING ICE WATER BATH .....	18
CHANGING ICE WATER BATH .....	18
DOUBLE LIQUID CHECK VALVE ASSEMBLIES YEARLY MAINTENANCE (OR AFTER WATER SYSTEM DISRUPTIONS) .....	19
LUBRICATION .....	21
ADJUSTMENTS .....	21
PRIMARY CO2 REGULATOR .....	21
SECONDARY CO2 REGULATORS .....	21
WATER FLOW RATE .....	22
WATER-TO-SYRUP "RATIO" OF DISPENSED PRODUCT .....	22
CLEANING AND SANITIZING .....	22
DAILY CLEANING OF UNIT .....	22
SANITIZING POST-MIX SYRUP SYSTEMS .....	23
REPLENISHING CO2 SUPPLY .....	26
REPLENISHING SYRUP SUPPLY .....	26
SYRUP FLAVOR CHANGE .....	27
CLEANING CO2 SYSTEM GAS CHECK VALVES .....	27
SECONDARY CO2 REGULATORS AND CO2 MANIFOLD CO2 GAS CHECK VALVES .....	27

## TABLE OF CONTENTS (cont'd)

	Page
COOLING UNIT CO2 INLET LINE CO2 GAS CHECK VALVE .....	27
<b>TROUBLESHOOTING .....</b>	<b>30</b>
WATER-TO-SYRUP "RATIO" OF DISPENSED DRINK TOO LOW OR TOO HIGH. ....	30
ADJUSTMENT OF DISPENSING VALVE SYRUP FLOW REGULATOR DOES NOT INCREASE TO DESIRED WATER-TO-SYRUP "RATIO". ....	30
ADJUSTMENT OF DISPENSING VALVE SYRUP FLOW REGULATOR DOES NOT DECREASE TO DESIRED WATER-TO-SYRUP "RATIO". ....	31
DISPENSED PRODUCT CARBONATION TOO LOW. ....	31
DISPENSED PRODUCT COMES OUT OF DISPENSING VALVE CLEAR BUT FOAMS IN CUP. ....	31
DISPENSED PRODUCT PRODUCES FOAM AS IT LEAVES DISPENSING VALVE. ....	31
ONLY CARBONATED WATER DISPENSED. ....	31
ONLY SYRUP DISPENSED. ....	32
WARM PRODUCT BEING DISPENSED. ....	32
WATER PUMP MOTOR WILL NOT OPERATE. ....	32
WATER PUMP MOTOR WILL NOT SHUT OFF. ....	32
ERRATIC CYCLING OF CARBONATOR. ....	32
WATER PUMP MOTOR OPERATES BUT WATER PUMP DOES NOT PUMP WATER. ....	33
WATER PUMP CAPACITY TOO LOW. ....	33
COMPRESSOR DOES NOT OPERATE. ....	33
COMPRESSOR OPERATES CONTINUOUSLY BUT DOES NOT FORM SUFFICIENT ICE BANK .....	34
CONDENSER FAN MOTOR NOT OPERATING .....	35
AGITATOR MOTOR NOT OPERATING. ....	35
<b>WARRANTY .....</b>	<b>36</b>

### LIST OF FIGURES

FIGURE 1. AURORAR10,000 PLUS COOLING UNIT .....	1
FIGURE 2. FLOW DIAGRAM (TYPICAL INSTALLATION) .....	4
FIGURE 3. 240/24VAC POWER TRANSFORMER .....	7
FIGURE 4. COOLING UNIT SPACE REQUIRED .....	10
FIGURE 5. PARTS IDENTIFICATION .....	20
FIGURE 6. LIQUID CHECK VALVE ASSEMBLY .....	22
FIGURE 7. CO2 GAS CHECK VALVE .....	26
FIGURE 8. REFRIGERATION FLOW DIAGRAM (REQUIRES CONNECTION TO REMOTE CONDENSER COIL AND FAN ASS'Y) .....	28
FIGURE 9. WIRING DIAGRAM .....	29

### LIST OF TABLES

TABLE 1. DESIGN DATA .....	2
TABLE 2. LOOSE-SHIPED PARTS .....	5

# GENERAL INFORMATION

**IMPORTANT:** To the user of this manual - This manual is a guide for installing, operating, and maintaining this equipment. Refer to Table of Contents for page location of detailed information pertaining to questions that arise during installation, operation, service and maintenance, or troubleshooting this equipment.

## GENERAL DESCRIPTION

This section gives the description, theory of operation, and design data for the Aurora® 10,000 Plus Cooling Unit, hereafter referred too as a Cooling Unit.

## COOLING UNIT DESCRIPTION

The Cooling Unit is designed to provide cooled syrup, carbonated water, and plain water to the dispensing station through an insulated python (length as ordered). The Cooling Unit refrigeration system is cooled by a Remote Condenser Coil and Fan Assembly which is connected to the Cooling Unit.

The Cooling Unit consists of a refrigeration system with a two horsepower compressor and a Hydro Boost® (plain water pre-cooler) which pre-cools plain water on its way to the carbonated water tank. The Cooling Unit also consists of a plain water pump. The plain water pump pumps plain water through the Hydro Boost®, through the plain water cooling coils, and into the carbonated water tank. The carbonated water circulating pump circulates cold carbonated water from the Cooling Unit to the dispensing station and back to the Cooling Unit.

The cabinet panels are easily removed to facilitate installation and service and maintenance.

An optional Cooling Unit Stand (P/N 309309000) is available to elevate Cooling Unit up off floor. Also available is an Aurora Service System Analyzer (P/N 30919700) that may be used to analyze and troubleshoot the Cooling Unit refrigeration system.



**CAUTION:** Before shipping or relocating the Cooling Unit syrup cooling coils must be sanitized and all sanitizing solution must be purged from the coils. All water must also be purged from the plain and carbonated water systems. A freezing ambient environment will cause residual sanitizing solution or water remaining inside the Cooling Unit to freeze resulting in damage to internal components.

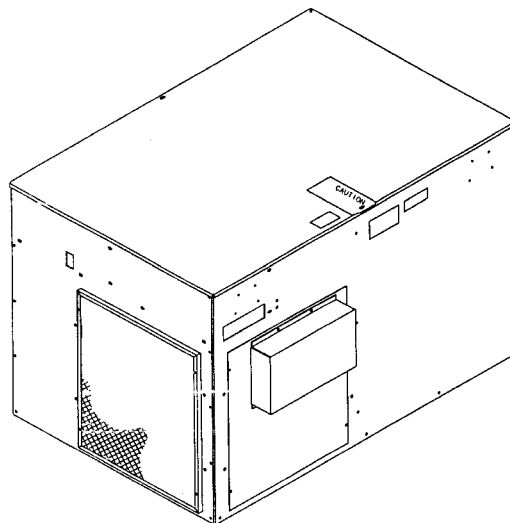

FIGURE 1. AURORA® 10,000 PLUS COOLING UNIT

**Table 1. Design Data**

**COOLING UNIT DATA**

Model No.	416654
Overall Dimensions:	
Height	25-inches
Width	36-1/2 inches
Depth	24-1/2 inches
<b>NOTE: Overall dimensions if Cooling Unit is placed on optional Cooling Unit Stand (P/N 309309069).</b>	
Height (approximate)	72-5/16 inches
Width	37-1/2 inches
Depth	25-3/8 inches
Weights:	
Shipping	385 pounds
Dry Weight	pounds
Ice Bank Weight	40 ± pounds
Capacities:	
Water Bath (no ice bank)	18 gallons
Compressor Horsepower	2 HP
Refrigeration System:	
Refrigerant Type and Charge	See Cooling Unit Nameplate
Ambient Operating Temp.	50° F to 100° F
Electrical Requirements:	
Operating Voltage	See Cooling Unit Nameplate
Current Draw	
<b>REMOTE CONDENSER COIL AND FAN ASS'Y DATA (P/N 309602000)</b>	
Overall Dimensions:	
Height	27 inches
Width	22-inches
Depth	38-inches
Weight:	
Shipping	85 pounds
Ambient Operating Temp.	-22° F to 158° F
Electrical Requirements:	
Operating Voltage	208/230VAC, Single Phase, 60Hz
Current Draw	2.5 Amps

## SYSTEM THEORY OF OPERATION

(see Figure 2)

A CO<sub>2</sub> cylinder delivers carbon dioxide gas (CO<sub>2</sub>) to primary CO<sub>2</sub> regulator assembly which deliver regulated CO<sub>2</sub> gas to adjustable secondary CO<sub>2</sub> regulators. Secondary CO<sub>2</sub> regulators delivers regulated CO<sub>2</sub> gas to the carbonated water tank inside the Cooling Unit and also to the soft drink tanks. Plain water enters the Cooling Unit and is pumped through and is pre-cooled by the refrigerated Hydro Boostâ coil. Cooled water continues through the plain water cooling coils and into the carbonated water tank. Cold plain water entering the carbonated water tank is carbonated by regulated CO<sub>2</sub> gas pressure also entering the tank. Carbonated water leaves the carbonated water tank and enters the inlet side of the carbonated water circulating pump. Carbonated water passes through the carbonated water circulating pump, through the carbonated water cooling coil, and exits the Cooling Unit through an insulated python to a turnaround inside the dispensing station. Carbonated water returns to the Cooling Unit by passing through the insulated python, through the Cooling Unit carbonated water cooling coils, through the carbonated water tank which makes up the carbonated water circulating system. As carbonated water is being dispensed from the dispensing station, carbonated water circulating system is continuously being replenished from the carbonated water tank.

Plain water enters through the Cooling Unit two plain water inlet lines, through the plain water cooling coils, and exists the Cooling Unit out through insulated python to the dispensing station. Regulated CO<sub>2</sub> gas pressure exerted upon the soft drinks contents forces syrup from tanks, through Cooling Unit syrup inlet lines, through syrup cooling coils, and exists the Cooling Unit out through an insulated python to the dispensing station.

The Cooling Unit refrigeration system is cooled by a Remote Condenser Coil and Fan Assembly (P/N 309602000) that is authorized by IMI Cornelius Inc. Use of any other Remote Condenser Coil and Fan Assembly must be authorized by IMI Cornelius Inc. Use of an unauthorized Remote Condenser Coil and Fan Assembly will automatically void the Cooling Unit factory warranty.

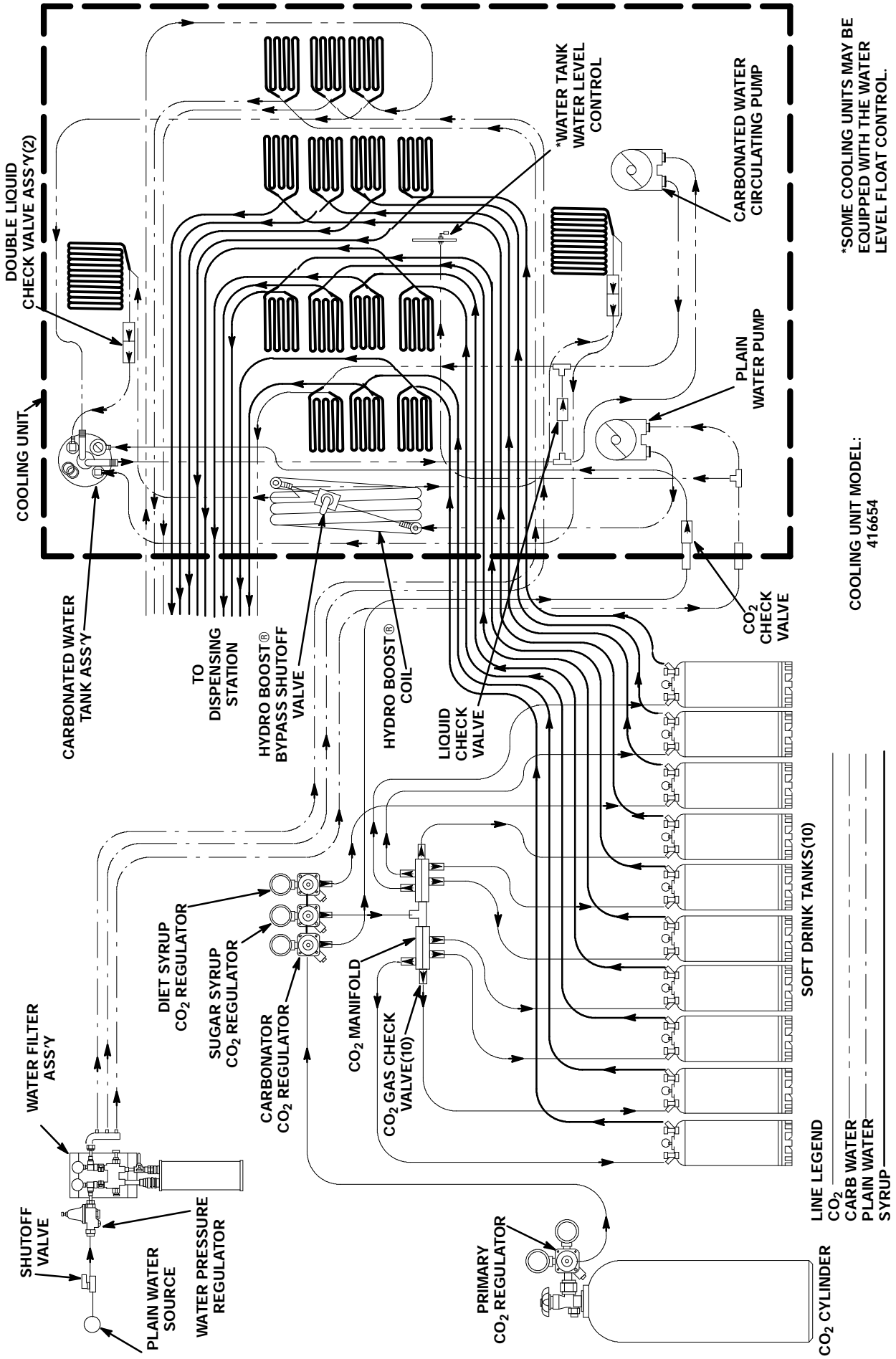

\*SOME COOLING UNITS MAY BE EQUIPPED WITH THE WATER LEVEL FLOAT CONTROL.

COOLING UNIT MODEL:  
416654

FIGURE 2. FLOW DIAGRAM (TYPICAL INSTALLATION)



# INSTALLATION

This section covers unpacking and inspection, selecting location, installing the Cooling Unit and the Remote Condenser Coil and Fan Assembly preparing for operation, and operation.

## UNPACKING AND INSPECTION

**NOTE: The Cooling Unit and the Remote Condenser Coil and Fan Assembly were thoroughly inspected before leaving the factory and the carrier has accepted and signed for them. Any damage or irregularities should be noted at time of delivery (or not later than 15 days from date of delivery) and immediately reported to the delivering carrier. Request a written inspection report from Claims Inspector to substantiate any necessary claim. File claim with the delivering carrier, not with IMI Cornelius Inc.**

1. After Cooling Unit has been unpacked, remove shipping tape and other packing material.
2. Unpack LOOSE-SHIPPED PARTS. Make sure all items are present and in good condition.

<b>Table 2. Loose-Shipped Parts</b>			
<b>Item No.</b>	<b>Part No.</b>	<b>Name</b>	<b>Qty.</b>
1	309852000	Tubing Clamp	24
2	770407	Barbed Connector, 1/4 by 3/8	12
3	770424	Barbed Connector, 1/2 by 1/2	2
4	311962000	Label, Line Identification	1
<b>NOTE: The following Remote Condenser Coil and Fan Assembly and Refrigeration Line Kits are recommended for use with Cooling Unit (P/N 416654000). Refrigeration Lines Kit (as ordered) is used to connect Condenser Coil and Fan Assembly to the Cooling Unit.</b>			
5	309602000	Remote Condenser Coil and Fan Ass'y	1
6	300598025	Refrigeration Line Kit, 25-ft. long, 90	1
	300598050	Refrigeration Line Kit, 50-ft. long, 90	1

## IDENTIFICATION OF LOOSE-SHIPPED PARTS

1. BARBED CONNECTORS (item 2) used to connect Cooling Unit outlet lines to insulated python lines. Connections are secured with TUBING CLAMPS (item 1).
2. BARBED CONNECTORS (item 3) are used to connect Cooling Unit outlet carbonated water lines to insulated python lines.
3. LABEL, LINE IDENTIFICATION (item 4) to be installed on Cooling Unit and syrup flavors to be recorded in proper spaces on label.
4. REFRIGERATION LINE KIT (items 6) is used to connect REMOTE CONDENSER COIL AND FAN ASS'Y (item 5) to Cooling Unit.

## SELECTING LOCATION

### COOLING UNIT

Select location for Cooling Unit installation that will (1) Allow the shortest possible insulated python route from the Cooling Unit to the Dispensing Station location; (2) Allow the shortest possible refrigeration lines (not to exceed 50-ft in length) route from Remote Condenser Coil and Fan Assembly to the Cooling Unit; (3) REFER TO THE COOLING UNIT NAMEPLATE FOR THE REQUIRED POWER CIRCUIT OPERATING VOLTAGE, HZ, AND THE MINIMUM CIRCUIT AMPACITY OF THE COOLING UNIT. The power circuit for the Cooling Unit must be wired through a 40-amp minimum rated disconnect switch (not provided) and the power circuit must be

fused as indicated on the Unit nameplate. The power circuit may also be wired through an equivalent HACR type circuit breaker rather than the disconnect switch. THE POWER CIRCUIT MUST BE MADE UP OF COPPER CONDUCTORS AND ALL WIRING MUST CONFORM TO NATIONAL AND LOCAL ELECTRICAL CODES; (4) Close to a plain water source supply line with proper requirements; (5) Sufficient space around Cooling Unit (see Figure4) for proper air circulation (18-inches on sides and back, front side open to room, and top open to ceiling); (6) Be close to permanent floor drain to route Cooling Unit water tank drain and overflow hoses to the floor drain.

## REMOTE CONDENSER COIL AND FAN ASS'Y



**CAUTION: Remote Condenser Coil and Fan Assemblies authorized by IMI Cornelius Inc. (P/N 309602000)**

1. An extreme warm climate installation may require extra caution in Remote Condenser Coil and Fan Assembly location. Avoid hot sunny locations and seek shaded area if possible. The use of a structure to shade the Unit from direct sun exposure and/or a platform extending Unit an additional 18-inches above the rooftop is highly recommended and will improve performance. Ample space must be provided on all sides and above Unit for proper air circulation through Unit and also access for service and maintenance. **DO NOT BLOCK AIR CIRCULATION THROUGH UNIT.**
2. Remote Condenser Coil and Fan Assembly must be installed in level position and must be anchored with adequate fastening devices.

## INSTALLING REMOTE CONDENSER COIL AND FAN ASS'Y

(see Figure 6)

1. Remote Condenser Coil and Fan Assembly must be installed meeting requirements of **SELECTING LOCATION**. Remote Condenser Coil and Fan Assembly must be installed in a level position and must be anchored with adequate fastening devices.
2. Route refrigeration lines of **REFRIGERATION LINE KIT** (item 6) from Remote Condenser Coil and Fan Assembly down to Cooling Unit location.
3. Connect ends of refrigeration lines to Condenser Coil and Fan Assembly refrigeration connectors.

## INSTALLING COOLING UNIT

**NOTE: Cooling Unit outlet lines, plain water, CO<sub>2</sub>, and syrup inlet lines, Remote Condenser Coil and Fan Assembly refrigeration lines and power circuit cable, and Cooling Unit power circuit cable each must be long enough when connected to Cooling Unit to allow pulling Unit out approximately 36-inches from operating position for service and maintenance. When Cooling Unit is in operating position, excess power circuit cable, Remote Condenser Coil and Fan Assembly refrigeration lines and power circuit cable and plain water source and CO<sub>2</sub> inlet lines may be coiled up behind Unit.**

## PLACING COOLING UNIT IN LOCATION

**NOTE: An optional Cooling Unit Stand (P/N 309309069) is available to elevate Cooling Unit up and off the floor.**

1. Place Cooling Unit in position approximately 36-inches out from operating position to allow access all around the Unit.
2. Remove two screws securing Cooling Unit top cover, then remove cover.

## CONNECTING REMOTE CONDENSER COIL AND FAN ASS'Y REFRIGERATION LINES TO COOLING UNIT

(see Figure 5)

Connect refrigeration lines, from Remote Condenser Coil and Fan Assembly, to refrigeration connectors on front of Cooling Unit.

## CONNECTING ELECTRICAL POWER CIRCUIT TO COOLING Unit

(see Figures 5 and 9)

**IMPORTANT:** Before 208/230VAC single-phase 60Hz electrical power circuit is connected to the cooling unit, service power voltage entering the building must be identified. Service power voltage entering the building will either be 208 or 230VAC and may be posted on the main service box. If not, the installer must contact the local electrical power company for information. If these two voltage identification attempts should fail, a voltage reading Must be performed. If service power voltage is below 218VAC, the red electrical wire connected to the 240VAC terminal on LINE (primary) side of the 240/24VAC power transformer inside the cooling unit switches electrical control box (see Figure 3 and 9) must be disconnected from the 240VAC terminal and be connected to the 208VAC terminal. If voltage is above 218VAC, power transformer red electrical wire will remain connected to the 240VAC terminal. If installer is not sure of the service power voltage entering the building, leave red electrical wire connected to the 240VAC terminal on the power transformer. If service power voltage is below 218VAC, proceed as follows:

1. Remove four screws securing electrical control box cover, then remove cover for access to the 240/24VAC power transformer.
2. Remove red electrical wire from the 240VAC terminal on LINE (primary) side of power transformer and connect it to the 208VAC terminal.

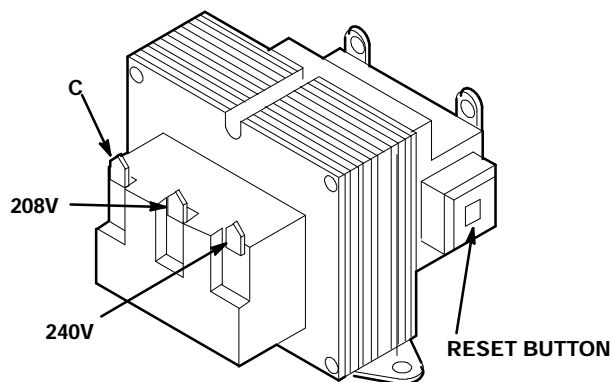

FIGURE 3. 240/24VAC POWER TRANSFORMER



**WARNING:** Make sure 40-amp minimum-rated disconnect switch (not provided) is in "OFF" position.

1. Remove cover from electrical handy box on back of Cooling Unit.



**WARNING:** The Cooling Unit must be electrically grounded to avoid possible fatal electrical shock or serious injury to the operator. A green ground wire is provided inside electrical box to connect power circuit ground wire which electrically grounds the Cooling Unit.

Connect 208/230VAC Single-Phase 60Hz power circuit from 40-amp minimum rated disconnect switch (not provided) fused at 40-amperes ("slow-blow") to electrical wires inside electrical handy box on back of Cooling Unit. COOLING UNIT MUST BE PROPERLY GROUNDED. POWER CIRCUIT MUST BE MADE UP OF COPPER CONDUCTORS, AND ALL WIRING MUST CONFORM TO NATIONAL AND LOCAL ELECTRICAL CODES.

DO NOT CONNECT ELECTRICAL POWER TO COOLING UNIT AT THIS TIME.

## CONNECTING ELECTRICAL POWER CIRCUIT TO REMOTE CONDENSER COIL AND FAN ASS'Y

(see Figure 5 and 9)



**CAUTION:** The Cooling Unit refrigeration system is cooled by a Remote Condenser Coil and Fan Assembly (P/N 309602000) that is authorized by IMI Cornelius Inc. Use of an unauthorized Remote Condenser Coil and Fan Assembly will automatically void the Cooling Unit factory warranty.

**NOTE:** Electrical power circuit may be connected to the Remote Condenser Coil and Fan Assembly (P/N 309602000) in two ways. The preferred way is to draw electrical power from the cooling unit contactor which allows the Remote Condenser Coil and Fan Assembly to operate only when the cooling unit refrigeration system is operating. The optional way is to connect a separate electrical power circuit (independent of the cooling unit) through an appropriately rated and fused disconnect switch or an equivalent HACR circuit breaker which allows the Remote Condenser Coil and Fan Assembly to operate at all times (independent of cooling unit operation).

1. Connect and route electrical power circuit cable from Remote Condenser Coil and Fan Assembly through fuse box (not provided), fused at 15-amps (maximum) down to Cooling Unit location. REMOTE CONDENSER COIL AND FAN ASSEMBLY MUST BE PROPERLY GROUNDED, POWER CIRCUIT MUST BE MADE UP OF COPPER CONDUCTORS, AND ALL WIRING MUST CONFORM TO NATIONAL AND LOCAL ELECTRICAL CODES.
2. Route Remote Condenser Coil and Fan Assembly Power cable electrical wires through electrical handy box on back of Cooling Unit to inside of electrical control box.
3. Connect Remote Condenser Coil and Fan Assembly power cable electrical wires to T<sub>1</sub> and T<sub>2</sub> terminals on contactor inside Cooling Unit electrical control box.
4. Install electrical control box cover and secure with four screws.
5. Install cover on electrical handy box on back of Cooling Unit.

## CONNECTING PLAIN WATER INLET SUPPLY LINE TO COOLING UNIT

(see Figure 2)

**NOTE:** IMI Cornelius Inc. recommends that a water shutoff valve be installed in plain water inlet supply line connected to Cooling Unit and that water supply be filtered. WATER PIPE CONNECTIONS AND FIXTURES DIRECTLY CONNECTED TO A POTABLE WATER SUPPLY SHALL BE SIZED, INSTALLED AND MAINTAINED ACCORDING TO FEDERAL, STATE, AND LOCAL LAWS.



**CAUTION:** Plain water inlet supply line to Cooling Unit must be 1/2-inch I.D. minimum. Check water flow rate of water inlet supply line. MINIMUM FLOW RATE MUST BE AT LEAST 300-GALLONS PER HOUR. If flow rate is less than 300-gallons per hour, "starving" of carbonator water pump will occur. Starving will allow water pump to overheat causing safety thermostat on pump outlet to disrupt electrical power to and stop water pump motor. Carbonated water circulating pump overheating could occur if water inlet supply line flow rate drops below 300-gallons per hour. INCOMING PLAIN WATER INLET SUPPLY LINE WATER PRESSURE MUST REMAIN A MINIMUM OF 10-PSI BELOW THE CARBONATOR CO<sub>2</sub> OPERATING PRESSURE. (Example: Operating pressure is 90-psi and maximum water pressure can be no more than 80-psi, etc.)

1. Before connecting plain water inlet supply line to Cooling Unit, open water line shutoff valve for a period of time to flush out any metal shavings and other contaminants that may have resulted from plumbing connections.

2. Connect flexible plain water inlet supply line (1/2-inch I.D. min.), meeting water inlet supply line requirements of preceding CAUTION note, to Cooling Unit 3/8-in. flare (5/8-18) bulkhead fitting on back of Unit labeled "WATER INLET". DO NOT OPEN WATER INLET SUPPLY LINE SHUTOFF VALVE AT THIS TIME.

## CONNECTING CO<sub>2</sub> INLET SUPPLY LINE TO COOLING UNIT

(see Figure 2)



**WARNING:** CO<sub>2</sub> displaces oxygen. Strict attention *must* be observed in the prevention of CO<sub>2</sub> (carbon dioxide) gas leaks in the entire CO<sub>2</sub> and soft drink system. If a CO<sub>2</sub> gas leak is suspected, particularly in a small area, *immediately* ventilate the contaminated area before attempting to repair the leak. Personnel exposed to high concentration of CO<sub>2</sub> gas will experience tremors which are followed rapidly by loss of consciousness and suffocation.

Connect flexible CO<sub>2</sub> inlet supply line to Cooling Unit 1/4-in. flare (7/16-20) bulkhead fitting of back of Unit labeled "CO<sub>2</sub> INLET". DO NOT TURN ON CO<sub>2</sub> SUPPLY TO COOLING UNIT AT THIS TIME.

## CONNECTING SYRUP SOURCE LINES TO COOLING UNIT SYRUP INLET LINES

(see Figure 2)

Connect syrup source lines, from No. 1 through No. 10 soft drink tanks location, to Cooling Unit syrup inlet lines labeled No. 1 through No. 10. DO NOT CONNECT SOFT DRINK TANKS INTO SYRUP SYSTEMS AT THIS TIME.

## CONNECTING COOLING UNIT SYRUP OUTLET LINES TO INSULATED PYTHON SYRUP LINES

(see Figure 2)

Connect Cooling Unit syrup outlet lines labeled No. 1 through No. 10, to insulated python lines labeled No. 1 through No. 10 using BARBED CONNECTORS (item 2). Secure connections with TUBING CLAMPS (item 1).

## CONNECTING COOLING UNIT PLAIN WATER OUTLET LINES TO INSULATED PYTHON PLAIN WATER LINES

(see Figure 2)

Connect Cooling Unit plain water outlet lines to insulated python plain water lines using BARBED CONNECTORS (item 2). Secure connections with TUBING CLAMPS (item 1).

## CONNECTING COOLING UNIT CARBONATED WATER OUTLET LINES TO INSULATED PYTHON CARBONATED WATER LINES

(see Figure 2)

**NOTE:** The Cooling Unit carbonated water outlet lines are used to make up the carbonated water circulating system between the Cooling Unit and the dispensing station as explained in SYSTEM THEORY OF OPERATION in GENERAL INFORMATION SECTION.

Connect Cooling Unit carbonated water outlet lines to insulated python carbonated water lines using BARBED CONNECTORS (item 3).

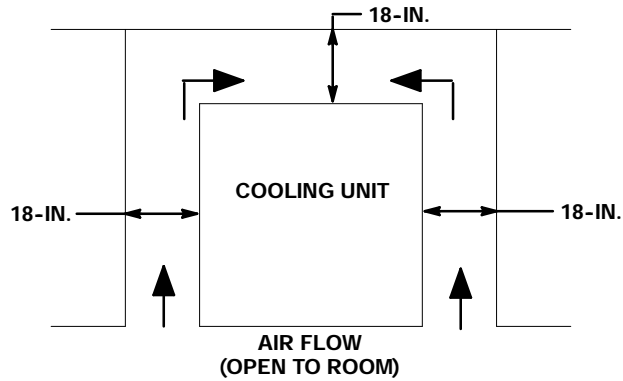

FIGURE 4. COOLING UNIT SPACE REQUIRED

## PLACING COOLING UNIT IN OPERATING POSITION

1. Very carefully, move Cooling Unit back into operating position leaving space around Unit (see Figure 4) as specified in *SELECTING LOCATION*. MAKE SURE THERE ARE NO KINKS IN COOLING UNIT INLET LINES, AND (IF APPLICABLE) REMOTE CONDENSER AND FAN ASSEMBLY REFRIGERATION LINES.

**NOTE: To comply with National Sanitation Foundation (NSF) requirements, Cooling Unit not installed on optional Cooling Unit Stand (P/N 309309-069) must have its base sealed to floor with Dow-Corning RTV 731 or equivalent.**

2. Tilt Cooling Unit up to expose bottom of Unit base.
3. Liberally apply silastic sealant such as Dow-Corning (RTV 731) or equivalent on Unit base bottom edges.

**NOTE: Do not move Cooling Unit after positioning or seal from Unit base to floor will be broken.**

4. Lower Cooling Unit into operating position to complete seal from Unit base to floor. Apply additional sealant around bottom of base. Seal must have a minimum radius of 1/2-inch to prevent cracks and crevices and to ensure a complete seal.
5. Route Cooling Unit water tank overflow hose to permanent floor drain.
6. Seal area around drain and overflow hoses where they exit from Unit using Dow Corning (RTV 731) or equivalent).

## PREPARING COOLING UNIT FOR OPERATION

1. Make sure plug in end of Cooling Unit water tank drain hose is secure.

**Note: Some Cooling Units are equipped with a water tank water level float control. Open shutoff valve in plain water inlet supply line. Due to slow water fill rate of the water level float control, water tank may be hand filled until water runs out of the water tank overflow hose. CLEAN LOW-MINERAL-CONTENT WATER MUST BE USED WHERE A LOCAL WATER PROBLEM EXIST.**

2. Fill water tank with clean water until water starts flowing from water tank overflow hose. USE LOW MINERAL CONTENT WATER WHERE A LOCAL WATER PROBLEM EXISTS.
3. Open shutoff valve in plain water inlet supply line.
4. Adjust primary CO<sub>2</sub> regulator (see Figure 2) on CO<sub>2</sub> cylinder to a minimum nominal setting of 120-psi or 24-psi higher than highest setting required by the secondary CO<sub>2</sub> regulators. Loosen CO<sub>2</sub> regulator adjusting screw locknut. Turn adjusting screw to the right (clockwise) until regulator gage registers nominal 120-psi, then tighten adjusting screw locknut.

5. Adjust carbonator secondary CO<sub>2</sub> regulator (see Figure 2) to a nominal 90-psi. Loosen CO<sub>2</sub> regulator adjusting screw locknut. Turn adjusting screw to the right (clockwise) until regulator gage registers nominal 90-psi, then tighten adjusting screw lock nut. CO<sub>2</sub> PRESSURE TO CARBONATORS MUST NOT EXCEED 120-PSIG.

## OPERATION



**WARNING: Disconnect electrical power to Cooling Unit and Remote Condenser Coil and Fan Assembly to prevent personal injury before attempting any Cooling Unit or Remote Condenser Coil and Fan Assembly internal maintenance. Only qualified personnel should service internal components or electrical wiring.**



**CAUTION: to prevent Hydro-Boost<sup>®</sup> coil freeze up during initial Cooling Unit start-up, the following start-up procedure must be performed as follows:**

1. Make sure Hydro Boost<sup>®</sup> bypass shutoff valve inside Cooling Unit (see Figure 2) is in "CLOSED" (handle not in line with tubing) position.
2. Make sure Cooling Unit REFRIGERATION POWER, CARBONATOR MOTOR, and CIRCULATING MOTOR Power switches are in "OFF" positions.
3. Connect electrical power to Cooling Unit at disconnect switch. Connect electrical power to Remote Condenser Coil and Fan Assembly at disconnect switch.
4. Place CARBONATOR MOTOR power switch in "ON" position.
5. Place REFRIGERATION power switch in "ON" position. Agitator motor and carbonator pump motor only will start and fill Hydro-Boost<sup>®</sup> coil with plain water. APPROXIMATELY 2-1/2 MINUTES AFTER CARBONATOR PUMP MOTOR HAS STARTED, REFRIGERATION COMPRESSOR, AND COMPRESSOR COOLING FAN, WILL START.

**NOTE: As ice bank forms in water tank, water expansion will take place and excess water will escape through water tank overflow hose to permanent floor drain.**

Cooling Unit will begin forming an ice bank and refrigerated Hydro-Boost<sup>®</sup> coil will also be chilling water. When full ice bank has been formed, Cooling Unit compressor and compressor cooling fan will stop but agitator motor will continue to operate circulating ice water bath in water tank.

6. Dispense from dispensing station until carbonated water appears at dispensing valve which indicates Cooling Unit plain and carbonated water systems have been filled.
7. Place CIRCULATING MOTOR power switch in "ON" position. Circulating pump will start and begin circulating carbonated water in carbonated water circulating system as explained in SYSTEM THEORY OF OPERATION in GENERAL INFORMATION SECTION.
8. Dispense carbonated water from dispensing valve to make sure all air has been purged from system.
9. If Cooling Unit plain water outlet line has been connected to a dispensing station dispensing valve, dispense from valve until all air has been purged from plain water system.
10. Adjust soft drink tanks secondary CO<sub>2</sub> regulators (see Figure 2) as follows: Sugar

### Syrup Soft Drink Tanks CO<sub>2</sub> Regulator.

Adjust sugar syrup soft drink tanks secondary CO<sub>2</sub> regulator at 40-psig for syrup lines up to 10-feet in length plus one pound for each additional length of 10-feet, plus one pound for each 2-feet of vertical lift. For example: if syrup line total length is 30-feet and total vertical lift is 6-feet, then 40-psig + 2-psig (1-pound for every 10-feet of length over 10-feet which is 20-feet) + 3-psig (1-pound for every 2-feet of vertical lift which is 6-feet); total equals 40 + 2 + 3 = 45-psig CO<sub>2</sub> regulator setting.

### Low-Calorie (diet) Syrup Soft Drink Tank CO<sub>2</sub> Regulator.

Adjust low-calorie (diet) soft drink tank secondary CO<sub>2</sub> regulator for low-calorie drink at 10-psig for syrup lines up to 30-feet in length. Syrup lines longer than 30-feet in length may require a slightly higher CO<sub>2</sub> regulator setting to 12-psig maximum. Excessive CO<sub>2</sub> pressure may cause low-calorie syrup carbonation resulting in foam.

**IMPORTANT: Syrup systems must be sanitized as instructed before syrup is connected into syrup systems.**

11. Connect soft drink tanks into syrup systems.
12. Dispense from dispensing station dispensing valves until product is dispensed.

## **LEAK CHECK AND INSULATING COOLING UNIT OUTLET LINES**

1. Check all CO<sub>2</sub>, plain and carbonated water, and syrup connections for leaks and repair if evident.
2. Make sure Cooling Unit outlet lines connections to insulated python lines are well insulated.
3. Install Cooling Unit top cover and secure with two screws.

## **DISPENSING STATION ADJUSTMENTS**

### **ADJUSTING WATER FLOW RATE**

Refer to Installation Instructions provided with Dispensing Station for dispensing valve water flow rate adjustment instructions.

### **ADJUSTING WATER-TO-SYRUP "RATIO" OF DISPENSED PRODUCT**

Adjust Dispensing Station dispensing valves for Water-to-Syrup "Ratio" of dispensed product as instructed in dispensing station Installation Instructions.

## **INSTALLING LINE IDENTIFICATION LABEL**

Install LABEL, LINE IDENTIFICATION (item 4) on Cooling Unit and record syrup flavors in proper spaces.



# OPERATORS INSTRUCTIONS

This section covers operating controls, daily pre-operation check, adjustments, replenishing CO<sub>2</sub> and syrup supplies, cleaning and sanitizing, Cooling Unit maintenance, Remote Condenser Coil and Fan Assembly maintenance, lubrication, and servicing CO<sub>2</sub> gas check valves.



**WARNING: Disconnect electrical power to Cooling Unit and Remote Condenser Coil and Fan Assembly to prevent personal injury before attempting any internal maintenance. Only qualified personnel should service internal components or electrical wiring.**

## OPERATING CONTROLS

### COOLING UNIT REFRIGERATION POWER SWITCH

(see Figure 5)

REFRIGERATION POWER switch, located on front of Cooling Unit, placed in "OFF" position will interrupt electrical power to refrigeration compressor, agitator motor, compressor cooling fan, carbonated water circulating pump, and the carbonator pump motor. REFRIGERATION POWER switch placed in "ON" position will start the carbonator pump motor (if carbonated water is being called for), the carbonated water circulating pump motor, and the agitator motor. Under certain conditions approximately 2-1/2 minutes after the REFRIGERATION POWER SWITCH has been placed in "ON" position refrigeration compressor and compressor cooling fan will start.

### COOLING UNIT CARBONATOR MOTOR SWITCH

(see Figure 5)

CARBONATOR MOTOR power switch, located on front of Cooling Unit, placed in "OFF" position will interrupt electrical power to carbonator pump motor. Switch must be placed in "ON" position before carbonator pump motor will operate.

### COOLING UNIT CIRCULATING MOTOR SWITCH

(see Figure 5)

CIRCULATING MOTOR power switch, located on front of Cooling Unit, placed in "OFF" position will interrupt electrical power to carbonated water circulating pump. Switch must be placed in "ON" position before circulating pump will operate.

### REFRIGERATION SYSTEM TEMPERATURE SENSING DEVICE AND HIGH-PRESSURE CUTOUT SWITCH

(see Figure 5)

This Cooling Unit is equipped with a refrigeration system temperature sensing device and a high-pressure sensing cutout switch that will shut refrigeration system down should the system overheat due to a clogged condenser coil in the Remote Condenser Coil and Fan Assembly. If refrigeration system does not automatically restart itself after system has cooled down, high-pressure sensing cutout switch (see Figure 5) will have to be pressed to reset switch. **MAKE SURE REFRIGERATION SYSTEM PROBLEM IS CORRECTED. OPERATING REFRIGERATION SYSTEM IN THIS MANNER FOR PROLONGED PERIOD OF TIME COULD RESULT IN COMPRESSOR FAILURE.**

## DAILY PRE-OPERATION CHECK

4. Make sure CO<sub>2</sub> cylinder regulator assembly 1800-psi gage indicator is not in shaded ("change CO<sub>2</sub> cylinder") portion of dial. If so, CO<sub>2</sub> cylinder is almost empty and must be replaced.
5. Sufficient syrup supply in all soft drink tanks. If not, replenish syrup supply as instructed.

## ADJUSTMENTS

### ADJUSTING CO<sub>2</sub> REGULATORS

CO<sub>2</sub> regulators should be periodically checked for proper pressure settings and if necessary, adjusted as instructed.

### ADJUSTING DISPENSING VALVES WATER FLOW RATE

If adjustment of dispensing valves water flow rate should be necessary, adjust as instructed in Dispensing Station Installation Instructions.

### ADJUSTING WATER-TO-SYRUP "RATIO" OF DISPENSED PRODUCT

Water-To-Syrup "Ratio" of dispensed product should be checked and if necessary, adjusted as instructed in Dispensing Station Installation Instructions.

### ADJUSTING SIZE OF DRINK DISPENSED

Adjust drink size of dispensed product as instructed in Dispensing Station Installation Instructions.

## REPLENISHING CO<sub>2</sub> SUPPLY



**WARNING:** CO<sub>2</sub> displaces oxygen. Strict attention *must* be observed in the prevention of CO<sub>2</sub> (carbon dioxide) gas leaks in the entire CO<sub>2</sub> and soft drink system. If a CO<sub>2</sub> gas leak is suspected, particularly in a small area, *immediately* ventilate the contaminated area before attempting to repair the leak. Personnel exposed to high concentration of CO<sub>2</sub> gas will experience tremors which are followed rapidly by loss of consciousness and suffocation.

**NOTE:** When indicator on CO<sub>2</sub> cylinder regulator assembly 1800-psi gage is in shaded ("change CO<sub>2</sub> cylinder") portion of the dial, CO<sub>2</sub> cylinder is almost empty and should be changed. CO<sub>2</sub> supply should be checked daily and if necessary, replenished as instructed.

### REPLENISHING SYRUP SUPPLY

Syrup supply should be checked daily and if necessary, replenished as instructed.

## CLEANING AND SANITIZING

### DAILY CLEANING

Perform daily cleaning of dispensing station as instructed in dispensing station installation instructions. Outside of Cooling Unit must be cleaned periodically.

## SANITIZING SYRUP SYSTEMS

Syrup systems should be sanitized every 90 days as instructed following Sanitizer Manufacturer's recommendations.

## COOLING UNIT MAINTENANCE

### COOLING UNIT AIR INTAKE AND EXHAUST FILTERS



**CAUTION:** Air filters on the Cooling Unit must be removed and cleaned every 30 days as instructed. Excessive accumulation of dust, lint, and grease on the air filters will restrict airflow through the Unit which will cause the refrigeration system to overheat.

The Cooling Unit cabinet is equipped with air intake and exhaust filters which allow air to circulate through the cabinet to cool the compressor. Air filters must be cleaned every 30 days as instructed. Area around Cooling Unit must be kept free of obstructions at all times for proper air circulation through the Unit.

### CHECKING ICE WATER BATH

**Note:** Some Cooling Units are equipped with a water tank water level float control. A gurgle heard from the Cooling Unit indicates water level in water tank is low. This indicates the water level float control is not operating properly and must be replaced.

A gurgle heard from the Cooling Unit indicates water level in water tank is low and more water should be added to the tank for maximum product cooling. Periodically check, and if necessary, add water to the water tank as instructed.

### COOLING UNIT CARBONATOR MAINTENANCE

#### Lubrication.

Carbonator water pump motor bearings must be oiled periodically as instructed.

### DOUBLE LIQUID CHECK VALVE ASSEMBLIES YEARLY MAINTENANCE (OR AFTER WATER SYSTEM DISRUPTIONS).

(see Figure 2)

The two double liquid check valve assemblies are located in plain water lines connected between the plain water cooling coils and the carbonated water tank. The double liquid check valve assemblies must be inspected and cleaned at least once a year under normal work, earthquake, etc.) Inspect and clean double liquid check valve assemblies as instructed.

### COOLING UNIT CARBONATED WATER CIRCULATING PUMP MOTOR LUBRICATION

Carbonated water circulating pump motor bearings must be oiled periodically as instructed.

## REMOTE CONDENSER COIL AND FAN ASS'Y MAINTENANCE

(see Figure 5)



**CAUTION:** Remote Condenser Coil and Fan Assembly connected to the Cooling Unit is equipped with a condenser coil that must be cleaned every 30-days. Allowing condenser coil to become clogged will cause refrigeration system to overheat which will automatically shut refrigeration system down. After condenser coil has been cleaned, high-pressure cutout sensing switch (see Figure 5) will have to be pressed to restart refrigeration system. **OPERATING COOLING UNIT IN THIS MANNER FOR PROLONGED PERIOD OF TIME COULD RESULT IN COMPRESSOR FAILURE.**

Area on top of and around Remote Condenser Coil and Fan Assembly must be kept free of obstruction at all times. Condenser coil must be cleaned as instructed to maintain proper cooling of coil.

## CLEANING CO<sub>2</sub> GAS CHECK VALVES

(see Figure 2)

The CO<sub>2</sub> gas check valves must be inspected and serviced at least once a year under normal conditions and after any CO<sub>2</sub> system servicing or disruption as instructed.

# SERVICE AND MAINTENANCE

The Remote Rooftop Condenser Coil and Fan Assembly Condenser Coil must be cleaned every 30 days. Circulating air, required to cool the coil, is drawn in at bottom and is exhausted out through top of Unit. Clean the condenser coil as follows:

1. Disconnect electrical power to Cooling Unit at disconnect switch, then disconnect electrical power from Remote Condenser Coil and Fan Assembly at disconnect switch.
2. Clean bottom side of condenser coil using vacuum cleaner, whisk broom, or soft-bristle brush to remove any debris from coil.
3. Check and make sure fan blade moves freely and is not touching any surfaces, are not bent, or out of balance. check and make sure wire guard is properly installed and securely fastened.
4. Check and make sure roof area immediately surrounding Unit is free and clear of any debris that may have collected such as leaves, paper, trash, etc.
5. Restore electrical power to Cooling Unit at disconnect switch, then connect electrical power to Remote Condenser Coil and Fan Assembly at disconnect switch.

## COOLING UNIT MAINTENANCE

### PERIODIC CLEANING

Periodically wash all external surfaces of Cooling Unit, rinse with clean water, then wipe dry with a clean soft cloth. DO NOT USE ABRASIVE TYPE CLEANERS.

### CLEANING COOLING UNIT AIR INTAKE AND EXHAUST FILTERS.

(see Figure 5).

This section describes Service and Maintenance procedures to be performed on Cooling Unit and Remote Condenser Coil and Fan Assembly.



**WARNING:** Disconnect electrical power to Cooling Unit and Remote Condenser Coil and Fan Assembly to prevent personal injury before attempting any Cooling Unit or Remote Condenser Coil and Fan Assembly internal maintenance. Only qualified personnel should service internal components or electrical wiring.

## PREPARING COOLING UNIT FOR SHIPPING, STORING, OR RELOCATING



**CAUTION:** Before shipping, storing, or relocating this Unit, the syrup systems *must* be sanitized and all sanitizing solution *must* be purged from the syrup systems. All water *must* also be purged from the plain and carbonated water systems. A freezing ambient environment will cause residual water in the Unit to freeze resulting in damage to internal components.

## PERIODIC INSPECTION

Check entire system for leaks or damaged components. Repair as necessary.

## REMOTE CONDENSER COIL AND FAN ASSEMBLY MAINTENANCE



**CAUTION:** Remote Condenser Coil and Fan Assembly connected to this Cooling Unit is equipped with a condenser coil that must be cleaned every 30-days. Allowing condenser coil to become clogged will cause refrigeration system to overheat which will automatically shut refrigeration system down. After condenser coil has been cleaned, high-pressure sensing cutout switch (see Figure 5) must be pressed to restart refrigeration system. **OPERATING COOLING UNIT IN THIS MANNER FOR PROLONGED PERIOD OF TIME COULD RESULT IN COMPRESSOR FAILURE.**



**CAUTION:** Air filters on the Cooling Unit must be removed and cleaned every 30 days as instructed. Excessive accumulation of dust, lint, and grease on the air filters will restrict airflow through the Unit which will cause the refrigeration system to overheat.

The Cooling Unit cabinet is equipped with air intake and exhaust filters which allow air to circulate through the cabinet to cool the compressor. The air filter must be cleaned every 30 days. Excessive accumulation of dust, lint, and grease on filters will restrict air flow through the Unit. Air filter may be removed and washed out with detergent solution or may be vacuumed. Area around Cooling Unit must be kept free of obstructions at all times for proper air circulation throughout the Unit.

### CHECKING ICE WATER BATH

(see Figure 5)

**Note:** Some Cooling Units are equipped with a water tank water level float control. A gurgle heard from the Cooling Unit indicates water level in water tank is low. This indicates the water level float control is not operating properly and must be replaced.

A gurgle heard from Cooling Unit indicates water level in water tank is low and more water should be added to the tank for maximum product cooling. Ice water bath and ice bank should be checked for cleanliness and water tank coils should be checked for excessive mineral deposit build-up as follows:

1. Disconnect electrical power from Cooling Unit at disconnect switch.
2. Remove two screws securing Cooling Unit top cover, then remove cover.
3. Using flashlight, inspect ice water bath and ice bank for cleanliness, ice water bath should be clear and ice bank free of foreign particles.
4. If cleaning of water tank is necessary, refer to CHANGING ICE WATER BATH in this section.
5. Fill water tank with clean water until water starts flowing from water tank overflow hose. USE LOW MINERAL CONTENT WATER WHERE A LOCAL WATER PROBLEM EXISTS.
6. Install Cooling Unit top cover and secure with two screws.
7. Restore electrical power to Cooling Unit at disconnect switch.

### CHANGING ICE WATER BATH

(see Figure 5)

1. Disconnect electrical power from Cooling Unit at disconnect switch.
2. Remove two screws securing Cooling Unit top cover, then remove cover.

**Note: If your Cooling Unit is equipped with a water tank water level float control, close shutoff valve in plain water inlet supply line.**

3. Make sure end of water tank drain hose is routed to floor drain, then remove plug from end of hose and allow water to drain from tank.



**CAUTION: Never use an ice pick or other instruments to remove ice from evaporator coils. Such practice can result in punctured refrigeration circuit.**

4. Allow ice bank to melt. Hot water may be used to speed melting.
5. Thoroughly rinse inside of water tank with clean water.
6. Install plug in end of water tank drain hose.

**Note: If your Cooling Unit is equipped with a water tank water level float control, open shutoff valve in plain water inlet supply line.**

7. Fill water tank with clean water until water starts flowing from water tank overflow hose. USE LOW MINERAL CONTENT WATER WHERE A LOCAL WATER PROBLEM EXISTS.
8. Install Cooling Unit top cover and secure with two screws.
9. Connect electrical power to Cooling Unit at disconnect switch.

## **DOUBLE LIQUID CHECK VALVE ASSEMBLIES YEARLY MAINTENANCE (OR AFTER WATER SYSTEM DISRUPTIONS)**

(see Figures 2 and 6)



**WARNING: The two double liquid check valve assemblies must be inspected and serviced at least once a year under normal circumstances, and after any disruptions (plumbing work, earthquake, etc.) to the water supply system that might cause turbulent (erratic) flow of water through the system. Fouled liquid check valves could cause CO<sub>2</sub> gas to back flow from the carbonated water tank into the water system and create a health hazard in the system.**

The two double liquid check valve assemblies are located in plain water lines connected between the plain water cooling coils and the carbonated water tank. Inspect and clean the double liquid check valve assemblies as follows:

1. Disconnect electrical power from Cooling Unit at disconnect switch.
2. Close shutoff valve in plain water inlet supply line.
3. Note pressure setting on carbonator CO<sub>2</sub> regulator, then turn regulator adjusting screw to the left (counterclockwise) until regulator gage reads 0-psi.
4. Pull up on carbonator tank relief valve to release CO<sub>2</sub> pressure from tank.
5. Remove two screws securing Cooling Unit top cover, then remove cover.
6. Remove double liquid check valve assembly from plain water line connected between plain water cooling coil and carbonated water tank.
7. Remove one check valve from the other, then disassemble each check valve as shown in Figure 6.

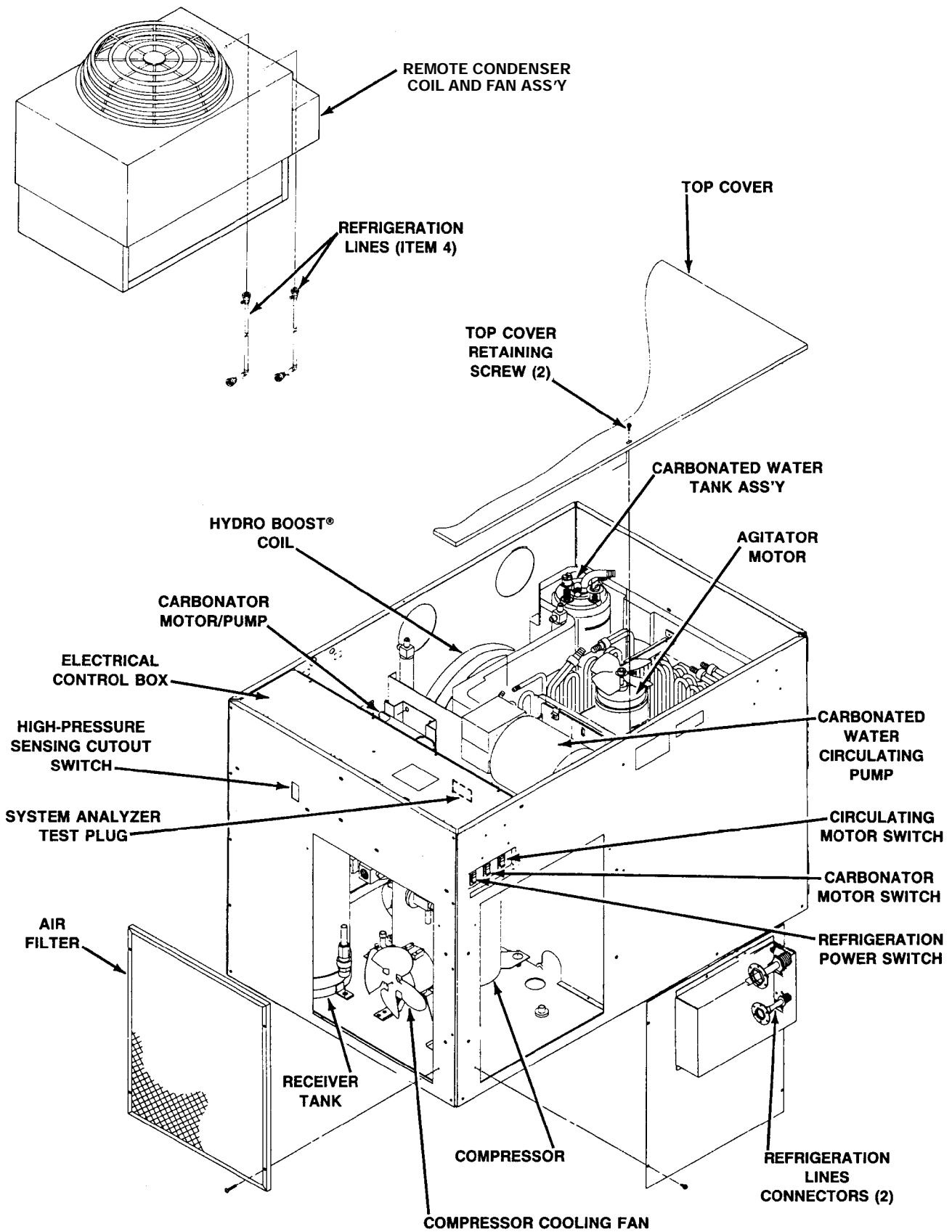

FIGURE 5. PARTS IDENTIFICATION



8. Wipe each part with clean lint-free cloth. Inspect each part, especially the ball, for burrs, nicks, corrosion, deterioration, and other damage. Discard ball seat and any damaged or suspicious parts and replace with new parts during reassemble.
9. Reassemble check valves as shown in Figure 6. ALWAYS install new ball seat (QUAD RING) (P/N 312418-000).

**NOTE: Make sure when assembling check valves together, check valve female end with white tapered gasket inside, is on inlet side of double liquid check valve assembly.**

10. Assemble check valves together. DO NOT OVERTIGHTEN.
11. Install double liquid check valve assembly in plain water line connected between plain water cooling coil and carbonated water tank.
12. Repeat preceding steps 6 through 11 to service other double liquid check valve in other plain water line connected between plain water cooling coil and carbonated water tank.
13. Turn carbonator CO<sub>2</sub> regulator adjusting screw to the right (clockwise) until its gage indicates pressure setting observed in step 3 preceding.
14. Open shutoff valve in plain water inlet supply line.
15. Restore electrical power to Cooling Unit at disconnect switch.
16. Dispense carbonated water at dispensing station and allow carbonator to cycle on and off. Check for water leaks and repair if evident.
17. Disconnect electrical power from Cooling Unit at disconnect switch.
18. Install Unit top cover and secure with two screws.
19. Restore electrical power to Cooling Unit at disconnect switch.

## LUBRICATION

The carbonator water pump and the carbonated water circulating pump motor bearings must be oiled periodically, refer to oiling instructions on the motors. DO NOT OVER OIL.

## ADJUSTMENTS

**NOTE: To readjust CO<sub>2</sub> regulator to a lower setting loosen adjusting screw lock nut, then turn screw to the left (counterclockwise) until pressure gage reads 5-psi lower than new setting will be. Turn adjusting screw to the right (clockwise) until gage registers new setting, then tighten lock nut.**

### PRIMARY CO<sub>2</sub> REGULATOR

(see Figure 2).

Adjust primary CO<sub>2</sub> regulator on CO<sub>2</sub> cylinder to a minimum nominal setting of 120-psi or 24-psi higher than highest setting required by the secondary CO<sub>2</sub> regulators. Loosen CO<sub>2</sub> regulator adjusting screw locknut. Turn adjusting screw to the right (clockwise) until regulator gage registers nominal 120-psi, then tighten adjusting screw locknut.

### SECONDARY CO<sub>2</sub> REGULATORS

(see Figure 2).

#### Carbonator Secondary CO<sub>2</sub> Regulator.

Adjust carbonator secondary CO<sub>2</sub> regulator to a nominal 90-psi. Loosen CO<sub>2</sub> regulator adjusting screw locknut. Turn adjusting screw to the right (clockwise) until regulator gage registers nominal 90-psi, then tighten adjusting screw locknut. CO<sub>2</sub> PRESSURE TO CARBONATORS MUST NOT EXCEED 125-PSIG.

## Sugar Syrup Soft Drink Tanks CO<sub>2</sub> Regulators.

Adjust sugar syrup soft drink tanks secondary CO<sub>2</sub> regulator at 40-psig for syrup lines up to 10-feet in length plus one pound for each additional length of 10-feet, plus one pound for each 2-feet of vertical lift. For example: if syrup line total length is 30-feet and total vertical lift is 6-feet, then 40-psig + 2-psig (1-pound for every 10-feet of length over 10-feet which is 20-feet) + 3-psig (1-pound for every 2-feet of vertical lift which is 6-feet); total equals 40 + 2 + 3 = 45-psig CO<sub>2</sub> regulator settings.

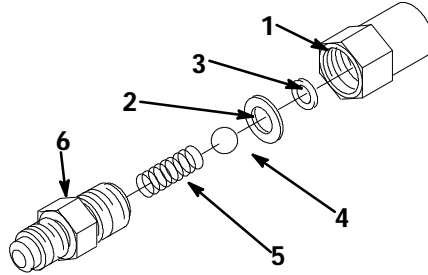

ITEM NO	PART NO	NAME
1	317963000	Housing
2	312415000	Flat Washer, Stainless Steel
3	*312418000	Ball Seat (quad ring)
4	312419000	Ball
5	312196000	Spring
6	317965000	Retainer

**FIGURE 6. LIQUID CHECK VALVE ASSEMBLY**

## Low-Calorie (diet) Syrup Soft Drink Tank CO<sub>2</sub> Regulator.

Adjust low-calorie (diet) soft drink tank secondary CO<sub>2</sub> regulator for low-calorie drink at 10-psig for syrup lines up to 30-feet in length. Syrup lines longer than 30-feet in length may require a slightly higher CO<sub>2</sub> regulator setting to 12-psig maximum. Excessive CO<sub>2</sub> pressure may cause low-calorie syrup carbonation resulting in foam.

## **WATER FLOW RATE**

Refer to Installation Instructions provided with Dispensing Station for dispensing valve water flow rate adjustment instructions.

## **WATER-TO-SYRUP "RATIO" OF DISPENSED PRODUCT**

Adjust dispensing station dispensing valves for Water-to-Syrup "Ratio" of dispensed product as instructed in dispensing station Installation Instructions.

## **CLEANING AND SANITIZING**

### **DAILY CLEANING OF UNIT**

1. Remove cup rest from the drip tray.

2. Wash drip tray in place on the Unit, then rinse drip tray with hot water allowing water to drain out through the drain hose.
3. Wash cup rest, then rinse the cup rest with clean water. Install cup rest in the drip tray.
4. Clean all external surfaces of the Unit with a sponge. Rinse out the sponge with clean water, then wring excess water out of the sponge and wipe off all external surfaces on the Unit. Wipe Unit dry with a clean soft cloth. **DO NOT USE ABRASIVE CLEANERS.**
5. Remove nozzle and syrup diffusers from the dispensing valves. Place nozzles and syrup diffusers in sanitizing solution.
6. Wash the nozzles and syrup diffusers in sanitizing solution, then rinse them with potable water.
7. Re-install nozzles and syrup diffusers back on the dispensing valves.

## **SANITIZING POST-MIX SYRUP SYSTEMS**

**IMPORTANT: Only qualified Service Personnel should perform sanitizing procedure on the post-mix syrup systems.**

The post-mix syrup systems should be sanitized every 90-days using a non-scented household liquid bleach containing a 5.25 % sodium hypochlorite concentration. Proceed as follows to sanitize the post-mix syrup systems.

1. Disconnect syrup supplies from syrup systems.
2. Rinse quick disconnects (syrup tanks systems) or bag-in-box connectors (syrup bag-in-box systems) in warm potable water.

### **STEP 1. WASH SYRUP SYSTEMS**

3. Using a clean syrup tank (syrup tank system) or a five-gallon container (bag-in-box system), prepare a full tank or container of liquid dishwasher detergent by using 70° F (21° C) to 100° F (38° C) potable water and 0.5 oz. (15 ml) of liquid dishwasher detergent to one gallon of potable water. Stir detergent solution to thoroughly mix the solution.
4. Syrup Tank Systems.
  - A. Observe and note CO<sub>2</sub> pressure setting on the syrup tanks CO<sub>2</sub> regulator, then re-adjust CO<sub>2</sub> regulator to 60 to 80-psi. Pressurize syrup tank containing detergent solution to 60 to 80-psi.
  - B. Connect detergent solution tank, pressurized at 60 to 80-psi, into one of the syrup systems.

#### Bag-in Box Syrup Systems.

- C. Install bag valves, cut from empty bag-in-box syrup containers, on ends of syrup containers syrup outlet tubes connectors.
- D. Place all syrup outlet tubes, with bag valves on their ends, in container containing detergent solution.
5. Flush the syrup system and dispensing valve as follows:
  - A. Place waste container under applicable dispensing valve.
  - B. Activate the dispensing valve for one minute to purge all syrup and flush out the syrup system.
  - C. Continue to activate the dispensing valve in cycles ("ON" for 15-seconds, "OFF", then "ON" for 15-seconds). Repeat "ON" and "OFF" cycles for 15-cycles.
6. Connect detergent solution to the remaining syrup systems and flush syrup out of the syrup systems as instructed in step NO TAG preceding.

7. Remove detergent solution source from the syrup system.

## STEP 2. FLUSH SYRUP SYSTEMS

### 8. Syrup Tank Systems.

Connect syrup tank containing potable water, pressurized at 60 to 80-psi, into one of the syrup systems.

#### Bag-in-Box Syrup System.

Fill five-gallon container with potable water, then place all bag-in-box syrup containers syrup outlet tubes in container containing potable water.

9. Flush detergent solution out of the syrup system and dispensing valve as follows:
  - A. Place waste container under applicable dispensing valve.
  - B. Activate the dispensing valve for one minute to purge all detergent solution and flush out the syrup system.
  - C. Continue to activate the dispensing valve in cycles ("ON" for 15-seconds, "OFF", then "ON" for 15-seconds). Repeat "ON" and "OFF" cycles for 15-cycles.
10. Connect potable water source to the remaining syrup systems and flush detergent solution out of the syrup systems as instructed in step NO TAG preceding.
11. Remove potable water source from the syrup system.

## STEP 3. SANITIZE SYRUP SYSTEMS

12. Using a clean syrup tank (syrup tanks system) or a five-gallon container (bag-in-box system), prepare sanitizing solution using 70° F (21° C) to 100° F (38° C) potable water and 0.5 oz. (15 ml) of non-scented household liquid bleach that contains a 5.25 % sodium hypochlorite concentration to one gallon of potable water. This mixture *must not* exceed 200 PPM of chlorine. Stir sanitizing solution to thoroughly mix.

### 13. Syrup Tank Systems.

Connect sanitizing solution tank, pressurized at 60 to 80-psi, into one of the syrup systems.

#### Bag-in-Box Syrup System.

Place all bag-in-box syrup containers syrup outlet tubes in container containing sanitizing solution.

14. Sanitize the syrup system and dispensing valve as follows:
  - A. Place waste container under applicable dispensing valve.
  - B. Activate the dispensing valve for one minute to purge all water from and install sanitizing solution in the syrup system and dispensing valve.
  - C. Continue to activate the dispensing valve in cycles ("ON" for 15-seconds, "OFF", then "ON" for 15-seconds). Repeat "ON" and "OFF" cycles for 15-cycles.
15. Repeat steps NO TAG and NO TAG to flush water out of and install sanitizing solution in the remaining syrup systems and dispensing valves.
16. Remove sanitizing solution source from the syrup system.
17. Allow sanitizing solution to remain in the syrup systems for not less than 10 or no more than 15-minutes (max.) contact time.

## STEP 4. WATER FLUSH SYRUP SYSTEMS



**WARNING: Flush sanitizing solution from the syrup systems as instructed. Residual sanitizing solution left in the syrup systems could create a health hazard.**

18. Fill syrup tank (syrup tank system) or a five-gallon container (bag-in-box system) with potable water.
19. Syrup Tank Systems.  
Connect syrup tank containing potable water, pressurized at 60 to 80-psi, into one of the syrup systems.  
Bag-in-Box Syrup System.  
Place all bag-in-box syrup containers syrup outlet tubes in container containing potable water.
20. Flush sanitizing solution from the syrup system and the dispensing valve as follows:
  - A. Place waste container under applicable dispensing valve.
  - B. Activate the dispensing valve for one minute to purge all sanitizing solution out of the syrup system and the dispensing valve.
  - C. Continue to activate the dispensing valve in cycles ("ON" for 15-seconds, "OFF", then "ON" for 15-seconds). Repeat "ON" and "OFF" cycles for 15-cycles.
21. Repeat steps NO TAG and NO TAG preceding to purge sanitizing solution out of the remaining syrup systems and dispensing valves.
22. Remove potable water source from the syrup system.

#### STEP 5. PURGE WATER OUT OF SYRUP SYSTEMS (RESTORE OPERATION)

23. Syrup Tank Systems.
  - A. Noting syrup tanks CO<sub>2</sub> regulator pressure setting observed in step 4 preceding, readjust CO<sub>2</sub> regulator to the observed pressure setting,
  - B. Connect tanks containing syrup into syrup systems.Bag-in-Box Syrup System.
  - C. Remove all bag valves from bag-in-box syrup containers outlet tubes connectors.
  - D. Connect bag-in-box syrup containers into the syrup systems.
24. Place waste container under dispensing valves. Dispense from all dispensing valves to permit syrup to purge all potable water from the syrup systems and the dispensing valves. Continue to dispense from the dispensing valves until only syrup is dispensed from the syrup systems and valves.



**WARNING: To avoid possible personal injury or property damage, do not attempt to remove the syrup tank cover until CO<sub>2</sub> pressure has been released from the tank.**

25. Dispose of waste sanitizing solution in a sanitary sewer, not in a storm drain, then thoroughly rinse the inside and the outside of the container that was used for sanitizing solution to remove all sanitizing solution residue.

## REPLENISHING CO<sub>2</sub> SUPPLY



**WARNING:** CO<sub>2</sub> displaces oxygen. Strict attention *must* be observed in the prevention of CO<sub>2</sub> (carbon dioxide) gas leaks in the entire CO<sub>2</sub> and soft drink system. If a CO<sub>2</sub> gas leak is suspected, particularly in a small area, *immediately* ventilate the contaminated area before attempting to repair the leak. Personnel exposed to high concentration of CO<sub>2</sub> gas will experience tremors which are followed rapidly by loss of consciousness and suffocation.

**NOTE:** When indicator on CO<sub>2</sub> cylinder primary CO<sub>2</sub> regulator assembly 1800-psi gage is in shaded ("change CO<sub>2</sub> cylinder") portion of dial, CO<sub>2</sub> cylinder is almost empty and should be changed.

1. Fully close (clockwise) CO<sub>2</sub> cylinder valve.
2. Slowly loosen primary CO<sub>2</sub> regulator assembly coupling nut allowing CO<sub>2</sub> pressure to escape, then remove regulator assembly from empty CO<sub>2</sub> cylinder.
3. Unfasten safety chain and remove empty CO<sub>2</sub> cylinder.

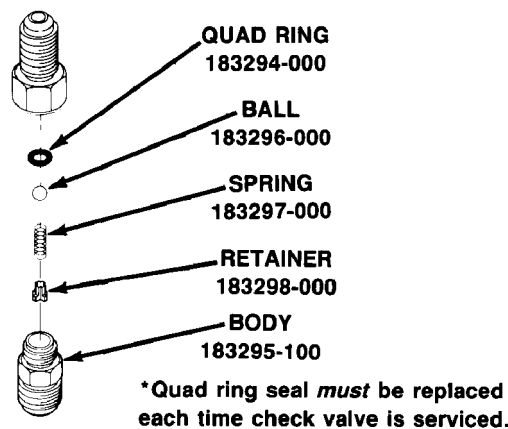

FIGURE 7. CO<sub>2</sub> GAS CHECK VALVE



**WARNING:** To avoid personal injury and/or property damage, always secure CO<sub>2</sub> cylinder in upright position with safety chain to prevent it from falling over. Should valve become accidentally damaged or broken off, CO<sub>2</sub> cylinder can cause serious personal injury.

4. Position CO<sub>2</sub> cylinder and secure with safety chain.
5. Make sure gasket is in place inside primary CO<sub>2</sub> regulator coupling nut, then install regulator on CO<sub>2</sub> cylinder.
6. Open (counterclockwise) CO<sub>2</sub> cylinder valve slightly to allow lines to slowly fill with gas, then open valve fully to back-seat valve. (Back-seating valve prevents leakage around valve shaft).

## REPLENISHING SYRUP SUPPLY

**NOTE:** The following instructions are applicable only when replenishing same flavor syrup. Refer to SYRUP FLAVOR CHANGE when changing syrup flavor.

1. Disconnect empty soft drink tank from syrup system.
2. Check soft drink tank quick disconnects for sticky or restricted operation. Wash disconnects in warm water.

3. Connect full tank of syrup into syrup system.

## **SYRUP FLAVOR CHANGE**

1. Perform sanitizing procedure on syrup system syrup flavor change will be made on.
2. Check soft drink tank quick disconnects for sticky or restricted operation. Wash disconnects in warm water.
3. Connect full tank of new flavor syrup into syrup system.

## **CLEANING CO<sub>2</sub> SYSTEM GAS CHECK VALVES**

### **SECONDARY CO<sub>2</sub> REGULATORS AND CO<sub>2</sub> MANIFOLD CO<sub>2</sub> GAS CHECK VALVES**

(see Figures 2 and 7)

The secondary CO<sub>2</sub> regulators and CO<sub>2</sub> manifold CO<sub>2</sub> gas check valves must be inspected and serviced at least once a year under normal conditions and after any servicing or disruption of the CO<sub>2</sub> system. ALWAYS REPLACE BALL SEAT (QUAD RING SEAL) EACH TIME GAS CHECK VALVES ARE SERVICED.

### **COOLING UNIT CO<sub>2</sub> INLET LINE CO<sub>2</sub> GAS CHECK VALVE**

(see Figures 2 and 7)

CO<sub>2</sub> inlet line CO<sub>2</sub> gas check valve, located inside Cooling Unit, must be inspected and serviced at least once a year under normal conditions and after any servicing or disruption of the CO<sub>2</sub> system. ALWAYS INSTALL NEW BALL SEAT (QUAD RING) SEAL EACH TIME GAS CHECK VALVE IS SERVICED.

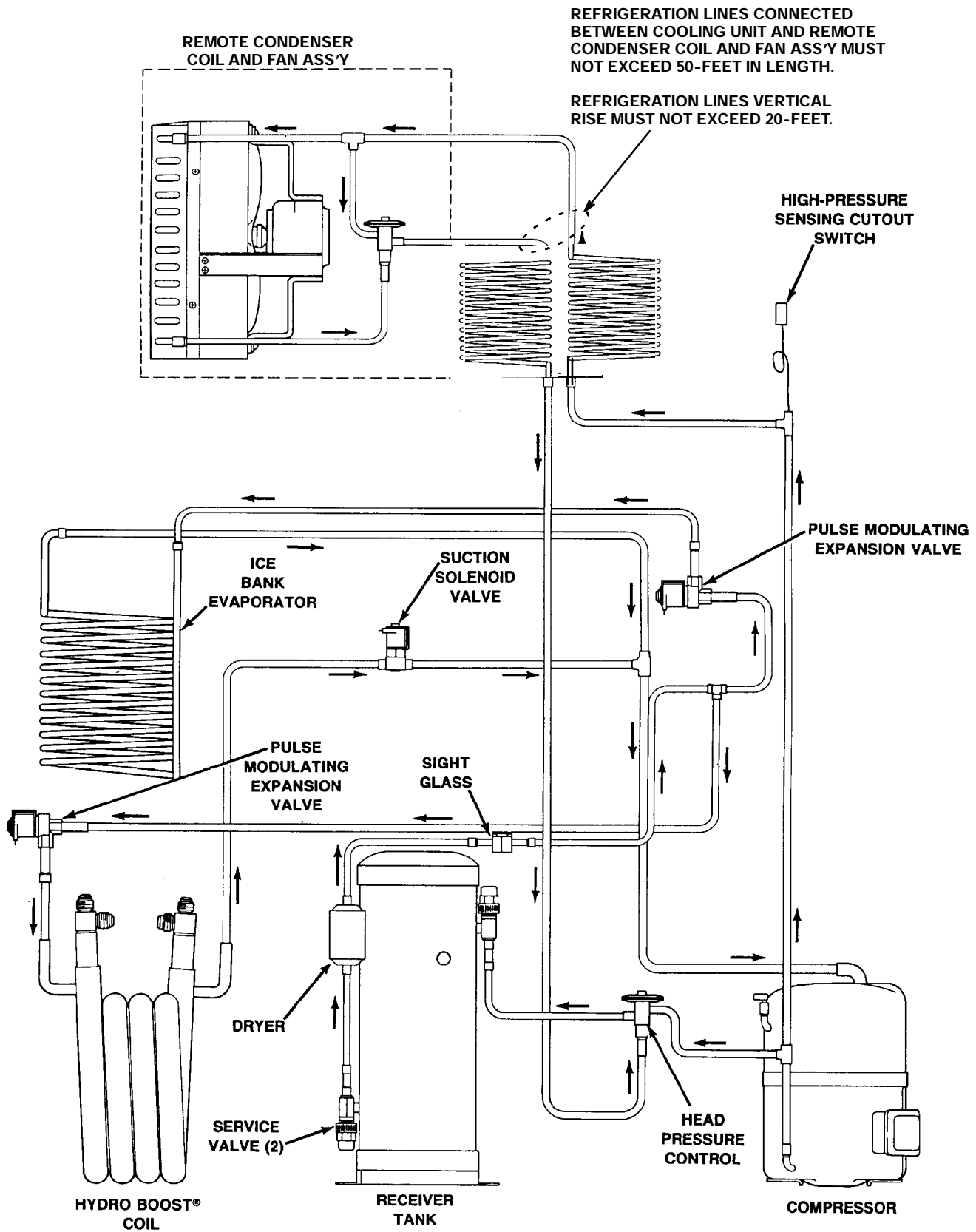
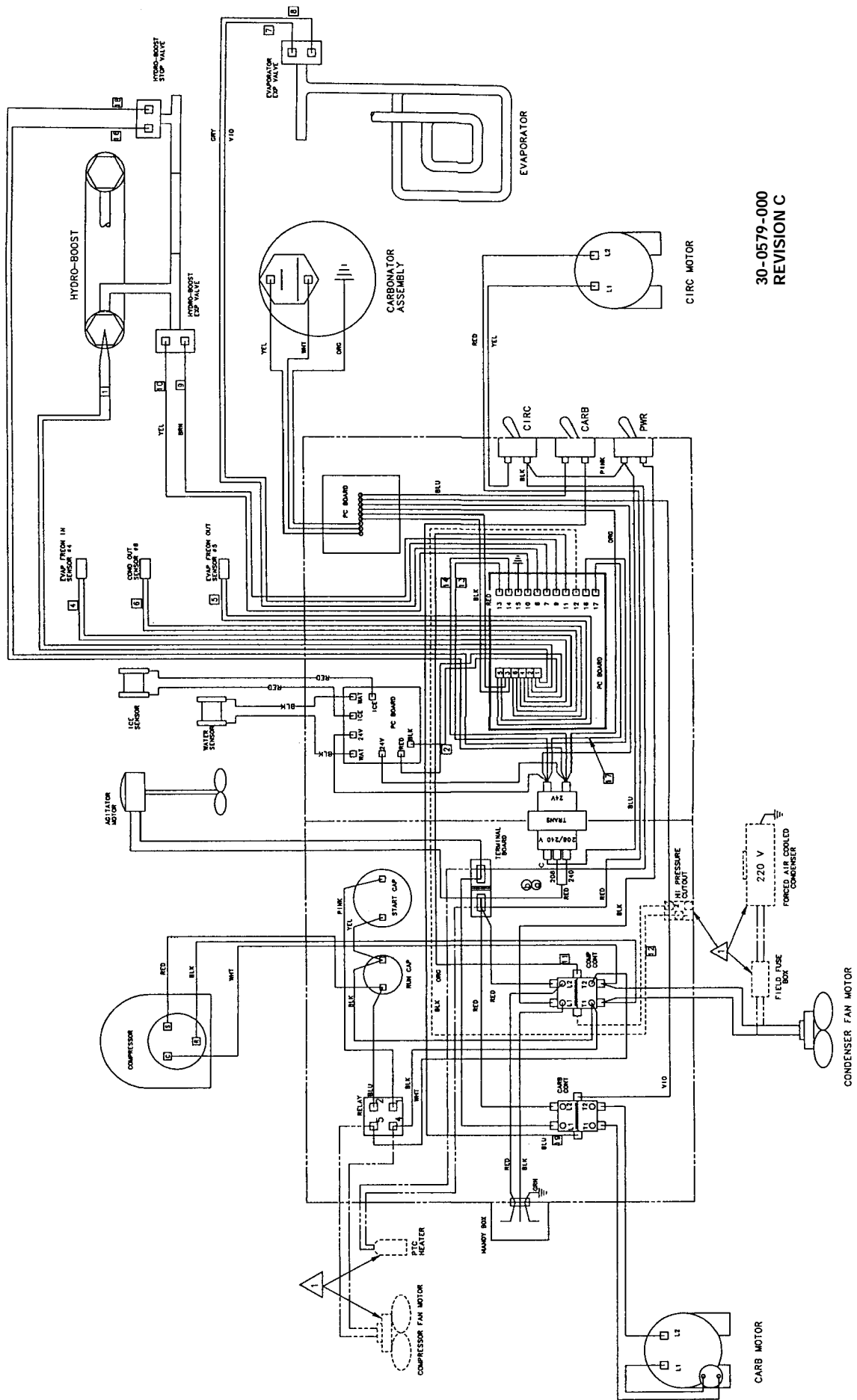

FIGURE 8. REFRIGERATION FLOW DIAGRAM (REQUIRES CONNECTION TO REMOTE CONDENSER COIL AND FAN ASS'Y)





30-0579-000  
REVISION C

FIGURE 9. WIRING DIAGRAM

# TROUBLESHOOTING

**IMPORTANT:** Only qualified personnel should service internal components or electrical wiring.



**WARNING:** If repairs are to be made to a product system, remove quick disconnects from the applicable product tank, then relieve the system pressure before proceeding. If repairs are to be made to the CO<sub>2</sub> system, stop dispensing, shut off the CO<sub>2</sub> supply, then relieve the system pressure before proceeding. If repairs are to be made to the refrigeration system, make sure electrical power is disconnected from the unit.

## TROUBLESHOOTING POSE-MIX SYSTEM

Trouble	Probable Cause	Remedy
WATER-TO-SYRUP "RATIO" OF DISPENSED DRINK TOO LOW OR TOO HIGH.	A. Dispensing valve syrup flow regulator not properly adjusted.	A. Adjust Water-To-Syrup "Ratio" (refer to dispensing station installation Instructions).
	B. CO <sub>2</sub> gas pressure to soft drink tanks insufficient to push syrup out of tanks.	B. Adjust soft drink tanks secondary CO <sub>2</sub> regulator as instructed.
ADJUSTMENT OF DISPENSING VALVE SYRUP FLOW REGULATOR DOES NOT INCREASE TO DESIRED WATER-TO-SYRUP "RATIO".	A. No syrup supply.	A. Replenish syrup supply as instructed.
	B. Soft drink tank quick disconnects not secure.	B. Secure quick disconnects.
	C. Soft drink tanks secondary CO <sub>2</sub> regulator out of adjustment.	C. Adjust soft drink tanks secondary CO <sub>2</sub> regulator as instructed.
	D. Dispensing valve syrup flow regulator, soft drink tank quick disconnect, or syrup line restricted.	D. Sanitize syrup system as instructed.
	E. Tapered nylon washer inside tube swivel nut connector distorted from being overtightened restricting syrup flow.	E. Replace nylon washer. Make sure washer seats properly in swivel nut.
	F. Dirty or inoperative piston or cylinder in dispensing valve syrup flow regulator.	F. Disassemble and clean dispensing valve syrup flow regulator.

Trouble	Probable Cause	Remedy
ADJUSTMENT OF DISPENSING VALVE SYRUP FLOW REGULATOR DOES NOT DECREASE TO DESIRED WATER-TO- SYRUP "RATIO".	A. Dirty or inoperative piston or cylinder in dispensing valve syrup flow regulator.	A. Disassemble and clean dispensing valve syrup flow regulator.
DISPENSED PRODUCT CARBONATION TOO LOW.	A. Carbonator CO <sub>2</sub> regulator out of adjustment for existing water conditions or temperature. B. Water, oil, or dirt in CO <sub>2</sub> supply.	A. Adjust carbonator CO <sub>2</sub> regulator as instructed. B. Remove contaminated CO <sub>2</sub> supply. Clean CO <sub>2</sub> system (lines, regulators, etc.) using a mild detergent. Replenish with a clean CO <sub>2</sub> supply.
DISPENSED PRODUCT COMES OUT OF DISPENSING VALVE CLEAR BUT FOAMS IN CUP.	A. Oil film or soap scum in cups. B. Ice used for finished drink is sub-cooled.	A. Use clean cups. B. Do not use ice directly from freezer. Allow ice to become "wet" before using. (Refer to following NOTE)
<b>NOTE: Crushed ice also causes dispensing problems. When finished drink hits sharp edges of ice, carbonation is released from finished drink.</b>		
DISPENSED PRODUCT PRODUCES FOAM AS IT LEAVES DISPENSING VALVE.	A. Carbonator CO <sub>2</sub> regulator pressure set too high for existing water conditions or temperature. B. Syrup over-carbonated with CO <sub>2</sub> . C. Tapered nylon washer inside tube swivel nut connection distorted from being overtightened restricting syrup flow.	A. Reduce carbonator CO <sub>2</sub> regulator pressure setting as instructed. B. Remove soft drink tank quick disconnects. Relieve tank CO <sub>2</sub> pressure, shake tank vigorously, then relieve tank CO <sub>2</sub> pressure as many times as necessary to remove over-carbonation. C. Replace nylon washer. Make sure washer is properly seated in swivel nut.
ONLY CARBONATED WATER DISPENSED.	A. Quick disconnect not secure on soft drink tank. B. Out of syrup. C. Inoperable Dispensing Station. D. Dispensing valve syrup flow regulator not properly adjusted.	A. Secure quick disconnect on soft drink tank. B. Replenish syrup supply as instructed. C. Repair Dispensing Station. D. Adjust dispensing valve syrup flow regulator (refer to Installation Instructions provided with Dispensing Station).

Trouble	Probable Cause	Remedy
ONLY CARBONATED WATER DISPENSED (con't).	E. Dispensing valve syrup flow regulator, soft drink tank quick disconnect, or syrup lines restricted.	E. Sanitize syrup system as instructed.
ONLY SYRUP DISPENSED.	A. Plain water inlet supply line shutoff valve closed. B. CARBONATOR MOTOR power switch in "OFF" position. C. Water filter clogged.	A. Open plain water inlet supply line shutoff valve. B. Place switch in "ON" position. C. Replace water filter.
WARM PRODUCT BEING DISPENSED.	A. Carbonated water circulating pump CIRCULATING MOTOR power switch in "OFF" position. B. Inoperable carbonated water circulating pump or motor.	A. Place circulating pump CIRCULATING MOTOR power switch in "ON" position. B. Replace pump or motor.
WATER PUMP MOTOR WILL NOT OPERATE.	A. Inoperative water pump motor. B. Water safety thermostat inoperative. C. Loose connections and/or open electrical circuit. D. Overheated motor cut off by thermal overload protector. E. Water pump binding (new or replacement pumps only.) F. Inoperative liquid level sensing probe. G. Inoperative liquid level sensing PC board. H. No 24 VAC to liquid level sensing PC board.	A. Replace water pump motor. B. Replace safety thermostat. C. Tighten connections and/or repair open circuit. D. Check for proper line voltage. Check for restricted pump discharge. E. Remove water pump from motor, rotate pump or motor shaft 180 degrees, then recouple pump to motor. F. Replace liquid level sensing probe. G. Replace liquid level sensing PC board. H. Check electrical wiring and transformer for 24 VAC output.
WATER PUMP MOTOR WILL NOT SHUT OFF.	A. Inoperative liquid level sensing probe. B. Inoperative liquid level sensing PC board. C. Liquid level sensing probe wired wrong. D. Leak in carbonated water system.	A. Replace liquid level sensing probe. B. Replace liquid level sensing PC board. C. Correct liquid sensing probe wiring. D. Repair leak in carbonated water system.
ERRATIC CYCLING OF CARBONATOR.	A. Inoperative liquid level sensing probe. B. Inoperative liquid level sensing PC board.	A. Replace liquid level sensing probe. B. Replace liquid level sensing PC board.

Trouble	Probable Cause	Remedy
ERRATIC CYCLING OF CARBONATOR (con't).	C. Liquid level sensing probe wired wrong.	C. Correct liquid level sensing probe wiring.
	D. Dirty or oily liquid level sensing probe.	D. Clean liquid level sensing probe.
WATER PUMP MOTOR OPERATES BUT WATER PUMP DOES NOT PUMP WATER.	A. Water inlet supply line shutoff valve closed.	A. Open water inlet supply line shutoff valve.
	B. Kinked water inlet supply line.	B. Straighten water inlet supply line.
	C. Restriction between water pump outlet and carbonator tank inlet.	C. Remove restriction.
	D. Foreign object in water pump bypass.	D. Clean bypass. (Note: Count number of turns bypass screw makes when removing and install same number of turns).
	E. Water pump worn out.	E. Replace water pump.
WATER PUMP CAPACITY TOO LOW.	A. Water supply capacity too low.	A. Water inlet supply must be at a minimum of 300-gallons per hour with a maximum water pressure of 80-psi.
	B. Water filter clogged.	B. Replace water filter cartridge as instructed.
	C. Inoperative water pump.	C. Replace water pump.

### TROUBLESHOOTING REFRIGERATION SYSTEM

COMPRESSOR DOES NOT OPERATE.	A. Ice bank sufficient.	A. Refrigeration not called for.
	B. REFRIGERATION POWER switch in "OFF" position.	B. Place REFRIGERATION POWER switch in "ON" position.
	C. Electrical power to Cooling Unit turned off.	C. Turn on electrical power to Cooling Unit.
	D. No Cooling Unit power source. Blown fuse or tripped circuit breaker.	D. Replace fuse or reset circuit breaker.
	E. Loose, disconnected, or broken wiring.	E. Tighten connections or replace broken wiring.
	F. Hi-pressure cutout switch tripped.	F. Reset pressure switch (see REFRIGERATION SYSTEM TEMPERATURE SENSING DEVICE AND HIGH-PRESSURE CUTOUT SWITCH in OPERATORS INSTRUCTIONS SECTION).
	G. Low Voltage.	G. Voltage must be at least 208 volts at compressor terminals when compressor is trying to start.
	H. Inoperable run capacitor, start capacitor, or relay.	H. Replace inoperable part.
	I. Inoperable compressor.	I. Replace compressor.

Trouble	Probable Cause	Remedy
COMPRESSOR DOES NOT OPERATE (con't).	J. Inoperable control board	J. Replace control board.
	K. Inoperable contactor	K. Replace contactor.
	L. No voltage to control board.	L. Check for loose or broken wiring. Check 240/24 VAC power transformer for 24 VAC output. (see NOTE below).
	M. Inoperable control board or water/ice sensor PC board.	M. Replace control board.
	N. Inoperable ICE SENSOR.	N. Replace ICE SENSOR.
	O. EVAP IN, COND OUT, or EVAP OUT sensor is open, shorted, or out of temperature range.	O. Replace inoperable sensor.
	P. Hydro Boostâ WATER SENSOR is shorted or open circuit.	P. Check for loose, broken, or disconnected wire or plug at pre-cool coil. Repair or replace wire or secure plug. If Hydro Boostâ WATER SENSOR is inoperable, replace sensor.

**NOTE: Confirm which sensor has failed by using the Aurora Series System Analyzer (P/N 309197-000).**

**NOTE: The 240/24 VAC power transformer has an overload reset button located on its 24 VAC output side (see Figure 3). An overload on the transformer will cause its reset button to pop out disrupting the 24 VAC output to the main control board. Overload button must be pressed in to restore 24 VAC output.**

COMPRESSOR OPERATES CONTINUOUSLY BUT DOES NOT FORM SUFFICIENT ICE BANK	A. Cooling capacity is exceeded by overdrawing.	A. Reduce amount of drinks drawn per given time.
	B. Air circulation through Remote Condenser Coil and Fan Assembly Condenser Coil is restricted.	B. Check and if necessary, clean condenser coil as instructed.
	C. Insufficient refrigerant charge.	C. Check Cooling Unit sight glass for bubbles or liquid break. Find and repair refrigeration leak, the replenish refrigerant charge.
	D. Inoperative or disconnected pulse-modulating expansion valve (see REFRIGERATION FLOW DIAGRAM).	D. Check that expansion valve is operating by touch (should be able to feel valve pulse).  Check for loose or disconnected wire to solenoid coil. If necessary, troubleshoot expansion valve with a gage set to see if it is opening. If expansion valve is not opening, suction pressure will be in a vacuum.

Trouble	Probable Cause	Remedy
COMPRESSOR OPERATES CONTINUOUSLY BUT DOES NOT FORM SUFFICIENT ICE BANK (con't).	E. Inoperative control board. No output from board to solenoids.	E. Check LED's on control board to see if they are modulating. Check for 24V output to pulse modulating expansion valve (see WIRING DIAGRAM).  If control board green LED is on and yellow LED is flashing; but no 24V output, replace board.
CONDENSER FAN MOTOR NOT OPERATING	A. Blown power circuit fuse. B. Fan blade obstructed. C. Inoperative condenser fan motor. D. Compressor contactor inoperable.	A. Replace power circuit fuse. B. Remove obstruction. C. Replace condenser fan motor. D. Replace compressor contactor.
AGITATOR MOTOR NOT OPERATING.	A. Agitator motor propeller obstructed. B. Low voltage. C. Loose, disconnected, or broken wiring. D. Inoperative agitator motor.	A. Remove obstruction. B. Voltage must be at least 208 volts at compressor terminals when compressor is trying to start. C. Tighten connections or replace broken wiring. D. Replace agitator motor.

# WARRANTY

IMI Cornelius Inc. warrants that all equipment and parts are free from defects in material and workmanship under normal use and service. For a copy of the warranty applicable to your Cornelius, Remcor or Wilshire product, in your country, please write, fax or telephone the IMI Cornelius office nearest you. Please provide the equipment model number, serial number and the date of purchase.

## IMI Cornelius Offices

AUSTRALIA • P.O. 210, • RIVERWOOD, • NSW 2210, AUSTRALIA • (61) 2 533 3122 • FAX (61) 2 534 2166  
AUSTRIA • AM LANGEN FELDE 32 • A-1222 • VIENNA, AUSTRIA • (43) 1 233 520 • FAX (43) 1-2335-2930  
BELGIUM • BOSKAPELLEI 122 • B-2930 BRAASCHAAT, BELGIUM • (32) 3 664 0552 • FAX (32) 3 665 2307  
BRAZIL • RUA ITAOCARA 97 • TOMAS COELHO • RIO DE JANEIRO, BRAZIL • (55) 21 591 7150 • FAX (55) 21 593 1829  
ENGLAND • TYTHING ROAD ALCESTER • WARWICKSHIRE, B49 6 EU, ENGLAND • (44) 789 763 101 • FAX (44) 789 763 644  
FRANCE • 71 ROUTE DE ST. DENIS • F-95170 DEUIL LA BARRE • PARIS, FRANCE • (33) 1 34 28 6200 • FAX (33) 1 34 28 6201  
GERMANY • CARL LEVERKUS STRASSE 15 • D-4018 LANGENFELD, GERMANY • (49) 2173 7930 • FAX (49) 2173 77 438  
GREECE • 488 MESSOGION AVENUE • AGIA PARASKEVI • 153 42 • ATHENS, GREECE • (30) 1 600 1073 • FAX (30) 1 601 2491  
HONG KONG • 1104 TAIKOTSUI CENTRE • 11-15 KOK CHEUNG ST • TAIKOKTSUE, HONG KONG • (852) 789 9882 • FAX (852) 391 6222  
ITALY • VIA PELLIZZARI 11 • I-20059 • VIMARCATI, ITALY • (39) 39 608 0817 • FAX (39) 39 608 0814  
NEW ZEALAND • 20 LANSFORD CRES. • P.O. BOX 19-044 AVONDALE • AUCKLAND 7, NEW ZEALAND • (64) 9 8200 357 • FAX (64) 9 8200 361  
SINGAPORE • 16 TUAS STREET • SINGAPORE 2263 • (65) 862 5542 • FAX (65) 862 5604  
SPAIN • POLIGONO INDUSTRIAL • RIERA DEL FONOLLAR • E-08830 SANT BOI DE LLOBREGAT • BARCELONA, SPAIN • (34) 3 640 2839 • FAX (34) 3 654 3379  
USA • ONE CORNELIUS PLACE • ANOKA, MINNESOTA • (612) 421-6120 • FAX (612) 422-3255

LD004  
4/21/98



THIS PAGE LEFT BLANK INTENTIONALLY

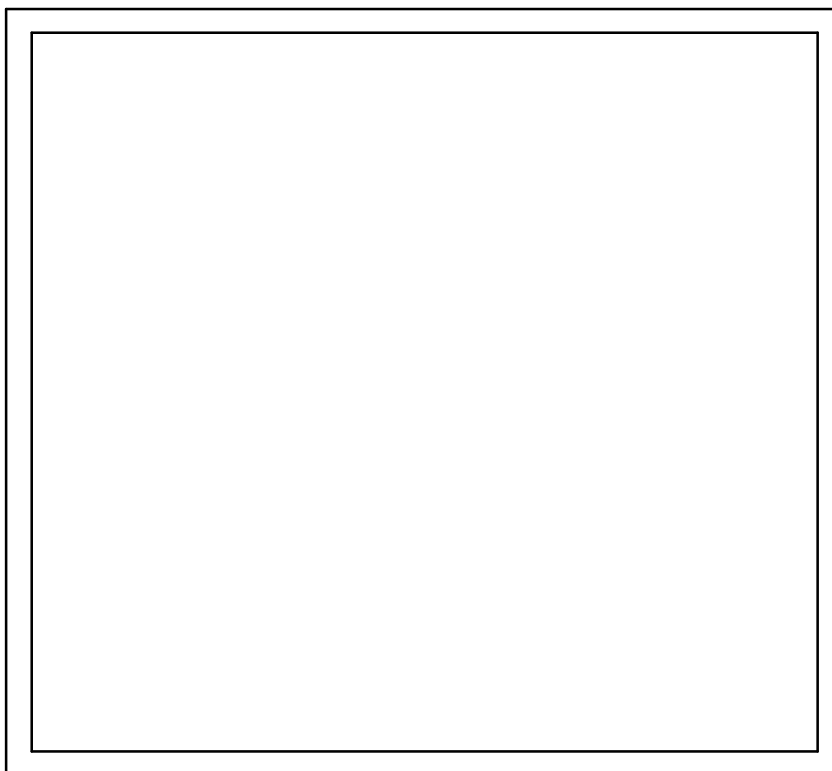

**IMI CORNELIUS INC.**

---

**CORPORATE HEADQUARTERS:**

**One Cornelius Place  
Anoka, Minnesota 55303-6234  
(612) 421-6120  
(800) 238-3600**

