

PXI Express™

NI PXIe-1082DC User Manual

Worldwide Technical Support and Product Information

ni.com

Worldwide Offices

Visit ni.com/niglobal to access the branch office websites, which provide up-to-date contact information, support phone numbers, email addresses, and current events.

National Instruments Corporate Headquarters

11500 North Mopac Expressway Austin, Texas 78759-3504 USA Tel: 512 683 0100

For further support information, refer to the [NI Services](#) appendix. To comment on National Instruments documentation, refer to the National Instruments website at ni.com/info and enter the Info Code [feedback](#).

Legal Information

Limited Warranty

This document is provided 'as is' and is subject to being changed, without notice, in future editions. For the latest version, refer to ni.com/manuals. NI reviews this document carefully for technical accuracy; however, NI MAKES NO EXPRESS OR IMPLIED WARRANTIES AS TO THE ACCURACY OF THE INFORMATION CONTAINED HEREIN AND SHALL NOT BE LIABLE FOR ANY ERRORS.

NI warrants that its hardware products will be free of defects in materials and workmanship that cause the product to fail to substantially conform to the applicable NI published specifications for one (1) year from the date of invoice.

For a period of ninety (90) days from the date of invoice, NI warrants that (i) its software products will perform substantially in accordance with the applicable documentation provided with the software and (ii) the software media will be free from defects in materials and workmanship.

If NI receives notice of a defect or non-conformance during the applicable warranty period, NI will, in its discretion: (i) repair or replace the affected product, or (ii) refund the fees paid for the affected product. Repaired or replaced Hardware will be warranted for the remainder of the original warranty period or ninety (90) days, whichever is longer. If NI elects to repair or replace the product, NI may use new or refurbished parts or products that are equivalent to new in performance and reliability and are at least functionally equivalent to the original part or product.

You must obtain an RMA number from NI before returning any product to NI. NI reserves the right to charge a fee for examining and testing Hardware not covered by the Limited Warranty.

This Limited Warranty does not apply if the defect of the product resulted from improper or inadequate maintenance, installation, repair, or calibration (performed by a party other than NI); unauthorized modification; improper environment; use of an improper hardware or software key; improper use or operation outside of the specification for the product; improper voltages; accident, abuse, or neglect; or a hazard such as lightning, flood, or other act of nature.

THE REMEDIES SET FORTH ABOVE ARE EXCLUSIVE AND THE CUSTOMER'S SOLE REMEDIES, AND SHALL APPLY EVEN IF SUCH REMEDIES FAIL OF THEIR ESSENTIAL PURPOSE.

EXCEPT AS EXPRESSLY SET FORTH HEREIN, PRODUCTS ARE PROVIDED "AS IS" WITHOUT WARRANTY OF ANY KIND AND NI DISCLAIMS ALL WARRANTIES, EXPRESSED OR IMPLIED, WITH RESPECT TO THE PRODUCTS, INCLUDING ANY IMPLIED WARRANTIES OF MERCHANTABILITY, FITNESS FOR A PARTICULAR PURPOSE, TITLE OR NON-INFRINGEMENT, AND ANY WARRANTIES THAT MAY ARISE FROM USAGE OF TRADE OR COURSE OF DEALING. NI DOES NOT WARRANT, GUARANTEE, OR MAKE ANY REPRESENTATIONS REGARDING THE USE OF OR THE RESULTS OF THE USE OF THE PRODUCTS IN TERMS OF CORRECTNESS, ACCURACY, RELIABILITY, OR OTHERWISE. NI DOES NOT WARRANT THAT THE OPERATION OF THE PRODUCTS WILL BE UNINTERRUPTED OR ERROR FREE.

In the event that you and NI have a separate signed written agreement with warranty terms covering the products, then the warranty terms in the separate agreement shall control.

Copyright

Under the copyright laws, this publication may not be reproduced or transmitted in any form, electronic or mechanical, including photocopying, recording, storing in an information retrieval system, or translating, in whole or in part, without the prior written consent of National Instruments Corporation.

National Instruments respects the intellectual property of others, and we ask our users to do the same. NI software is protected by copyright and other intellectual property laws. Where NI software may be used to reproduce software or other materials belonging to others, you may use NI software only to reproduce materials that you may reproduce in accordance with the terms of any applicable license or other legal restriction.

End-User License Agreements and Third-Party Legal Notices

You can find end-user license agreements (EULAs) and third-party legal notices in the following locations:

- Notices are located in the <National Instruments>_Legal Information and <National Instruments> directories.
- EULAs are located in the <National Instruments>\Shared\MDF\Legal\license directory.
- Review <National Instruments>_Legal Information.txt for information on including legal information in installers built with NI products.

U.S. Government Restricted Rights

If you are an agency, department, or other entity of the United States Government ("Government"), the use, duplication, reproduction, release, modification, disclosure or transfer of the technical data included in this manual is governed by the Restricted Rights provisions under Federal Acquisition Regulation 52.227-14 for civilian agencies and Defense Federal Acquisition Regulation Supplement Section 252.227-7014 and 252.227-7015 for military agencies.

Trademarks

Refer to the *NI Trademarks and Logo Guidelines* at ni.com/trademarks for more information on National Instruments trademarks.

ARM, Keil, and μ Vision are trademarks or registered of ARM Ltd or its subsidiaries.

LEGO, the LEGO logo, WEDO, and MINDSTORMS are trademarks of the LEGO Group.

TETRIX by Pitsco is a trademark of Pitsco, Inc.

FIELDBUS FOUNDATION™ and FOUNDATION™ are trademarks of the Fieldbus Foundation.

EtherCAT® is a registered trademark of and licensed by Beckhoff Automation GmbH.

CANopen® is a registered Community Trademark of CAN in Automation e.V.

DeviceNet™ and EtherNet/IP™ are trademarks of ODVA.

Go!, SensorDAQ, and Vernier are registered trademarks of Vernier Software & Technology. Vernier Software & Technology and vernier.com are trademarks or trade dress.

Xilinx is the registered trademark of Xilinx, Inc.

Taprite and Trilobular are registered trademarks of Research Engineering & Manufacturing Inc.

FireWire® is the registered trademark of Apple Inc.

Linux® is the registered trademark of Linus Torvalds in the U.S. and other countries.

Handle Graphics®, MATLAB®, Real-Time Workshop®, Simulink®, Stateflow®, and xPC TargetBox® are registered trademarks, and TargetBox™ and Target Language Compiler™ are trademarks of The MathWorks, Inc.

Tektronix®, Tek, and Tektronix, Enabling Technology are registered trademarks of Tektronix, Inc.

The Bluetooth® word mark is a registered trademark owned by the Bluetooth SIG, Inc.

The ExpressCard™ word mark and logos are owned by PCMCIA and any use of such marks by National Instruments is under license.

The Mark Lab Windows is used under a license from Microsoft Corporation. Windows is a registered trademark of Microsoft Corporation in the United States and other countries.

Other product and company names mentioned herein are trademarks or trade names of their respective companies.

Members of the National Instruments Alliance Partner Program are business entities independent from National Instruments and have no agency, partnership, or joint-venture relationship with National Instruments.

Patents

For patents covering National Instruments products/technology, refer to the appropriate location: **Help»Patents** in your software, the `patents.txt` file on your media, or the *National Instruments Patent Notice* at ni.com/patents.

Export Compliance Information

Refer to the *Export Compliance Information* at ni.com/legal/export-compliance for the National Instruments global trade compliance policy and how to obtain relevant HTS codes, ECCNs, and other import/export data.

WARNING REGARDING USE OF NATIONAL INSTRUMENTS PRODUCTS

YOU ARE ULTIMATELY RESPONSIBLE FOR VERIFYING AND VALIDATING THE SUITABILITY AND RELIABILITY OF THE PRODUCTS WHENEVER THE PRODUCTS ARE INCORPORATED IN YOUR SYSTEM OR APPLICATION, INCLUDING THE APPROPRIATE DESIGN, PROCESS, AND SAFETY LEVEL OF SUCH SYSTEM OR APPLICATION.

PRODUCTS ARE NOT DESIGNED, MANUFACTURED, OR TESTED FOR USE IN LIFE OR SAFETY CRITICAL SYSTEMS, HAZARDOUS ENVIRONMENTS OR ANY OTHER ENVIRONMENTS REQUIRING FAIL-SAFE PERFORMANCE, INCLUDING IN THE OPERATION OF NUCLEAR FACILITIES; AIRCRAFT NAVIGATION; AIR TRAFFIC CONTROL SYSTEMS; LIFE SAVING OR LIFE SUSTAINING SYSTEMS OR SUCH OTHER MEDICAL DEVICES; OR ANY OTHER APPLICATION IN WHICH THE FAILURE OF THE PRODUCT OR SERVICE COULD LEAD TO DEATH, PERSONAL INJURY, SEVERE PROPERTY DAMAGE OR ENVIRONMENTAL HARM (COLLECTIVELY, "HIGH-RISK USES"). FURTHER, PRUDENT STEPS MUST BE TAKEN TO PROTECT AGAINST FAILURES, INCLUDING PROVIDING BACK-UP AND SHUT-DOWN MECHANISMS. NI EXPRESSLY DISCLAIMS ANY EXPRESS OR IMPLIED WARRANTY OF FITNESS OF THE PRODUCTS OR SERVICES FOR HIGH-RISK USES.

Compliance



Caution This icon denotes a caution, which advises you of precautions to take to avoid injury, data loss, or a system crash. When this symbol is marked on the product, refer to the *Read Me First: Safety and Electromagnetic Compatibility* document, shipped with the product, for precautions to take.

Electromagnetic Compatibility Information

This hardware has been tested and found to comply with the applicable regulatory requirements and limits for electromagnetic compatibility (EMC) as indicated in the hardware's Declaration of Conformity (DoC)¹. These requirements and limits are designed to provide reasonable protection against harmful interference when the hardware is operated in the intended electromagnetic environment. In special cases, for example when either highly sensitive or noisy hardware is being used in close proximity, additional mitigation measures may have to be employed to minimize the potential for electromagnetic interference.

While this hardware is compliant with the applicable regulatory EMC requirements, there is no guarantee that interference will not occur in a particular installation. To minimize the potential for the hardware to cause interference to radio and television reception or to experience unacceptable performance degradation, install and use this hardware in strict accordance with the instructions in the hardware documentation and the DoC¹.

If this hardware does cause interference with licensed radio communications services or other nearby electronics, which can be determined by turning the hardware off and on, you are encouraged to try to correct the interference by one or more of the following measures:

- Reorient the antenna of the receiver (the device suffering interference).
- Relocate the transmitter (the device generating interference) with respect to the receiver.
- Plug the transmitter into a different outlet so that the transmitter and the receiver are on different branch circuits.

Some hardware may require the use of a metal, shielded enclosure (windowless version) to meet the EMC requirements for special EMC environments such as, for marine use or in heavy industrial areas. Refer to the hardware's user documentation and the DoC¹ for product installation requirements.

When the hardware is connected to a test object or to test leads, the system may become more sensitive to disturbances or may cause interference in the local electromagnetic environment.

Operation of this hardware in a residential area is likely to cause harmful interference. Users are required to correct the interference at their own expense or cease operation of the hardware.

Changes or modifications not expressly approved by National Instruments could void the user's right to operate the hardware under the local regulatory rules.

¹ The Declaration of Conformity (DoC) contains important EMC compliance information and instructions for the user or installer. To obtain the DoC for this product, visit ni.com/certification, search by model number or product line, and click the appropriate link in the Certification column.

Contents

About This Manual

Related Documentation	ix
-----------------------------	----

Chapter 1 Getting Started

Unpacking.....	1-1
What You Need to Get Started	1-1
Key Features	1-1
Chassis Description	1-3
Optional Equipment.....	1-4
Rack Mount Kit	1-4
NI PXIe-1082DC Chassis Backplane Overview	1-5
Interoperability with CompactPCI.....	1-5
System Controller Slot.....	1-6
Hybrid Peripheral Slots	1-6
PXI Express Peripheral Slots.....	1-6
System Timing Slot	1-7
PXI Local Bus	1-8
PXI Trigger Bus.....	1-9
System Reference Clock.....	1-9
PXIe_SYNC_CTRL	1-11

Chapter 2 Installation and Configuration

Safety Information	2-1
Chassis Cooling Considerations	2-2
Providing Adequate Clearance	2-2
Chassis Ambient Temperature Definition	2-3
Setting Fan Speed	2-3
Rack Mounting	2-3
Connecting Safety Ground	2-4
Connecting to Power Source	2-4
Installing a PXI Express System Controller	2-4
Installing Peripheral Modules.....	2-6
Power Inhibit Switch LED Indicator	2-8
Remote Voltage Monitoring and Control	2-8
Inhibit Mode Switch	2-10
PXI_CLK10 Rear Connectors	2-10
PXI Express System Configuration with MAX	2-10
PXI-1 System Configuration	2-11
Using System Configuration and Initialization Files	2-12

Chapter 3 Maintenance

Service Interval	3-1
Preparation	3-1
Cleaning	3-1
Interior Cleaning	3-1
Exterior Cleaning	3-2
Resetting the DC Mains Circuit Breaker	3-2
Replacing the Modular Power Supply	3-3
Removal	3-3
Installation	3-3
Configuration	3-3
Connecting to Power Source	3-3

Appendix A Specifications

Appendix B Pinouts

System Controller Slot Pinouts	B-1
System Timing Slot Pinouts	B-4
Hybrid Slot Pinouts	B-6

Appendix C NI Services

Glossary

Index

About This Manual

The *NI PXIe-1082DC User Manual* describes the features of the NI PXIe-1082DC chassis and contains information about configuring the chassis, installing the modules, and operating the chassis.

Related Documentation

The following documents contain information that you might find helpful as you read this manual:

- IEEE 1101.1-1991, *IEEE Standard for Mechanical Core Specifications for Microcomputers Using IEC 603-2 Connectors*
- IEEE 1101.10, *IEEE Standard for Additional Mechanical Specifications for Microcomputers Using IEEE 1101.1 Equipment Practice*
- *PICMG EXP.0 R1.0 CompactPCI Express Specification*, PCI Industrial Computers Manufacturers Group
- *PCI Express Base Specification*, Revision 2.0, PCI Special Interest Group
- *PXI-5 PXI Express Hardware Specification*, Revision 1.0, PXI Systems Alliance

Getting Started

This chapter describes the key features of the NI PXIe-1082DC chassis and lists the kit contents and optional equipment you can order from National Instruments.

Unpacking

Carefully inspect the shipping container and the chassis for damage. Check for visible damage to the metal work. Check to make sure all handles, hardware, and switches are undamaged. Inspect the inner chassis for any possible damage, debris, or detached components. If damage appears to have been caused during shipment, file a claim with the carrier. Retain the packing material for possible inspection and/or reshipment.

What You Need to Get Started

The NI PXIe-1082DC chassis kit contains the following items:

- NI PXIe-1082DC chassis
- Filler panels
- DC power cable—Tyco Electronics 9 ft., 60 A, Part Number 60DBPL
- [NI PXIe-1082DC User Manual](#)
- Software media with *PXI Platform Services 2.0* or higher
- Read Me First: Safety and Electromagnetic Compatibility*
- Chassis number labels

Key Features

The NI PXIe-1082DC chassis combines a high-performance 8-slot PXI Express backplane with a high-output power supply and a structural design that has been optimized for maximum usability in a wide range of applications. The chassis' modular design ensures a high level of maintainability, resulting in a very low mean time to repair (MTTR). The NI PXIe-1082DC chassis fully complies with the *PXI-5 PXI Express Hardware Specification*, offering advanced timing and synchronization features.

The key features of the NI PXIe-1082DC chassis include the following:

- High Performance for Instrumentation Requirements
 - Up to 1 GB/s (single direction) per PXI Express slot dedicated bandwidth (x4 PCIe)
 - 38 W per slot cooling meets increased PXIe cooling requirements
 - Low-jitter internal 10 MHz reference clock for PXI slots with ± 25 ppm stability
 - Low-jitter internal 100 MHz reference clock for PXIe slots with ± 25 ppm stability
 - Quiet operation for 0 to 30 °C at 48.7 dBA
 - Variable speed fan controller optimizes cooling and acoustic emissions
 - Remote power-inhibit control
 - Complies with PXI and CompactPCI Specifications
- High Reliability
 - 0 to 55 °C extended temperature range
 - Power supply, temperature, and fan monitoring
 - HALT tested for increased reliability
 - Field replaceable power supply shuttle
- Multi-Chassis Support
 - PXIe System Timing Slot for tight synchronization across chassis
 - Rear CLK10 I/O connectors
 - Switchless CLK10 routing
- Optional Features
 - Front and rear rack-mount kits
 - Replacement power supply shuttle
 - EMC filler panels
 - Slot blockers for improved cooling performance
 - System Assurance Plans

Chassis Description

Figures 1-1 and 1-2 show the key features of the NI PXIe-1082DC chassis front and back panels. Figure 1-1 shows the front view of the NI PXIe-1082DC. Figure 1-2 shows the rear view of the NI PXIe-1082DC.

Figure 1-1. Front View of the NI PXIe-1082DC Chassis

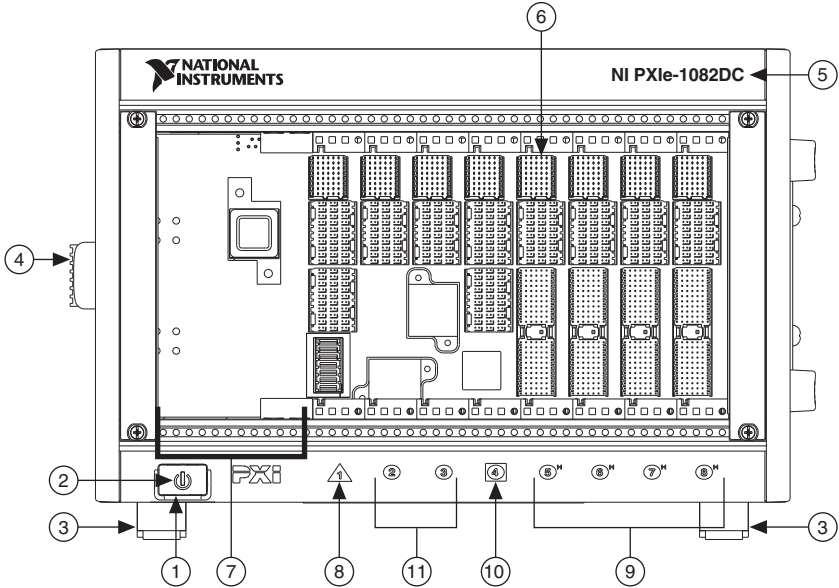

- | | |
|----------------------------|---------------------------------------|
| 1 Power Inhibit Switch | 7 System Controller Expansion Slots |
| 2 Power Inhibit Switch LED | 8 PXI Express System Controller Slot |
| 3 Removable Foot | 9 PXI Express Hybrid Peripheral Slots |
| 4 Chassis Carry Handle | 10 PXI Express System Timing Slot |
| 5 Chassis Model Name | 11 PXI Express Peripheral Slot |
| 6 Backplane Connectors | |

Figure 1-2. Rear View of the NI PXIe-1082DC Chassis

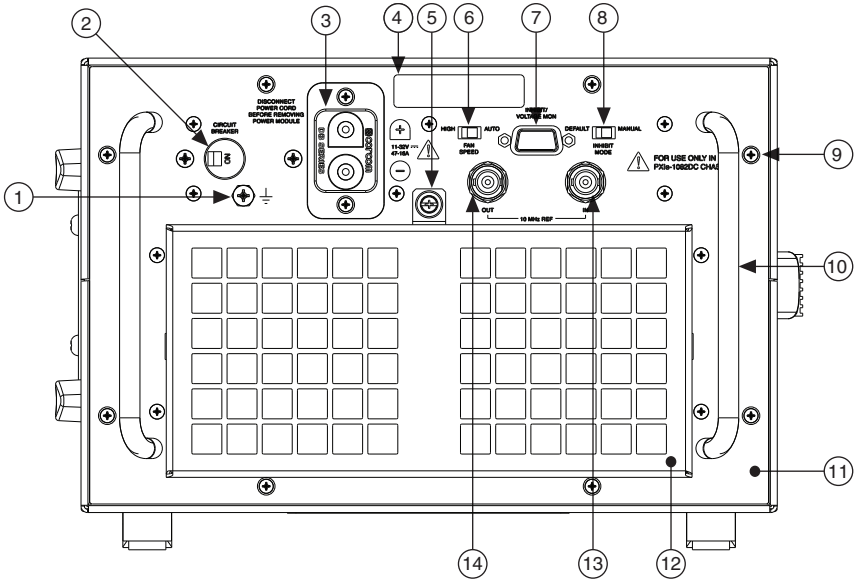

- | | |
|---|---|
| 1 Chassis Ground Screw | 8 Inhibit Mode Selector Switch |
| 2 Circuit Breaker Switch | 9 Power Supply Shuttle Mounting Screws (x8) |
| 3 Universal DC Input | 10 Power Supply Shuttle Handle (x2) |
| 4 Power Supply Shuttle ID Label | 11 Power Supply Shuttle |
| 5 Air Filter Retainer Screw | 12 Air Filter Retainer |
| 6 Fan Speed Selector Switch | 13 10 MHz REF IN BNC |
| 7 Remote Inhibit and Voltage Monitoring Connector | 14 10 MHz REF OUT BNC |

Optional Equipment

Contact National Instruments to order the following option for the NI PXIe-1082DC chassis.

Rack Mount Kit

There are two optional kits for mounting the NI PXIe-1082DC chassis into a rack. The first option is a pair of mounting brackets for use on the front of the chassis. The second option is a rear rack mount kit. The rear rack mount kit differs from the front kit to allow for easier installation into the rack. For more information, refer to Figure A-3, [NI Chassis Rack Mount Kit Components](#).

NI PXIe-1082DC Chassis Backplane Overview

This section provides an overview of the backplane features for the NI PXIe-1082DC chassis.

Interoperability with CompactPCI

The design of the NI PXIe-1082DC provides you the flexibility to use the following devices in a single PXI Express chassis:

- PXI Express compatible products
- CompactPCI Express compatible 4-Link system controller products
- CompactPCI Express compatible Type-2 peripheral products
- PXI peripheral products
- Standard CompactPCI peripheral products

Refer to Figure 1-3 for an overview of the NI PXIe-1082DC architecture.

Figure 1-3. NI PXIe-1082DC Backplane Architecture

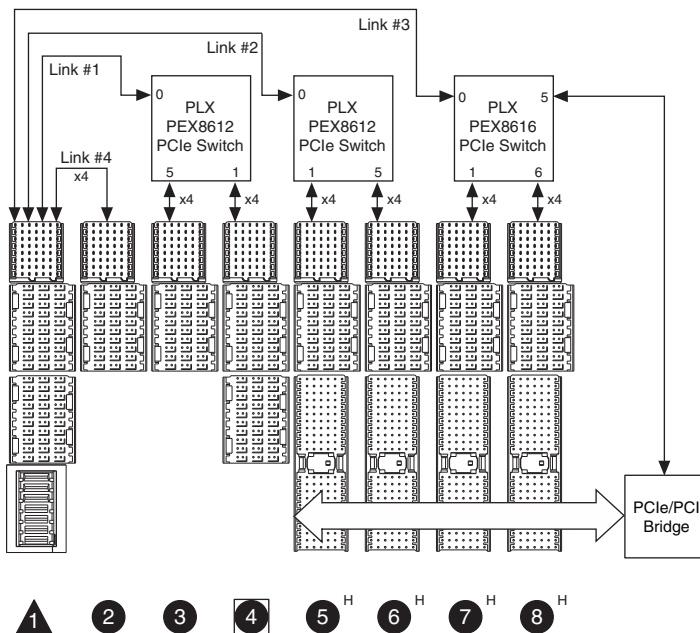

System Controller Slot

The system controller slot is Slot 1 of the chassis and is a 4-Link configuration system slot as defined by the CompactPCI Express and PXI Express specifications. It has three system controller expansion slots for system controller modules that are wider than one slot. These slots allow the system controller to expand to the left to prevent the system controller from using peripheral slots.

The backplane routes three of the system slot's x4 PCI Express (PCIe) links to a PCIe switch. The three PCIe switches have x4 PCIe links routed to each peripheral slot as well as a x1 link to a PCIe-to-PCI bridge providing a 32-bit/33 MHz PCI bus to the hybrid slots. Slot 2 directly connects to the remaining link of the system slot. Refer to Figure 1-3 for the connectivity of PCIe and PCI.

By default, the system controller will control the power supply with the PS_ON# signals. A logic low on this line will turn the power supply on.



Note The Inhibit Mode switch on the rear of the chassis must be in the **Default** position for the system controller to have control of the power supply. Refer to the [Inhibit Mode Switch](#) section of Chapter 2, *Installation and Configuration*, for details about the Inhibit Mode switch.

Hybrid Peripheral Slots

The chassis provides four hybrid peripheral slots as defined by the *PXI-5 PXI Express Hardware Specification*: slots 5 through 8. A hybrid peripheral slot can accept the following peripheral modules:

- A PXI Express Peripheral with x4 or x1 PCI Express link to the system slot
- A CompactPCI Express Type-2 Peripheral with x4 or x1 PCI Express link to the system slot
- A hybrid-compatible PXI Peripheral module that has been modified by replacing the J2 connector with an XJ4 connector installed in the upper eight rows of J2. Refer to the *PXI Express Specification* for details. The PXI Peripheral communicates through the backplane's 32-bit PCI bus.
- A CompactPCI 32-bit peripheral on the backplane's 32-bit PCI bus

The hybrid peripheral slots provide full PXI Express functionality and 32-bit PXI functionality except for PXI Local Bus. The hybrid peripheral slot only connects to PXI Local Bus 6 left and right.

PXI Express Peripheral Slots

There are two PXI Express peripheral slots: slot 2 and slot 3. PXI Express peripheral slots accept the following modules:

- A PXI Express Peripheral with x4 or x1 PCI Express link to the system slot
- A CompactPCI Express Type-2 Peripheral with x4 or x1 PCI Express link to the system slot

System Timing Slot

The System Timing Slot is slot 4. The system timing slot will accept the following peripheral modules:

- A PXI Express System Timing Module with x4 or x1 PCI Express link to the system slot.
- A PXI Express Peripheral with x4 or x1 PCI Express link to the system slot.
- A CompactPCI Express Type-2 Peripheral with x4 or x1 PCI Express link to the system slot.

The system timing slot has 3 dedicated differential pairs (PXIe_DSTAR) connected from the TP2 connector to the XP3 connector for each hybrid peripheral slot, as well as routed back to the XP3 connector of the system timing slot as shown in Figure 1-4. The PXIe_DSTAR pairs can be used for high-speed triggering, synchronization and clocking. Refer to the *PXI Express Specification* for details.

The system timing slot also has a single-ended (PXI Star) trigger connected to every slot. Refer to Figure 1-4 for details.

The system timing slot has a pin (PXI_CLK10_IN) through which a system timing module may source a 10 MHz clock to which the backplane will phase-lock. Refer to the *System Reference Clock* section for details.

The system timing slot has a pin (PXIe_SYNC_CTRL) through which a system timing module can control the PXIe_SYNC100 timing. Refer to the *PXI Express Specification* and the *PXIe_SYNC_CTRL* section of this chapter for details.

Figure 1-4. PXIe_DSTAR and PXI Star Connectivity Diagram

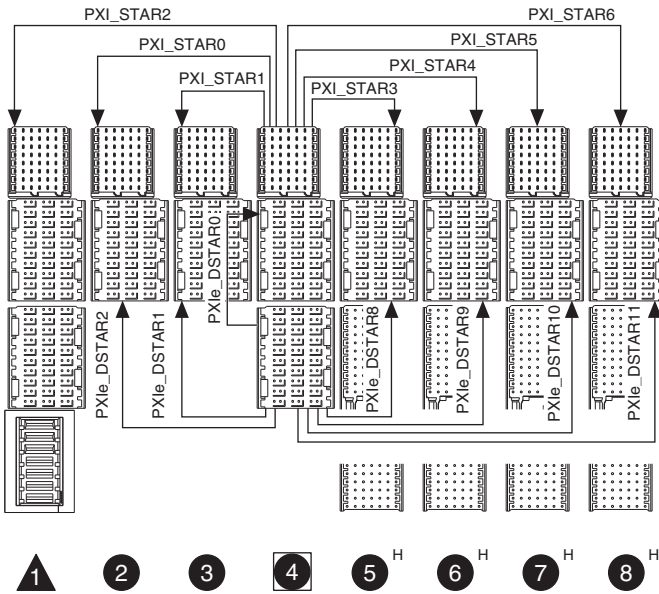

PXI Local Bus

The PXI backplane local bus is a daisy-chained bus that connects each peripheral slot with adjacent peripheral slots to the left and right.

The backplane routes PXI Local Bus 6 between adjacent PXI slots. The left Local Bus 6 from slot 1 is not routed anywhere. The right Local Bus 6 from slot 8 is also not routed anywhere.

Local bus signals may range from high-speed TTL signals to analog signals as high as 42 V.

Initialization software uses the configuration information specific to each adjacent peripheral module to evaluate local bus compatibility.

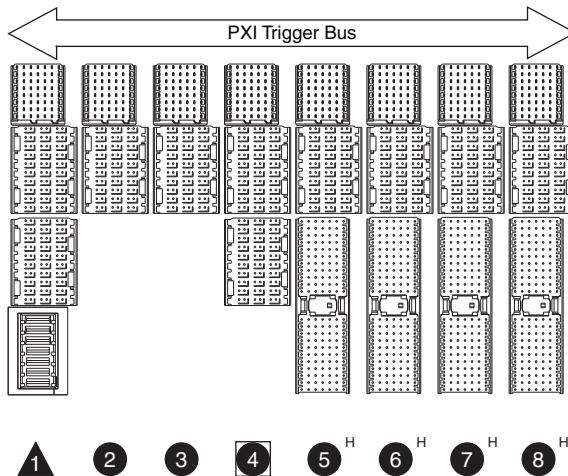
Figure 1-5. PXI Trigger Bus Connectivity Diagram

PXI Trigger Bus

All slots share eight trigger lines. You can use these trigger lines in a variety of ways. For example, you can use triggers to synchronize the operation of several different PXI peripheral modules. In other applications, one module can control carefully timed sequences of operations performed on other modules in the system. Modules can pass triggers to one another, allowing precisely timed responses to asynchronous external events the system is monitoring or controlling.

System Reference Clock

The NI PXIe-1082DC chassis supplies PXI_CLK10, PXIe_CLK100, and PXIe_SYNC100 to every peripheral slot with an independent driver for each signal.

An independent buffer (having a source impedance matched to the backplane and a skew of less than 500 ps between slots) drives PXI_CLK10 to each peripheral slot. You can use this common reference clock signal to synchronize multiple modules in a measurement or control system.

An independent buffer drives PXIe_CLK100 to each peripheral slot. These clocks are matched in skew to less than 100 ps. The differential pair must be terminated on the peripheral with LVPECL termination for the buffer to drive PXIe_CLK100 so that when there is no peripheral or a peripheral that does not connect to PXIe_CLK100, there is no clock being driven on the pair to that slot.

An independent buffer drives PXIe_SYNC100 to each peripheral slot. The differential pair must be terminated on the peripheral with LVPECL termination for the buffer to drive PXIe_SYNC100 so that when there is no peripheral or a peripheral that does not connect to PXIe_SYNC100, there is no clock being driven on the pair to that slot.

PXI_CLK10, PXIe_CLK100 and PXIe_SYNC100 have the default timing relationship described in Figure 1-6.

Figure 1-6. System Reference Clock Default Behavior

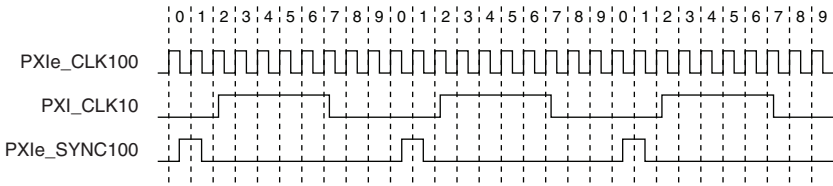

To synchronize the system to an external clock, you can drive PXI_CLK10 from an external source through the PXI_CLK10_IN pin on the System Timing Slot. Refer to Table B-7, *XP4 Connector Pinout for the System Timing Slot*, for the pinout. When a 10 MHz clock is detected on this pin, the backplane automatically phase-locks the PXI_CLK10, PXIe_CLK100, and PXIe_SYNC100 signals to this external clock and distributes these signals to the slots. Refer to Appendix A, *Specifications*, for the specification information for an external clock provided on the PXI_CLK10_IN pin of the system timing slot.

You also can drive a 10 MHz clock on the 10 MHz REF IN connector on the rear of the chassis. Refer to Figure 1-2 for the location of this connector. When a 10 MHz clock is detected on this connector, the backplane automatically phase-locks the PXI_CLK10, PXIe_CLK100, and PXIe_SYNC100 signals to this external clock and distributes these signals to the slots. Refer to Appendix A, *Specifications*, for the specification information for an external clock provided on the 10 MHz REF IN connector on the rear panel of the chassis.

If the 10 MHz clock is present on both the PXI_CLK10_IN pin of the System Timing Slot and the 10 MHz REF IN connector on the rear of the chassis, the signal on the System Timing Slot is selected. Refer to Table 1-1 which explains how the 10 MHz clocks are selected by the backplane.

Table 1-1. Backplane External Clock Input Truth Table

System Timing Slot PXI_CLK10_IN	Rear Chassis Panel 10 MHz REF IN	Backplane PXI_CLK10, PXIe_CLK100 and PXIe_SYNC100
No clock present	No clock present	Backplane generates its own clocks
No clock present	10 MHz clock present	PXI_CLK10, PXIe_CLK100 and PXIe_SYNC100 all phase-locked to Rear Chassis Panel—10 MHz REF IN

Table 1-1. Backplane External Clock Input Truth Table (Continued)

System Timing Slot PXI_CLK10_IN	Rear Chassis Panel 10 MHz REF IN	Backplane PXI_CLK10, PXIe_CLK100 and PXIe_SYNC100
10 MHz clock present	No clock present	PXI_CLK10, PXIe_CLK100 and PXIe_SYNC100 all phase-locked to System Timing Slot—PXI_CLK10_IN
10 MHz clock present	10 MHz clock present	PXI_CLK10, PXIe_CLK100 and PXIe_SYNC100 all phase-locked to System Timing Slot—PXI_CLK10_IN

A copy of the backplane's PXI_CLK10 is exported to the 10 MHz REF OUT connector on the rear of the chassis. Refer to Figure 1-2 for the location of this connector. This clock is driven by an independent buffer. Refer to Appendix A, *Specifications*, for the specification information for the 10 MHz REF OUT signal on the rear panel of the chassis.

PXIe_SYNC_CTRL

PXIe_SYNC100 is by default a 10 ns pulse synchronous to PXI_CLK10. The frequency of PXIe_SYNC100 is $10/n$ MHz, where n is a positive integer. The default for n is 1, giving PXIe_SYNC100 a 100 ns period. However, the backplane allows n to be programmed to other integers. For instance, setting $n = 3$ gives a PXIe_SYNC100 with a 300ns period while still maintaining its phase relationship to PXI_CLK10. The value for n may be set to any positive integer from 1 to 255.

The system timing slot has a control pin for PXIe_SYNC100 called PXIe_SYNC_CTRL for use when $n > 1$. Refer to Table B-6, *XP3 Connector Pinout for the System Timing Slot*, for system timing slot pinout. Refer to Appendix A, *Specifications*, for the PXIe_SYNC_CTRL input specifications.

By default, a high-level detected by the backplane on the PXIe_SYNC_CTRL pin causes a synchronous restart for the PXIe_SYNC100 signal. On the next PXI_CLK10 edge the PXIe_SYNC100 signal will restart. This will allow several chassis to have their PXIe_SYNC100 in phase with each other. Refer to Figure 1-7 for timing details with this method.

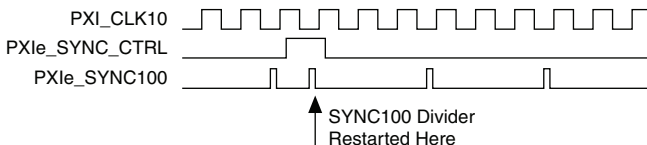
Figure 1-7. PXIe_SYNC100 at 3.33 MHz Using PXIe_SYNC_CTRL as Restart

Installation and Configuration

This chapter describes how to prepare and operate the NI PXIe-1082DC chassis.

Before connecting the chassis to a power source, read this chapter and the *Read Me First: Safety and Electromagnetic Compatibility* document included with your kit.

Safety Information



Caution Before undertaking any troubleshooting, maintenance, or exploratory procedure, carefully read the following caution notices.

This equipment contains voltage hazardous to human life and safety, and is capable of inflicting personal injury.

- **Chassis Grounding**—The chassis requires a connection from the premise wire safety ground to the chassis ground. The earth safety ground must be connected during use of this equipment to minimize shock hazards. Refer to the [Connecting Safety Ground](#) section for instructions on connecting safety ground.
- **Live Circuits**—Operating personnel and service personnel *must* not remove protective covers when operating or servicing the chassis. Adjustments and service to internal components must be undertaken by qualified service technicians. During service of this product, the mains connector to the premise wiring must be disconnected. Dangerous voltages may be present under certain conditions; use extreme caution.
- **Explosive Atmosphere**—Do *not* operate the chassis in conditions where flammable gases are present. Under such conditions, this equipment is unsafe and may ignite the gases or gas fumes.
- **Part Replacement**—Only service this equipment with parts that are exact replacements, both electrically and mechanically. Contact National Instruments for replacement part information. Installation of parts with those that are not direct replacements may cause harm to personnel operating the chassis. Furthermore, damage or fire may occur if replacement parts are unsuitable.
- **Modification**—Do *not* modify any part of the chassis from its original condition. Unsuitable modifications may result in safety hazards.

Chassis Cooling Considerations

The NI PXIe-1082DC chassis is designed to operate on a bench or in an instrument rack. The chassis must be oriented horizontally for benchtop use. Vertical orientation with the chassis handle up is not a supported configuration. Regardless of the configuration you must provide the cooling clearances as outlined in the following sections.

Providing Adequate Clearance

The primary cooling exhaust vent for the NI PXIe-1082DC is on the top of the chassis. The primary intake vent is on the rear of the chassis where the air is filtered as it enters the power supply shuttle. The secondary intake and exhaust vents are located along the sides of the chassis. Adequate clearance between the chassis and surrounding equipment or blockages must be maintained to ensure proper cooling of the chassis power supply as well as the modules plugged into the chassis. These clearances are outlined in Figure 2-1. The vent locations for the NI PXIe-1082DC chassis are shown in Figure 2-2. Failure to provide these clearances may result in thermal-related failures in the chassis or modules.

Figure 2-1. NI PXIe-1082DC Cooling Clearances

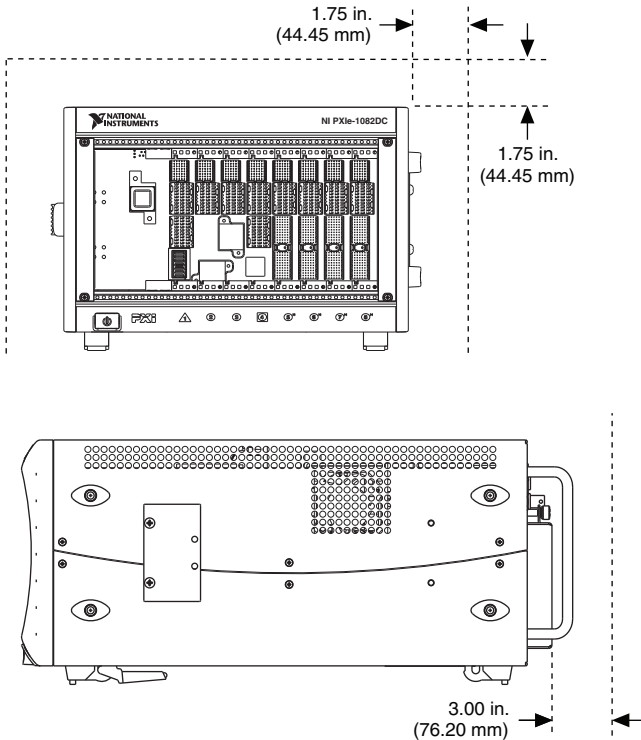
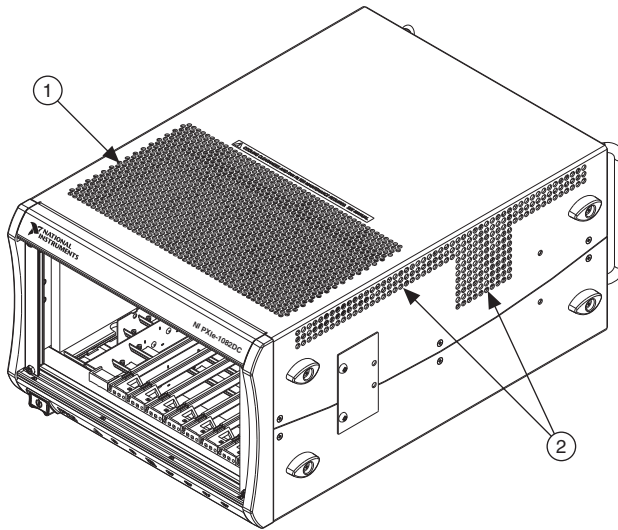

Figure 2-2. NI PXIe-1082DC Vents

1 Primary Air Exhaust Vent

2 Secondary Air Intake/Exhaust Vents

Chassis Ambient Temperature Definition

The chassis fan control system uses intake air temperature as the input for controlling fan speeds when in Auto Fan Speed mode. Because of this, the chassis ambient temperature is defined as the temperature that exists just outside of the fan intake vents on the rear of the chassis. Note that this temperature may be higher than ambient room temperature depending on the surrounding equipment and/or blockages present. It is the user's responsibility to ensure that this ambient temperature does not exceed the rated ambient temperature as stated in Appendix A, [Specifications](#). If the temperature exceeds the stated spec the power switch LED will blink green, as discussed in the [Power Inhibit Switch LED Indicator](#) section of this chapter.

Setting Fan Speed

The fan-speed selector switch is on the rear panel of the NI PXIe-1082DC chassis. Refer to Figure 1-2, [Rear View of the NI PXIe-1082DC Chassis](#), to locate the fan-speed selector switch. Select **High** for maximum cooling performance or **Auto** for improved acoustic performance. When set to **Auto**, the fan speed is determined by chassis intake air temperature.

Rack Mounting

Rack mount applications require the optional rack mount kits available from National Instruments. Refer to the instructions supplied with the rack mount kits to install your NI PXIe-1082DC chassis in an instrument rack. Refer to Figure A-3, [NI Chassis Rack Mount Kit Components](#).



Note You may want to remove the feet from the NI PXIe-1082DC chassis when rack mounting. To do so, remove the screws holding the feet in place.

Connecting Safety Ground

You must connect the premise safety ground to the chassis grounding screw located on the rear panel. Refer to Figure 1-2, *Rear View of the NI PXIe-1082DC Chassis*, to locate the chassis grounding screw. To connect the safety ground, complete the following steps:

1. Connect a 16 AWG (1.3 mm) wire to the chassis grounding screw using a grounding lug. The wire must have green insulation with a yellow stripe or must be noninsulated (bare).
2. Attach the opposite end of the wire to permanent earth ground using toothed washers or a toothed lug.

Connecting to Power Source



Caution Do *not* install modules prior to performing the following power-on test. To completely remove power, you *must* disconnect the DC power cable.

Attach input power through the rear DC inlet using the appropriate DC power cable supplied. Refer to Figure 1-2, *Rear View of the NI PXIe-1082DC Chassis*, to locate the DC inlet.

The Inhibit Mode switch allows you to power on the chassis or place it in standby mode. Set the Inhibit Mode switch on the back of the chassis to the **Manual** position. Observe that all fans become operational and the power switch LED is a steady green. Switching the Inhibit Mode switch to the **Default** position allows the system controller to control the power supply.

Installing a PXI Express System Controller

This section contains general installation instructions for installing a PXI Express system controller in a NI PXIe-1082DC chassis. Refer to your PXI Express system controller user manual for specific instructions and warnings. To install a system controller, complete the following steps:

1. Inspect the slot 1 pins on the chassis backplane for any bending or damage prior to installation.
2. Connect the chassis ground screw to the safety ground before installing the system controller.
3. Connect the DC power source to the PXI Express chassis before installing the system controller.
4. Install the system controller into the system controller slot (slot 1, indicated by the red card guides) by first placing the system controller PCB into the front of the card guides (top and bottom). Slide the system controller to the rear of the chassis, making sure that the injector/ejector handle is pushed down as shown in Figure 2-3.

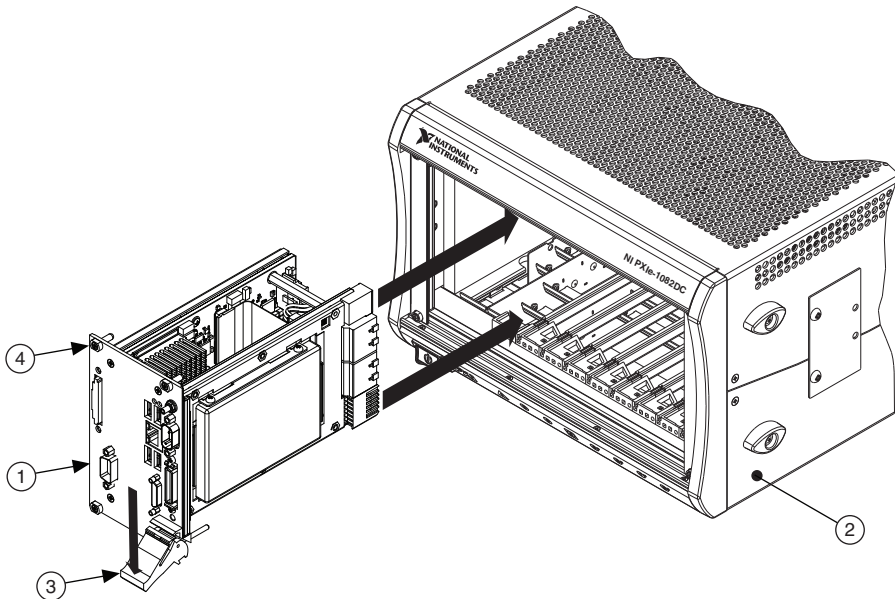
Figure 2-3. Installing a PXIe System Controller

1	NI PXI Express System Controller	3	Injector/Ejector Handle
2	NI PXIe-1082DC Chassis	4	System Controller Front Panel Mounting Screws (4x)

- When you begin to feel resistance, push up on the injector/ejector handle to seat the system controller fully into the chassis frame. Secure the system controller front panel to the chassis using the system controller front-panel mounting screws.
- Connect the keyboard, mouse, and monitor to the appropriate connectors. Connect devices to ports as required by your system configuration.
- Power on the chassis. Verify that the system controller boots. If the system controller does not boot, refer to your system controller user manual.

Figure 2-4 shows a PXI Express system controller installed in the system controller slot of a NI PXIe-1082DC chassis. You can place CompactPCI, CompactPCI Express, PXI, or PXI Express modules in other slots depending on the slot type.

Figure 2-4. PXI Express System Controller Installed in a NI PXIe-1082DC Chassis

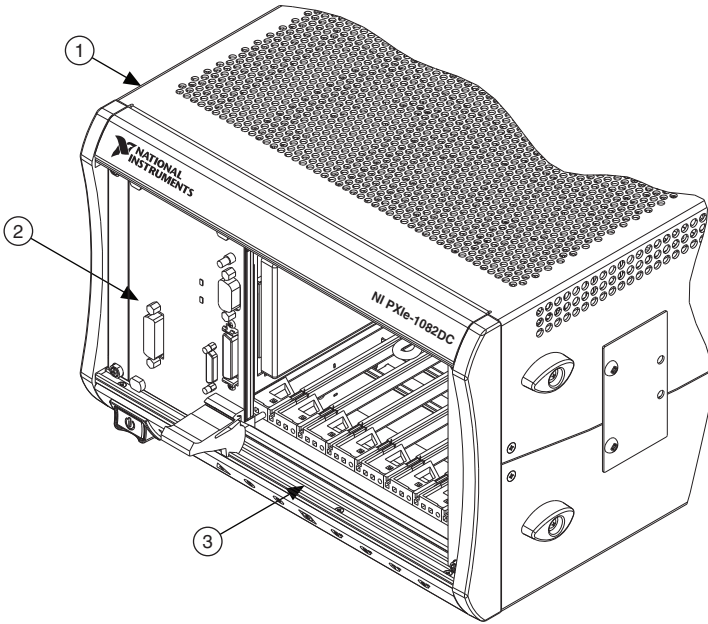

1 NI PXIe-1082DC Chassis 2 NI PXIe System Controller 3 Injector/Ejector Rail

Installing Peripheral Modules



Caution The NI PXIe-1082DC chassis has been designed to accept a variety of peripheral module types in different slots. To prevent damage to the chassis, ensure that the peripheral module is being installed into a slot designed to accept it. Refer to Chapter 1, *Getting Started*, for a description of the various slot types.

This section contains general installation instructions for installing a peripheral module in a NI PXIe-1082DC chassis. Refer to your peripheral module user manual for specific instructions and warnings. To install a module, complete the following steps:

1. Inspect the slot pins on the chassis backplane for any bending or damage prior to installation.
2. Connect the chassis ground screw to the safety ground before installing the module.
3. Connect the DC power source to the PXI Express chassis before installing the module.

4. Ensure that the chassis is powered off.
5. Install a module into a chassis slot by first placing the module card PCB into the front of the card guides (top and bottom), as shown in Figure 2-5. Slide the module to the rear of the chassis, making sure that the injector/ejector handle is pushed down as shown in Figure 2-5.
6. When you begin to feel resistance, push up on the injector/ejector handle to fully seat the module into the chassis frame. Secure the module front panel to the chassis using the module front-panel mounting screws.

Figure 2-5. Installing PXI, PXI Express, or CompactPCI Peripheral Modules

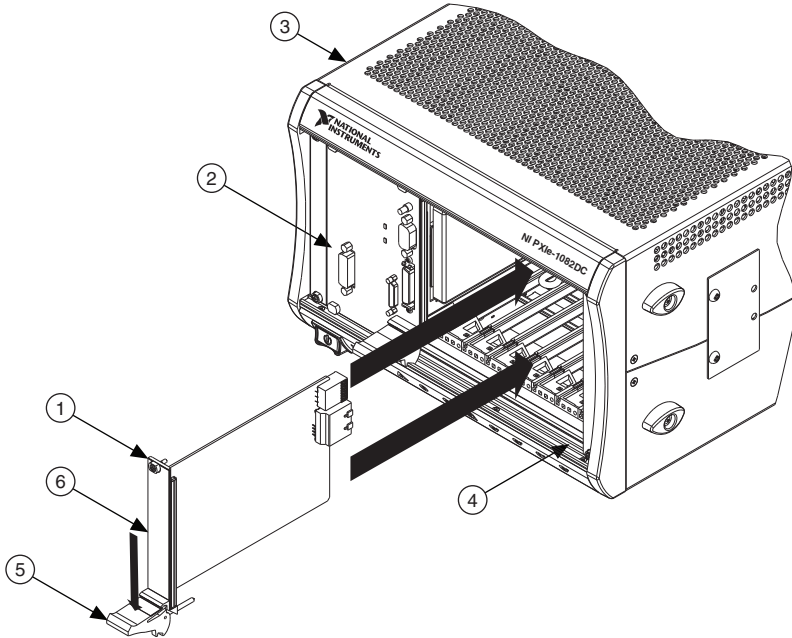

- | | | | |
|---|--|---|-------------------------|
| 1 | Peripheral Module Front Panel Mounting Screws (2x) | 4 | Injector/Ejector Rail |
| 2 | NI PXI Express System Controller | 5 | Injector/Ejector Handle |
| 3 | NI PXIe-1082DC Chassis | 6 | PXI Peripheral Module |

Power Inhibit Switch LED Indicator

The chassis power inhibit switch has an integrated LED. This LED indicates one of four different conditions:

- If the inhibit switch LED is steady green (not flashing), the chassis is powered on and operating normally.
- If the inhibit switch LED is flashing green, the air-intake temperature has exceeded the chassis operating range.
- If the inhibit switch LED is flashing red, the power supply outputs are not within voltage regulation requirements.
- If the inhibit switch LED is steady red, the system fans or power supply fan has failed. The remaining fans will automatically be driven high.



Note If both system fans or the power supply fan fails the chassis will shut down automatically, preventing the chassis and modules from damage due to overheating.

Remote Voltage Monitoring and Control

The NI PXIe-1082DC chassis supports remote voltage monitoring and inhibiting through a female 9-pin D-SUB (DB-9) connector located on the rear panel. Table 2-1 shows the pinout of the 9-pin D-SUB (DB-9) connector.

Table 2-1. Remote Inhibit and Voltage Monitoring Connector Pinout

DB-9 Pin	Signal
1	Logic Ground
2	+5 VDC
3	Reserved
4	+3.3 VDC
5	Inhibit (Active Low)
6	+12 VDC
7	Reserved

Table 2-1. Remote Inhibit and Voltage Monitoring Connector Pinout (Continued)

DB-9 Pin	Signal
8	-12 VDC
9	Logic Ground

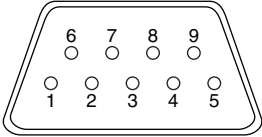

Caution When connecting digital voltmeter probes to the rear 9-pin D-SUB (DB-9) connector, be careful not to short the probe leads together. Doing so could damage the power supply.

You can use a digital voltmeter to ensure all voltage levels in the NI PXIe-1082DC chassis are within the allowable limits. Referring to Table 2-2, connect one lead of the voltmeter to a supply pin on the remote voltage monitoring connector (9-pin D-SUB) on the rear panel. Refer to Table 2-1 for a pinout diagram of the remote voltage monitoring connector. Connect the reference lead of the voltmeter to one of the ground pins. Compare each voltage reading to the values listed in Table 2-2.



Note Use the rear-panel 9-pin D-SUB connector to check voltages only. Do not use the connector to supply power to external devices.

Table 2-2. Power Supply Voltages at Voltage Monitoring Connector (DB-9)

Pin	Supply	Acceptable Voltage Range
2	+5 V	4.75 to 5.25 V
4	+3.3 V	3.135 to 3.465 V
6	+12 V	11.4 to 12.6 V
8	-12 V	-12.6 to -11.4 V
1, 9	Logic Ground	0 V

If the voltages fall within the specified ranges, the chassis complies with the CompactPCI voltage-limit specifications.

Inhibit Mode Switch

On the rear panel of the chassis there is an Inhibit Mode switch. Refer to Figure 1-2, *Rear View of the NI PXIe-1082DC Chassis*, for the location. The Inhibit Mode switch is recessed to prevent it from accidentally being switched.

The Inhibit Mode switch should be in the **Default** position when normal power inhibit switch functionality is desired. If the user needs to power on a chassis without a system controller installed the switch should be in the **Manual** position.

When the Inhibit Mode switch is set to the **Manual** position, the power supplies are enabled, and you can use the Inhibit signal (active low) on pin 5 of the Remote Inhibit and Voltage Monitoring connector to power off the chassis. To remotely power off the chassis, connect the Inhibit pin (pin 5) to a Logic Ground pin (pin 1 or 9). As long as this connection exists, the chassis will remain off (standby); when you remove this connection, the chassis turns on.



Note For the Remote Inhibit signal to control the On/Off (standby) state of the chassis, the Inhibit Mode switch must be in the **Manual** position.

PXI_CLK10 Rear Connectors

There are two BNC connectors on the rear of the NI PXIe-1082DC chassis for PXI_CLK10. The connectors are labeled IN and OUT. You can use them for supplying the backplane with PXI_CLK10 or routing the backplane's PXI_CLK10 to another chassis. Refer to the *System Reference Clock* section of Chapter 1, *Getting Started*, for details about these signals.

PXI Express System Configuration with MAX

The PXI Platform Services software included with your chassis automatically identifies your PXI Express system components to generate a `pxiesys.ini` file. You can configure your entire PXI system and identify PXI-1 chassis through Measurement & Automation Explorer (MAX), included with your system controller. MAX creates the `pxiesys.ini` and `pxisys.ini` file, which define your PXI system parameters. MAX also provides an interface to route and reserve triggers so dynamic routing, through drivers such as DAQmx, avoids double-driving and potentially damaging trigger lines. For more information about routing and reserving PXI triggers, refer to KnowledgeBase 3TJDOND8 at ni.com/support.

The configuration steps for single or multiple-chassis systems are the same.

Figure 2-6. Multichassis Configuration in MAX

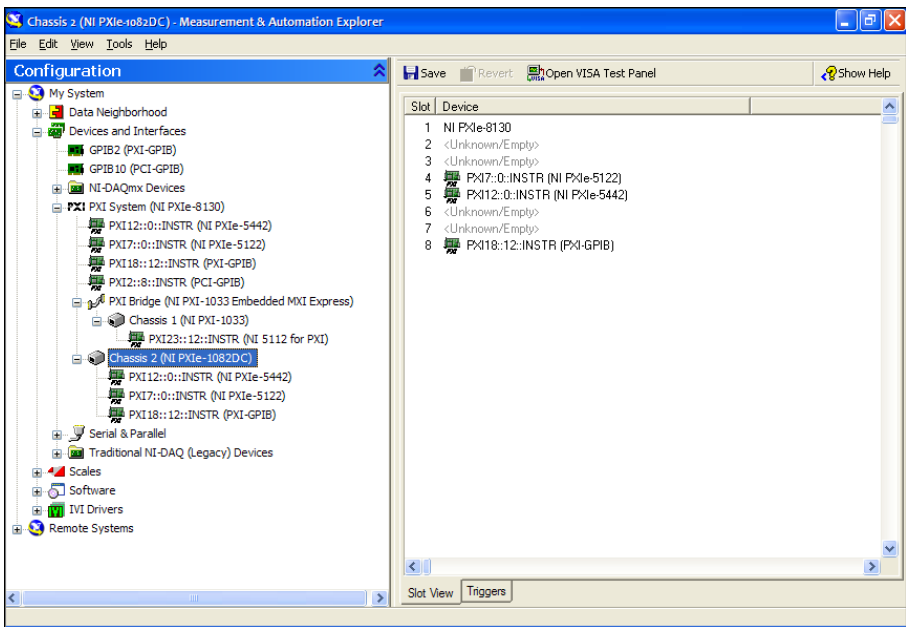

PXI-1 System Configuration

1. Launch MAX.
2. In the **Configuration** tree, click the **Devices and Interfaces** branch to expand it.
3. If the PXI system controller has not yet been configured, it is labeled **PXI System (Unidentified)**. Right-click this entry to display the pop-up menu, then select the appropriate system controller model from the **Identify As** submenu.
4. Click the PXI system controller. The chassis (or multiple chassis, in a multichassis configuration) is listed below it. Identify each chassis by right-clicking its entry, then selecting the appropriate chassis model through the **Identify As** submenu. Further expanding the **PXI System** branch shows all devices in the system that can be recognized by NI-VISA. When your system controller and all your chassis are identified, the required `pxisys.ini` file is complete.

The PXI specification allows for many combinations of PXI chassis and system modules. To assist system integrators, the manufacturers of PXI chassis and system modules must document the capabilities of their products. PXI Express devices must provide a driver and `.ini` file for identification. These files are provided as part of the PXI Platform Services software included with your system controller. The minimum documentation requirements for PXI-1 are contained in `.ini` files, which consist of ASCII text. System integrators, configuration utilities, and device drivers can use these `.ini` files.

The capability documentation for a PXI-1 chassis is contained in a `chassis.ini` file provided by the chassis manufacturer. The information in this file is combined with information about the system controller to create a single PXI-1 system initialization file called `pxisys.ini` (PXI System Initialization). The NI system controller uses MAX to generate the `pxisys.ini` file from the `chassis.ini` file.

Device drivers and other utility software read the `pxiesys.ini` and `pxisys.ini` file to obtain system information. For detailed information about initialization files, refer to the PXI specification at www.pxisa.org.

Using System Configuration and Initialization Files

The PXI Express specification allows many combinations of PXI Express chassis and system modules. To assist system integrators, the manufacturers of PXI Express chassis and system modules must document the capabilities of their products. The minimum documentation requirements are contained in `.ini` files, which consist of ASCII text. System integrators, configuration utilities, and device drivers can use these `.ini` files.

The capability documentation for the NI PXIe-1082DC chassis is contained in the `chassis.ini` file on the software media that comes with the chassis. The information in this file is combined with information about the system controller to create a single system initialization file called `pxisys.ini` (PXI System Initialization). The system controller manufacturer either provides a `pxisys.ini` file for the particular chassis model that contains the system controller or provides a utility that can read an arbitrary `chassis.ini` file and generate the corresponding `pxisys.ini` file. System controllers from NI provide the `pxisys.ini` file for the NI PXIe-1082DC chassis, so you should not need to use the `chassis.ini` file. Refer to the documentation provided with the system controller or to ni.com/support for more information on `pxisys.ini` and `chassis.ini` files.

Device drivers and other utility software read the `pxisys.ini` file to obtain system information. The device drivers should have no need to directly read the `chassis.ini` file. For detailed information regarding initialization files, refer to the PXI Express specification at www.pxisa.org.

Maintenance

This chapter describes basic maintenance procedures you can perform on the NI PXIe-1082DC chassis.



Caution Disconnect the power cable prior to servicing a NI PXIe-1082DC chassis.

Service Interval

Clean dust from the chassis exterior (and interior) as needed, based on the operating environment. Periodic cleaning increases reliability and cooling performance.

Preparation

The information in this section is designed for use by qualified service personnel. Read the *Read Me First: Safety and Electromagnetic Compatibility* document included with your kit before attempting any procedures in this chapter.



Caution Many components within the chassis are susceptible to static discharge damage. Service the chassis only in a static-free environment. Observe standard handling precautions for static-sensitive devices while servicing the chassis. Always wear a grounded wrist strap or equivalent while servicing the chassis.

Cleaning

Cleaning procedures consist of exterior and interior cleaning of the chassis and cleaning the fan filters. Refer to your module user documentation for information on cleaning the individual CompactPCI or PXI Express modules.



Caution *Always* disconnect the DC power cable before cleaning or servicing the chassis.

Interior Cleaning

Use a dry, low-velocity stream of air to clean the interior of the chassis. Use a soft-bristle brush for cleaning around components.

Exterior Cleaning

Clean the exterior surfaces of the chassis with a dry lint-free cloth or a soft-bristle brush. If any dirt remains, wipe with a cloth moistened in a mild soap solution. Remove any soap residue by wiping with a cloth moistened with clear water. Do not use abrasive compounds on any part of the chassis.



Caution Avoid getting moisture inside the chassis during exterior cleaning, especially through the top vents. Use just enough moisture to dampen the cloth.



Caution Do *not* wash the front- or rear-panel connectors or switches. Cover these components while cleaning the chassis.



Caution Do *not* use harsh chemical cleaning agents; they may damage the chassis. Avoid chemicals that contain benzene, toluene, xylene, acetone, or similar solvents.

Resetting the DC Mains Circuit Breaker

If the NI PXIe-1082DC chassis is connected to a DC source and encounters an over-current condition, the circuit breaker on the rear panel will trip to prevent damage to the chassis. Complete the following steps to reset the circuit breaker.

1. Turn off the chassis.
2. Disconnect the DC power cable.
3. Reset the circuit breaker switch.
4. Reconnect the DC power cable.
5. Turn on the chassis.

If the circuit breaker trips again, complete the following steps:

1. Turn off the chassis.
2. Disconnect the DC power cable.
3. Remove all modules from the chassis.
4. Complete the procedure described in the [Connecting to Power Source](#) section of Chapter 2, [Installation and Configuration](#). If the power switch LED is not a steady green, contact National Instruments.
5. Verify that the NI PXIe-1082DC chassis can meet the power requirements of your CompactPCI or PXI Express modules. Overloading the chassis can cause the breaker to trip. Refer to Appendix A, [Specifications](#).
6. The over-current condition that caused the circuit breaker to trip may be due to a faulty CompactPCI or PXI Express module. Refer to the documentation supplied with the modules for troubleshooting information.

Replacing the Modular Power Supply

This section describes how to remove, configure, and install the DC power supply shuttle in the NI PXIe-1082DC chassis. For more information, refer to the *NI PXIe-1082DC Power Supply Shuttle User Guide* included with your replacement power supply shuttle module.



Caution Disconnect the power cable prior to replacing the power supply.



Caution Do not attempt to use a power supply shuttle from another chassis such as the NI PXI-1042 or NI PXIe-1062Q. Doing so may damage your chassis and the power supply shuttle.

Before connecting the power supply shuttle to a power source, read this section and the *Read Me First: Safety and Electromagnetic Compatibility* document included with the kit.

Removal

The NI PXIe-1082DC power supply is a replacement part for the NI PXIe-1082DC chassis. Before attempting to replace the power supply shuttle, verify that there is adequate clearance behind the chassis. Disconnect the power cable from the power supply shuttle on the back of the chassis. Identify the eight mounting screws for the NI PXIe-1082DC that attach the power supply shuttle to the chassis. Refer to Figure 1-2, *Rear View of the NI PXIe-1082DC Chassis*, for the screw locations. Using a Phillips screwdriver, remove the screws. Pull on the two rear handles of the power supply shuttle to remove it from the back of the chassis.

Installation

Ensure that there is no visible damage to the new power supply shuttle. Verify that the housing and connector on the new power supply shuttle have no foreign material inside. Remove the protective cap on the PXI_CLK10 connector. Install the new power supply shuttle into the opening on the rear of the chassis. Replace and tighten the eight screws with a Phillips screwdriver.

Configuration

The fan-speed selector switch is on the rear panel of the power supply shuttle. Refer to Figure 1-2, *Rear View of the NI PXIe-1082DC Chassis*, to locate the fan-speed selector. Select **High** for maximum cooling performance (recommended) or **Auto** for quieter operation. Set the Inhibit Mode switch to the **Default** position.

Connecting to Power Source

Refer to the *Connecting to Power Source* section of Chapter 2, *Installation and Configuration*.

Specifications

This appendix contains specifications for the NI PXIe-1082DC chassis.



Caution Specifications are subject to change without notice.



Caution Overloading the circuits may damage supply wiring. Do not exceed the ratings on the equipment nameplate when connecting equipment to the supply circuit.

Electrical

DC Input

Input voltage range	11 to 32 VDC
Input current rating	45 to 15 A
Over-current protection	50 A circuit breaker
Line regulation	
3.3 V	< ± 0.2%
5 V	< ± 0.1%
±12 V	< ± 0.1%
Efficiency	65% typical
Power disconnect	The DC power cable provides main power disconnect. Do not position the equipment so that it is difficult to disconnect the power cord. The front panel power switch causes the internal chassis power supply to provide DC power to the CompactPCI/PXI Express backplane. You also can use the rear-panel D-SUB 9-pin connector and power mode switch to control the internal chassis power supply.



Caution Use the DC power cable provided with DC power supplies for VDC input.



Caution Using the NI PXIe-1082DC in a manner not described in this document may impair the protection the NI PXIe-1082DC provides.

DC Output

DC current capacity (I_{MP})

Voltage	Maximum Current
+3.3 V	32 A
+5 V	19 A
+12 V	32 A
-12 V	1.5 A
5 V _{AUX}	2.0 A



Notes Maximum total usable power is 315 W.

The maximum power dissipated in the system slot should not exceed 140 W.

The maximum power dissipated in a peripheral slot should not exceed 38.25 W.

Backplane pin current capacity

Slot	+5 V	V (I/O)	+3.3 V	+12 V	-12 V	5 V _{AUX}
System Controller Slot	15 A	—	15 A	30 A	—	1 A
System Timing Slot	—	—	6 A	4 A	—	1 A
Hybrid Peripheral Slot with PXI-1 Peripheral	6 A	5 A	6 A	1 A	1 A	—
Hybrid Peripheral Slot with PXI-5 Peripheral	—	—	6 A	4 A	—	1 A

Load regulation

Voltage	Load Regulation
+3.3 V	<5%
+12 V	<5%
+5 V	<5%
-12 V	<5%

Maximum ripple and noise (20 MHz bandwidth)

Voltage	Maximum Ripple and Noise
+3.3 V	50 mV _{pp}
+12 V	120 mV _{pp}
+5 V	50 mV _{pp}
-12 V	50 mV _{pp}

- Over-current protection All outputs protected from short circuit and overload (some faults require a power cycle for recovery)
- Over-voltage protection
 3.3 V and 5 V Clamped at 20 to 30% above nominal output voltage
- Power supply shuttle MTTR..... Replacement in under 5 minutes

Chassis Cooling

- Module cooling system..... Forced air circulation (positive pressurization) through two 110 cfm fans with High/Auto speed selector
- Slot airflow direction Bottom of module to top of module
- Module cooling intake Bottom rear of chassis
- Module cooling exhaust..... Along both sides and top of chassis
- Power supply cooling system Forced air circulation through integrated fan
- Power supply cooling intake..... Right side of chassis
- Power supply cooling exhaust Left side of chassis

Environmental

- Maximum altitude..... 4,600 m (570 mbar) (at 25 °C ambient)
- Measurement Category..... I
- Pollution Degree 2
- For indoor use only.



Note Measurement Categories CAT I and CAT O (Other) are equivalent. The input circuits are not intended for direct connection to the MAINS building installations of Categories CAT II, CAT III, or CAT IV.

Operating Environment

Ambient temperature range	0 to 55 °C (Tested in accordance with IEC 60068-2-1 and IEC 60068-2-2. Meets MIL-PRF-28800F Class 3 low temperature limit and MIL-PRF-28800F Class 2 high temperature limit.)
Relative humidity range.....	10 to 90%, noncondensing (Tested in accordance with IEC 60068-2-56.)

Storage Environment

Ambient temperature range	-40 to 71 °C (Tested in accordance with IEC 60068-2-1 and IEC 60068-2-2. Meets MIL-PRF-28800F Class 3 limits.)
Relative humidity range.....	5 to 95%, noncondensing (Tested in accordance with IEC 60068-2-56.)

Shock and Vibration

Operational shock	30 g peak, half-sine, 11 ms pulse (Tested in accordance with IEC 60068-2-27. Meets MIL-PRF-28800F Class 2 limits.)
Random Vibration	
Operating	5 to 500 Hz, 0.3 g _{rms}
Non-operating	5 to 500 Hz, 2.4 g _{rms} (Tested in accordance with IEC 60068-2-64. Nonoperating test profile exceeds the requirements of MIL-PRF-28800F, Class 3.)

Acoustic Emissions

(Tested in accordance with ISO 7779. Meets MIL-PRF-28800F requirements.)

Sound Pressure Level (at Operator Position)

Auto fan (up to ~30 °C ambient)	48.7 dBA
High fan	61.6 dBA

Sound Power

Auto fan (up to ~30 °C ambient)	57.7 dBA
High fan	72.5 dBA



Note Specifications are subject to change without notice.

Safety

This product is designed to meet the requirements of the following standards of safety for electrical equipment for measurement, control, and laboratory use:

- IEC 61010-1, EN 61010-1
- UL 61010-1, CSA 61010-1



Note For UL and other safety certifications, refer to the product label or the [Online Product Certification](#) section.

Electromagnetic Compatibility

This product is designed to meet the requirements of the following standards of EMC for electrical equipment for measurement, control, and laboratory use:

- EN 61326 (IEC 61326): Class A emissions; Basic immunity
- EN 55011 (CISPR 11): Group 1, Class A emissions
- AS/NZS CISPR 11: Group 1, Class A emissions
- FCC 47 CFR Part 15B: Class A emissions
- ICES-001: Class A emissions



Note For the standards applied to assess the EMC of this product, refer to the [Online Product Certification](#) section.



Note For EMC compliance, operate this device with shielded cabling.

CE Compliance

This product meets the essential requirements of applicable European Directives as follows:

- 2006/95/EC; Low-Voltage Directive (safety)
- 2004/108/EC; Electromagnetic Compatibility Directive (EMC)

Online Product Certification

Refer to the product Declaration of Conformity (DoC) for additional regulatory compliance information. To obtain product certifications and the DoC for this product, visit ni.com/certification, search by model number or product line, and click the appropriate link in the Certification column.

Environmental Management

NI is committed to designing and manufacturing products in an environmentally responsible manner. NI recognizes that eliminating certain hazardous substances from our products is beneficial to the environment and to NI customers.

For additional environmental information, refer to the *Minimize Our Environmental Impact* web page at ni.com/environment. This page contains the environmental regulations and directives with which NI complies, as well as other environmental information not included in this document.

Waste Electrical and Electronic Equipment (WEEE)



EU Customers At the end of their life cycle, all products *must* be sent to a WEEE recycling center. For more information about WEEE recycling centers and National Instruments WEEE initiatives, visit ni.com/environment/weee.htm.

电子信息产品污染控制管理办法（中国 RoHS）



中国客户 National Instruments 符合中国电子信息产品中限制使用某些有害物质指令 (RoHS)。关于 National Instruments 中国 RoHS 合规性信息，请登录 ni.com/environment/rohs_china。(For information about China RoHS compliance, go to ni.com/environment/rohs_china.)

Backplane

Size.....	3U-sized; one system slot (with three system expansion slots) and seven peripheral slots. Compliant with IEEE 1101.10 mechanical packaging. PXI Express Specification compliant. Accepts both PXI Express and CompactPCI (PICMG 2.0 R 3.0) 3U modules.
Backplane bare-board material	UL 94 V-0 Recognized
Backplane connectors	Conforms to IEC 917 and IEC 1076-4-101, and are UL 94 V-0 rated

System Synchronization Clocks (PXI_CLK10, PXIe_CLK100, PXIe_SYNC100)

10 MHz System Reference Clock: PXI_CLK10

Maximum slot-to-slot skew	500 ps
Accuracy	±25 ppm max (guaranteed over the operating temperature range)
Maximum jitter	5 ps RMS phase-jitter (10 Hz to 1 MHz range)

Duty-factor.....	45%-55%
Unloaded signal swing.....	3.3 V \pm 0.3 V



Note For other specifications refer to the *PXI-1 Hardware Specification*.

100 MHz System Reference Clock: PXIe_CLK100 and PXIe-SYNC100

Maximum slot-to-slot skew	100 ps
Accuracy.....	\pm 25 ppm max (guaranteed over the operating temperature range)
Maximum jitter	3 ps RMS phase-jitter (10 Hz to 12 kHz range) 2 ps RMS phase-jitter (12 kHz to 20 MHz range)
Duty-factor for PXIe_CLK100.....	45%-55%
Absolute differential voltage (When terminated with a 50 Ω load to 1.30 V or Thévenin equivalent).....	400 to 1000 mV



Note For other specifications refer to the *PXI-5 PXI Express Hardware Specification*.

External 10 MHz Reference Out (BNC on rear panel of chassis)

Accuracy.....	\pm 25 ppm max (guaranteed over the operating temperature range)
Maximum jitter	5 ps RMS phase-jitter (10 Hz-1 MHz range)
Output amplitude	1 V _{pp} \pm 20% square-wave into 50 Ω 2 V _{pp} unloaded
Output impedance.....	50 Ω \pm 5 Ω

External Clock Source

Frequency	10 MHz \pm 100 PPM
Input amplitude	
Rear panel BNC.....	200 mV _{pp} to 5 V _{pp} square-wave or sine-wave
System timing slot	
PXI_CLK10_IN.....	5 V or 3.3 V TTL signal
Rear panel BNC input impedance	50 Ω \pm 5 Ω
Maximum jitter introduced by backplane.....	1 ps RMS phase-jitter (10 Hz-1 MHz range)

PXIe_SYNC_CTRL

V _{IH}	2.0-5.5 V
V _{IL}	0-0.8 V

PXI Star Trigger

Maximum slot-to-slot skew	250 ps
Backplane characteristic impedance	65 Ω ±10%



Notes For PXI slot to PXI Star mapping refer to the *System Timing Slot* section of Chapter 1, *Getting Started*.

For other specifications refer to the *PXI-1 Hardware Specification*.

PXI Differential Star Triggers (PXIe-DSTARA, PXIe-DSTARB, PXIe-DSTARC)

Maximum slot-to-slot skew	150 ps
Maximum differential skew	25 ps
Backplane differential impedance.....	100 Ω ±10%



Notes For PXIe slot to PXI_DSTAR mapping refer to the *System Timing Slot* section of Chapter 1, *Getting Started*.

For other specifications, the NI PXIe-1082DC complies with the *PXI-5 PXI Express Hardware Specification*.

Mechanical

Overall dimensions

Standard chassis

Height.....	6.97 in. (177.1 mm)
Width.....	10.68 in. (271.4 mm)
Depth.....	15.61 in. (396.5 mm)



Note 0.57 in. (14.5 mm) is added to height when feet are installed. When tilted with front feet extended on table top, height is increased approximately 2.08 in. (52.8 mm) in front and 0.583 in. (14.8 mm) in rear.

Weight.....	19.4 lb (8.8 kg)
Chassis materials.....	Sheet Aluminum (5052-H32, 3003-H14, and 6061-T6), Extruded Aluminum (6060-T6), and Cold Rolled Steel, PC-ABS, Santoprene, Nylon

Finish Conductive Clear Iridite on Aluminum Clear
 Chromate Zinc Plating on Cold Rolled Steel
 Polyurethane Enamel

Figures A-1 and A-2 show the NI PXIe-1082DC chassis dimensions. The holes shown are for the installation of the optional rack mount kits. You can install those kits on the front or rear of the chassis, depending on which end of the chassis you want to face toward the front of the instrument cabinet. Notice that the front and rear chassis mounting holes (size M4) are symmetrical.

Figure A-1. NI PXIe-1082DC Chassis Dimensions (Front and Side)

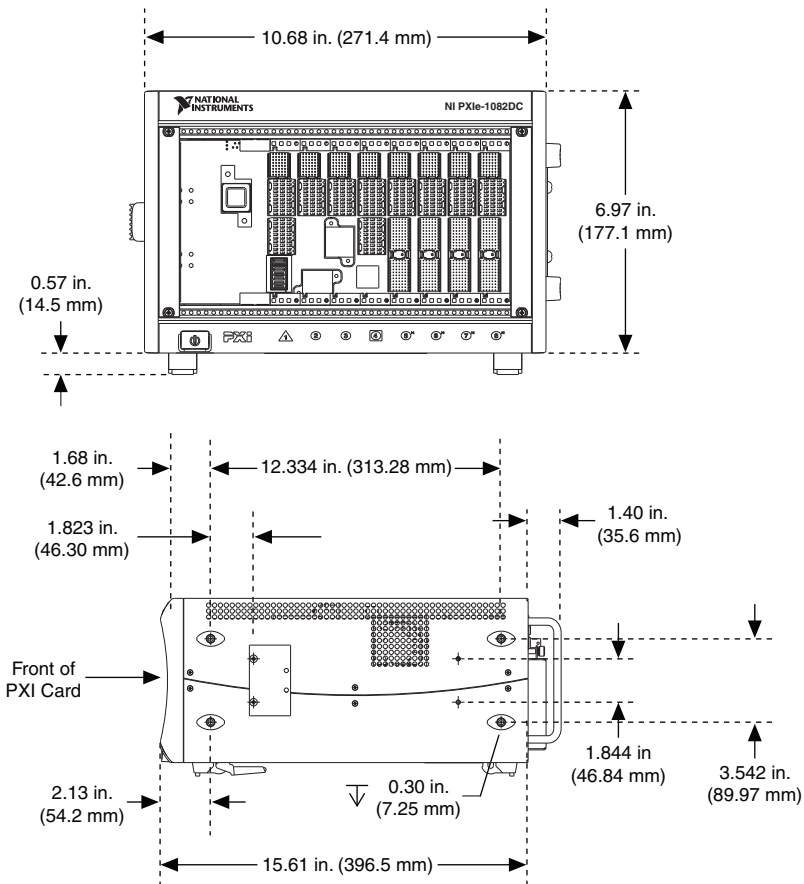

Figure A-2. NI PXIe-1082DC Chassis Dimensions (Bottom)

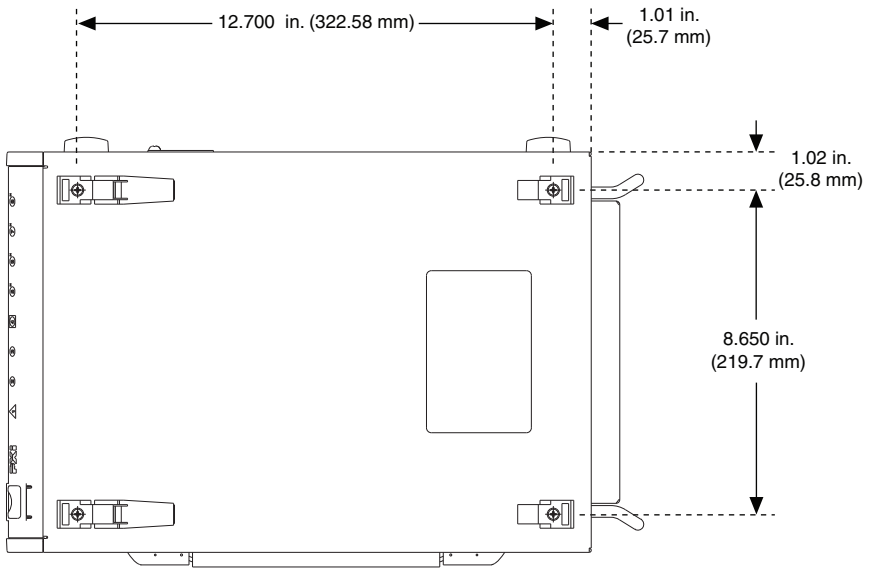
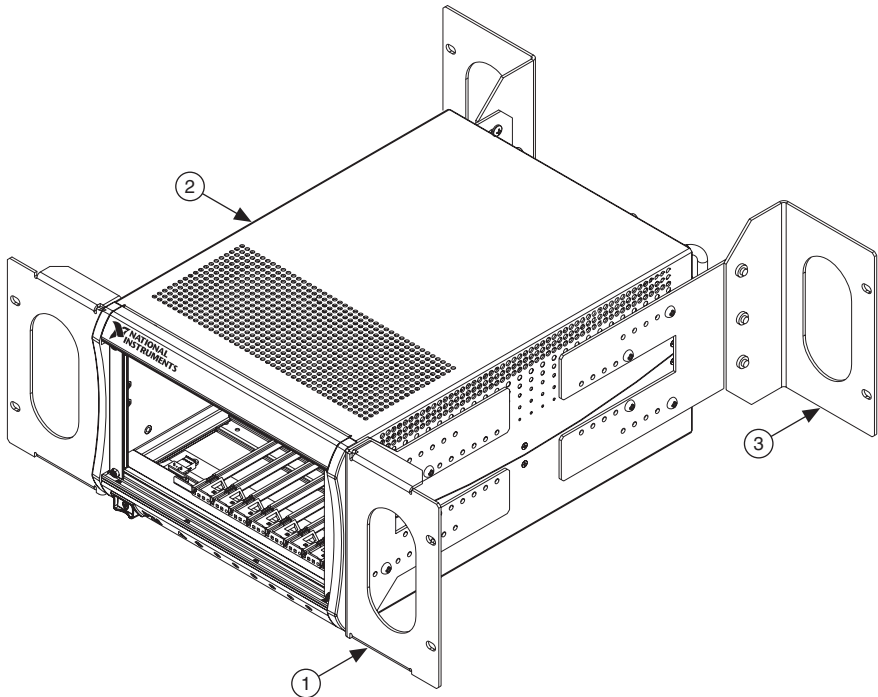

Figure A-3 shows the chassis rack mount kit components.

Figure A-3. NI Chassis Rack Mount Kit Components



1 Front Rack Mount Kit

2 NI Chassis

3 Optional Rear Rack Mount Kit



Note The chassis shown in Figure A-3 is representative of the NI PXI-1042/NI PXIe-1062Q/NI PXIe-1082DC product lines.

Pinouts

This appendix describes the connector pinouts for the NI PXIe-1082DC chassis backplane.

Table B-1 shows the XP1 Connector Pinout for the System Controller slot.

Table B-2 shows the XP2 Connector Pinout for the System Controller slot.

Table B-3 shows the XP3 Connector Pinout for the System Controller slot.

Table B-4 shows the XP4 Connector Pinout for the System Controller slot.

Table B-5 shows the TP2 Connector Pinout for the System Timing slot.

Table B-6 shows the XP3 Connector Pinout for the System Timing slot.

Table B-7 shows the XP4 Connector Pinout for the System Timing slot.

Table B-8 shows the P1 Connector Pinout for the Hybrid peripheral slots.

Table B-9 shows the XP3 Connector Pinout for the Hybrid peripheral slots.

Table B-10 shows the XP4 Connector Pinout for the Hybrid peripheral slots.

For more detailed information, refer to the *PXI-5 PXI Express Hardware Specification*, Revision 2.0. Contact the PXI Systems Alliance for a copy of the specification.

System Controller Slot Pinouts

Table B-1. XP1 Connector Pinout for the System Controller Slot

Pins	Signals
A	GND
B	3.3V
C	5V
D	GND
E	12V

Table B-1. XP1 Connector Pinout for the System Controller Slot

Pins	Signals
F	12V
G	GND

Table B-2. XP2 Connector Pinout for the System Controller Slot

Pin	A	B	ab	C	D	cd	E	F	ef
1	3PET p1	3PET n1	GND	3PER p1	3PER n1	GND	3PET p2	3PET n2	GND
2	3PET p3	3PET n3	GND	3PER p3	3PER n3	GND	3PER p2	3PER n2	GND
3	4PET p0	4PET n0	GND	4PER p0	4PER n0	GND	4PET p1	4PET n1	GND
4	4PET p2	4PET n2	GND	4PER p2	4PER n2	GND	4PER p1	4PER n1	GND
5	4PET p3	4PET n3	GND	4PER p3	4PER n3	GND	RSV	RSV	GND
6	RSV	RSV	GND	RSV	RSV	GND	RSV	RSV	GND
7	RSV	RSV	GND	RSV	RSV	GND	RSV	RSV	GND
8	RSV	RSV	GND	RSV	RSV	GND	RSV	RSV	GND
9	RSV	RSV	GND	RSV	RSV	GND	RSV	RSV	GND
10	RSV	RSV	GND	RSV	RSV	GND	RSV	RSV	GND

Table B-3. XP3 Connector Pinout for the System Controller Slot

Pin	A	B	ab	C	D	cd	E	F	ef
1	RSV	RSV	GND	RSV	RSV	GND	RSV	RSV	GND
2	RSV	RSV	GND	PWR_ OK	PS_ O N#	GND	LINK CAP	PWRB TN#	GND
3	SMB DAT	SMB CLK	GND	4RefCl k+	4RefCl k-	GND	2RefCl k+	2RefCl k-	GND

Table B-3. XP3 Connector Pinout for the System Controller Slot (Continued)

Pin	A	B	ab	C	D	cd	E	F	ef
4	RSV	PER ST#	GND	3RefCl k+	3RefCl k-	GND	1RefCl k+	1RefCl k-	GND
5	1PET p0	1PET n0	GND	1PER p0	1PER n0	GND	1PET p1	1PET n1	GND
6	1PET p2	1PET n2	GND	1PER p2	1PER n2	GND	1PER p1	1PER n1	GND
7	1PET p3	1PET n3	GND	1PER p3	1PER n3	GND	2PET p0	2PET n0	GND
8	2PET p1	2PET n1	GND	2PER p1	2PER n1	GND	2PER p0	2PER n0	GND
9	2PET p2	2PET n2	GND	2PER p2	2PER n2	GND	2PET p3	2PET n3	GND
10	3PET p0	3PET n0	GND	3PER p0	3PER n0	GND	2PER p3	2PER n3	GND

Table B-4. XP4 Connector Pinout for the System Controller Slot

Pin	Z	A	B	C	D	E	F
1	GND	GA4	GA3	GA2	GA1	GA0	GND
2	GND	5Vaux	GND	SYSEN#	WAKE#	ALERT#	GND
3	GND	RSV	RSV	RSV	RSV	RSV	GND
4	GND	RSV	RSV	RSV	RSV	RSV	GND
5	GND	PXI_ TRIG3	PXI_ TRIG4	PXI_ TRIG5	GND	PXI_ TRIG6	GND
6	GND	PXI_ TRIG2	GND	RSV	PXI_ STAR	PXI_ CLK10	GND
7	GND	PXI_ TRIG1	PXI_ TRIG0	RSV	GND	PXI_ TRIG7	GND
8	GND	RSV	GND	RSV	RSV	PXI_ LBR6	GND

System Timing Slot Pinouts

Table B-5. TP2 Connector Pinout for the System Timing Slot

Pin	A	B	ab	C	D	cd	E	F	ef
1	PXIe_ DSTAR C0+	PXIe_ DSTAR C0-	G N D	PXIe_ DSTAR C8+	PXIe_ DSTAR C8-	G N D	PXIe_ DSTAR B8+	PXIe_ DSTAR B8-	G N D
2	PXIe_ DSTAR A0+	PXIe_ DSTAR A0-	G N D	PXIe_ DSTAR C9+	PXIe_ DSTAR C9-	G N D	PXIe_ DSTAR A8+	PXIe_ DSTAR A8-	G N D
3	PXIe_ DSTAR B0+	PXIe_ DSTAR B0-	G N D	PXIe_ DSTAR C1+	PXIe_ DSTAR C1-	G N D	PXIe_ DSTAR A9+	PXIe_ DSTAR A9-	G N D
4	PXIe_ DSTAR B1+	PXIe_ DSTAR B1-	G N D	PXI_ STAR0	PXI_ STAR1	G N D	PXIe_ DSTAR B9+	PXIe_ DSTAR B9-	G N D
5	PXIe_ DSTAR A1+	PXIe_ DSTAR A1-	G N D	PXI_ STAR2	PXI_ STAR3	G N D	PXIe_ DSTAR C10+	PXIe_ DSTAR C10-	G N D
6	PXIe_ DSTAR C2+	PXIe_ DSTAR C2-	G N D	PXI_ STAR4	PXI_ STAR5	G N D	PXIe_ DSTAR A10+	PXIe_ DSTAR A10-	G N D
7	PXIe_ DSTAR B2+	PXIe_ DSTAR B2-	G N D	PXI_ STAR6	NC	G N D	PXIe_ DSTAR B10+	PXIe_ DSTAR B10-	G N D
8	PXIe_ DSTAR A2+	PXIe_ DSTAR A2-	G N D	NC	NC	G N D	PXIe_ DSTAR C11+	PXIe_ DSTAR C11-	G N D
9	NC	NC	G N D	NC	NC	G N D	PXIe_ DSTAR A11+	PXIe_ DSTAR A11-	G N D
10	NC	NC	G N D	NC	NC	G N D	PXIe_ DSTAR B11+	PXIe_ DSTAR B11-	G N D

Table B-6. XP3 Connector Pinout for the System Timing Slot

Pin	A	B	ab	C	D	cd	E	F	ef
1	PXIe_ CLK1 00+	PXIe_ CLK1 00-	G N D	PXIe_ SYNC1 00+	PXIe_ SYNC1 00-	G N D	PXIe_ DSTAR C+	PXIe_ DSTA RC-	G N D
2	PRSN T#	PWRE N#	G N D	PXIe_ DSTAR B+	PXIe_ DSTAR B-	G N D	PXIe_ DSTAR A+	PXIe_ DSTA RA-	G N D
3	SMBD AT	SMBC LK	G N D	RSV	RSV	G N D	RSV	RSV	G N D
4	MPW RGD*	PERS T#	G N D	RSV	RSV	G N D	1Ref Clk+	1Ref Clk-	G N D
5	1PET p0	1PET n0	G N D	1PER p0	1PER n0	G N D	1PET p1	1PET n1	G N D
6	1PET p2	1PET n2	G N D	1PER p2	1PER n2	G N D	1PER p1	1PER n1	G N D
7	1PET p3	1PET n3	G N D	1PER p3	1PER n3	G N D	1PET p4	1PET n4	G N D
8	1PET p5	1PET n5	G N D	1PER p5	1PER n5	G N D	1PER p4	1PER n4	G N D
9	1PET p6	1PET n6	G N D	1PER p6	1PER n6	G N D	1PET p7	1PET n7	G N D
10	RSV	RSV	G N D	RSV	RSV	G N D	1PER p7	1PER n7	G N D

Table B-7. XP4 Connector Pinout for the System Timing Slot

Pin	Z	A	B	C	D	E	F
1	GND	GA4	GA3	GA2	GA1	GA0	GND
2	GND	5Vaux	GND	SYSEN#	WAKE#	ALERT#	GND
3	GND	12V	12V	GND	GND	GND	GND
4	GND	GND	GND	3.3V	3.3V	3.3V	GND
5	GND	PXI_ TRIG3	PXI_ TRIG4	PXI_ TRIG5	GND	PXI_ TRIG6	GND
6	GND	PXI_ TRIG2	GND	ATNLED	PXI_ CLK10_ IN	PXI_ CLK10	GND
7	GND	PXI_ TRIG1	PXI_ TRIG0	ATNSW#	GND	PXI_ TRIG7	GND
8	GND	PXIe_ SYNC_ CTRL	GND	RSV	PXI_ LBL6	PXI_ LBR6	GND

Hybrid Slot Pinouts

Table B-8. P1 Connector Pinout for the Hybrid Slot

Pin	Z	A	B	C	D	E	F
25	GND	5V	REQ64#	ENUM#	3.3V	5V	GND
24	GND	AD[1]	5V	V(I/O)	AD[0]	ACK64#	GND
23	GND	3.3V	AD[4]	AD[3]	5V	AD[2]	GND
22	GND	AD[7]	GND	3.3V	AD[6]	AD[5]	GND
21	GND	3.3V	AD[9]	AD[8]	M66EN	C/BE[0]#	GND
20	GND	AD[12]	GND	V(I/O)	AD[11]	AD[10]	GND
19	GND	3.3V	AD[15]	AD[14]	GND	AD[13]	GND
18	GND	SERR#	GND	3.3V	PAR	C/BE[1]#	GND
17	GND	3.3V	IPMB_SCL	IPMB_SDA	GND	PERR#	GND
16	GND	DEVSEL#	GND	V(I/O)	STOP#	LOCK#	GND

Table B-8. P1 Connector Pinout for the Hybrid Slot (Continued)

Pin	Z	A	B	C	D	E	F
15	GND	3.3V	FRAME#	IRDY#	BD_SEL#	TRDY#	GND
12–14	Key Area						
11	GND	AD[18]	AD[17]	AD[16]	GND	C/BE[2]#	GND
10	GND	AD[21]	GND	3.3V	AD[20]	AD[19]	GND
9	GND	C/BE[3]#	IDSEL	AD[23]	GND	AD[22]	GND
8	GND	AD[26]	GND	V(I/O)	AD[25]	AD[24]	GND
7	GND	AD[30]	AD[29]	AD[28]	GND	AD[27]	GND
6	GND	REQ#	GND	3.3V	CLK	AD[31]	GND
5	GND	BRSVP1A5	BRSVP1B5	RST#	GND	GNT#	GND
4	GND	IPMB_PWR	HEALTHY#	V(I/O)	INTP	INTS	GND
3	GND	INTA#	INTB#	INTC#	5V	INTD#	GND
2	GND	TCK	5V	TMS	TDO	TDI	GND
1	GND	5V	-12V	TRST#	+12V	5V	GND

Table B-9. XP3 Connector Pinout for the Hybrid Slot

Pin	A	B	ab	C	D	cd	E	F	ef
1	PXIe_ CLK 100+	PXIe_ CLK 100-	G N D	PXIe_ SYNC 100+	PXIe_ SYNC 100-	G N D	PXIe_ DSTAR C+	PXIe_ DSTAR C-	G N D
2	PRSNT #	PWRE N#	G N D	PXIe_ DSTAR B+	PXIe_ DSTAR B-	G N D	PXIe_ DSTAR A+	PXIe_ DSTAR A-	G N D
3	SMBD AT	SMBC LK	G N D	RSV	RSV	G N D	RSV	RSV	G N D
4	MPWR GD*	PERS T#	G N D	RSV	RSV	G N D	1Ref Clk+	1Ref Clk-	G N D

Table B-9. XP3 Connector Pinout for the Hybrid Slot (Continued)

Pin	A	B	ab	C	D	cd	E	F	ef
5	1PET p0	1PET n0	G N D	1PERp0	1PERn0	G N D	1PETp1	1PETn1	G N D
6	1PET p2	1PET n2	G N D	1PERp2	1PERn2	G N D	1PERp1	1PERn1	G N D
7	1PET p3	1PET n3	G N D	1PERp3	1PERn3	G N D	1PETp4	1PETn4	G N D
8	1PET p5	1PET n5	G N D	1PERp5	1PERn5	G N D	1PERp4	1PERn4	G N D
9	1PET p6	1PET n6	G N D	1PERp6	1PERn6	G N D	1PETp7	1PETn7	G N D
10	RSV	RSV	G N D	RSV	RSV	G N D	1PERp7	1PERn7	G N D

Table B-10. XP4 Connector Pinout for the Hybrid Slot

Pin	Z	A	B	C	D	E	F
1	GND	GA4	GA3	GA2	GA1	GA0	GND
2	GND	5Vaux	GND	SYSEN#	WAKE#	ALERT#	GND
3	GND	12V	12V	GND	GND	GND	GND
4	GND	GND	GND	3.3V	3.3V	3.3V	GND
5	GND	PXI_ TRIG3	PXI_ TRIG4	PXI_ TRIG5	GND	PXI_ TRIG6	GND
6	GND	PXI_ TRIG2	GND	ATNLED	PXI_ STAR	PXI_ CLK10	GND

Table B-10. XP4 Connector Pinout for the Hybrid Slot (Continued)

Pin	Z	A	B	C	D	E	F
7	GND	PXI_ TRIG1	PXI_ TRIG0	ATNSW#	GND	PXI_ TRIG7	GND
8	GND	RSV	GND	RSV	PXI_ LBL6	PXI_ LBR6	GND

NI Services

National Instruments provides global services and support as part of our commitment to your success. Take advantage of product services in addition to training and certification programs that meet your needs during each phase of the application life cycle; from planning and development through deployment and ongoing maintenance.

To get started, register your product at ni.com/myproducts.

As a registered NI product user, you are entitled to the following benefits:

- Access to applicable product services.
- Easier product management with an online account.
- Receive critical part notifications, software updates, and service expirations.

Log in to your National Instruments ni.com User Profile to get personalized access to your services.

Services and Resources

- **Maintenance and Hardware Services**—NI helps you identify your systems' accuracy and reliability requirements and provides warranty, sparing, and calibration services to help you maintain accuracy and minimize downtime over the life of your system. Visit ni.com/services for more information.
 - **Warranty and Repair**—All NI hardware features a one-year standard warranty that is extendable up to five years. NI offers repair services performed in a timely manner by highly trained factory technicians using only original parts at a National Instruments service center.
 - **Calibration**—Through regular calibration, you can quantify and improve the measurement performance of an instrument. NI provides state-of-the-art calibration services. If your product supports calibration, you can obtain the calibration certificate for your product at ni.com/calibration.
- **System Integration**—If you have time constraints, limited in-house technical resources, or other project challenges, National Instruments Alliance Partner members can help. To learn more, call your local NI office or visit ni.com/alliance.

- **Training and Certification**—The NI training and certification program is the most effective way to increase application development proficiency and productivity. Visit ni.com/training for more information.
 - The Skills Guide assists you in identifying the proficiency requirements of your current application and gives you options for obtaining those skills consistent with your time and budget constraints and personal learning preferences. Visit ni.com/skills-guide to see these custom paths.
 - NI offers courses in several languages and formats including instructor-led classes at facilities worldwide, courses on-site at your facility, and online courses to serve your individual needs.
- **Technical Support**—Support at ni.com/support includes the following resources:
 - **Self-Help Technical Resources**—Visit ni.com/support for software drivers and updates, a searchable KnowledgeBase, product manuals, step-by-step troubleshooting wizards, thousands of example programs, tutorials, application notes, instrument drivers, and so on. Registered users also receive access to the NI Discussion Forums at ni.com/forums. NI Applications Engineers make sure every question submitted online receives an answer.
 - **Software Support Service Membership**—The Standard Service Program (SSP) is a renewable one-year subscription included with almost every NI software product, including NI Developer Suite. This program entitles members to direct access to NI Applications Engineers through phone and email for one-to-one technical support, as well as exclusive access to online training modules at ni.com/self-paced-training. NI also offers flexible extended contract options that guarantee your SSP benefits are available without interruption for as long as you need them. Visit ni.com/ssp for more information.
- **Declaration of Conformity (DoC)**—A DoC is our claim of compliance with the Council of the European Communities using the manufacturer’s declaration of conformity. This system affords the user protection for electromagnetic compatibility (EMC) and product safety. You can obtain the DoC for your product by visiting ni.com/certification.

For information about other technical support options in your area, visit ni.com/services, or contact your local office at ni.com/contact.

You also can visit the Worldwide Offices section of ni.com/niglobal to access the branch office websites, which provide up-to-date contact information, support phone numbers, email addresses, and current events.

Glossary

Symbol	Prefix	Value
p	pico	10^{-12}
n	nano	10^{-9}
μ	micro	10^{-6}
m	milli	10^{-3}
k	kilo	10^3
M	mega	10^6
G	giga	10^9
T	tera	10^{12}

Symbols

°	Degrees.
≥	Equal or greater than.
≤	Equal or less than.
%	Percent.

A

A	Amperes.
AC	Alternating current.
ANSI	American National Standards Institute.
Auto	Automatic fan speed control.
AWG	American Wire Gauge.

B

backplane	An assembly, typically a printed circuit board, with connectors and signal paths that bus the connector pins.
BNC	Bayonet Neill Concelman connector; a commonly used coaxial connector.

C

C	Celsius.
cfm	Cubic feet per minute.
CFR	Code of Federal Regulations.
cm	Centimeters.
CompactPCI	An adaptation of the Peripheral Component Interconnect (PCI) Specification 2.1 or later for industrial and/or embedded applications requiring a more robust mechanical form factor than desktop PCI. It uses industry standard mechanical components and high-performance connector technologies to provide an optimized system intended for rugged applications. It is electrically compatible with the PCI Specification, which enables low-cost PCI components to be utilized in a mechanical form factor suited for rugged environments.
CSA	Canadian Standards Association.

D

daisy-chain	A method of propagating signals along a bus, in which the devices are prioritized on the basis of their position on the bus.
DB-9	A 9-pin D-SUB connector.
DC	Direct current.
DoC	Declaration of Conformity.
D-SUB	Subminiature D connector.

E

efficiency	Ratio of output power to input power, expressed as a percentage.
EIA	Electronic Industries Association.
EMC	Electromagnetic Compatibility.
EMI	Electromagnetic Interference.

F

FCC	Federal Communications Commission.
filler panel	A blank module front panel used to fill empty slots in the chassis.

G

g	(1) grams; (2) a measure of acceleration equal to 9.8 m/s^2 .
GPIB	General Purpose Interface Bus (IEEE 488).
g_{RMS}	A measure of random vibration. The root mean square of acceleration levels in a random vibration test profile.

H

hr	Hours.
Hz	Hertz; cycles per second.

I

IEC	International Electrotechnical Commission; an organization that sets international electrical and electronics standards.
IEEE	Institute of Electrical and Electronics Engineers.
I_{MP}	Mainframe peak current.

Glossary

in. Inches.

inhibit To turn off.

J

jitter A measure of the small, rapid variations in clock transition times from their nominal regular intervals. Units: seconds RMS.

K

kg Kilograms.

km Kilometers.

L

lb Pounds.

LED Light emitting diode.

line regulation The maximum steady-state percentage that a DC voltage output will change as a result of a specified change in input AC voltage (step change from 90 to 132 VAC or 180 to 264 VAC).

load regulation The maximum steady-state percentage that a DC voltage output will change as a result of a step change from no-load to full-load output current.

M

m Meters.

MHz Megahertz. One million Hertz; one Hertz equals one cycle per second.

mi Miles.

ms Milliseconds.

MTBF Mean time between failure.

MTTR Mean time to repair.

N

NEMA	National Electrical Manufacturers Association.
NI	National Instruments.

P

power supply shuttle	A removable module that contains the chassis power supply.
PXI	PCI eXtensions for Instrumentation.
PXI_CLK10	10 MHz PXI system reference clock.

R

RH	Relative humidity.
RMS	Root mean square.

S

s	Seconds.
skew	Deviation in signal transmission times.
slot blocker	An assembly installed into an empty slot to improve the airflow in adjacent slots.
standby	The backplane is unpowered (off), but the chassis is still connected to AC power mains.
System controller	A module configured for installation in Slot 1 of a PXI chassis. This device is unique in the PXI system in that it performs the system controller functions, including clock sourcing and arbitration for data transfers across the backplane. Installing such a device into any other slot can damage the device, the PXI backplane, or both.

Glossary

system reference clock A 10 MHz clock, also called PXI_CLK10, that is distributed to all peripheral slots in the chassis, as well as a BNC connector on the rear of chassis labeled *10 MHz REF OUT*. The system reference clock can be used for synchronization of multiple modules in a measurement or control system. The 10 MHz REF IN and OUT BNC connectors on the rear of the chassis can be used to synchronize multiple chassis to one reference clock. The PXI backplane specification defines implementation guidelines for PXI_CLK10.

System Timing slot This slot is located at slot 4 and has dedicated trigger lines to other slots.

T

TTL Transistor-transistor logic.

U

UL Underwriter's Laboratories.

V

V Volts.

VAC Volts alternating current.

V_{pp} Peak-to-peak voltage.

W

W Watts.

Index

B

backplane

- hybrid peripheral slots, 1-6
- interoperability with CompactPCI, 1-5
- overview, 1-5
- PXI Express peripheral slots, 1-6
- PXI local bus, routing, 1-8
- PXIe_SYNC_CTRL, 1-11
- specifications, A-6
- system controller slot, 1-6
- system reference clock, 1-9
 - default behavior (figure), 1-10
- system timing slot, 1-7
- trigger bus, 1-9

C

- CE compliance, specifications, A-5
- chassis ambient temperature definitions, 2-3
- chassis cooling considerations
 - ambient temperature definitions, 2-3
 - clearances, 2-2
 - figure, 2-2
 - vents (figure), 2-3
- chassis initialization file, 2-12
- chassis ventilation (figure), 2-3
- clearances for chassis cooling, 2-2
 - figure, 2-2
- CLK10 rear connectors, 2-10
- CompactPCI, interoperability with NI
 - PXIe-1082DC backplane, 1-5
- configuration in MAX (figure), 2-11
- configuration. *See* installation, configuration, and operation
- connector pinouts. *See* pinouts
- cooling setting fan speed, 2-3

D

- DB-9 connector
 - pinout (table), 2-8
 - power supply voltages (table), 2-9

- dimensions (figure), A-9, A-10
- documentation related documentation, ix

E

- electromagnetic compatibility, A-5
- environmental management, specifications
 - WEEE information, A-6
- external clock source specifications, A-7

F

- fan, setting speed, 2-3

G

- ground, connecting, 2-4

H

- hybrid peripheral slots, description, 1-6
- hybrid slot pinouts
 - P1 connector (table), B-6
 - XP3 connector (table), B-7
 - XP4 connector (table), B-8

I

- IEC 320 inlet, 1-4, 2-4
- inhibit mode switch, 2-10
- installation, configuration, and operation
 - chassis initialization file, 2-12
 - configuration in MAX (figure), 2-11
 - connecting safety ground, 2-4
 - installing a PXI Express system controller, 2-4
 - figure, 2-5
 - module installation
 - CompactPCI or PXI modules (figure), 2-7
 - peripheral module installation, 2-6
 - figure, 2-7
 - PXI Express configuration in MAX, 2-10

- PXI Express system controller installed
 - in a NI PXIe-1082DC chassis (figure), 2-6
- PXI-1 configuration in MAX, 2-11
- rack mounting, 2-3
- remote voltage monitoring and inhibiting interface, 2-8
- setting fan speed, 2-3
- site considerations, 2-2
- testing power up, 2-4
- unpacking the NI PXIe-1082DC, 1-1
- installing a PXI Express system controller (figure), 2-5
- interoperability with CompactPCI, 1-5

K

- key features, 1-1
- kit contents, 1-1

M

- maintenance of NI PXIe-1082DC chassis
 - cleaning
 - exterior cleaning, 3-2
 - interior cleaning, 3-1
 - preparation, 3-1
 - resetting the DC mains circuit breaker, 3-2
 - service interval, 3-1

N

- NI PXIe-1082DC
 - fan speed, setting, 2-3
 - front view (figure), 1-3
 - installation. *See* installation, configuration, and operation
 - key features, 1-1
 - optional equipment, 1-4
 - rack mounting, 2-3
 - rear view (figure), 1-4
 - safety ground, connecting, 2-4
 - unpacking, 1-1

- NI PXIe-1082DC backplane
 - interoperability with CompactPCI, 1-5
 - local bus, 1-8
 - overview, 1-5
 - peripheral slots
 - hybrid, 1-6
 - PXI Express, 1-6
 - PXIe_SYNC_CTRL, 1-11
 - specifications, A-6
 - system controller slot, 1-6
 - system reference clock, 1-9
 - default behavior, 1-10
 - system timing slot, 1-7
 - trigger bus, 1-9

O

- optional equipment, 1-4

P

- peripheral module installation
 - figure, 2-7
- pinouts, B-1
 - DB-9 connector (table), 2-8
- power inhibit switch LED indicator, 2-8
- power on, testing, 2-4
- power supply
 - connecting to, 2-4
 - remote voltage monitoring and inhibiting interface, 2-8
 - replacing, 3-3
 - configuration, 3-3
 - connecting to power source, 3-3
 - installation, 3-3
 - removal, 3-3
 - voltages at voltage monitoring connector (DB-9) (table), 2-8
- PXI differential star trigger specifications (PXIe-DSTARA, PXIe-DSTARB, PXIe-DSTARC), A-8
- PXI Express configuration in MAX, 2-10
- PXI Express peripheral slots, description, 1-6
- PXI Express system controller, 2-4
 - figure, 2-5
 - installing in a NI PXIe-1082DC chassis (figure), 2-6

- PXI local bus, routing, 1-8
- PXI star trigger specifications, A-8
- PXI star, routing, 1-8
- PXI trigger bus, routing (figure), 1-9
- PXI-1 configuration in MAX, 2-11
- PXIe_DSTAR, routing, 1-8
- PXIe_SYNC_CTRL, 1-11
 - specifications, A-8
 - using as restart (figure), 1-11

R

- rack mount kit dimensions (figure), A-11
- rack mounting, 2-3
 - kit, 1-4
- recycling hardware, A-6
- related documentation, *ix*
- remote voltage monitoring and inhibiting interface, 2-8
- replacing the power supply, 3-3

S

- safety and caution notices, 2-1
- safety ground, connecting, 2-4
- safety, specifications, A-5
- service interval, 3-1
- setting fan speed, 2-3
- specifications
 - acoustic emissions
 - sound power, A-4
 - sound pressure level (at operator position), A-4
 - backplane
 - 10 MHz system reference clock (PXI_CLK10), A-6
 - 100 MHz Reference Out BNC, A-7
 - 100 MHz system reference clock (PXIe_CLK100 and PXIe_SYNC100), A-7
 - CE compliance, A-5
 - chassis cooling, A-3
 - dimensions (figure), A-9, A-10
 - electrical
 - DC input, A-1
 - DC output, A-2

- electromagnetic compatibility, A-5
- environmental
 - operating environment, A-4
 - storage environment, A-4
- environmental management
 - WEEE information, A-6
- external clock source, A-7
- mechanical, A-8
- online product certification, A-5
- PXI differential star triggers (PXIe-DSTARA, PXIe-DSTARB, PXIe-DSTARC), A-8
- PXI star trigger, A-8
- PXIe_SYNC_CTRL, A-8
- rack mount kit dimensions (figure), A-11
- safety, A-5
- shock and vibration, A-4
- system reference clocks, A-6
- static discharge damage (caution), 3-1
- system controller slot
 - description, 1-6
 - pinouts
 - XP1 connector (table), B-1
 - XP2 connector (table), B-2
 - XP3 connector (table), B-2
 - XP4 connector (table), B-3
- system reference clock, 1-9
 - default behavior (figure), 1-10
 - specifications, A-6
- system timing slot
 - description, 1-7
 - pinouts
 - TP2 connector (table), B-4
 - XP3 connector (table), B-5
 - XP4 connector (table), B-6

T

- testing power up, 2-4
- trigger bus, 1-9

U

- unpacking the NI PXIe-1082DC chassis, 1-1

V

voltage monitoring connector. *See* DB-9 connector
voltages at voltage monitoring connector (DB-9) (table), 2-9

W

WEEE information, A-6