

Avanti®

WINE COOLER INSTRUCTION MANUAL

Model Number:

WC400CL/WC401CL

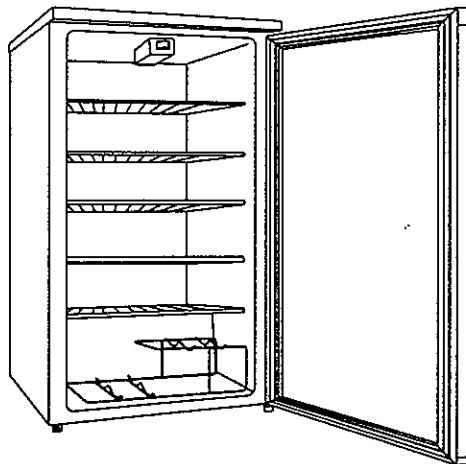

CAUTION:

**BEFORE USE, PLEASE READ AND FOLLOW ALL SAFETY
RULES AND OPERATING INSTRUCTIONS.**

Avanti has a policy of continuous improvement on its products and reserves the right to change materials and specifications without notice.

Avanti Products, A Division of The Mackle Co., Inc.
P.O. Box 520604 - Miami, Florida 33152
www.avantiproductions.com

Warranty Information

Thank you for purchasing this fine Avanti product. Please fill out this card and return it within 100 days of purchase and receive these important benefits:

➤ **Confirm your warranty:**

Your prompt product registration confirms your right to the protection available under the terms and conditions of your Avanti warranty.

➤ **Protect your product:**

We will keep the model number and date of purchase of your new Avanti product on file to help you refer to this information in the event of an insurance claim such as fire or theft.

➤ **Promote better products:**

We value your input. Your response will help us develop products designed to best meet your future needs.

------(detach here)-----

Avanti Registration Card

Name	Model #	Serial #
Address	Date Purchased	Store/Dealer Name
City	State	Zip
Area Code	Phone Number	Occupation
As Your Primary Residence, Do You:		
<input type="checkbox"/> Own	<input type="checkbox"/> Rent	
Did You Purchase An Additional Warranty:		
<input type="checkbox"/> Extended	<input type="checkbox"/> Food Loss	<input type="checkbox"/> None
Reason For Choosing This Avanti Product:		
Please indicate the most important factors that influenced your decision to purchase this product.		
<input type="checkbox"/> Price	<input type="checkbox"/> Product Features	<input type="checkbox"/> Avanti Reputation
<input type="checkbox"/> Product Quality	<input type="checkbox"/> Salesperson Recommendation	<input type="checkbox"/> Friend/Relative Recommendation
<input type="checkbox"/> Warranty	<input type="checkbox"/> Other	
Marital Status:		
<input type="checkbox"/> Married	<input type="checkbox"/> Single	
Is This Product Used In The:		
<input type="checkbox"/> Home	<input type="checkbox"/> Business	
How Did You Learn About This Product:		
<input type="checkbox"/> Advertising	<input type="checkbox"/> Product Features	<input type="checkbox"/> In Store Demo
<input type="checkbox"/> Personal Demo	<input type="checkbox"/> Other	
Comments		

HELP US HELP YOU...

Read this guide carefully.

It is intended to help you operate and maintain your new wine cooler properly.

Keep it handy to answer your questions. If you don't understand something or you need more help, please call:

**Avanti Customer Service
800-220-5570**

Keep proof of original purchase date (such as your sales slip) with this guide to establish the warranty period.

CAUTION:

**THIS WINE COOLER IS
NOT DESIGNED FOR
THE STORAGE OF
MEDICINE OR OTHER
MEDICAL PRODUCTS.**

Write down the model and serial numbers.

You'll find them on a plate located on the rear wall outside the wine cooler.

Please write these numbers here:

Date of Purchase

Model Number

Serial Number

Use these numbers in any correspondence or service calls concerning your wine cooler.

If you received a damaged wine cooler, immediately contact the dealer (or builder) that sold you the wine cooler.

Save time and money. Before you call for service, check the Troubleshooting Guide. It lists causes of minor operating problems that you can correct yourself.

IF YOU NEED SERVICE

We're proud of our service and want you to be pleased. If for some reason you are not happy with the service you receive, here are some steps to follow for further help.

FIRST, contact the people who serviced your appliance. Explain why you are not pleased. In most cases, this will solve the problem.

NEXT, if you are still not pleased, write all the details, including your telephone number, and send to:

Customer Service
Avanti Products
10880 NW 30 Street
Miami, FL 33172

PARTS AND FEATURES

REVERSIBLE DOOR



ADJUSTABLE
THERMOSTAT

FLUSH BACK
DESIGN

ADDITIONAL
SPACE FOR
LARGE BOTTLES

ADDITIONAL
WINE RACK

ADJUSTABLE LEVELING LEG

INTERIOR LAMP
WITH ON/OFF
SWITCH

VINYL COATED
SLIDE OUT
SHELVES

TEMPERED-GLASS
DOOR

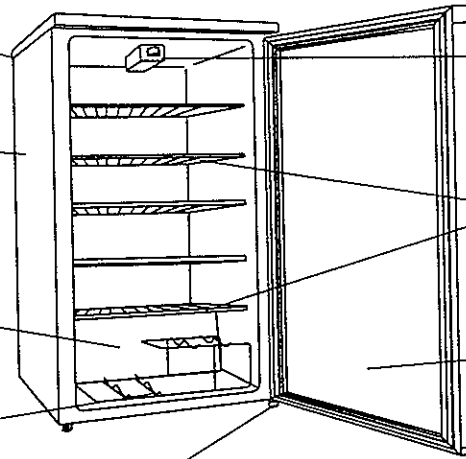

Table of Contents

Help Us Help You	2
Parts and Features	3
Important Safety Instructions	5
Installation Instructions	5
Before Using Your Wine Cooler	5
Installation of Your Wine Cooler	5
Reversing the Door Swing of Your Wine Cooler	6
Operating Your Wine Cooler	7
Temperature Control	7
Care and Maintenance	7
Changing Your Light Bulb	7
Cleaning Your Wine Cooler	8
Maintenance of Your Wine Cooler	8
Vacation Time	8
Moving Your Wine Cooler	8
Water Collection Tray	8
Lock on door	8
Wine Rack	8
Troubleshooting Guide	9
Service For Your Wine Cooler	10
Your Avanti Products Warranty	11
WC400CL/WC401CL Parts Breakdown	12
WC400CL/WC401CL Parts List	13
WC400CL/WC401CL Wiring Diagram and Cooling System	14

Important Safety Instructions

⚠️ WARNING ⚡

To reduce the risk of fire, electric shock, or injury when using your wine cooler, follow these basic precautions:

- Read all instructions before using the appliance.
- **DANGER or WARNING:** Risk of child entrapment.
- Child entrapment and suffocation are not problems of the past. Junked or abandoned appliances are still dangerous... even if they will "just sit in the garage a few days."
- **Before you throw away your old refrigerator or wine cooler:** Take off the doors, leave the shelves in place, so that children may not easily climb inside.
- Never allow children to operate, play with, or crawl inside the appliance.
- Never clean appliance parts with flammable fluids. The fumes can create a fire hazard or explosion.
- Do not store or use gasoline or any other flammable vapors and liquids in the vicinity of this or any other appliance. The fumes can create a fire hazard or explosion.

-Save these instructions-

INSTALLATION INSTRUCTIONS

➤ Before Using Your Wine Cooler

- Remove the exterior and interior packing.
- Check to be sure the following parts are included:
 - 6 slide out shelves
 - 2 Keys
 - Wine rack
 - Instruction manual
- Before connecting the appliance to the power source, let it stand upright for approximately 2 hours. This will reduce the possibility of a malfunction in the cooling system from handling during transportation.
- Clean the interior surface with lukewarm water using a soft cloth.

➤ Installation of Your Wine Cooler

- Place your appliance on a floor that is strong enough to support the appliance when it is fully loaded. To level your appliance, adjust the legs at the front of the appliance.
- Allow 6 inches of space between the back and sides of the appliance, which allows the proper air circulation to cool the compressor.
- Locate the appliance away from direct sunlight and sources of heat (stove, heater, radiator, etc.). Direct sunlight may affect the acrylic coating and heat sources may increase electrical consumption. Extreme cold ambient temperatures may also cause the appliance not to perform properly.
- Avoid locating the appliance in moist areas. Too much moisture in the air will cause frost to form quickly on the evaporator.
- Plug the appliance into an exclusive properly installed-grounded wall outlet. Do not under any circumstances cut or remove the third (ground) prong from the power cord. Any questions concerning power and or grounding should be directed toward a certified electrician or an authorized Avanti Products service center.

⚡ Warning ⚡

Improper use of the grounded plug can result in the risk of electrical shock. If the power cord is damaged, have it replaced by an authorized Avanti Products service center.

➤ Reversing the Door Swing of Your Wine Cooler

This wine cooler has the capability of either opening the door from the left or right side. The unit is delivered to you with the door opening from the left side. Should you desire to reverse the opening direction, please follow these instructions.

NOTE:

All parts removed must be saved to do the reinstallation of the door.
Reversing of the Wine Cooler Door

- Remove the two screws(1)that hold the lower hinge(2)(right side)to the frame. Also, remove the screw-type leveling front leg(3).
- Remove the left front leg(4) and transfer it to the right side.
- Lift the door and place it on a padded surface to prevent scratching it. Make sure to remove the spring(5) located inside the upper right hole of the door and the upper right side pin(6).
- Remove the plug button(7)from the upper left hole of the door and transfer it to the uncovered hole at the right side. Be sure to press the button firmly into the hole.
- Insert the upper pin(6) previously removed from the right side (step 3) and transfer it to the other hole at the left side of the top frame.
- Insert the spring(5)previously removed(step 3)inside the upper left side hole of the door.
- Set the door in its place making sure the pin(6)enters the bushing at the lower upper frame section(hole).
- While holding the door in the closed position, secure the lower left hinge(2)previously removed(step 1).Before placing this lower hinge, remove the upper bolt-pin(8) and reverse the direction of the hinge.
- Insert the bolt-pin(8)and do not tighten until the top of the door is leveled with the counter top.
- Insert the two screws(1)previously removed(step 1)and tighten them.

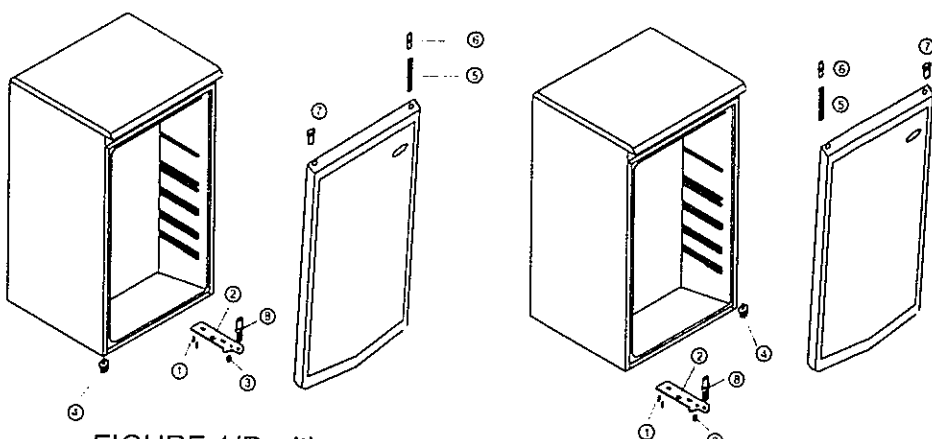

FIGURE 1(Position prior to door reversal)

FIGURE 2(Position after door reversal)

- ① -Door Hinge Screws
- ② -Lower Door Hinge
- ③ -Front Leveling Legs
- ④ -Left Front Leg

- ⑤ -Door Frame Spring
- ⑥ -Door Frame Pin
- ⑦ -Hinge Plug(Door Frame)Left Side
- ⑧ -Door Hinge Bolt

OPERATING YOUR WINE COOLER

► Temperature Control

- The first time you turn the unit on, set the temperature control to "MAX" position.
- The settings of the temperature control are "OFF", "MIN", "NORMAL" and "MAX". After 20 minutes, adjust the temperature control setting to "NORMAL". The setting of "NORMAL" should be correct for home or office wine cooler use.
- To turn the wine cooler off, turn the temperature control to "OFF".

NOTE:

- Turning the temperature control to "OFF" position stops the cooling cycle, but does not shut off the power to the wine cooler.
- If the unit is unplugged, power lost, or turned off, you must wait 3 to 5 minutes before restarting the unit. If you attempt to restart before this time delay, the wine cooler will not start.
- The range between "MIN" and "MAX" is from 48°F to 61°F, which is ideal for the storage of wines.

CARE AND MAINTENANCE

► CHANGING THE LIGHT BULB

NOTE:

All parts removed must be saved to do the replacement of the light bulb.

Before removing the light bulb, either unplug the refrigerator or disconnect the electricity leading into the refrigerator at the main power supply. Failure to do so could result in electrical shock or personal injury.

- Move the light switch⑤to the "OFF" position.
- Remove the screw⑥.

- Remove the light bulb cover 4 by pulling the bottom end of the light bulb cover gently.
- Unscrew the bulb 1.
- Replace with a 10 watt-refrigerator bulb that is the same shape and size.
- Replace the light bulb cover 4 and tighten screw 6.

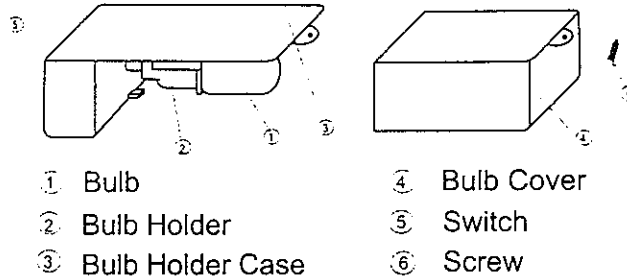

▶ Cleaning Your Wine Cooler

- Turn the temperature control to "OFF", unplug the wine cooler, and remove the bottles.
- Wash the inside with a warm water and baking soda solution. The solution should be about 2 tablespoons of baking soda to a quart of water.
- Wash the shelves and trays with a mild detergent solution.
- The outside of the wine cooler should be cleaned with mild detergent and warm water.
- It may also be necessary to periodically wipe the bottom part of the storage area, as the wine cooler is designed to retain humidity, and condensation may collect there.

▶ Maintenance of Your Wine cooler

• Power Failure

Most power failures are corrected within a few hours and should not affect the temperature of your wine cooler if you minimize the number of times the door is opened. If the power is going to be off for a longer period of time, you need to take the proper steps to protect your contents.

▶ Vacation Time

During long absences, remove all the bottles; unplug your wine cooler, clean your wine cooler, and leave the door open slightly to avoid possible formation of condensation, mold, or odors.

▶ Moving Your Wine Cooler

- Remove all the bottles.
- Securely tape down all loose items inside your wine cooler.
- Turn the leveling screws up to the base to avoid damage.
- Tape the doors shut.
- Be sure the wine cooler stays in the upright position during transportation.

▶ Water Collection Tray

- When the compressor is not operating, water drops collect and drain through the outlet in the inner back wall into the drain pan located above the compressor.
- To clean tray if necessary, remove 2 screws holding it against the back wall.
- Pull the tray forward and replace it once cleaned.

PROBLEMS WITH YOUR WINE COOLER?

You can solve many common wine cooler problems easily, saving you the cost of a possible service call. Try the suggestions below to see if you can solve the problem before calling the servicer.

TROUBLESHOOTING GUIDE

PROBLEM	POSSIBLE CAUSE
Wine cooler does not operate.	Not plugged in. The circuit breaker tripped or blown fuse. The wine cooler temperature control is set at "OFF".
Wine cooler is not cold enough.	Check to be sure the temperature control setting is at "NORMAL". External environment may require a higher setting. The door is opened too often. The door is not closed completely. The door gasket does not seal properly. The wine cooler does not have the correct clearances.
Compressor turns on and off frequently	The room temperature is hotter than normal. A large amount of contents has been added to the wine cooler. The door is opened too often. The door is not closed completely. The temperature control is not set correctly. The door gasket does not seal properly. The wine cooler does not have the correct clearances.
The light does not work.	The home circuit breaker or fuse has tripped. The wine cooler is unplugged. The bulb has burned out(see maintenance section for the replacement procedure). The switch is in the "OFF" position.
Vibrations.	Check to assure that the wine cooler is level.
The wine cooler seems to make too much noise.	The rattling noise may come from the flow of the refrigerant, which is normal. As each cycle ends, you may hear gurgling sounds caused by the flow of refrigerant in your wine cooler. Contraction and expansion of the inside walls may cause popping and crackling noises. The wine cooler is not level.
The door will not close properly.	The wine cooler is not level. The doors were reversed and not properly installed. The gasket is dirty. The shelves are out of position.

YOUR Avanti Products WARRANTY

Staple your sales receipt here. Proof of original purchase date is needed to obtain service under warranty.

WHAT IS COVERED LIMITED ONE-YEAR WARRANTY

For one year from the date of purchase by the original owner, Avanti Products will, at its option, repair or replace any part of the wine cooler which proves to be defective in material or workmanship under normal use. During this period Avanti Products will provide all parts and labor necessary to correct such defects free of charge, so long as the appliance has been installed and operated in accordance with the written instructions in this manual. In rental or commercial use, the warranty period is 90 days. All Avanti Appliances of 3.6 cubic feet capacity or less must be brought/sent to the appliance service shop for repair.

LIMITED SECOND THROUGH FIFTH YEAR WARRANTY

For the second through the fifth year from date of original purchase, Avanti Products will provide a replacement compressor free of charge due to a failure. You are responsible for the service labor and freight charges. In rental or commercial use, the limited compressor warranty is one year and nine months. Cost to move the appliance to the servicers' shop and back to the user's home, as may be required, are the user's responsibility.

WHAT IS NOT COVERED

- Content losses due to spoilage.
- Incidental or consequential damages.
- Parts and labor costs for the following will not be considered as warranty.
- Evaporator doors, door springs, and/or frames.
- Inner door panels, door shelves, door rails, and/or door supports.
- Vegetable crispers.
- Light bulbs and/or plastic housing.
- Plastic cabinet liners.
- Punctured evaporator that voids the warranty on the complete sealed system.
- Repairs performed by unauthorized servicers.
- Service calls that do not involve defects in material or workmanship such as customer education, door reversal, or proper installation.
- Service calls that are related to external problems, such as abuse, misuse, inadequate electrical power, accidents, fire, floods, or acts of God.
- Replacement of house fuses or resetting circuit breakers.
- Failure of the product if it is used for other than its intended purpose.
- This warranty does not apply in any foreign country.

➤ **Lock On Door**

- Your unit is provided with a lock and key combination.
- The key is located inside the plastic bag that contains User's Guide. Insert the key into the lock and turn it counterclockwise to unlock the door. To lock the door do the reverse operation making sure metal pin is engaged completely. Remove the key and place it in a secure place for safekeeping.

➤ **Wine Rack**

- There is an additional wine rack at the bottom section of the unit where you can store up to 4 wine bottles.
- This rack is removable for cleaning purposes.

SERVICE FOR YOUR WINE COOLER

We are proud of our customer service organization and the network of professional service technicians that provide service on your Avanti appliances. With the purchase of your Avanti appliance, you can have the confidence that if you ever need additional information or assistance, the Avanti Products Customer Service team will be here for you. Just call us toll-free.

AVANTI PRODUCTS CUSTOMER SERVICES

Product Information 800-323-5029	Whatever your questions are about our products, help is available.
Part Orders 800-220-5570	You may order parts and accessories that will be delivered directly to your home. You may order these items by personal check, money order, Master Card, or Visa.
In-Home Repair Service 800-220-5570	An Avanti Products authorized service center will provide expert repair service, scheduled at a time that is convenient for you. Our trained servicers know your appliance inside and out.