

FieldPoint™ Operating Instructions

cFP-RLY-423

Four-Channel SPDT Relay Module

These operating instructions describe how to install and use the National Instruments cFP-RLY-423. For more information about configuring and accessing the cFP-RLY-423 over a network, refer to the user manual for the FieldPoint network module you are using.

Features

The cFP-RLY-423 is a Compact FieldPoint relay output module with the following features:

- Four single-pole double-throw (SPDT) relay channels
- Switches up to 1.5 A at 35 VDC or 250 VAC
- LED relay status indicators
- Hot swappable
- -40 to 60 °C operation
- 250 V_{rms} maximum isolation voltage
- 2,300 V_{rms} transient overvoltage protection

Installing the cFP-RLY-423

The cFP-RLY-423 mounts on a Compact FieldPoint backplane (cFP-BP-*x*), which provides operating power to the module. Installing the cFP-RLY-423 onto a powered backplane does not disrupt the operation of the bank.

To install the cFP-RLY-423, refer to Figure 1 and complete the following steps:

1. Align the captive screws on the cFP-RLY-423 with the holes on the backplane. The alignment keys on the cFP-RLY-423 prevent backward insertion.
2. Press firmly to seat the cFP-RLY-423 on the backplane.
3. Using a number 2 Phillips screwdriver with a shank of at least 64 mm (2.5 in.) length, tighten the captive screws to $1.1 \text{ N} \cdot \text{m}$ (10 lb · in.) of torque. The nylon coating on the screws prevents them from loosening.

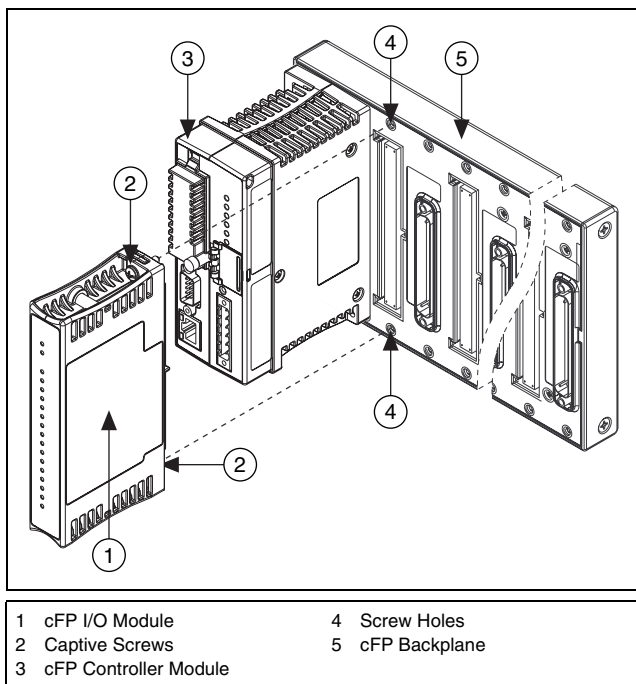

Figure 1. Installing the cFP-RLY-423

Wiring the cFP-RLY-423

The cFP-CB- x connector block has connections for each of the four cFP-RLY-423 relay channels and for an external supply to power field devices. If you are using the cFP-RLY-423 in a *hazardous voltage* application, you must use the cFP-CB-1 connector block or a suitable hazardous voltage cable. A hazardous voltage is a voltage greater than $42.4 V_{\text{peak}}$ or 60 VDC.



Caution Ensure that hazardous voltage wiring is performed only by qualified personnel adhering to local electrical standards.

Each relay channel of the cFP-RLY-423 has four terminals: one NO (normally open), one NC (normally closed), and two IC (isolated common).

Table 1 lists the terminal assignments for the signals of each channel.

Table 1. Terminal Assignments

Channel	Terminal Numbers		
	NO	IC	NC
0	1	2,3	4
1	5	6,7	8
2	9	10,11	12
3	13	14,15	16

All of the COM terminals are connected internally and all of the V_{SUP} terminals are connected internally. NI does not recommend using them with the cFP-RLY-423.

Table 2. V_{SUP} and COM Terminal Assignments

V_{SUP}	COM
17	18
19	20
21	22
23	24
25	26
27	28
29	30
31	32



Caution Cascading power between two modules defeats isolation between those modules. Cascading power from the network module defeats all isolation between modules in the FieldPoint bank.

Connecting Loads to the cFP-RLY-423

Connect two loads and an external power supply to one channel of the cFP-RLY-423 as shown in Figure 2. Install a 1.5 A, 250 V maximum, fast-acting fuse suitable for the load at the connected IC terminal to protect the module and the load from damage.

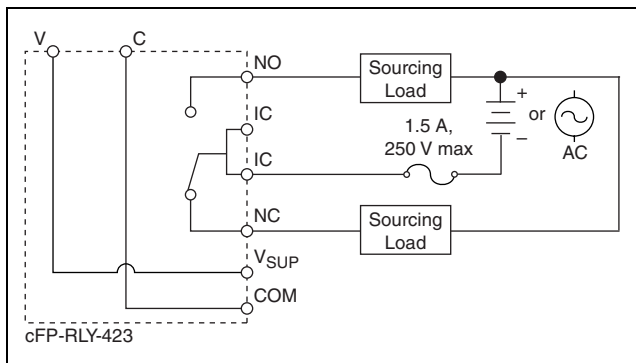

Figure 2. Basic Field Connection

The cFP-RLY-423 has four independent Form C electromechanical relays. The relays are break-before-make. At power-up, all relays are in the NC state. Turning the relay channel on breaks the NC–IC connection and makes the NO–IC connection. Each relay can be controlled independently, or all relays can change states simultaneously.

There is an effective resistance of up to 200 m Ω between IC and NC or NO. This resistance causes a voltage drop.¹ For example, if the current is 1.5 A, the voltage drop across the IC and NC or NO terminals can be as high as 0.3 V.

The amount of current the relay can switch depends on the voltage, the type of load, and the ambient temperature. Refer to the [Specifications](#) section for more information.

Protecting Contacts from Inductive Loads

When inductive loads are connected to the relays, a large counter-electromotive force can occur at relay switching time because of the energy stored in the inductive load. These flyback voltages can severely damage the relay contacts and greatly shorten the life of the relay.

It is best to limit flyback voltages by installing a flyback diode across an inductive DC load or a metal oxide varistor (MOV) across an inductive AC load. Refer to the [Guidelines for Selecting Contact Protection Circuits](#) section for more information.

In addition, the cFP-RLY-423 has internal protection MOVs to prevent excessively high voltage from being applied across the contacts. Each channel contains two MOVs: one between NC and IC and one between NO and IC. However, National Instruments recommends installing a protection circuit across any inductive load, as close as possible to the load. The flyback protection MOVs cause a small leakage current, which is detailed in the [Specifications](#) section.

¹ At the end of relay life, the path resistance rises rapidly above 1 Ω .

Guidelines for Selecting Contact Protection Circuits¹

Proper selection is critical as the use of a contact-protection device can extend contact life. When mounting the protection device, always locate it near the immediate area of the load or contact. Typically you should mount a protective device within 18 in. of the load or contact.

Typical contact-protection circuits are shown here as an overview, but you should thoroughly examine the circuit you are planning to use.

Diode and Zener Diode Circuit

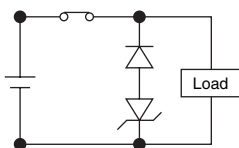
Diagram	Notes
	Use in DC applications only.
	Use when diode circuit causes too long release time.
	Use zener diode with zener voltage about equal to power supply voltage.

Diode Circuit

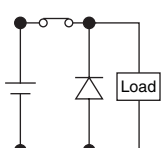
Diagram	Notes
	Use in DC applications only.
	Compared to RC type, circuit delays release time (2 to 5 times values stated in catalog).
	For larger voltages, use diode with reverse breakdown 10 times circuit voltage and forward load circuit.
	For smaller voltages, use reverse breakdown voltage of 2 to 3 times power supply voltage.

¹ This section has been reprinted with permission from American Zettler, Inc.

CR (RC or Snubber) Circuits

Diagram	Notes
	<p>Circuit A is suitable for AC or DC applications, but if used with AC voltage, impedance of the load should be smaller than that of the CR circuit. Do not utilize for timer loads, as leakage current can cause faulty operations.</p>
	<p>Circuit B is suitable for AC or DC. If the load is a relay or solenoid, release times lengthen. Effective when connected to both contacts, power supply voltage across the load is 100 to 200 V.</p>

Varistor Circuit

Diagram	Notes
	<p>Effective for AC and DC applications.</p>
	<p>Circuit slightly delays release time. Effective when connected to both contacts, power supply voltage across the load is 100 to 200 V.</p>

In-Rush Current

The type of load and its in-rush current characteristics, together with switching frequency, can cause contact welding. For loads with in-rush current, measure the steady state current and in-rush current to determine the proper relay. Some typical types of loads and the in-rush current they create are summarized in Table 3.

Table 3. Typical Load Types and In-Rush Currents

Type of Load	In-Rush Current
Resistive load	Steady-state current
Motor load	5 to 10 times the steady-state current
Incandescent lamp load	10 to 15 times the steady-state current

Table 3. Typical Load Types and In-Rush Currents (Continued)

Type of Load	In-Rush Current
Mercury lamp load	Approximately 3 times the steady-state current
Sodium vapor lamp load	1 to 3 times the steady-state current
Capacitive load	20 to 40 times the steady-state current
Transformer load	5 to 15 times the steady-state current

Status Indicators

Figure 3 shows the status indicator LEDs on the cFP-RLY-423.

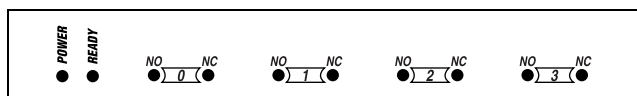
**Figure 3.** Status Indicators

After you insert the cFP-RLY-423 into a backplane and apply power to the network module, the green **POWER** indicator lights and the cFP-RLY-423 informs the network module of its presence. When the network module recognizes the cFP-RLY-423, it sends initial configuration information to the cFP-RLY-423. After the cFP-RLY-423 receives this initial information, the green **READY** indicator lights and the module is in normal operating mode.

In addition to the green **POWER** and **READY** indicators, each channel has two green output state indicators labeled NO and NC. These indicators show which terminal is connected to IC.

Isolation and Safety Guidelines



Caution Read the following information before attempting to connect the cFP-RLY-423 to any circuits that may contain hazardous voltages.

This section describes the isolation of the cFP-RLY-423 and its compliance with international safety standards. The field wiring connections are isolated from the backplane. The isolation is provided by the module, which has optical and galvanic isolation barriers designed and tested to protect against transient fault voltages of up to 2,300 V_{rms}. The cFP-RLY-423 provides *double insulation* (compliant with IEC 61010-1) for working voltages of

250 V_{rms}¹. Safety standards (such as those published by UL and IEC) require the use of double insulation between hazardous voltages and any human-accessible parts or circuits.

Never try to use any isolation product between human-accessible parts (such as DIN rails or monitoring stations) and circuits that can be at hazardous potentials under normal conditions, unless the product is specifically designed for such an application, as is the cFP-RLY-423.

Even though the cFP-RLY-423 is designed to handle applications with hazardous potentials, follow these guidelines to ensure a safe total system:

- The cFP-RLY-423 has a safety isolation barrier between the I/O channels and the inter-module communication bus. There is no isolation between channels unless otherwise noted. If any of the channels on a module are wired at a hazardous potential, make sure that all other devices or circuits connected to that module are properly insulated from human contact.
- Do *not* share the external supply voltages (the V and C terminals) with other devices (including other FieldPoint devices), unless those devices are isolated from human contact.
- You *must* connect the protective earth (PE) ground terminal on the cFP-BP-*x* backplane to the system safety ground. The backplane PE ground terminal has the following symbol stamped beside it: . Connect the backplane PE ground terminal to the system safety ground using 14 AWG (1.6 mm) wire with a ring lug. Use the 5/16 in. panhead screw shipped with the backplane to secure the ring lug to the backplane PE ground terminal.
- As with any hazardous voltage wiring, make sure that all wiring and connections meet applicable electrical codes and commonsense practices. Mount backplanes in an area, position, or cabinet that prevents accidental or unauthorized access to wiring that carries hazardous voltages.
- The isolation of the cFP-RLY-423 is certified as double-insulated for working voltages of 250 V_{rms}. Do *not* use the cFP-RLY-423 as the only isolating barrier between human contact and working voltages of more than 250 V_{rms}.

¹ *Working voltage* is defined as the signal voltage plus the common-mode voltage. *Common-mode voltage* is the voltage of the module with respect to ground.

- Operate the cFP-RLY-423 only at or below Pollution Degree 2. Pollution Degree 2 means that only nonconductive pollution occurs in most cases. Occasionally, however, a temporary conductivity caused by condensation must be expected.
- Do *not* operate FieldPoint products in an explosive atmosphere or where there may be flammable gases or fumes. If you need to operate FieldPoint products in such an environment, the FieldPoint products *must* be in a suitably rated enclosure.
- Operate the cFP-RLY-423 at or below Installation Category II. Installation Category II is for measurements performed on circuits directly connected to the electrical distribution system. This category refers to local-level distribution, such as that provided by a standard wall outlet.

Specifications

The following specifications are typical for the range -40 to 60 °C unless otherwise noted.

Relay Characteristics

Number of channels	4
Relay type	1 Form C (SPDT), nonlatching
Maximum switching capacity (resistive load)	
20 mVAC to 250 VAC	1.5 A at -40 to 45 °C 1.0 A at 45 to 55 °C 0.5 A at 55 to 60 °C
0 to 35 VDC	1.5 A at -40 to 45 °C 1.0 A at 45 to 55 °C 0.5 A at 55 to 60 °C
35 to 55 VDC	1 A at -40 to 55 °C 0.5 A at 55 to 60 °C
55 to 120 VDC	0.4 A
Minimum switching load	100 mA at 5 VDC
DC path resistance	
Initial	≤ 200 m Ω
End of life	≥ 1.0 Ω



Note DC path resistance typically remains low for the life of the relay. At the end of relay life, the path resistance rises rapidly above 1 Ω . Load ratings apply to relays used within the specification before the end of relay life.

Off-state leakage (120 VDC/250 VAC)

Frequency	Off-State Leakage
DC	0.12 μ A
50/60 Hz	8 μ A

Expected life

Mechanical 2×10^7 operations min
 Electrical..... 1×10^5 operations at rated resistive load

Maximum switching frequency

Mechanical 20 operations per second
 Electrical..... 1 operation per second at maximum load

Relay operate time <13 ms

Relay release time..... <13 ms

Relay bounce time <6 ms

Contact material..... Silver cadmium oxide

Physical

Indicators Green **POWER** and **READY** indicators, 8 green output state indicators

Weight..... 142 g (5.0 oz)

Power Requirements

Power from network module 1.2 W at 25 to 60 $^{\circ}$ C
 1.5 W at -40 to 25 $^{\circ}$ C

Isolation Voltage

Maximum isolation voltage	250 V _{rms} , Installation Category II
Channel-to-channel isolation	No isolation between channels
Transient overvoltage.....	2,300 V _{rms}

Environmental

FieldPoint modules are intended for indoor use only. For outdoor use, they must be mounted inside a sealed enclosure.

Operating temperature	-40 to 60 °C
Storage temperature	-55 to 85 °C
Humidity	10 to 85% RH, noncondensing
Maximum altitude.....	2,000 m; at higher altitudes the isolation voltage ratings must be lowered
Pollution Degree	2

Safety

This product is designed to meet the requirements of the following standards of safety for electrical equipment for measurement, control, and laboratory use:

- IEC 61010-1, EN 61010-1
- UL 3121-1, UL 61010C-1
- CAN/CSA C22.2 No. 1010.1

For UL, hazardous location, and other safety certifications, refer to the product label or to ni.com.

Electromagnetic Compatibility

CE, C-Tick, and FCC Part 15 (Class A) Compliant

Emissions.....	EN 55011 Class A at 10 m FCC Part 15A above 1 GHz
Immunity.....	EN 61326:1997 + A2:2001, Table 1



Note For EMC compliance, you *must* operate this device with shielded cabling.

CE Compliance

This product meets the essential requirements of applicable European Directives, as amended for CE marking, as follows:

Low-Voltage Directive (safety)..... 73/23/EEC

Electromagnetic Compatibility

Directive (EMC) 89/336/EEC



Note Refer to the Declaration of Conformity (DoC) for this product for any additional regulatory compliance information. To obtain the DoC for this product, click **Declarations of Conformity Information** at ni.com/hardref.nsf/.

Where to Go for Support

For more information about setting up the FieldPoint system, refer to these National Instruments documents:

- FieldPoint network module user manual
- Other FieldPoint I/O module operating instructions
- FieldPoint connector block operating instructions

Go to ni.com/support for the most current manuals, examples, and troubleshooting information.

For telephone support in the United States, create your service request at ni.com/support and follow the calling instructions or dial 512 795 8248. For telephone support outside the United States, contact your local branch office:

Australia 1800 300 800, Austria 43 0 662 45 79 90 0,
Belgium 32 0 2 757 00 20, Brazil 55 11 3262 3599,
Canada (Calgary) 403 274 9391,
Canada (Montreal) 514 288 5722,
Canada (Ottawa) 613 233 5949, Canada (Québec) 514 694 8521,
Canada (Toronto) 905 785 0085,
Canada (Vancouver) 514 685 7530, China 86 21 6555 7838,
Czech Republic 420 2 2423 5774, Denmark 45 45 76 26 00,
Finland 385 0 9 725 725 11, France 33 0 1 48 14 24 24,
Germany 49 0 89 741 31 30, Greece 30 2 10 42 96 427,
India 91 80 51190000, Israel 972 0 3 6393737,
Italy 39 02 413091, Japan 81 3 5472 2970,
Korea 82 02 3451 3400, Malaysia 603 9131 0918,
Mexico 001 800 010 0793, Netherlands 31 0 348 433 466,
New Zealand 0800 553 322, Norway 47 0 66 90 76 60,

Poland 48 0 22 3390 150, Portugal 351 210 311 210,
Russia 7 095 783 68 51, Singapore 65 6226 5886,
Slovenia 386 3 425 4200, South Africa 27 0 11 805 8197,
Spain 34 91 640 0085, Sweden 46 0 8 587 895 00,
Switzerland 41 56 200 51 51, Taiwan 886 2 2528 7227,
Thailand 662 992 7519, United Kingdom 44 0 1635 523545

FieldPoint™, National Instruments™, NI™, and ni.com™ are trademarks of National Instruments Corporation. Product and company names mentioned herein are trademarks or trade names of their respective companies. For patents covering National Instruments products, refer to the appropriate location: **Help»Patents** in your software, the `patents.txt` file on your CD, or `ni.com/patents`.

© 2003 National Instruments Corp. All rights reserved.



323605B-01

Jul03