

medlab

Three Lead ECG OEM board

EG01010

Technical Manual

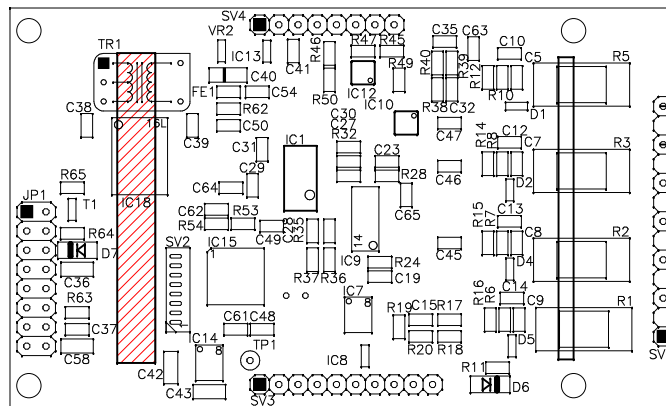

Copyright © Medlab 2008 - 2013

Version 1.02

Medlab GmbH

oemsales@medlab-gmbh.de

www.medlab-gmbh.de

Table of Contents

Mechanical Dimensions	4
Overview	4
Description of the Module and Connectors	5
Physical Units of Transmitted Data	5
Specifications	6
Connector Assignment	7
Compliance with IEC60601-2-27	8
Software Protocol Description	10
Serial Transmission	10
Serial Transmission Protocol	11
Commands accepted by the Module	12
PC Test Program	14
Regulatory Considerations	15
Document Revisions	15

Mechanical Dimensions of the Module

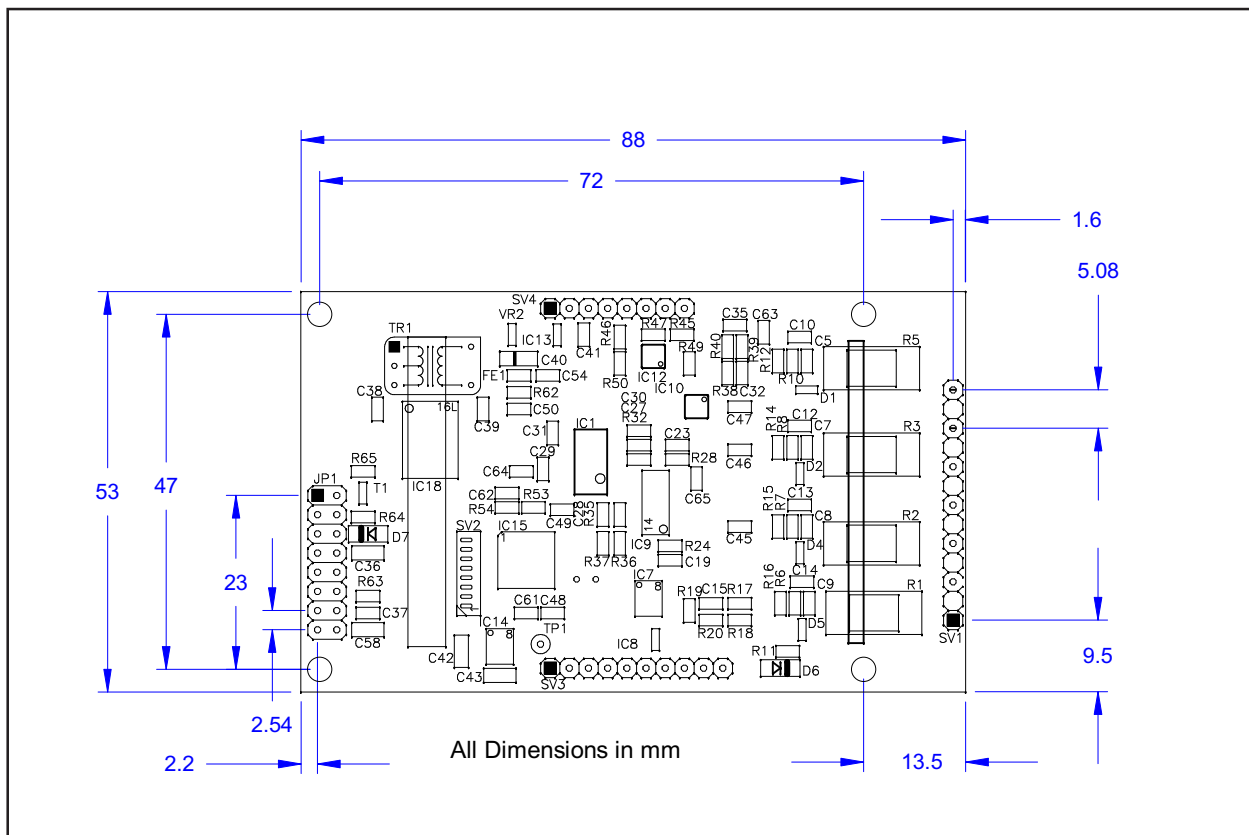

Mechanical drawing, top view of the module (1:1)

Overview

The scope of this document is the description and specification of Medlab's three lead ECG board EG01010. It should help anybody who is familiar with both programming and basic electronics to select the proper hardware and software version for his application as well as to help him integrate the board into his own electronic system.

The EG01010 measures one of three channels of ECG using a three lead cable. The isolated patient ground must not be connected to the mains ground. The EG01010 has full patient isolation on the board, that means that the input voltage of 5 volts has no galvanic contact to the patient. Furthermore, the module is defibrillation protected.

The isolation gap can be easily seen on the board: it is the area that is bridged only by the transformer 76250 and the couplers ADUM2402.

No connections to anything except the patient cable must be made on the patient cable input side of the module (see drawing on the next page).

With a three lead cable, the module can output the following channels: I or II or III. The isolated ground of the module is switched to the unused electrode in the respective setting, e.g. isolated ground is on the left leg electrode if the module is set to channel I, left hand electrode if module is set to channel II and right hand electrode if channel III is selected. Only one curve at a time can be measured, e.g. Einthoven I or II or III.

Description of the Module and Connectors

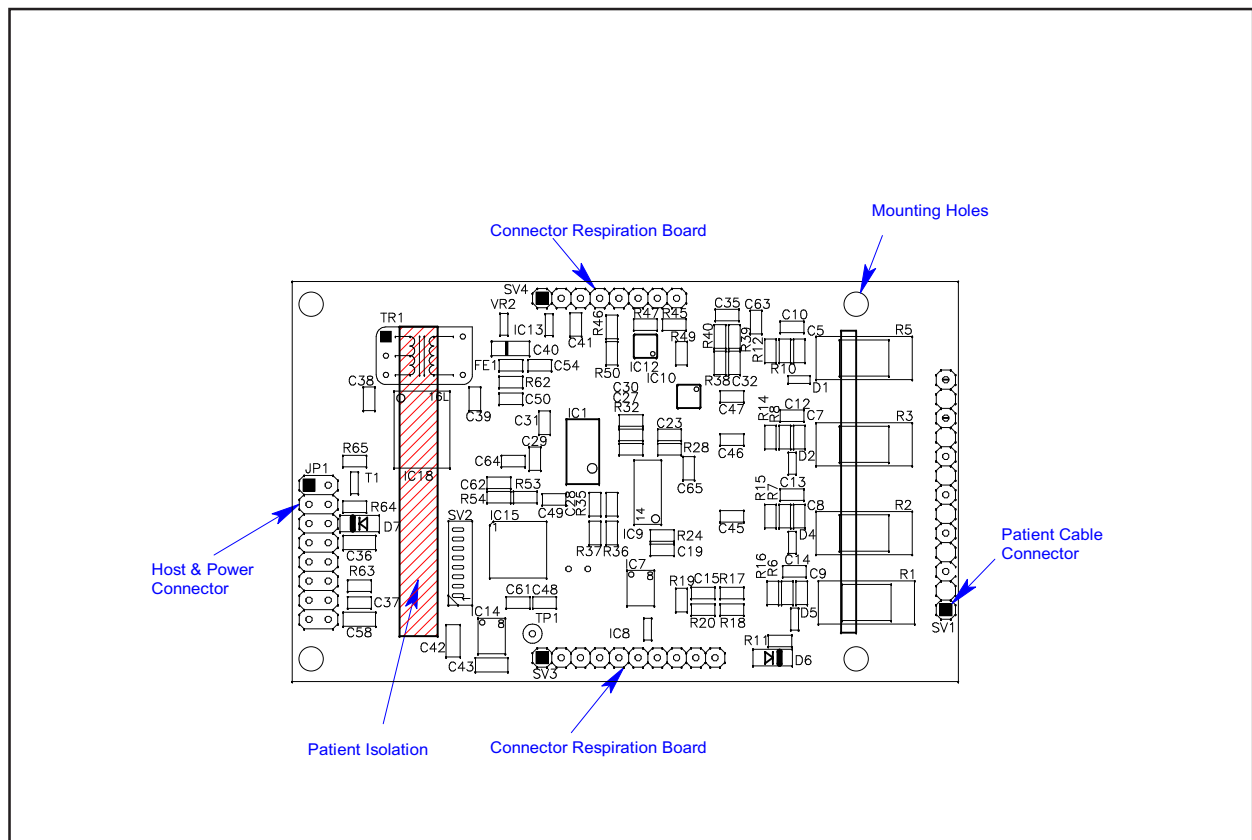

Description of connectors and areas of the module (1:1)

Physical Units of Transmitted Data

Scaling of ECGs is done normally in the unit "cm/mV" for the Y-axis and in "mm/sec" for the X-axis.

Respiration rate is transmitted in „rpm“ (respirations per minute).

Pulse rate is transmitted in „bpm“ (beats per minute).

Transmission speed for the wave is indicated in Hz (sec⁻¹).

ECG amplitudes are normally indicated in „cm/mV“. Since this is depending directly on the resolution of the screen the user is working with, the transmitted samples are not directly scaled in this unit, but fall into the range of 0-0xF7 (8 Bit samples, 0xF8 to 0xFF reserved for commands). It is within the responsibility of the user to scale the transmitted samples in a way that the waves displayed onto his screen fit to the usual scales used in medicine, 0.5, 1, 2 and 4 cm/mV. The amplification of the module in the different amplification stages is:

Stage 1	Stage 2	Stage 3
1mv = 32	1mV = 64	1mV = 128

Normal values for the trace speed are 12.5 mm/sec, 25 mm/sec and 50 mm/sec.

Technical Data (Specifications)

Mechanical data:	88 mm x 53 mm see page 4 for board drawing 4 layer PCB, thickness 1.5 mm
Maximum height:	12 mm
With respiration option:	25 mm
Attachment:	four M2.5 screws in the corners of the PCB
Weight:	32 g
Operating voltage:	5 Volt, +/- 10 %, 45 mA
Power consumption:	225 mW while measuring
Input:	Defibrillation protected
Patient Isolation:	CF, 4000 Volts RMS
Amplification:	Three levels, user selectable
Data transmission:	Three frequencies, user selectable
Filtering:	Integrated 50 Hz or 60 Hz notch filter
Amplifier frequency range:	0.05 to 70 Hz.
Pulse detection:	30 .. 248 bpm +/- 1%, +/- 1 Digit, 8 beat average
Respiration detection:	5 .. 99 rpm +/-3%, +/- 1 Digit, 8 samples average (option)
Output:	Asynchronous serial output with CMOS levels (0...5 V) Hardware pulse trigger output, CMOS levels (0...5 V) Both outputs fully isolated from patient
Protocol:	Standard bidirectional serial protocol, see description on following pages
Connector:	Connectors compatible to Medlab EG05000 five channel OEM board Optional connectors for Medlab 00731 respiration board

Connectors

(see attached drawing for location)

Header for host connection:

JP1:	1	Ground
	2	Ground
	3	Txd (RS232 level +/- 5Volt)
	4	Txd (TTL level)
	5	Rxd (RS232 level +/- 5Volt)
	6	Rxd (TTL level)
	7	Not connected
	8	Not connected
	9	Not connected
	10	Not connected
	11	Pulse Trigger output
	12	Pulse Trigger output
	13	Shutdown (VCC level on this pin powers down module)
	14	Shutdown (VCC level on this pin powers down module)
	15	VCC input
	16	VCC input

Note: The pulse trigger is a high active, rectangular signal with a pulse width of 33 ms. Delay to the R wave can be adjusted by a command.

Header for patient cable connection

SV1:	1	Unused
	2	SHIELD
	3	LL-IN
	4	RA-IN
	5	LA-IN
	6	SHIELD
	7	Unused

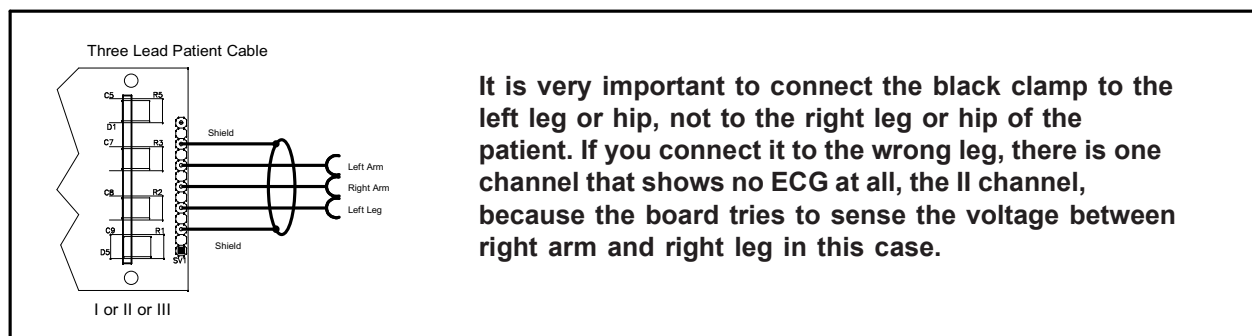

ECG cable connection

Remark:

For respiration measurement (optional respiration board needed), electrodes should be attached to chest and hip, not arm and leg.

Technical Description for TRF IEC 60601-2-27

When preparing a test report form (TRF) for proof of compliance of the user's medical product to IEC60601-2-27:2005, the following remarks / technical data will be helpful or needed:

Input Impedance:	> 10 MOhm
Common mode rejection ratio:	> 90 dB at 50 Hz or 60 Hz
Input Dynamic Range:	± 5 mV AC, ± 300 mV DC
Defibrillator Discharge Recovery:	<10 sec per IEC 601-2-27 <10 sec per AAMI EC13-1992
Leads-off sensing current:	Applied currents less than 150 nA

The following information references particular sections of IEC 601-2-27

Respiration (optional) Section 6.8.2.bb.1)

Applied currents less than 80 μ A @ 90 kHz square

Tall T-wave rejection. Section 6.8.2.bb.2)

T-wave of 1.2 mV amplitude will not affect heart rate determination.

Heart rate averaging. Section 6.8.2.bb.3)

TBD

Response to irregular rhythm. Section 6.8.2.bb.4)

A1) Ventricular bigeminy: the EG01010 counts both large and small QRS complexes to display a rate of 80 bpm.

A2) Slow alternating ventricular bigeminy: the EG01010 counts both large and small QRS complexes to display a rate of 60 bpm.

A3) Rapid alternating ventricular bigeminy: the EG01010 counts all QRS complexes to display a rate of 120 bpm.

A4) Bi-directional systoles: the EG01010 counts all QRS complexes to display a rate of 90 bpm.

Heart rate meter response time. Section 6.8.2.bb.5)

a) Change from 80 to 120 BPM: 4 sec

b) Change from 80 to 40 BPM: 7 sec

Time to alarm for tachycardia. Section 6.8.2.bb.6)

Waveform B1:	Amplitude	Time to alarm
	0,5 mV	1 sec
	1 mV	1 sec
	2 mV	1 sec
Waveform B2	Amplitude	Time to alarm
	1 mV	1 sec
	2 mV	1 sec
	4 mV	1 sec

Pacemaker pulse display capability (See IEC 601-2-27 clause 50.102.12)

The EG01010 is capable of displaying the ECG signal in the presence of pacemaker pulses with amplitudes of ± 2 mV to ± 700 mV and durations of 0.1 ms to 2.0 ms. An indication for the pacemaker pulse is provided.

Pacemaker pulse rejection (See IEC 601-2-27 clause 50.102.13)**Without over/undershoot:**

- a) For single (ventricular-only) pacemaker pulses alone, with 0.1 and 2.0 ms pulse-widths and ± 2 mV and ± 700 mV pulse-amplitudes, the EG01010 correctly displays heart rate as zero bpm (Asystole).
- b) For single (ventricular-only) pacemaker pulses with normally paced QRS-T, with 0.1 and 2.0 ms pulse-widths and ± 2 mV and ± 700 mV pulse-amplitudes, the EG01010 correctly displays heart rate of the QRS-T rhythm (60 bpm for the specified test waveform).
- c) For single (ventricular-only) pacemaker pulses with ineffectively paced QRS pattern, with 0.1 and 2.0 ms pulse-widths and ± 2 mV and ± 700 mV pulse-amplitudes, the EG01010 correctly displays heart rate of the underlying QRS-T rhythm (30 bpm).
- d) For atrial/ventricular pacemaker pulses alone, with 0.1 and 2.0 ms pulse-widths and ± 2 mV and ± 700 mV pulse-amplitudes, the EG01010 correctly displays heart rate of zero bpm (Asystole).
- e) For atrial/ventricular pacemaker pulses with normally paced QRS-T, with 0.1 and 2.0 ms pulse-widths and ± 2 mV and ± 700 mV pulse-amplitudes, the EG01010 correctly displays heart rate of the QRS-T rhythm (60 bpm).
- f) For atrial/ventricular pacemaker pulses with ineffectively paced QRS pattern, with 0.1 and 2.0 ms pulse-widths and ± 2 mV and ± 700 mV pulse-amplitudes, the EG01010 correctly displays heart rate of the underlying QRS-T rhythm (30 bpm).

With over/undershoot:

- a) For single (ventricular-only) pacemaker pulses alone, with 0.1 and 2.0 ms pulse-widths and ± 2 mV and ± 700 mV pulse-amplitudes, the EG01010 correctly displays heart rate of zero bpm (Asystole).
- b) For single (ventricular-only) pacemaker pulses with normally paced QRS-T, with 0.1 and 2.0 ms pulse-widths and ± 2 mV and ± 700 mV pulse-amplitudes, the EG01010 correctly displays heart rate of the QRS-T rhythm (60 bpm).
- c) For single (ventricular-only) pacemaker pulses with ineffectively paced QRS pattern, with 0.1 and 2.0 ms pulse-widths and ± 2 mV and ± 700 mV pulse-amplitudes, the EG01010 correctly displays heart rate of the underlying QRS-T rhythm (30 bpm).
- d) For atrial/ventricular pacemaker pulses alone, with 0.1 and 2.0 ms pulse-widths and ± 2 mV and ± 700 mV pulse-amplitudes, the EG01010 correctly displays heart rate of zero bpm (Asystole).

Serial Transmission

The normal connection to the board is done via serial, asynchronous communication at 9600 baud, 8 data bits, no parity bit and one stop bit. Both CMOS and RS232 (+/- 5 Volt level) voltage levels are available.

This protocol is token oriented. Special marker bytes that are not present in the normal data stream mark the meaning of the following byte.

The RS232 voltage levels are helpful during evaluation of the board, which can be done using an ordinary PC and a special software. The connection in the customer's final system could be done through 0V/5V levels, which saves parts on the customer's side of the data stream.

Connector JP1 is compatible with the interface connector on Medlab's EG05000 five channel ECG OEM board. Therefore, test cables that have been built for this board can also be used for the EG01010 board.

The EG01010 sends a continuous data stream and receives commands. Commands are one byte characters, some of them have an additional parameter, others just toggle an internal switch in the EG01010 module.

The neutral line of the ECG always lies at 128, the module transmits unsigned byte data. While a lead off condition is active, a pulse value of 0 and a neutral line of 128 is transmitted.

The module powers up with amplification set to level 0 and speed set to level 1, which means lowest amplification stage and transmission of 100 sample points per second. Simulation mode is off at power up, the notch filter is set to 50 Hz and monitoring mode is selected.

For details, please see the protocol description on the following pages.

Serial Transmission Protocol

All data is transmitted at 9600 baud, 8 bits, 1 stop bit, no parity. Each time a pulse is detected by the board's internal algorithm, a block with a new, averaged pulse rate is transmitted. The pulse detector is of high quality, and the point in time where the pulse marker (0xFA) is transmitted can be used for triggering applications that require to synchronize other devices to a patient's R-wave.

The ECG wave sample points are transmitted continuously with 50, 100 or 300 bytes per second, according to the user's last command. The curve sample points lie between 0 and 246, with the neutral line of the ECG being at 128.

Values that are higher than 246 (0xF6) are used for marking the following byte as a new data values according to the following definition:

Marker byte	Meaning of following byte(s)	Commands accepted by the module
0xF8	wave sample points follow	"N" normal operation mode "M" switch to simulation mode
0xF9	Respiration rate follows (optional respiration board needs to be present)	"S" "0" send ECG trace with 300 Hz "S" "1" send ECG trace with 100 Hz "S" "2" send ECG trace with 50 Hz
0xFA	Pulse value follows	"A" "0" amplification stage 0 "A" "1" amplification stage 1 "A" "2" amplification stage 2
0xFB	Info byte follows	"G" "0" channel III "G" "1" channel II "G" "2" channel I
0x11	The only info byte defined is 0x11, "LEAD OFF" Others may be added in the future	"D" "0" show ECG curve "D" "1" show respiration curve
		"5" turn on 50 Hz notch filter "6" turn on 60 Hz notch filter "C" calibrate, send 1mV pulse
		"T" "0" Pulse trigger 15 ms after R "T" "1" Pulse trigger 50 ms after R "T" "2" Pulse trigger 100 ms after R "T" "9" Pulse trigger middle between R
		"P" "0" Pacemaker detection off "P" "1" Pacemaker detection on

Example transmitted data stream :

Wave Marker	Wave Samples	Pulse 120	Wave Marker	Wave Samples
0xF8	0x20 0x23 0x25	0xFA 0x78	0xF8	0x25 0x25 0x26



Commands accepted by the Module

All commands have a one or two byte structure. They are also sent to the module with 9600 baud. The commands are sent in ASCII format.

Basic Bandwidth of ECG amplifier (Diagnostic or Monitoring mode):

- „F“ Parameter: "0" or "1"
- „0“ bandwidth of the amplifier DC-80 Hz Diagnostic mode (bear in mind mains filter setting)
- „1“ bandwidth of the amplifier 0.67-40 Hz Monitoring mode (reset value)
- „S“ extra strong filter, lower edge frequency 2 Hz

Transmission frequency of the waveform packet:

- „S“ Parameter: "0", "1", "2" (0x53 0x31 for example for „S1“)
- „0“ send waveform packets 300 times per second
- „1“ send waveform packets 100 times per second (reset value)
- „2“ send waveform packets 50 times per second

Amplification of the waveforms

- „A“ Parameter: "0", "1", "2" or "3" (0x41 0x31 for example for „A1“)
- „0“ Amplification stage 1 (lowest amplification, should be scaled to 0.5 cm/mV)
- „1“ Amplification stage 2
- „2“ Amplification stage 3 (highest amplification, should be scaled to 2 cm/mV)

Each amplification stage has **double the sensitivity** of the previous stage

Channel selection (1 wave channel can be selected)

- „G“ Parameter: "0", "1" or "2" (for Einthoven III, II or I selection)

Filtering of the waveforms for 50 and 60 Hz line frequency:

- „5“ 50Hz Filter on
- „6“ 60 Hz Filter on

Selecting the transmitted waveform:

- „D“ Parameter: „0“ or „1“ (0x44 0x30 for example for „D0“)
- „0“ Show ECG trace (reset value)
- „1“ Show respiration waveform (optional respiration board needed)

Calibration mode (1mV rectangle transmitted for 250 samples):

- „C“ output 250 samples of 1 mV rectangular waves, then go back to normal mode

Simulated data outputs (useful for testing or exhibitions):

- „M“ use simulated output waves and values
- „N“ use real input for data transmission (reset value)

Set delay of the pulse trigger signal (active high, 33 ms duration):

- „T“ Parameter: „0“ , „1“ , „2“ , or „9“
- „0“ Delay of the pulse trigger signal 15 ms (reset value)
- „1“ Delay of the pulse trigger signal 50 ms
- „2“ Delay of the pulse trigger signal 100 ms
- „9“ The signal triggers in the middle between R waves

Pacemaker detection on or off:

- „P“ Parameter: „0“ , „1“
- „0“ Pacemaker detection off
- „1“ Pacemaker detection on (reset value)

Test Program

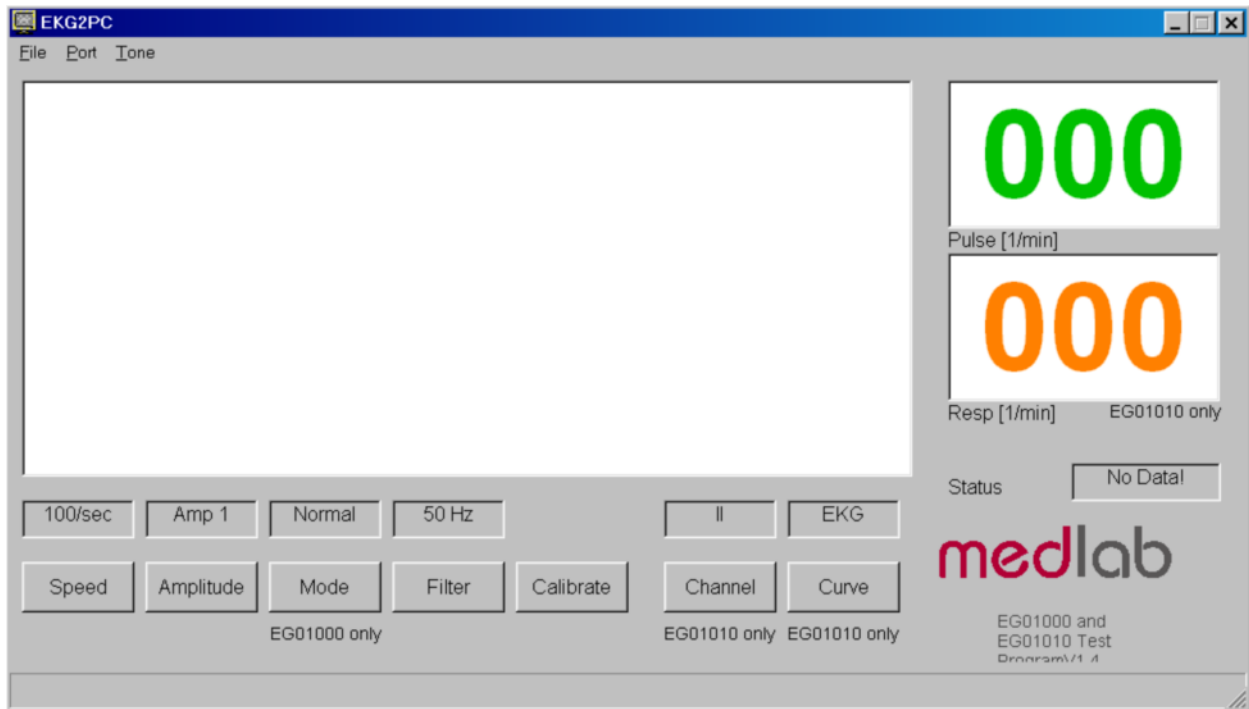

For easy integration of the module into medical systems, a test software has been made available. The EG01010 can be connected directly to a PC, the received data is shown on the screen.

To run the program, connect the EG01010 board to the serial port of a PC. If the PC has no serial port, please use a USB to RS232 adapter and install the driver of this adapter first and make sure to create a virtual serial port. Connect the power input to a 5 volts DC source. Then start the program on your PC and select the serial port number in the "Port" menu.

Commands can be sent to the board by pressing the command buttons in the application. Since the same software can be used for the one channel EG01000 and the three channel EG01010 board, some buttons have no function when used with the EG01010.

The software is available free of charge on: www.medlab.eu, on the page describing the EG01010. The software is written in Visual Basic 6 and the source code is also included in the download package.

Regulatory Considerations

The device that has been described in this document is not a final medical product. That means that it cannot be used as a standalone unit to use it on patients.

Therefore, the EG01010 has not been - and also cannot be - CE-marked. The customer has to undertake the procedure of CE-marking the final product that contains the module. However, several products on the market have successfully passed this certification.

The module complies with the following standards, as far as applicable:

IEC60601-1

IEC60601-1-2

IEC60601-1-4

IEC60601-2-27:2005

ANSI/AAMI EC13:2002

ANSI/AAMI EC57:1998

During testing and certification of a product, also the user manual of the final product needs to be certified. The user manual has to contain certain technical data and warnings to the end users. We can support customers by supplying material for the manual that has been used during the certification process of Medlab's devices.

Document Revisions

Rev. 1.00:	Initial version
Rev. 1.01:	Corrected typing errors; changed manufacturer address
Rev. 1.02:	Corrected some values on p. 12

Medlab medizinische Diagnosegeräte GmbH
Helmholtzstrasse 1
76297 Stutensee (Karlsruhe)
Germany
Tel. +49(0)7244 741100
oemsales@medlab-gmbh.de
www.medlab-gmbh.de
