

**SIDE-POWER**  
Thruster Systems

**SEP170/250TC IP**  
**Ignition Protected**  
**thruster assembly**

Keep this  
manual onboard !

## Installation and user manual



**SLEIPNER MOTOR AS**

P.O. Box 519  
N-1612 Fredrikstad  
Norway  
Tel: +47 69 30 00 60  
Fax: +47 69 30 00 70

[www.side-power.com](http://www.side-power.com)  
[sidepower@sleipner.no](mailto:sidepower@sleipner.no)



Made in Norway

## Contents

Technical specifications.....	2
Planning & important precautions.....	3
Stern thruster installation considerations.....	3
Bolt on installation .....	4
Mould on installation .....	5
Gearhouse and motorbracket.....	6
Oil tank & propellers .....	7
Electromotor IP assembly.....	8
Electrical installation .....	9
Control panel and control-leads.....	10
Visual wiring diagram .....	11
Technical wiring diagram .....	12
Electrical installation of stern thruster systems .....	12
Checklist.....	13
Important user precautions.....	14
How to use Sidepower thrusters.....	15
Maintenance.....	16
Troubleshooting.....	17
Warranty statement .....	18
Parts list.....	19
Service centres .....	20

## DECLARATION OF CONFORMITY



We, Sleipner Motor AS  
 P.O. Box 519  
 N-1612 Fredrikstad, Norway  
 declare that this product with accompanying  
 standard remote control systems complies with the  
 essential health and safety requirements according  
 to the Directive 89/336/EEC of 23 May 1989  
 amended by 92/31/EEC and 93/68/EEC.

## Technical specifications

- Motor:** Custom made reversible DC-motor.
- Gearhouse:** Seawater resistant bronze. Angular contact ball bearing at propellershaft and combination of ball bearing and needle bearing at driveshaft.
- Motor bracket:** Seawaterresistant aluminium.
- Ignition protection:** Conforms to ISO 8846
- Propeller:** Symmetrical 4 blade kaplan propellers, fibreglass reinforced composite.
- Batteries:** Minimum recommended battery capacity (cold crank capacity by DIN standard)  
 SEP 170/250 24V : 500 CCA DIN/950 CCA SAE
- Max. use:** Up to continuous run time depending on load. Remaining run time shown on control panel.
- Safety:** Electronic time-lapse device protects against sudden change of drive direction. Electric thermal cut-off switch in electromotor protects against overheating (auto reset when electromotor cools down).  
  
 Flexible coupling between electro-motor and driveshaft protects electromotor and gearsystem if propeller gets jammed.  
  
 PJC panel shuts of automatically 5 minutes after last use (factory default). This interval can be adjusted in 5 min steps up to 60 minutes or turned off completly. The PPC Speed Control unit wil turn off motor power each time main solenoids is activated. This removes any possibility for solenoid lock in. Any fault in the main solenoids will give feed back to the panel and turn off power to the electric motor.

Measurements ref. mm / inch	<b>SEP170/250TC IP</b>
<b>A</b>	390mm / 15.4"
<b>B</b>	340mm / 13.4"
<b>C</b>	250mm / 9.8"
<b>D</b>	350mm / 13.8"
<b>E</b>	ø300mm / 11.8"
<b>F</b>	ø200mm / 7.84"
<b>G</b>	6x ø10.5mm / 0.41"
<b>H</b>	ø129mm / 5.08"
<b>Inside tunnel dia.</b>	250mm / 9.8"
<b>Max. stern thickness</b>	105mm/4.1"
<b>Motor output</b>	8kW / 10.7HP
<b>Voltage</b>	24 Volt

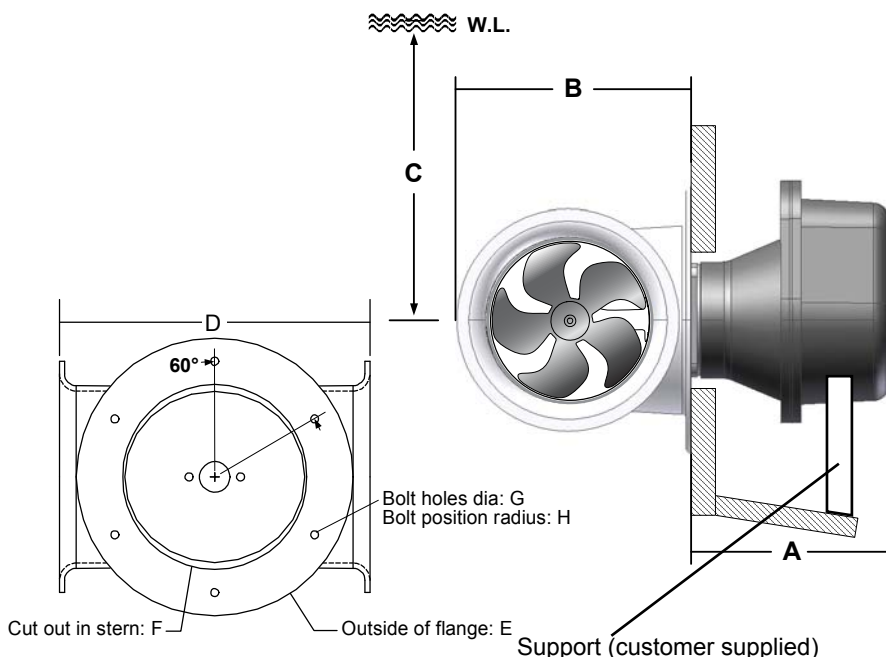

## Planning and important precautions

**Prior to installation, it is important that the installer reads this guide to ensure necessary acquaintance with this product.**

- ⌚ If the height in the room you are installing the Sidepower is limited, the Sidepower can be installed horizontally or at any angle in between.
  - If the electro motor is positioned more than 30° off vertical, it must be supported separately.
  - The electromotor must be handled carefully. Do not lift it by the internal connections/main terminals or put it down on the driveshaft.
  - Beware to keep installation within advised measurements. No part of the propeller or gearhouse must be outside the tunnel.
- ⌚ The electromotor, its components, contacts / plugs or other joints in the control cables must be mounted so that they will keep dry at all times.
- ⌚ We advice to paint the gearhouse and propellers with antifouling. PS! Do not paint the anodes, sealings or propellershafts.
- ⌚ Do not finish the inside of the tunnel with a layer of gelcoat / topcoat or similar. It is only room for a thin layer of primer and two layers of anti-fouling between the tunnel and the props.
- ⌚ With the boat on land, only run the thruster for a fraction of a second, as without resistance it will accelerate very fast to a damaging rpm. Also, while the thruster is in air, make sure that the propellers have come to a complete stop before performing a directions change of the thruster, as it might cause damage to the thruster.
- ⌚ The PPC Power control unit should be installed in a dry, ventilated place - cable connections facing down. Mount unit with battery positive cable branching out at unit terminal, not at thruster motor. Allow free space at min 200mm over and min 100mm in front and at sides. Take into consideration that a 5 m multicable shall be plugged in between thruster motor and PPC unit.
- ⌚ This manual is intended to support educated/experienced staff and is therefore not sufficient in all details for the correct installation.
- ⌚ Do not store items close to the thruster motor as it gets hot as well as any loose items near the thruster motor can cause problems with electrical wiring coming loose and short-circuiting.
- ⌚ When installed in boats approved or classified according to international or special national rules, the installer is responsible for following the demands in accordance with these regulations / classification rules. The instructions in this guide can not be guaranteed to comply with all different regulations/classification rules.
- ⌚ These instructions are only general instruction. If you are not skilled to do this work, please contact professional installers for assistance.

**NB! Faulty installation of the tunnel, thruster, PPC Power Control unit or panel will render all warranty given by Sleipner Motor AS void.**

## Stern thruster installation considerations

To achieve maximum effect, reliability and durability from your Sidepower stern thruster, a correct installation is very important.

Please follow the instructions carefully, and make sure that all checkpoints are carefully controlled.

### **Additional considerations for positioning of the stern thruster**

- ⌚ Make sure that the stern-tunnel does not disturb the waterflow under the hull
- ⌚ Ensure that when installed the thruster does not foul existing equipment inside the boat like steering links etc.
- ⌚ Make sure that the water flow from the thruster are not interferred to much by sterndrives, trimtabs etc. as this will reduce the thrust considerably.
- ⌚ It is possible to mount the tunnel off the boat's centre line if necessary.
- ⌚ If the stern thickness is to much for the thruster in question you can easily remove hull material in the necessary area to fit the thruster. You only have to reduce the stern thickness down to the max. thickness measurement in the drawing.

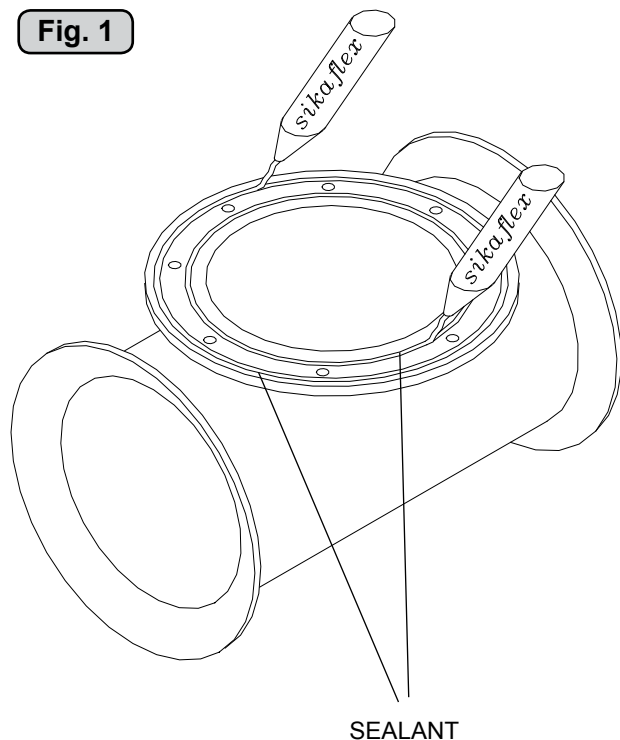
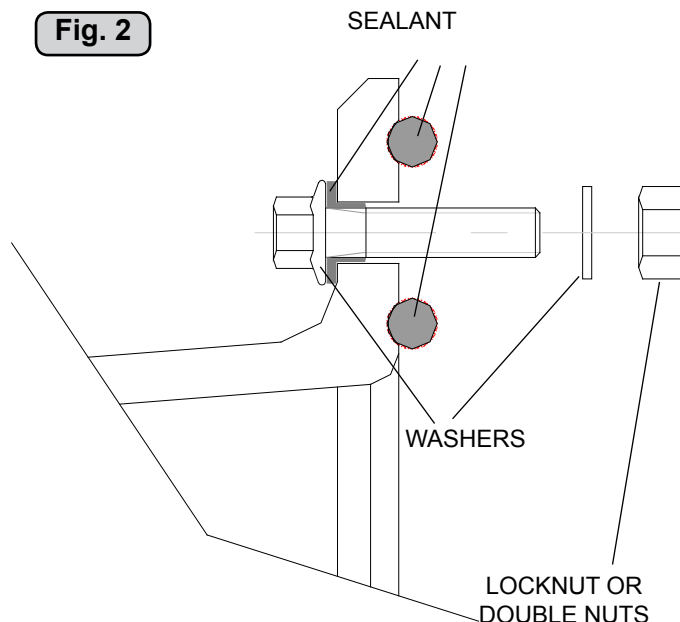
**Fig. 1****Fig. 2**

### Bolt on installation of the stern tunnel

1. Make sure that there are enough space both inside and outside the transom of the boat.
2. Once the place for the installation has been decided, hold the tunnel in place in the horizontal position and mark the bolt holes. Remove the tunnel and it is then possible to calculate and mark the centre.
3. It is important that the tunnel flange sits flush on the transom. If this is not so, then the area on the transom will have to be flattened to ensure a snug fit.  
PS ! Take care with grinders as it is very easy to remove too much in fibreglass  
At this time, cut out the centre hole and the transom to the same internal diameter as the tunnel flange and drill the bolt holes. Before bolting on the stern tunnel, the prepared area must be sealed with a gelcoat or similar to ensure there is no water ingress into the hull.
4. Before fitting the tunnel to the transom, fit the lower gear leg to the tunnel as described on page 6.
5. When fitting the tunnel, ensure that there is ample sealant (Sikaflex or similar) in the sealing tracks of the tunnel flange and around the bolts to make a water tight fitting (Fig. 1/2). Bolts, washers and nuts are not included as they will vary depending on the transom thickness We recommend A4 stainless with A4 lock nuts and A4 washers of a large diameter on both outside and inside.  
Bolts diameter:  $\varnothing$  10mm or 3/8" stainless steel
6. Refer to the installation manual for the recommended thruster fitting.

**If a bow thruster is also installed, we strongly advise to use separate battery banks for the two thrusters to avoid extreme voltage drop if both thrusters are to be used at the same time. Refer to the thruster manuals for advised battery capacity and cable sizes for each thruster. Also ensure that you do not have direct connections of both + and - if you have built together controls for both thrusters to avoid current leakage between separate battery banks. If you are installing the standard Sidepower dual joystick panel this is already secured.**

**Fig. 1**

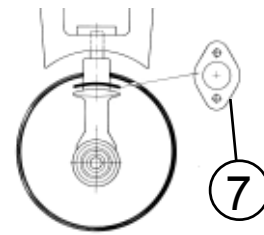

**Fig. 2**

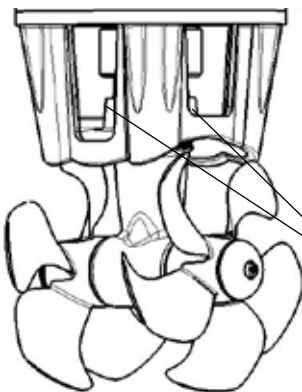

**Bolt tightening forces:**

Bolts (2x) holding gearhouse to bracket:  
33 Nm (24 lb/ft)

**Fig. 3**

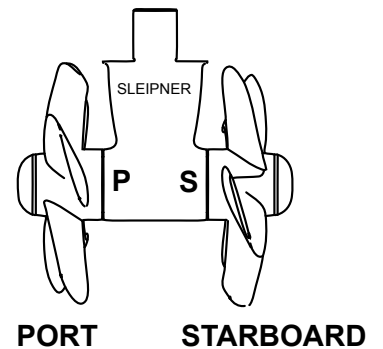

### Fitting gearhouse and motor bracket

1. Try the lower-unit in the tunnel (remove the anodes) first by using the gasket inside the tunnel. Try on the propellers to make sure it is centred in the tunnel and turn freely with the same clearance from each blade to the tunnel (Fig. 1).

The gearleg must be fitted with the end marked P facing port and the end marked S facing starboard (Fig. 3) for the thrust direction to correspond with the control panel. If there is no visible P or S marks, fit the gearleg with the "SLEIPNER"-casting towards the stern/back of the boat.

2. Apply a thin layer of sealant on both sides of the gasket (7) and place it carefully on the gearhouse, making sure no sealant gets into the bolt holes on the gearhouse (Fig 1).
3. Push the gearhouse through the main hole in the tunnel and push the gearhouse and motor-bracket gently together.
4. Fit the enclosed sealing washers to the bolts and screw the lower unit and the motor bracket together with the two provided bolts. Tighten with 33 Nm / 24 lb/ft (Fig. 2).

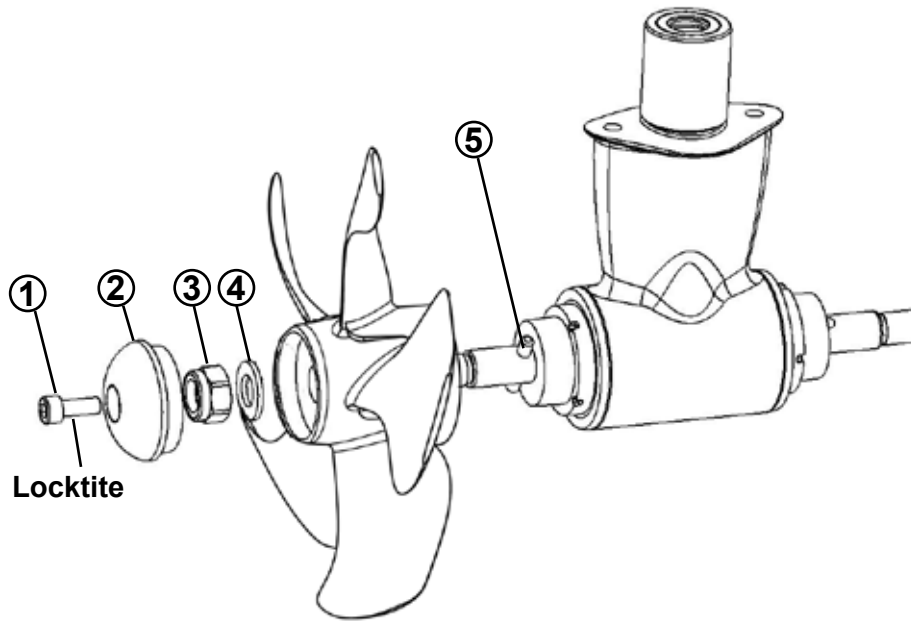

### Fitting propellers

1. Push the propeller onto the shaft, carefully rotate the propeller until the drive pin aligns and moves into the slot/groove in the propeller hub. There should be almost no gap (approximately 1mm) between the propeller hub and the gear house.
2. Place the washer (4) on the propeller shaft and then tighten the lock-nut (3) on the propeller shaft.
3. Place the anode (2) in its designated position and tighten the anodes holding screw (1). Apply a thread glue (Locktite or similar) to ensure that the anodes holding screw does not un-screw itself from the propellers rotation.
4. Fit the propellers to the shafts with the LH marked propeller on the port side and the RH marked propeller on the starboard side. Turn them to again make sure they move freely and as much in the centre of the tunnel as you have managed.

#### Parts description:

- 1: Screw for anode
- 2: Anode
- 3: Propeller lock nut
- 4: Washer
- 5: Drive pin for propeller

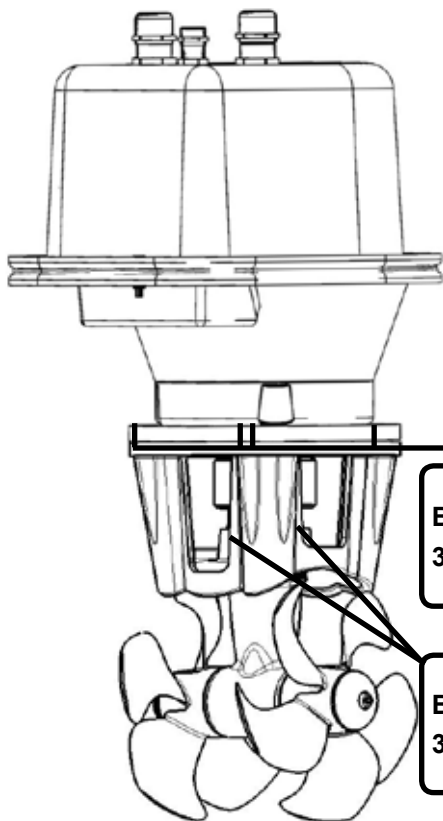
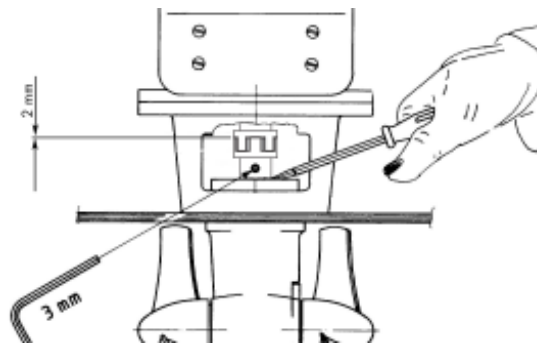

Fig. 2

**Bolt tightening force (4x):  
33 Nm (24 lb/ft)**

**Bolt tightening force (2x):  
33 Nm (24,4 lb/ft)**

Fig. 1



### Fitting the electromotor IP assembly

1. Remove the 4 bolts in the motorbracket.
2. Insert the lower part of the flexible coupling and the red plastic ring on the gear shaft. Place the motor (include the upper part of the flexible coupling) on the motor bracket. Fasten the motor to the bracket with the 4 bolts and tighten them. Lift the lower part of the flexible coupling together with the plastic ring into the upper part of the flexible coupling. The plastic ring must be in its correct position in the upper part, fully inserted, but not compressed against it (2mm). Secure the lower part of the coupling in its new position by tightening the set-screw.
3. If you are installing the thruster in an angle of more than 45 deg. off a vertical position, the electromotor needs a separate/additional support. See illustration in the measurements drawings.
4. Check the system by turning the propeller, it will be a little hard to turn (because of the gear reduction and the motor), but you should be able to turn it by hand.

### Final gearleg assembly

**NB !** Paint the gearhouse and propeller with antifouling for propellers to prevent growth of barnacles or similar which would reduce the performance dramatically. Do not paint the propeller shaft, the anodes or the end face of the gearhouse.

**Fig. 1**

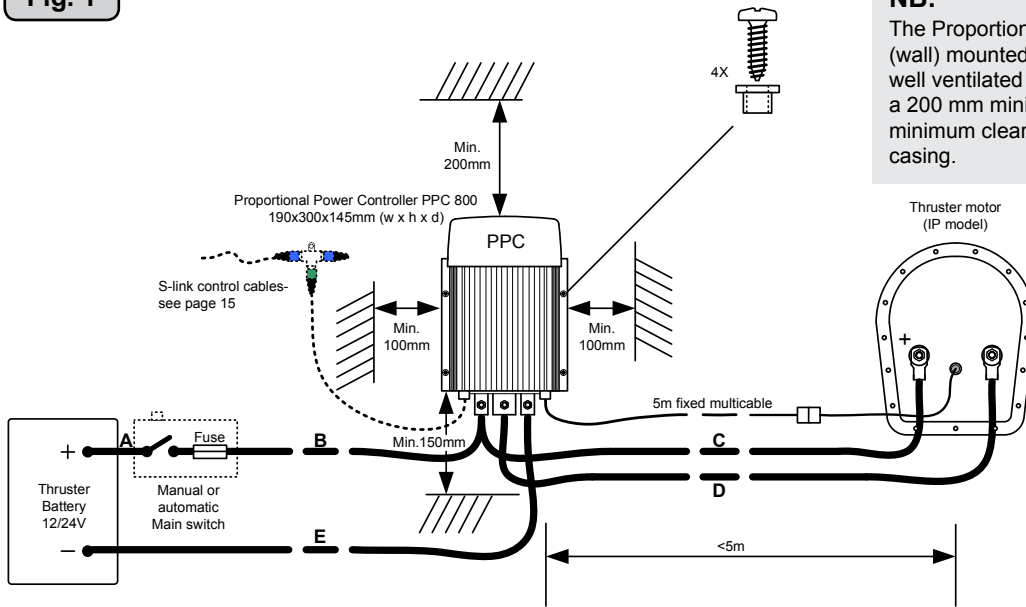

**NB:**

The Proportional Power Controller is a bulkhead (wall) mounted unit and must be installed in a dry and well ventilated compartment. The unit also requires a 200 mm minimum head clearance and a 100 mm minimum clearance surrounding its remaining outer casing.

**Fig. 2**

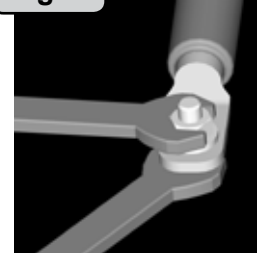

Table for selection of main cable, battery, fuse and main-switch sizes.			up to 7m total + & -		7 - 14m total + & -		14 - 21m total + & -		21 - 28m total + & -		28 - 35m total + & -		36 - 45m total + & -	
Model	Voltage	Current draw	Min. Cable dimension	Min. Battery CCA by DIN	Min. Cable dimension	Min. Battery CCA by Din	Min. Cable dimension	Min. Battery CCA by DIN	Min. Cable dimension	Min. Battery CCA by Din	Min. Cable dimension	Min. Battery CCA by DIN	Min. Cable dimension	Min. Battery CCA by Din
SEP170250TC	24V	550A	50mm <sup>2</sup> O	550 CCA DIN 1045 CCA SAE	70mm <sup>2</sup> OO+	550 CCA DIN 1045 CCA SAE	70mm <sup>2</sup> OO+	550 CCA DIN 1045 CCA SAE	90mm <sup>2</sup> OOO+	600 CCA DIN 1140 CCA SAE	100mm <sup>2</sup> OOOO	600 CCA DIN 1140 CCA SAE	120 mm <sup>2</sup> OOOO+	600 CCA DIN 1140 CCA SAE

**Electrical installation**

- Explanation of electrical table
  - All cable lengths are the total of A+B+C+D+E in Fig. 1.
  - Battery size is stated as minimum cold crank capacity, not Ah.
  - Use slow fuse rated to hold stated Amp-Draw for min. 5 minutes.
- It is important that you use a good cable size and batteries with a high cranking capacity to feed the thruster, because it is the actual voltage at the motor while running the thruster that decides the output rpm of the motor and thereby the actual thrust. Please see the list below for advised min. sizes of cables and batteries. You can of course use larger cables for even better results.
- A main switch that can take the load without noticeable voltage drop must be installed in the main positive lead so the power for the thruster can be turned off independent of the rest when not on board or in emergencies. This should be placed in an easy accessible place and the boats instructions should inform that this should be turned off like the boat's other main switches.
- We also advice to install a fuse in the positive lead for protection against short circuiting of the main cables. This fuse should be of a adequate quality which normally means that it is physically large as these have less voltage drop than the simple / small ones. It should be of the slow type and sized to take the amperage draw for at least 5 minutes.
- It is highly recommended to install a **Sidepower Automatic Main Switch 897712 (12V) eller 897724 (24V)**. **The AMS will be activated when the panel is turned on, contains an automatic short circuit fuse and a manual emergency stop. The AMS will also provide feedback to the panel regarding evt. faults.**
- The cable ends must be fitted with terminals and these must be well isolated against contact with anything but the proper connection point.
- Terminals must be properly tightened. Secure/hold inner nut when tightening (Fig. 2). Tighten  $\varnothing 10\text{mm}$  / 3/8" bolt with 15 Nm/11lb/ft.

**NB! Very important to check the following with mainswitch in off position:**

After all electrical connections have been completed check with an ohm meter that there is no electrical connection between electro motor flange and positive terminal on the motor and between the electro motor flange and the negative (A1) terminal on the motor. If you feel unsure on how to perform this check, contact skilled personnel for guidance.



### Control panel installation:

- You can install as many panels as you wish by using optional Side-Power S-link T-connectors  
If two or more panels are operated at the same time in opposite directions, the thruster will stop.  
When two or more panels is operated in the same direction, the thruster output will be determined by the panel giving the largest signal.
- When using original Sidepower equipment it is all "plug & go".
- The mechanical installation of the panel is described in the manual following the panel.
- The thruster control panel should be placed in a position were it is easy to use, and it is very common to use the thruster at the same time as your gear/throttle lever so it is normally a user friendly solution to be able to access these with one hand for each control.

# Wiring diagram

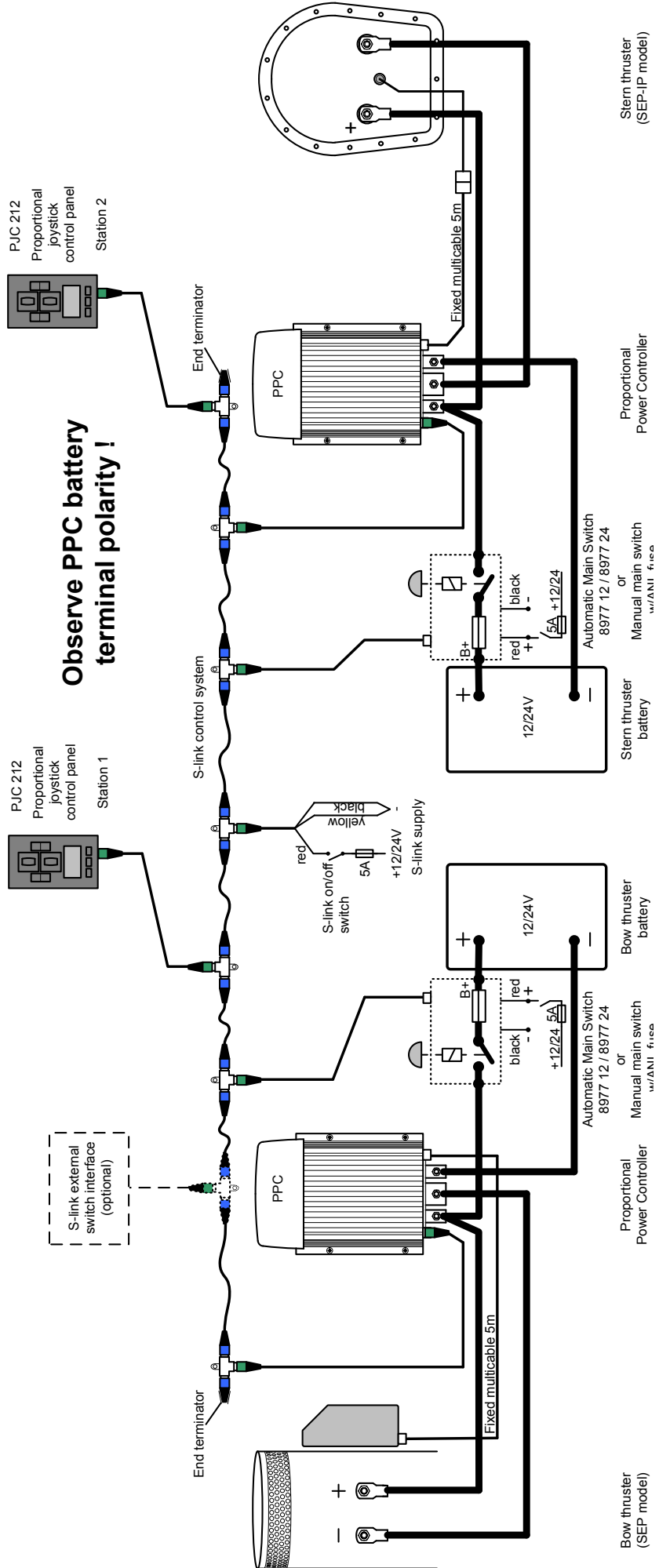

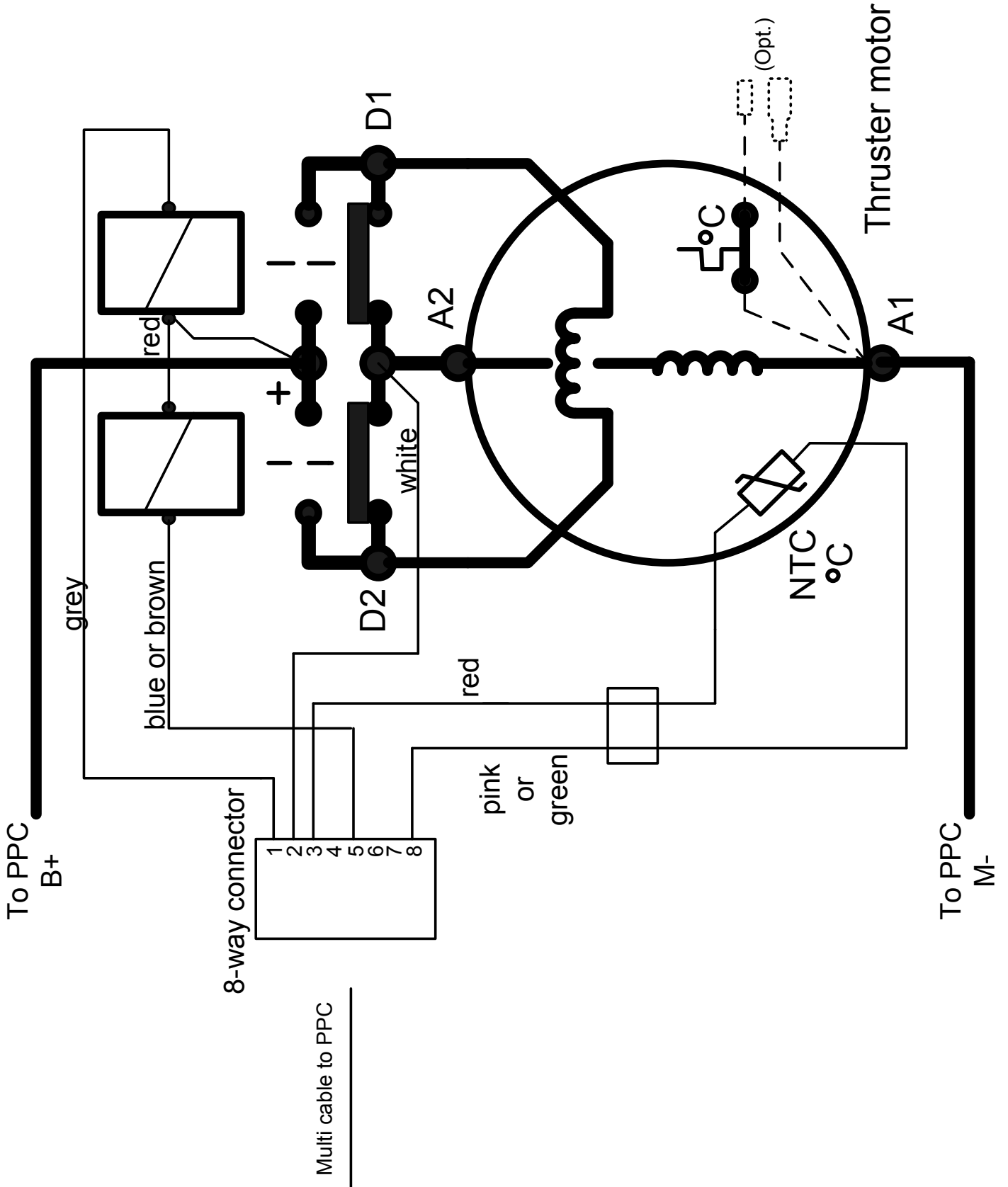

## Checklist

- Propellers is fastened correctly to the shaft.
- Propellers turns freely in tunnel.
- The anodes holding screw is tightened well with thread glue.
- Anti-fouling have been applied to the gearhouse and propellers but NOT on the anodes or the gearhouse lid where the propellers is fastened.
- The brush springs are fitted correctly on the brushes in the electro-motor (check through the grid around the top end of the motor).
- Correct drive direction as per control panel.
- All electrical connections are clean, dry and tight, and the correct cable, fuse and main switch sizes have been used.
- With a ohm meter check that there is no electrical connection between electromotor body and positive terminal on the motor and between the electromotor body and the negative (A1) terminal on the motor.
- The bolts holding the gearhouse and motorbracket together are tightened correctly.
- The bolts holding the electromotor to its bracket are tightened correctly.
- The 4 main cables connected to 3 terminals on PPC is placed correctly and properly fixed to avoid mecanical stress on the terminals

**Very important for IP protection:**

- The main power cables have securely been connected as described.
- The control lead ends out of the explosive area and has been properly fitted and secured against damage.

*The thruster has been installed as per the instructions in this manual and all points in checklist above have been controlled.*

Signed: ..... Date: .....

**Extra pre-delivery tests by installer / yard who does not use other quality control systems !**

Thruster type: ..... Voltage: .....

Serial number: .....

Date of delivery: .....

Correct drive direction as per controlpanel: .....

Voltage at thruster when running: .....

Battery cable size used: .....

The compartment where the thruster is fitted is isolated from general bilge water and has no obvious or suspected risks for flooding.

Other comments by installer:

## Important user precautions

- Ensure that you know the location of the main battery switch(es) that disconnects the thruster(s) from all power sources (batteries) so that the thruster(s) can be turned off in case of a malfunction.
- Always turn the main power switch off before touching any part of the thruster, as an incidental start while touching moving parts can cause serious injuries.
- Always turn the control device off when the thruster is not in use.
- The electromotor has a built in thermal sensor that will shut off the electromotor if it is overheating and re-engage it when it has cooled down some. This should be considered when planning your manoeuvring. The panel will show the temperature status of the thruster.
- Running the thruster at reduced effect results in less heating of the thrusters, significantly extending the operating time. Information about thruster runtime is displayed on the PJC panel
- Never use a thruster close to somebody in the water, as the thruster will draw objects close by into the tunnel and contact with the rotating propellers will cause serious injuries.
- With the boat on land, only run the thruster for a fraction of a second, as without resistance it will accelerate very fast to a damaging rpm. Also, while the thruster is in air, make sure that the propellers have come to a complete stop before performing a directions change of the thruster, as it might cause damage to the thruster.
- If the thruster stops giving thrust while the electromotor is running, chances are that there is a problem in the drive-system. You must then immediately stop trying to run it, and turn it off, as running the electromotor for more than a few seconds without resistance from the propeller, can cause serious damage to the electromotor.
- When leaving the boat always turn off the main power switch for the thruster.
- We advice to always keep the main engine(s) running while using a thruster. This will keep the batteries in a good charge condition. This will also give better performance to the thruster, as a higher voltage at the thruster results in a higher torque (power) in the electromotor.
- Please note that the performance of a thruster strongly depends on the voltage available at the electromotor. This voltage will decrease by time because aging batteries have a reduction of capacity. By installing new batteries the effect of the thruster should be back at the original level.
- Make sure that only one control is used at the same time, if two panels are operated in opposite directions at the same time the thruster will not run at all. If they are operated in the same direction the thruster will run with the largest power given by the two panels.
- If the thruster is not performing or functioning as usual, the cause for this must be found and corrected as soon as possible so to avoid causing any other or further damage to the equipment. You must also turn off the main battery switch immediately in case the problem is of electric origin.
- Never store anything (e.g. equipment, sails, ropes etc.) in the same compartment as the thruster. When the thruster runs for a longer period it will get hot and will cause damage.

### **Warning:**

- ⚠ **Tampering with the Ignition Protected stern thruster assembly or any attempt to disassemble anything on this thruster assembly inside the boat can cause an explosion with very serious consequences.**
- ⚠ **If there is a problem with your Ignition Protected stern thruster, please contact your dealer.**
- ⚠ **Danger: NEVER Disassemble any part of the Ignition Protected stern thruster assembly**

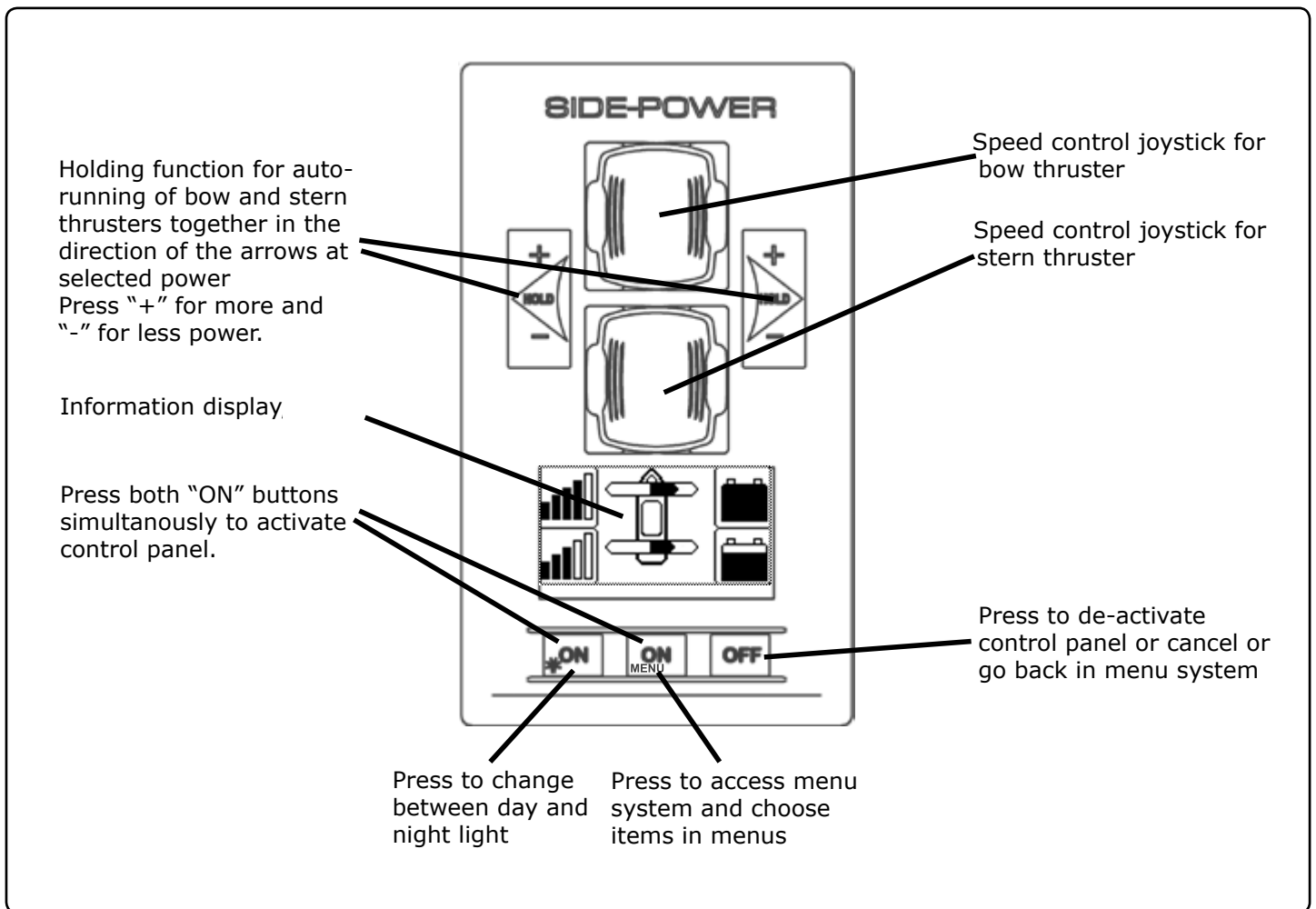

## How to use Sidepower thrusters

### How to use a bowthruster

1. Turn main power switch for the bowthruster on. (Always turn off the main power switch when not onboard.)  
A Side-Power Automatic Main Switch will turn on/off when the panel is turned on/off
2. Please take some time to exercise thruster usage in open water to avoid damages to your boat.
3. Turn the control panel on by pushing both "ON" buttons on the original Side-Power panel simultaneously.
4. Move the joystick in the direction you wish the bow to move. Other controls like footswitches or toggle-switches on the throttle can be used. These are connected to the S-link control system by a S-link interface (Refer to schematics in interface manual for installation)
5. Depending on the sideways speed of the bow, you must disengage the control device shortly before the bow is in the desired direction, as the boat will continue to move after stopping the bowthruster.

### How to use a single stern thruster

Some boats might however have installed a single stern thruster because of space limitation in the bow. In this case the stern thruster is used in the same way as a single bow thruster or moving the boat's stern.

### How to use a bow and stern thruster combined

The combination of a bow and stern thruster offers total manoeuvrability to the boat and the opportunity to move the bow and the stern separately from each other. This enables you to move the boat sideways in both directions and to turn the boat around its own axis staying at the same place. Refer to the PCJ control panel manual for detailed instructions.

- Again, if in doubt, try in open water first!

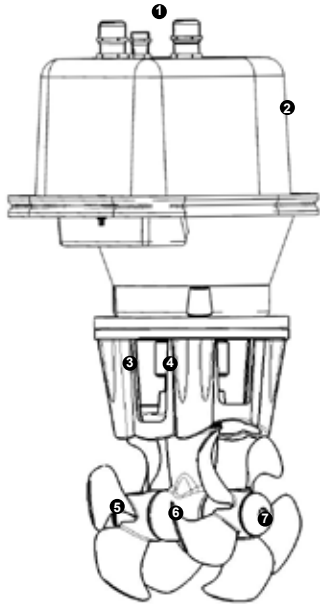

- ❶ Power & control cables
- ❷ Ignition protected casing
- ❸ Motorbracket for holding motor and gearhouse together on the tunnel.
- ❹ Flexible coupling secures the electromotor if propeller is jammed. Changeable from inside the boat.
- ❺ 5-blade skew Q-PROP propeller for ultimate performance.
- ❻ Prefilled & sealed gearleg.
- ❼ Changeable anode protects gear-house from corrosion in seawater.

- ❶ Fastening screw for anode
- ❷ Anode
- ❸ Propeller lock nut
- ❹ Washer
- ❺ Drivepin for propeller

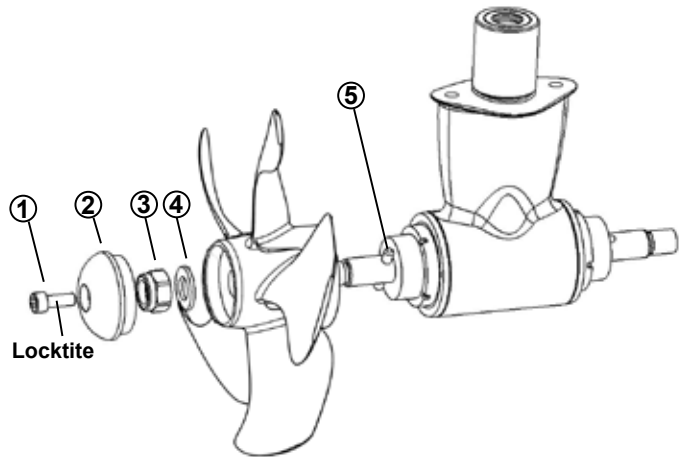

## Maintenance

- » Keep the propeller and gearhouse clean from growth by painting with antifouling before every season.  
**PS ! The anode, sealing and propeller shafts must absolutely not be painted. Be careful that you don't fill paint in the "tracks" in the gearhouse that the propeller hub moves in.**
- » Change the anode before every season, or when about half the anode is gone. Always use a sealant on the screw holding the anode to ensure that it does not fall off. Please observe that in some waterconditions it can be necessary to install an extra anode to ensure that it lasts for the whole period between regular service lifts of the boat. Consult your dealer for information on how to do this.
- » As a part of the seasonal service of your boat, and before every season, always check that:
  - The propeller is securely fastened
  - The bolts holding the electric motor to the motorbracket are fastened correctly.
  - The area where the thruster is installed is clean and dry. If there are signs of water you must try to find the source and eliminate it.
  - All electrical connections are clean and fastened firmly.
  - Make sure that your batteries are in a good condition so that the thruster gets a good voltage. Old or bad batteries will give a reduced performance from the thruster.

### Warning:

- ☠ Tampering with the Ignition Protected stern thruster assembly or any attempt to disassemble anything on this thruster assembly inside the boat can cause an explosion with very serious consequences.
- ☠ If there is a problem with your Ignition Protected stern thruster, please contact your dealer.
- ☠ **Danger: NEVER Disassemble any part of the Ignition Protected stern thruster assembly**

## Trouble shooting

Before seeking assistance at the help desk of your Sidepower dealer/distributor please perform these tests and make notes of all measurements to ensure that they have as much information as possible to work on.

**NB! All check points and solutions must be carried out after consulting the relevant information elsewhere in this manual to understand how the system is intended to work. If you are unable to understand what to check, you must consult a professional.**

	<i>Check</i>	<i>Solution</i>
»	<b>The electromotor runs, but there is no thrust.</b>	
	If the flexible coupling between the motor and driveshaft is not fitted correct inside the boat.	Check the flexible coupling/shear pin and the motor installation to ensure correct connection of the flexible coupling before re-fitting the electromotor.
	Are the propellers in the tunnel fastened correctly on the prop-shaft (key/drive pin present)	Re-fasten or replace the propeller and/or key/drive pin.
	With the motor removed, turn the driveshaft from inside the boat to feel if the gears are engaging and turning the prop-shaft.	In case of a failure inside the gearhouse, we advice to get a replacement gear-house instead of attempting to repair the internal gear and bearing system.
»	<b>The thruster does not start at all or works only in one direction.</b>	
	Refer to the PCJ Control Panel manual for detailed explanations of fault codes shown in panel display.	
»	<b>The thruster has an unexpected low performance.</b>	
	Check voltage at thruster when running.	If less than 10,5 V / 21V the thruster will not perform at specified effect.
	Check that the propeller, gearhouse and tunnel is free from growth/barnacles etc.	If there is growth in the tunnel, this will disturb/block the waterflow and especially barnacles on the propeller will greatly reduce performance.



## Warranty statement

1. The equipment manufactured by Sleipner Motor AS (The "Warrantor") is warranted to be free from defects in workmanship and materials under normal use and service.
2. This Warranty is in effect for of two years from the date of purchase by the user. Proof of purchase must be included, to establish that it is inside the warranty period.
3. This Warranty is transferrable and covers the product for the specified time period.
4. In case any part of the equipment proves to be defective, other than those parts excluded in paragraph 5 below, the owner should do the following:
  - (a) prepare a detailed written statement of the nature and circumstances of the defect, to the best of the Owner's knowledge, including the date of purchase, the place of purchase, the name and address of the installer, and the Purchaser's name, address and telephone number;
  - (b) the Owner should return the defective part or unit along with the statement referenced in the preceding paragraph to the warrantor, Sleipner Motor AS or an authorized Service Centre, postage/shipping prepaid and at the expense of the Purchaser;
  - (c) if upon the Warrantor's or Authorized Service Centre's examination, the defect is determined to result from defective material or workmanship, the equipment will be repaired or replaced at the Warrantor's option without charge, and returned to the Purchaser at the Warrantor's expense;
  - (d) no refund of the purchase price will be granted to the Purchaser, unless the Warrantor is unable to remedy the defect after having a reasonable number of opportunities to do so. Prior to refund of the purchase price, Purchaser must submit a statement in writing from a professional boating equipment supplier that the installation instructions of the Installation and Operation Manual have been complied with and that the defect remains;
  - (e) warranty service shall be performed only by the Warrantor, or an authorized Service Centre, and any attempt to remedy the defect by anyone else shall render this warranty void.
5. There shall be no warranty for defects or damages caused by faulty installation or hook-up, abuse or misuse of the equipment including exposure to excessive heat, salt or fresh water spray, or water immersion except for equipment specifically designed as water-proof.
6. No other express warranty is hereby given and there are no warranties which extend beyond those described in section 4 above. This Warranty is expressly in lieu of any other expressed or implied warranties, including any implied warranty of merchantability, fitness for the ordinary purposes for which such goods are used, or fitness for a particular purpose, and any other obligations on the part of the Warrantor or its employees and representatives.
7. There shall be no responsibility or liability whatsoever on the part of the Warrantor or its employees and representatives for injury to any person or persons, or damage to property, loss of income or profit, or any other consequential or resulting damage or cost which may be claimed to have been incurred through the use or sale of the equipment, including any possible failure or malfunction of the equipment, or part thereof.
8. The Warrantor assumes no liability for incidental or consequential damages of any kind including damages arising from collision with other vessels or objects.
9. This warranty gives you specific legal rights, and you may also have other rights which vary from country to country.

Original model		SEP 170/250TC
Model period		Part #
Ref:		24V
20	Complete IP electric motor assembly	10 0106 24
19	Key for electric motor shaft	10 1440
18	Complete flexible coupling	N/A
17	Coupling, engine side	7 1457
16	Rubber element	7 1458
15	Coupling, gearleg side	7 1457
14	Complete motor bracket	N/A
13	Bolt, motor to flange	201360
12	Bolt, flange to bracket	11031
11	Flange	921305
10	Bracket	10 0501
9	Complete gearleg	13 0601
8	Gearleg bolt	10 1080
7	Driveshaft key	10 1440
6	Gasket	10 1312
5	Anode	20 1180
4	Locknut	10 1260
3	Propeller washer	20 1181
2	Propeller drivepin	9 1241
1	Propeller (Specify Left Hand/Right Hand)	10 1271 LH/RH

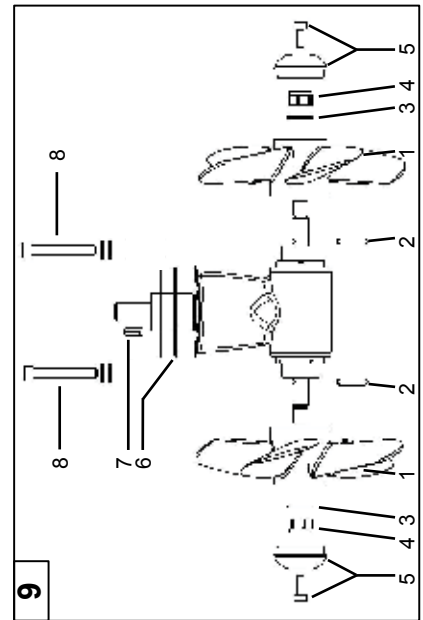
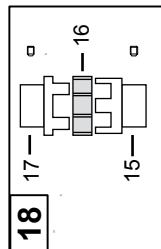
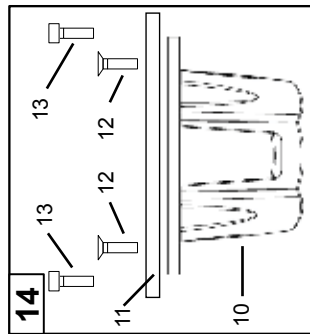
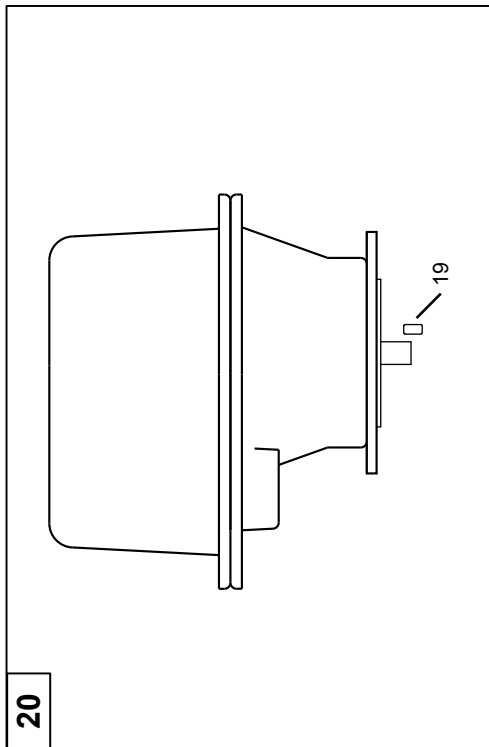

Empty rounded rectangular box at the top of the page.

Series of horizontal lines for writing, starting below the top box and ending above the bottom box.

# Worldwide sales and service



[www.side-power.com](http://www.side-power.com)



SLEIPNER MOTOR • AS P.O. Box 519 • N-1612 Fredrikstad • Norway  
Tel: +47 69 30 00 60 • Fax: +47 69 30 00 70 • [www.side-power.com](http://www.side-power.com) • [sidepower@sleipner.no](mailto:sidepower@sleipner.no)