



Allen-Bradley

***StrataScan Bar
Code Readers***

***(Cat. Nos. 2755-LHR-5B,
2755-LHR-3C,
2755-LHR-5C, and
2755-LHR-5BX1)***

User Manual



Important User Information

Because of the variety of uses for the products described in this publication, those responsible for the application and use of this control equipment must satisfy themselves that all necessary steps have been taken to assure that each application and use meets all performance and safety requirements, including any applicable laws, regulations, codes and standards.

The illustrations, charts, sample programs and layout examples shown in this guide are intended solely for purposes of example. Since there are many variables and requirements associated with any particular installation, Allen-Bradley does not assume responsibility or liability (to include intellectual property liability) for actual use based upon the examples shown in this publication.

Allen-Bradley publication SGI-1.1, *Safety Guidelines for the Application, Installation, and Maintenance of Solid-State Control* (available from your local Allen-Bradley office), describes some important differences between solid-state equipment and electromechanical devices that should be taken into consideration when applying products such as those described in this publication.

Reproduction of the contents of this copyrighted publication, in whole or in part, without written permission of Allen-Bradley Company, Inc., is prohibited.

Throughout this manual we use notes to make you aware of safety considerations:



ATTENTION: Identifies information about practices or circumstances that can lead to personal injury or death, property damage or economic loss.

Attention statements help you to:

- identify a hazard
- avoid the hazard
- recognize the consequences

Important: Identifies information that is critical for successful application and understanding of the product.

	Preface	
	Chapter Objectives	P-1
	Contents of this Manual	P-1
	Conventions Used in this Manual	P-2
	Intended Audience	P-2
	Related Publication	P-2
	Technical Support Services	P-2
Introduction to StrataScan Bar Code Readers	Chapter 1	
	Required Tools and Equipment	1-1
	Procedures	1-2
Hardware Features	Chapter 2	
	Reader Features	2-1
	Holographic Scanning Disc	2-2
	Disc Operation	2-3
	Reader LEDs	2-3
	Interface Box Features	2-4
	Decoding	2-5
	Safety Information	2-6
	Laser Labels	2-7
	Catalog Numbers 2755-LHR-5B and -5BX1	2-7
	Catalog Numbers 2755-LHR-3C and -5C	2-7
	Scan Beam Strata	2-8
	Reader Catalog Numbers	2-9
	Accessories	2-9
Designing Your System	Chapter 3	
	Setup Goals	3-1
	Symbol Height and Length	3-2
	Symbol Quality	3-2
	Symbol Orientation	3-3
	Tilt, Pitch, and Skew	3-3
	Tilt	3-4
	Pitch	3-4
	Skew	3-4
	Determining Read Range	3-5
	Catalog Number 2755-LHR-5B and 2755-LHR-5BX1	3-5
	Catalog Numbers 2755-LHR-3C and 2755-LHR-5C	3-5
Installing Your Hardware	Chapter 4	
	RS232 Installations	4-2
	PLC or PC to the Reader	4-2
	PLC or PC to the Reader and Interface Box	4-4

	Master/slave Installation (Without Interface Box)	4-8
	PLC or PC to the Reader, Reader to a Second Reader	4-8
	Master/slave Installation (With Interface Box)	4-10
	PLC or PC to the Reader, Interface Box, and a Second Reader	4-10
Maintenance and Troubleshooting	Chapter 5	
	Cleaning the Scan Window	5-1
	Troubleshooting the Readers	5-2
	Technical Support Services	5-5
Specifications	Appendix A	
	StrataScan Bar Code Reader Specifications	A-2
	Interface Box Specifications	A-3
	Power Supply Specifications	A-3
	StrataScan Bar Code Reader Dimensions	A-4
	Catalog Number 2755-LHR-5B	A-4
	Catalog Numbers 2755-LHR-3C, -5C and -5BX1	A-4
	Interface Box Dimensions	A-5
	Catalog Number 2755-LHB-1	A-5
	Power Supply Dimensions	A-5
	Replacement Part Number 77126-896-01	A-5
	Mounting Bracket Dimensions	A-6
	Replacement Part Number 77126-898-01 (for reader 2755-LHR-5B)	A-6
	Replacement Part Number 77126-898-02 (for readers 2755-LHR-3C, -5C and -5BX1)	A-7
Cable Pinouts	Appendix B	
	Reader Pinouts	B-2
	RS-232 Port	B-2
	Interface Box Port	B-3
	Power Supply Port	B-4
	Hand-Held Port Pinouts	B-4
	Interface Box Pinouts	B-5
	Power Supply Pinouts	B-6
	Reader Master/slave Cable Pinouts	B-7
	Reader Null Modem Cable Pinouts	B-8
	Interface Box Cable Pinouts	B-9
	Interface Box Master/slave Cable Pinouts	B-10
European Union Directives	Appendix C	
	Compliance to European Union Directives	C-1
	Low Voltage Directive	C-1
	Declaration of Conformity	C-2

Preface

Chapter Objectives

Read this chapter to familiarize yourself with the rest of the manual. You will learn about:

- contents of this manual
- conventions used in this manual
- intended audience
- related publications
- technical support

Contents of this Manual

The following table describes the contents of this manual.

Chapter	Title	Contents
	Preface	Describes the purpose, background, and scope of this manual. Also specifies the audience for whom this manual is intended.
1	Introduction to StrataScan Bar Code Readers	Provides an introduction for the use of the StrataScan Bar Code Readers.
2	Hardware Features	Provides an overview of the readers and interface boxes. Includes a description of accessory items.
3	Designing Your System	Gives specific criteria for setup, symbols, symbol orientation and head range.
4	Installing Your Hardware	Describes how to connect your system hardware.
5	Maintenance and Troubleshooting	Describes how to maintain and troubleshoot your system hardware.
Appendix A	Specifications	Provides physical, electrical, environmental, and functional specifications for the readers and interface boxes.
Appendix B	Cable Pinouts	Lists the cable pinouts.
Appendix C	European Union Directives	Provides requirements for readers when used within the European Union.

Conventions Used in this Manual

The following conventions are used throughout this manual.

- Bulleted lists such as this one provide information, not procedural steps.
- Numbered lists provide sequential steps.
- *Italic* type is used for emphasis.
- Text within square brackets **in this font** represent the keys you press.

Intended Audience

No special knowledge is required to understand this document or use the StrataScan Bar Code Readers (Catalog Nos. 2755-LHR-5B, 2755-LHR-3C, 2755-LHR-5C and 2755-LHR-5BX1).



ATTENTION: Use of controls or adjustments or performance of procedures other than those specified herein may result in hazardous laser light exposure.

Related Publication

The following table lists an additional publication related to the StrataScan Bar Code Readers.

Publication Number	Title
2755-6.14	StrataSet Programming Software Programming Guide
2755-921	Bar Code Basics

Technical Support Services

If you have any questions about the StrataScan Bar Code Reader, please consult this manual first. If you can't find the answer, contact your local Allen-Bradley support office or distributor.

Introduction to StrataScan Bar Code Readers

This chapter can help you to get started using the StrataScan Bar Code Readers. We base the procedures here on the assumption that you have an understanding of bar code readers and control equipment.

Because it is an introduction, this chapter *does not* contain detailed explanations about the procedures listed. It does, however, reference other chapters in this book where you can get more information.

If you have any questions or are unfamiliar with the terms used or concepts presented in the procedural steps, *always read the referenced chapters* and other recommended documentation before trying to apply the information.

This chapter tells you:

- what tools and equipment you need
- procedures for getting your system up and running

Required Tools and Equipment

Have the following tools and equipment ready:

- screwdriver
- drill
- tape measure
- personal computer with StrataScan software

Procedures

1.	Check the contents of shipping boxes.	Reference
-----------	--	------------------

Unpack the shipping boxes while making sure that the contents include:

- StrataScan Holographic reader (Catalog No. 2755-LHR-5B, -3C, -5C or 5BX1)
- Mounting bracket (Catalog No. 77126-898-01 or -02)
- Power supply (12V dc) (Catalog No. 77126-896-01)
- Disk-based Hardware User Manual (Catalog No. 2755-6.13-DISK)
- StrataScan Bar Code Readers Instruction Sheet, Pub. No. 2755-5.16
- On-line Programming Guide (Catalog No. 2755-6.14-DISK) included with Programming software
- Self-Mailer [Catalog No. 41062-002-01(A)]

Chapter 4
(Installing Your Hardware)

If the contents are incomplete, call your local Allen-Bradley representative for assistance.

2.	Design the system.	Reference
-----------	---------------------------	------------------

Each application must be evaluated carefully. Successful bar code scanning begins with quality bar code symbols and the correct number, type, and location of readers, decoders, and package sensors. Refer to the following when designing your system.

- Position the reader at a distance from the symbol that is within the range specified. A read rate test should be made to verify the range, and also to ensure optimum scanning and decoding.
- If a package sensor is used, position it so it can sense the package before the symbol reaches the scan area.

Chapter 3
(Designing Your System)

3. Install the reader.

Reference

Mount the reader(s) (Catalog Nos. 2755-LHR-3C, 2755-LHR-5C, 2755-LHR-5B, 2755-LHR-5BX1) to the mounting bracket(s) (Catalog No. 77126-898-01 or 77126-898-02).

Chapter 4
(Installing Your Hardware)

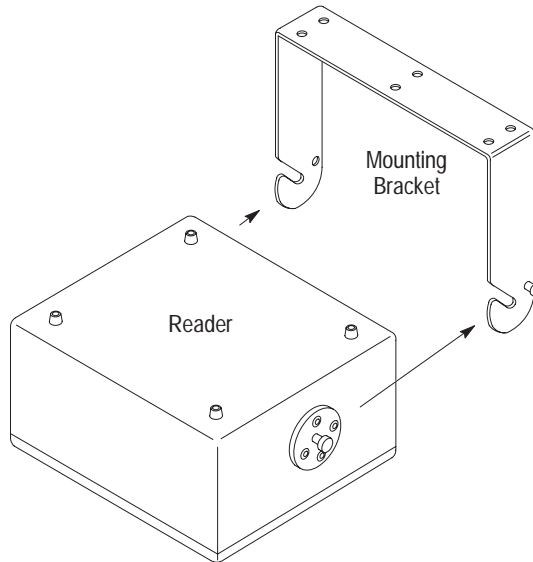

Make sure placement of the mounting bracket allows you to connect the reader to the interface box (Catalog No. 2755-LHB-1). Skip this information and step #4 if you are *not* using an interface box. The standard cable (Catalog No. 2755-LHC-2) from the interface box to the reader is 10 ft. long (3.05 m).

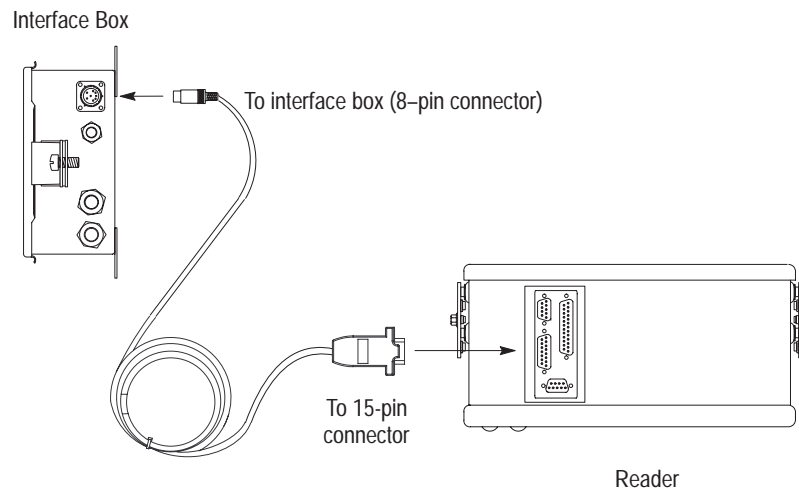

4.	Install the interface box.	Reference
-----------	-----------------------------------	------------------

Mount the interface box to your mounting surface after having attached the sensor/relay leads to the sensor terminal block *inside the interface box*. Make sure that the 3 power leads from the interface box power cord are connected to their correct locations on the power terminal block and grounding posts *inside the interface box case*.

Chapter 4
(Installing Your Hardware)

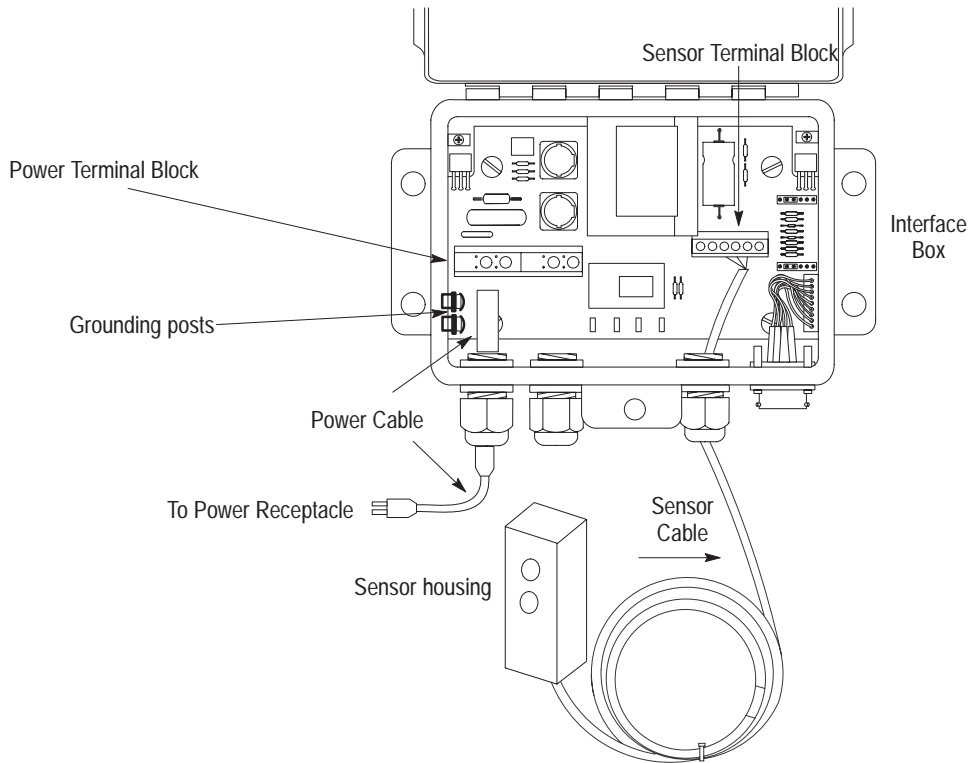
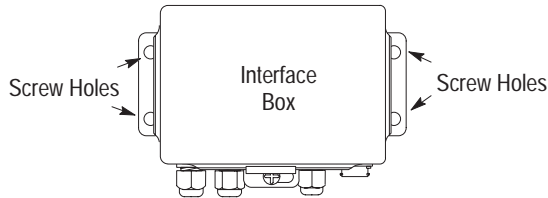

5. Install the power supply.

Reference

Place the power supply (Catalog No. 77126-896-01) within 12 ft. (3.66 m) of the scanner.

Chapter 4
(Installing Your Hardware)

6. Connect the hardware components together.

Reference

If you are using an interface box, connect the reader, power supply and package detect to the interface box. If you are *not* using an interface box, connect the reader to the host device and power supply.

Chapter 4
(Installing Your Hardware)

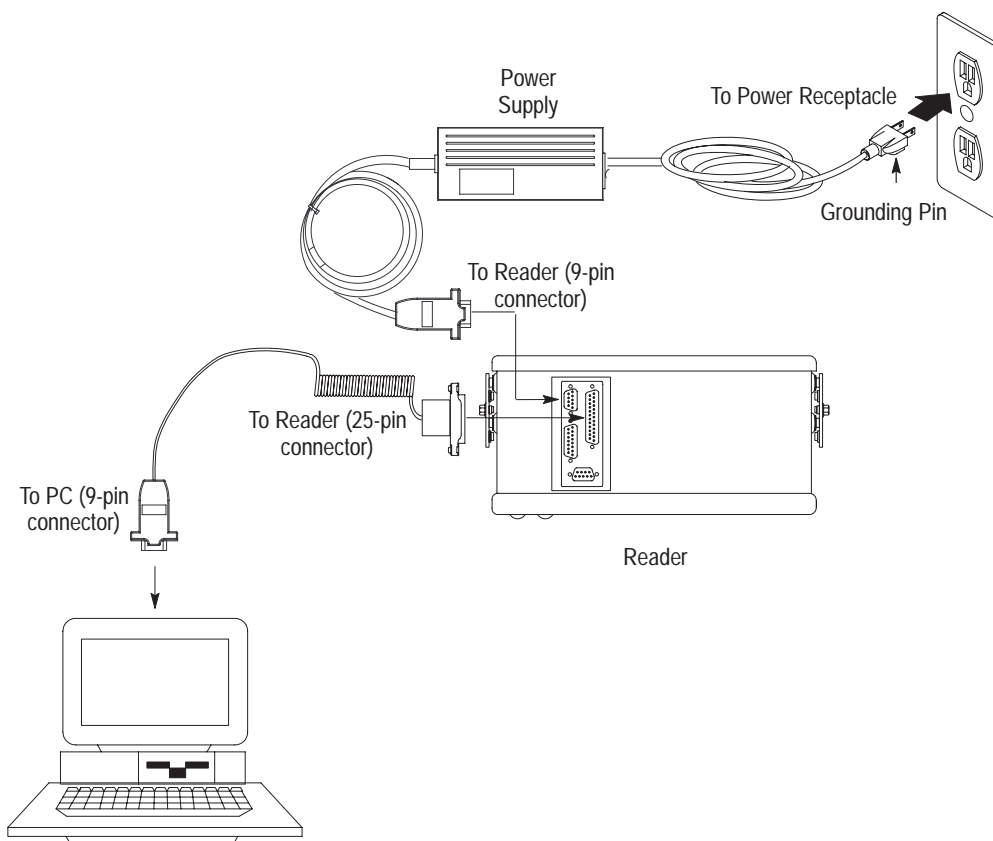
**7. Apply power to the reader system.**

Reference

After all your hardware components are installed and connected, apply power to the interface box first, then your reader system.

Chapter 4
(Installing Your Hardware)

8. Check the reader defaults, program as needed.

Reference

Make sure you have DOS or Windows-based software on your personal computer. Run StrataSet Programming software, Catalog No. 2755-LHS-1. Make sure that communications has been established with your reader. e.g., read a test bar code to verify that the default settings are correct (i.e., the reader is communicating with the configuration device). Program as needed.

StrataSet
Programming
Software
Programming
Guide
(Pub. No.
2755-6.14)

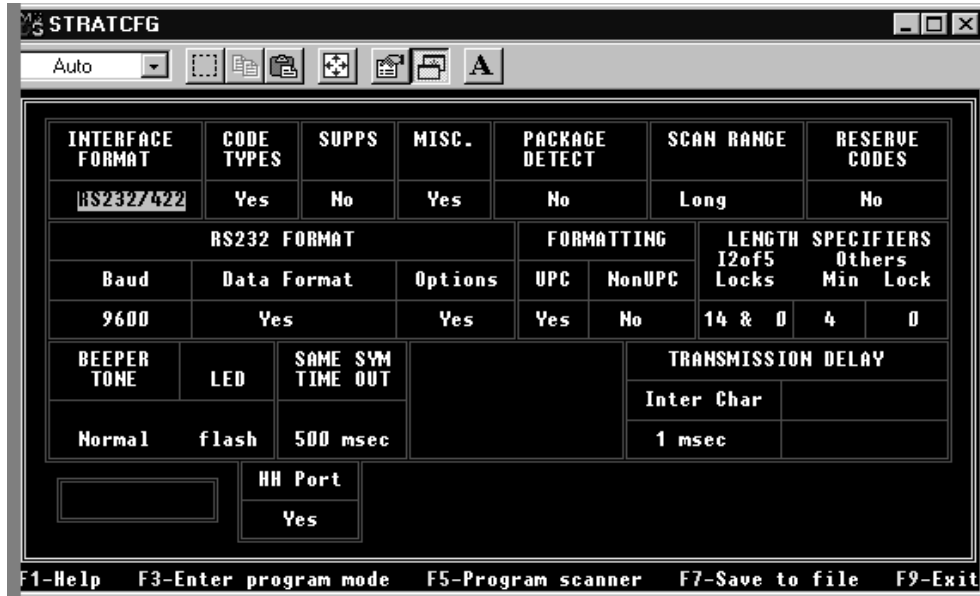
**9. Change configuration settings as necessary.**

Reference

If you need to set the reader to other than the default settings, refer to the software manual. Exit Program mode and place the reader in Run mode.

StrataSet
Programming
Software
Programming
Guide
(Pub. No.
2755-6.14)

10. Connect the system to host.**11. Run your application.**

Hardware Features

This chapter describes the features of the StrataScan Bar Code Readers (Catalog Nos. 2755-LHR-5B, 2755-LHR-3C, 2755-LHR-5C and 2755-LHR-5BX1) and interface box (Catalog No. 2755-LHB-1). Included are descriptions of:

- reader features
- interface box features
- decoding
- safety information
- scan beam options
- accessories

Reader Features

The reader features are shown below.

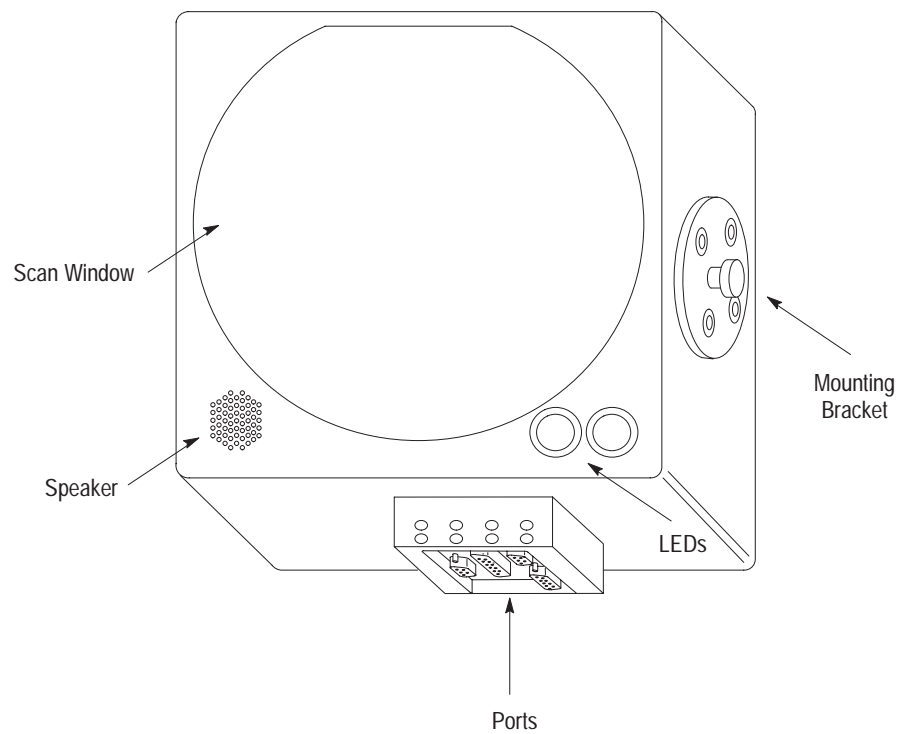

Holographic Scanning Disc

The rotating holographic disc takes the place of a focusing lens, light collection lens, and a rotating mirror. The disc contains 15 to 21 separate holographic sectors. Each sector has its own focal distance, light collection aperture, and mirror scan angle. As the disc rotates, each sector is operational, providing the reader an excellent opportunity to scan a bar code symbol.

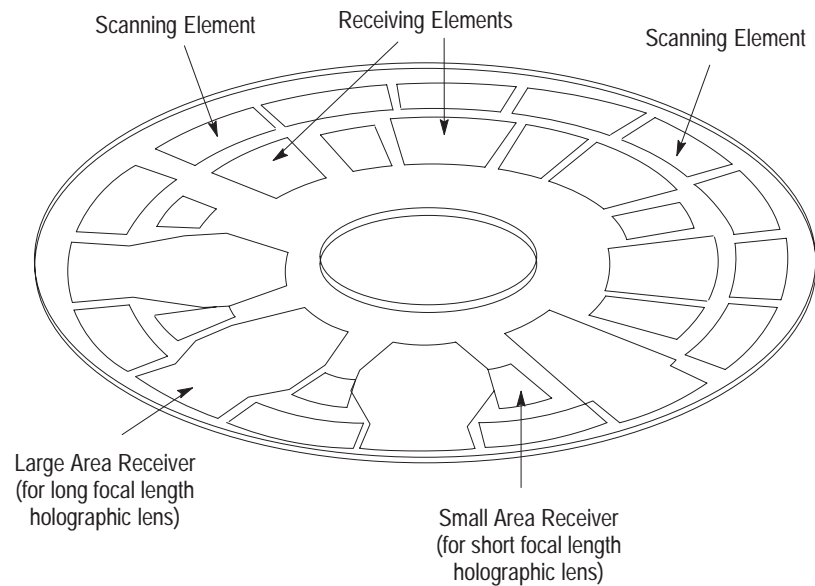

Disc Operation

As the disc rotates, the laser beam hits the disc. The laser beam is then projected onto the mirror and then projected out through the reader's window.

The reflected light travels toward the mirror. The reflected light is then projected onto the rotating disc where it is detected by an internal sensor.

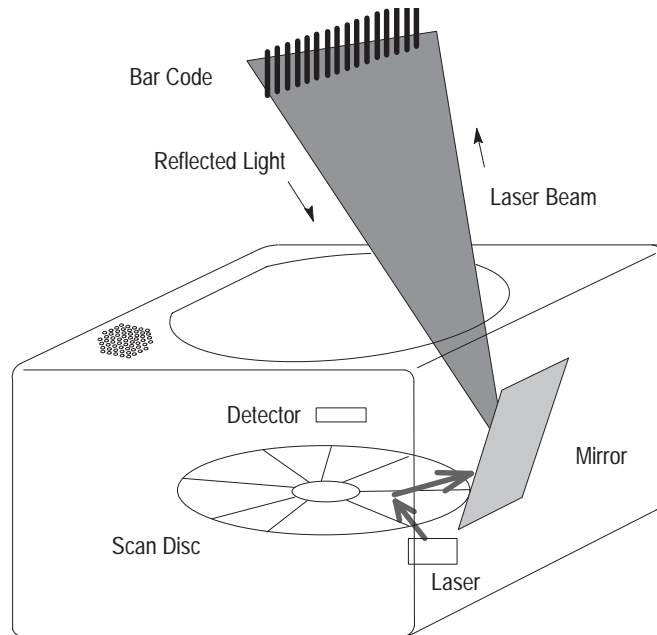

Reader LEDs

There is one green and one red LED on the readers. The table below provides an explanation of the reader's LED status.

LED State	Indicates
Solid Red	the reader has power.
Solid Red, Flashing Green	the reader has transmitted a successful read or the reader is in program mode.
Flashing Red and Green	the reader has a motor failure.



ATTENTION: With a software command, both the red and green LED's can exchange their meanings. If that command is active, then the following table with the following LED states applies.

LED State	Indicates
Solid Green	the reader has power.
Solid Green, Flashing Red	the reader has transmitted a successful read or the reader is in program mode.
Flashing Green and Red	the reader has a motor failure.

Interface Box Features

The interface box routes signals between the readers and an external package detect. The interface box has the following components:

- Power transformer. Supplies a stepped down and isolated voltage that produces the 12V dc power for the interface box and external sensor.
- F2 control fuse holder. Contains the 12V dc fuse for the interface box.
- F1 triac fuse holder. Contains the fuse for the triac output.
- Power terminal block. Provides the input connection point for the AC line that supplies power to the interface box.
- Triac terminal block. Provides the output connection point for the reader-controlled power output.
- LED status indicators. Provides the status of power supply, package detect, and sensor alarm circuits.
- Voltage selector switch. Allows you to configure the interface box to match the incoming line voltage.
- J1 jumper. Allows you to configure the sensor input.
- J2 jumper. Allows you to configure the sensor input alarm.
- Package detect terminal block. Provides the connection point for the package detect.



ATTENTION: Before applying power to the interface box, make sure the voltage selector switch is in the correct position.

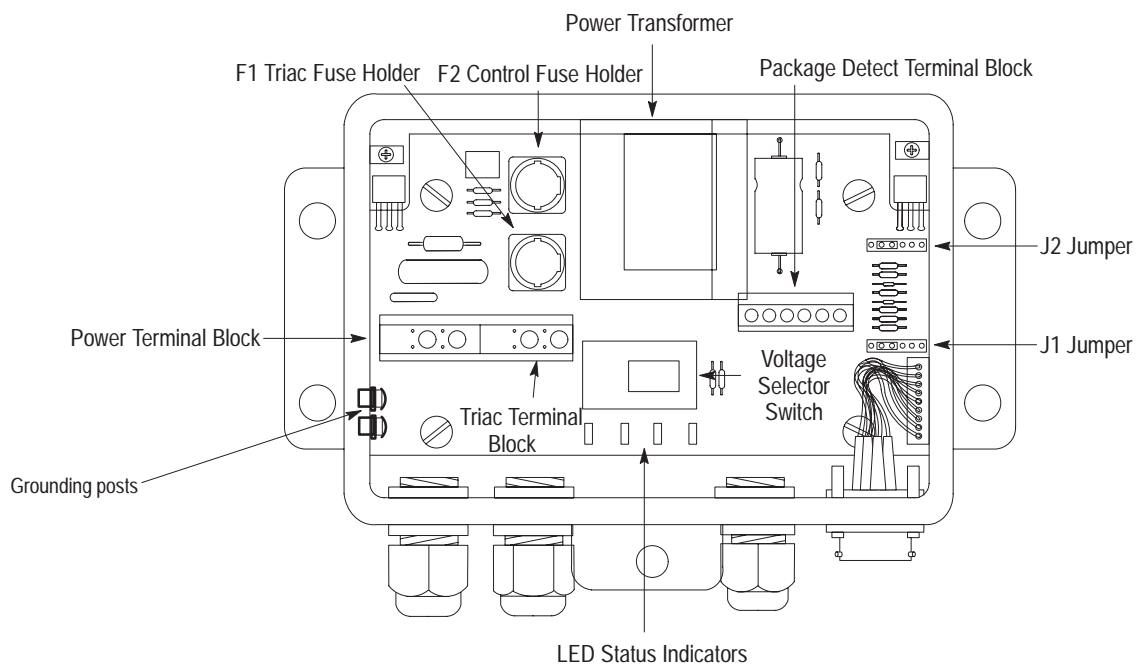

Decoding

The readers can decode the following symbologies:

- UPC/EAN
- Codabar
- Code 11
- Code 39
- Code 39 Full ASCII
- Code 39 Mod 43
- Code 93
- Code 128
- Interleaved 2 of 5
- Interleaved 2 of 5 Mod 10
- Paraf
- MSI Plessey
- MSI Plessey Mod 10 Check digit
- MSI Plessey Mod 10/10 Check digit
- UK Plessey
- Airline 2 of 5
- Matrix 2 of 5
- telepen

Refer to Chapter 2 of *StrataSet Programming Software Programming Guide* (Publication No. 2755-6.14) for more information on the code types listed above.

Safety Information

This equipment has been tested and found to comply with limits for a Class A digital device, pursuant to Part 15 of the FCC Rules. These limits are designed to provide reasonable protection against harmful interference when the equipment is operated in a commercial environment. This equipment generates, uses and can radiate radio frequency energy and, if not installed and used in accordance with the instruction manual, may cause harmful interference to radio communications. Operation of this equipment in a residential area is likely to cause harmful interference, in which case the user will be required to correct the interference at his/her own expense. Any unauthorized changes or modifications to this equipment could void the user's authority to operate this device.

This digital apparatus does not exceed the Class A limits for radio noise emissions from digital apparatus set out in the Radio Interference Regulations of the Industry Canada.



ATTENTION: Never attempt to look at the laser beam, even if the scanner appears to be nonfunctional. Doing so could result in hazardous laser light exposure.



ATTENTION: Use of controls, adjustments, or performance of procedures other than those specified herein may result in hazardous laser light radiation exposure.



ATTENTION: Never open the scanner in an attempt to look into the device or to service the laser scanner.



ATTENTION: The use of optical instruments with the laser equipment will increase eye hazard.



ATTENTION: If it is necessary to disable the scanner light emission, unplug the power supply's AC power plug from its AC power source.

Laser Labels

Be aware of the following laser caution, danger and avoid exposure labels on the readers. Their locations vary depending upon reader catalog number shown below:

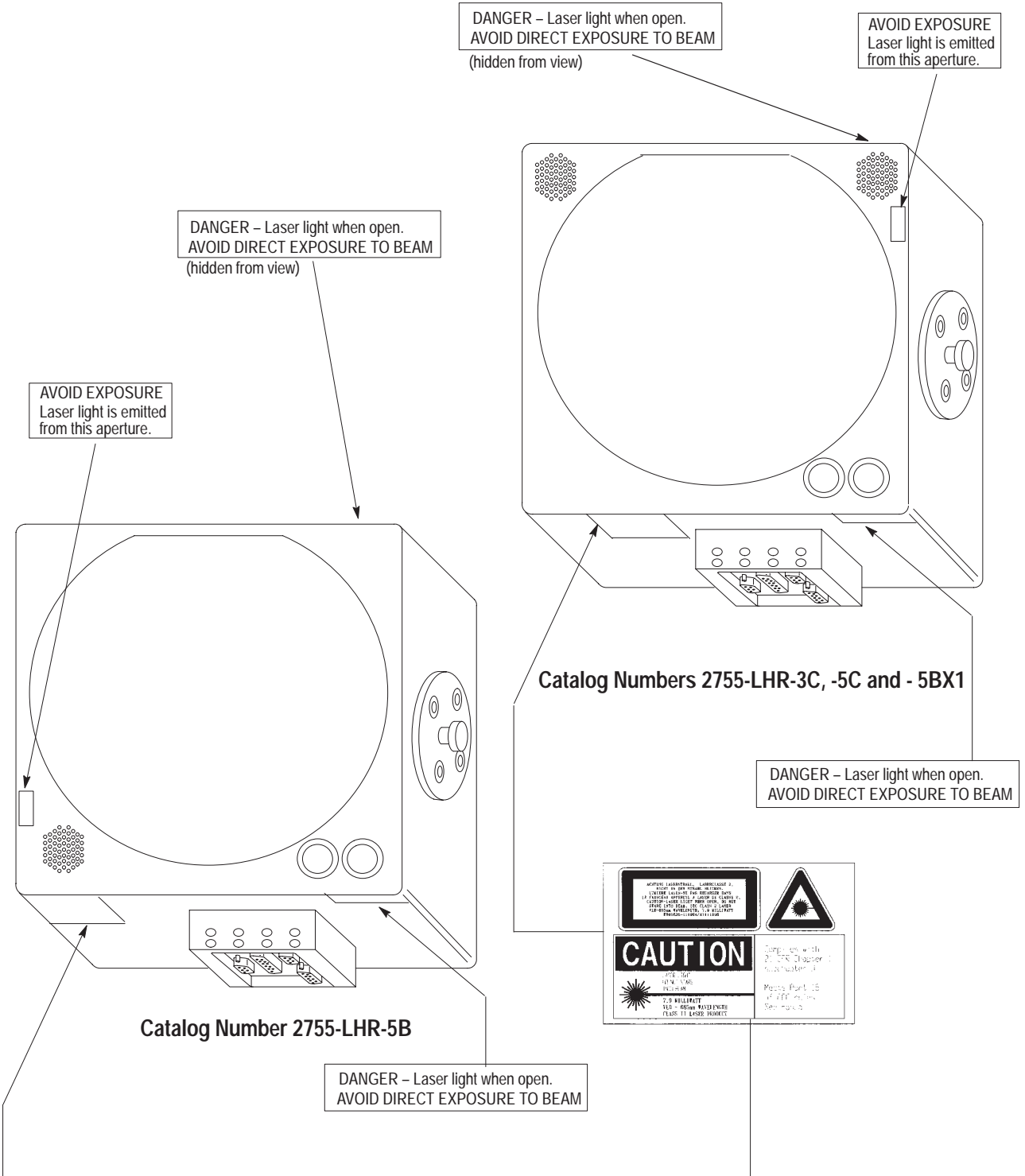

Scan Beam Strata

Scan beams are projected to focus in different strata as shown below. The various overlapping focus areas give the StrataScan holographic reader its great depth of field.

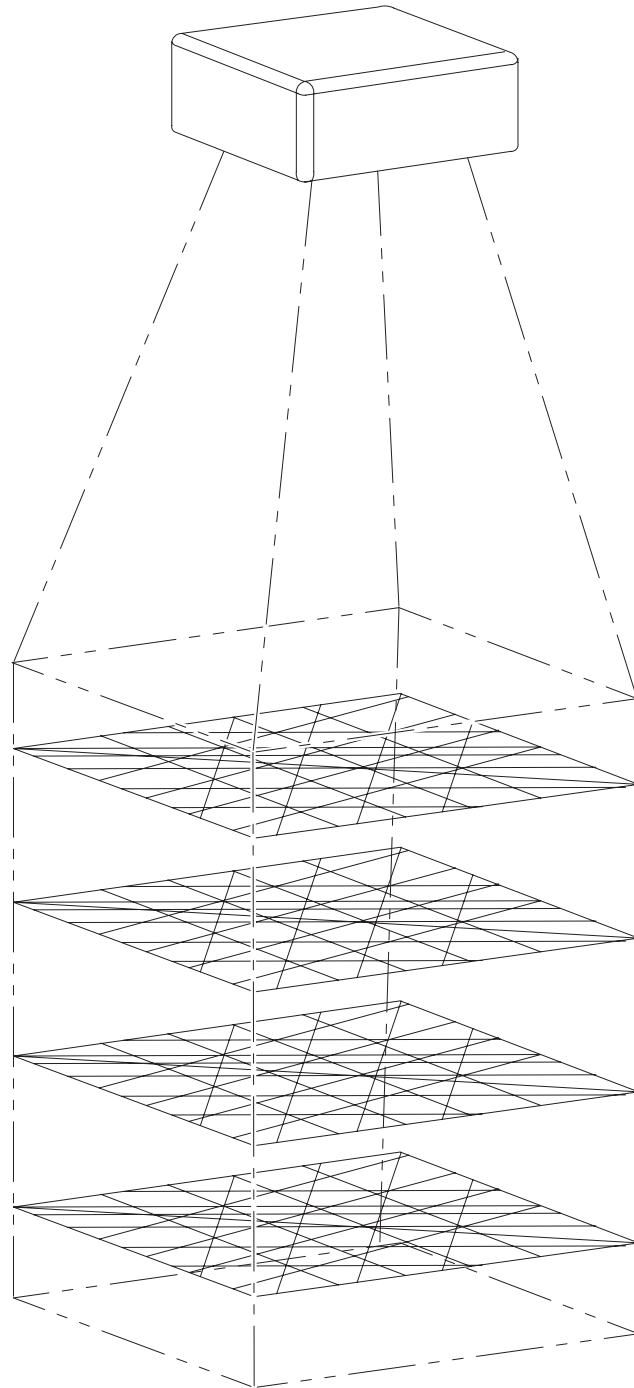

Note: This pattern or number of strata is different for each of the reader models.

Reader Catalog Numbers

The following readers have their corresponding catalog numbers:

Description	Catalog Number
High density, five laser holographic reader	2755-LHR-5B
Medium density, three laser holographic reader	2755-LHR-3C
Medium density, five laser holographic reader	2755-LHR-5C
High density, five laser holographic reader	2755-LHR-5BX1

Accessories

The following accessories are available with the readers:

Description	Catalog Number
Interface box	2755-LHB-1
Master/Slave cable for readers	2755-LHC-1
Interface box cable	2755-LHC-2
Master/Slave cable for interface box	2755-LHC-3
Null modem cable for readers	2755-LHC-11
Unterminated communications cable	2755-LHC-12
Replacement cover for 2755-LHR-5B	77126-899-01
Replacement cover for 2755-LHR-3C, -5C and -5BX1	77126-899-02
Replacement mounting bracket for 2755-LHR-5B	77126-898-01
Replacement mounting bracket for 2755-LHR-3C and 2755-LHR-5C	77126-898-02
StrataScan Programming Software	2755-LHS-1
Replacement power supply for the readers	77126-896-01

Designing Your System

This chapter provides the information needed to set up a scanner system correctly. Items include:

- setup goals
- symbol height and length
- symbol quality
- symbol orientation
- tilt, pitch, and skew
- determining read range

Setup Goals

Each application must be evaluated carefully. Successful bar code scanning begins with quality bar code symbols and the correct number, type, and location of readers, decoders, and package sensors. Refer to the following when designing your scanner system.

- Adjust, if necessary, the symbol speed and/or the distance between bar-coded packages to ensure that the bar code symbol is being read.
- Position the reader at a distance from the symbol that is within the range specified. A read rate test should be made to verify the range, and also to ensure optimum scanning and decoding.
- If a package sensor is used, position it so it can sense the package before the symbol reaches the scan area.

Symbol Height and Length

The height is measured from one end of a bar to the other, and its length is always the distance from one end of the symbol to the other, including the Quiet Zones. A Quiet Zone is the empty space before or after the bars, and is usually equal to 10 times the Narrow Element Width.

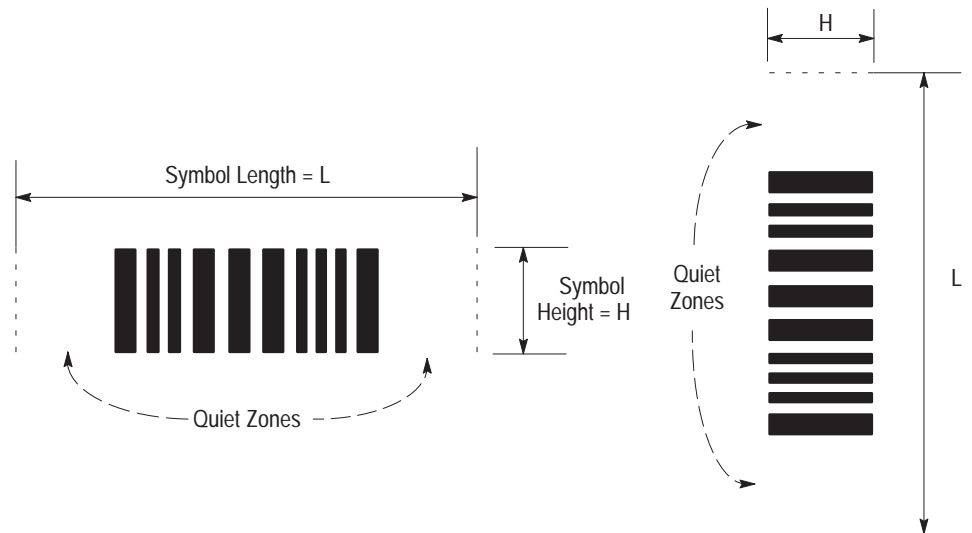

The aspect ratio (symbol height to symbol length) cannot be greater than 1.7:1 for Catalog No. 2755-LHR-3C and 2.5:1 for Catalog No. 2755-LHR-5C.

Symbol Quality

A bar code reader cannot reliably read a poor quality symbol. Test proposed bar code symbol samples to ANSI Standard X3.182-1990, Bar Code Print Quality Guideline.

- Low-cost verifiers that can test this standard are available from several companies.
- Symbol samples can be submitted to an independent symbology testing company.

The ANSI guideline specified six parametric tests plus two pass/fail tests to determine the printed symbol quality. The tests result in an overall letter grade of A, B, C, D or F assigned to the symbol. In general, symbols are most decodable in the A range with diminishing quality through F. An F or failure occurs because a symbol does not conform to a legitimate bar code symbology, whereas a D grade has a better chance of being read. And a C has a still better chance of being read by more readers than a D. And so on.

Symbol Orientation

Bar code symbols must have the correct aspect ratio to be read by the reader. A scan line must cross every bar, space, and both quiet zones on the same sweep.



Tilt, Pitch, and Skew

Refer to the figure below for various package orientations. Tilt, pitch, and skew can affect the scan aspect ratio, and as a result, can affect the reader's ability to read bar code symbols.

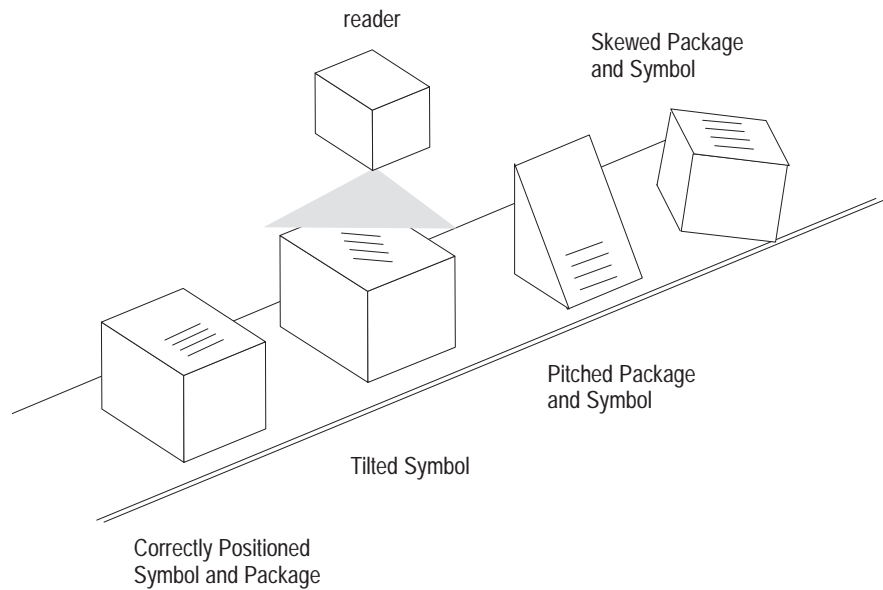

Tilt

A symbol is tilted when the symbol's bars are not 90° to one of the scan lines. The symbol can be read with any tilt, provided a scan line passes through all bars and quiet zones on each sweep for the required minimum number of scans. Tilt may reduce the number of scans in a given application.

Pitch

A symbol is pitched when the symbol's bars are at different distances from the reader. From the reader's perspective, a pitched symbol appears to have a smaller narrow element width than it actually has. This may reduce both the read rate and the read range. However, the symbol can still be read if the apparent narrow element width is within the reader's specifications.

Skew

A symbol is skewed when the ends of the symbol's bars are not at the same distance from the reader. The symbol can be read if the distance of both ends of the bar are within the reader's read range, and the skew is less than ± 40 degrees from the centerline. Unlike pitch, skew does not affect the read range.

Determining Read Range

The readers can read bar code symbols at various distances depending upon the type of reader and the narrowest bar code element width (width of smallest bar or space).

Catalog Number	Minimum Bar Code Width	Read Range	Maximum Scan Width
2755-LHR-5B	0.008 in. (0.20 mm)	18 to 38 in. (45.7 to 96.5 cm)	12 in. (30.5 cm)
	0.025 in. (0.64 mm)	18 to 38 in. (45.7 to 96.5 cm)	12 in. (30.5 cm)
2755-LHR-3C	0.013 in. (0.33 mm)	36 to 78 in. (91.4 to 198.1 cm)	22 in. (55.9 cm)
	0.04 in. (1.02 mm)	36 to 78 in. (91.4 to 198.1 cm)	22 in. (55.9 cm)
2755-LHR-5C	0.013 in. (0.33 mm)	34 to 64 in. (86.4 to 162.6 cm)	22 in. (55.9 cm)
	0.04 in. (1.02 mm)	36 to 78 in. (91.4 to 198.2 cm)	22 in. (55.9 cm)
2755-LHR-5BX1	0.008 in. (0.20 mm)	33 to 43 in. (83.8 to 109.2 cm)	13 in. (33.0 cm)
	0.025 in. (0.64 mm)	33 to 43 in. (83.8 to 109.2 cm)	13 in. (33.0 cm)

Catalog Number 2755-LHR-5B

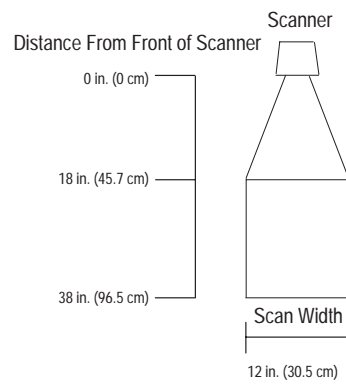

Catalog Number 2755-LHR-5BX1

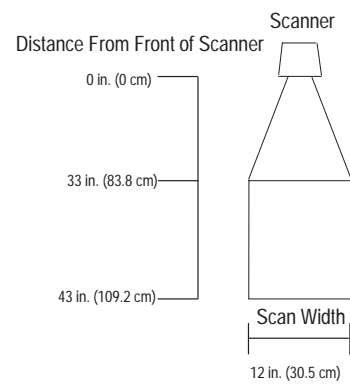

Catalog Numbers 2755-LHR-3C and 2755-LHR-5C

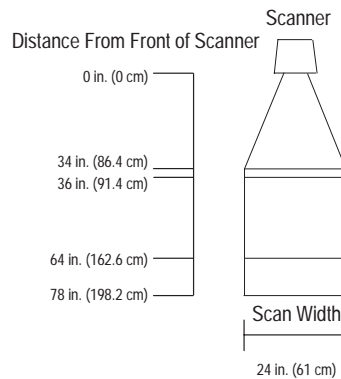

Installing Your Hardware

This chapter provides the information needed to install the readers, their mounting brackets, their power supplies, and interface boxes. Items include:

- RS-232 installations
- master/slave installations

Because of the variety of uses for the information, users of and those responsible for applying this information must satisfy themselves as to the acceptability of each application and use of the program. In no event will Allen-Bradley Company be responsible or liable for indirect or consequential damages resulting from the use of application of this information.

The examples shown in this document are intended solely to illustrate the principles of the bar code reader and some of the methods used to apply them. Particularly because of the many requirements associated with any particular installation, Allen-Bradley Company cannot assume responsibility or liability for actual use based upon the illustrative uses and applications.

RS232 Installations

Refer to the following sections to install your system hardware, based on the type of equipment you select:

PLC or PC to the Reader

1. Make sure your system is planned properly. Refer to Chapter 3 for information about planning your system.
2. Refer to Appendix A for dimensions of readers, mounting brackets, power supplies, and interface boxes. Cable pinouts are shown in Appendix B.
3. Install the mounting bracket (Catalog Nos. 77126-898-01 or 77126-898-02) for the readers (Catalog Nos. 2755-LHR-5B, 2755-LHR-3C, 2755-LHR-5C, and 2755-LHR-5BX1).

Make sure placement of the mounting bracket allows you to connect the reader to the PLC or PC and power supply. Also make sure bracket placement provides the correct read range for the reader.

The maximum cable length from the reader to another device is 50 ft. (15.24 m) when using RS232. Use RS422 when distances reach up to 2000 feet (609.6 m).

4. Mount the reader to the mounting bracket.
5. Install your PLC or PC. For proper installation refer to the installation information provided with each product.

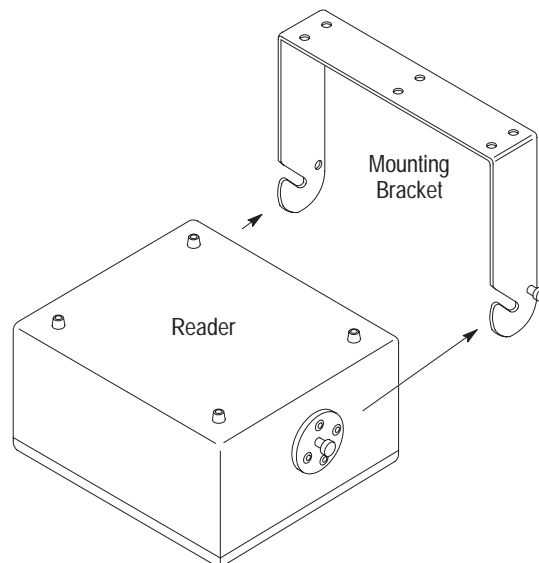

6. Connect the null modem cable (Catalog No. 2755-LHC-11) to the PLC or PC (9-pin connector) and the reader (25-pin connector).
7. Place the power supply (Catalog No. 77126-896-01) within 12 ft. (3.66 m) of the reader. Connect the power supply to the reader.

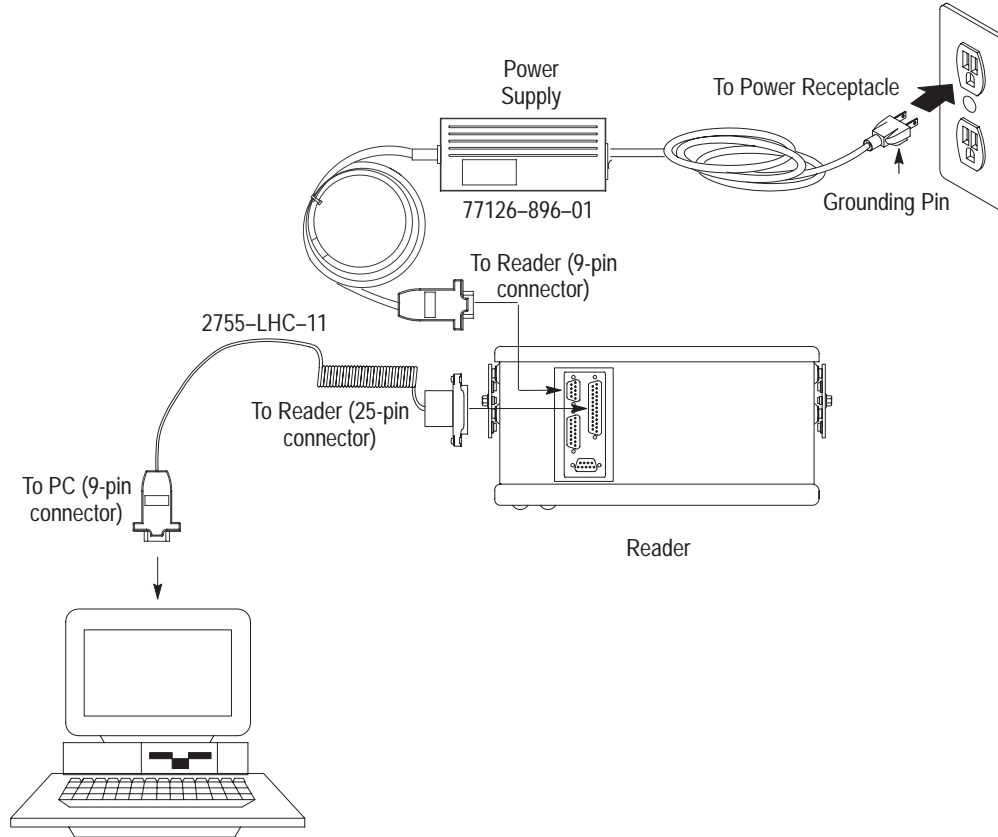

8. Connect the power supply cable to the power supply and to the power receptacle supplying 100/240V ac.

When power is applied to the reader, the green LED flashes on and off, then the red LED turns on and remains on. A beep is emitted from the reader as well, indicating the reader has power. Scan beams are also emitted from the reader.

PLC or PC to the Reader and Interface Box

1. Make sure your system is planned properly. Refer to Chapter 3 for information about planning your system.
2. Refer to Appendix A for dimensions of readers, mounting brackets, power supplies, and interface boxes. Cable pinouts are shown in Appendix B.
3. Install the mounting bracket (Catalog Nos. 77126-898-01 or 77126-898-02) for the readers (Catalog Nos. 2755-LHR-5B, 2755-LHR-3C, 2755-LHR-5C, and 2755-LHR-5BX1).

Make sure placement of the mounting bracket allows you to connect the reader to the PLC or PC, interface box, and power supply. Also make sure bracket placement provides the correct read range for the reader.

The maximum cable length from the reader to another device is 50 ft. (15.24 m) when using RS232. Use RS422 when distances reach up to 2000 feet (609.6 m).

4. Mount the reader to the mounting bracket.

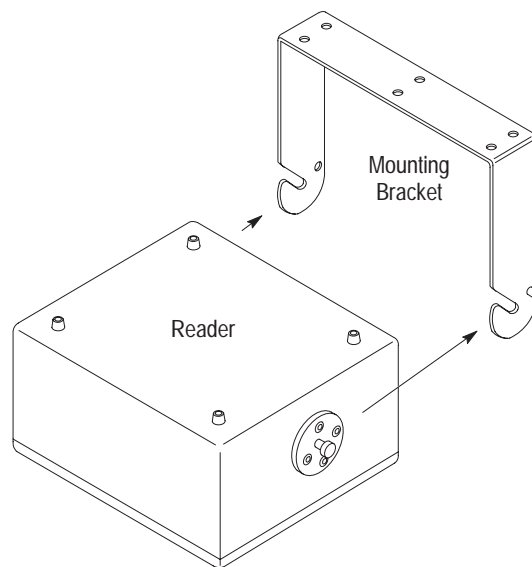

5. Install your PLC or PC. For proper installation refer to the installation information provided with each product.

6. Connect the null modem cable (Catalog No. 2755-LHC-11) to the PLC or PC (9-pin connector) and the reader (25-pin connector).
7. Place the power supply (Catalog No. 77126-896-01) within 12 ft. (3.66 m) of the reader. Connect the power supply to the reader. Connect the power supply to the reader.
8. Connect the interface box cable (Catalog No. 2755-LHC-2) to the interface box and the reader. The 15-pin end of the cable connects to the reader and the 8-pin end to the interface box. Make sure you lock into place the interface box end of the cable.

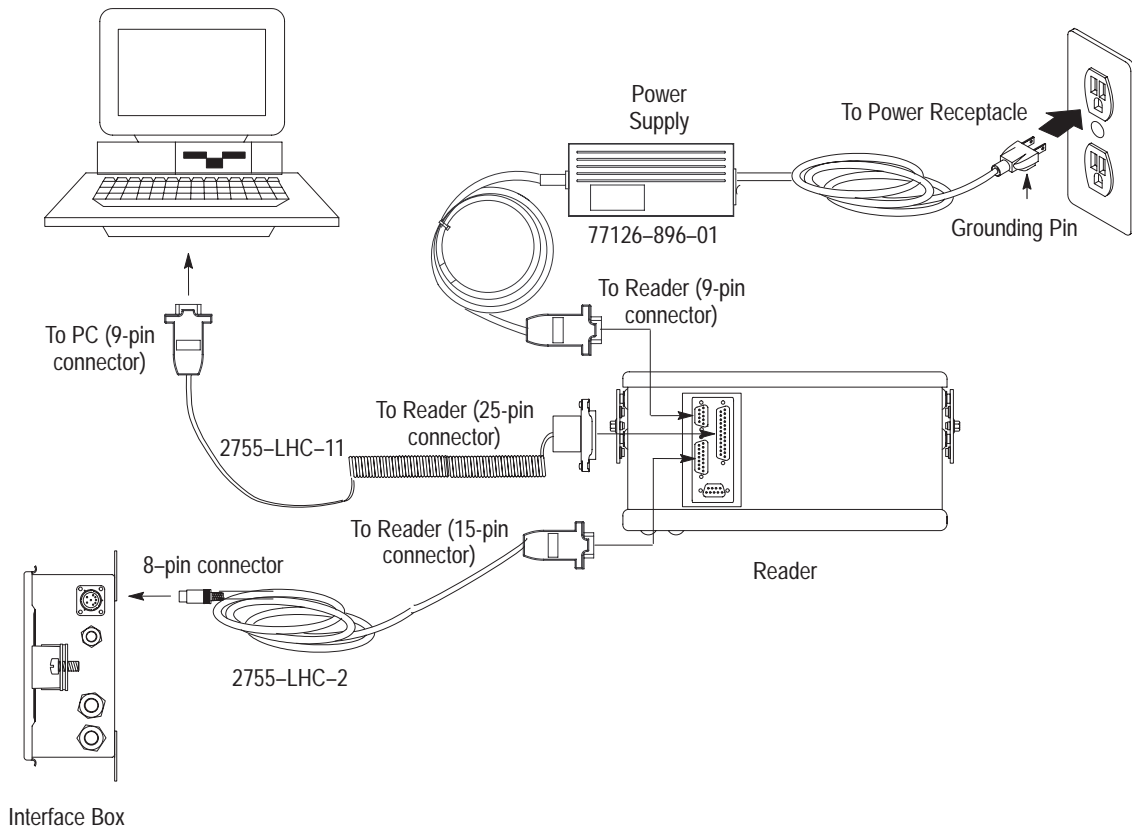

9. Connect your sensor (PhotoSwitch 6000 or 9000 Series) to the interface box by attaching the sensor leads to the sensor terminal block *inside the interface box*. The sensor itself will have the proper connection scheme imprinted on its housing. Follow the method shown there. For instance, brown to +12V out, white to sink-in, blue to common, black to source. (Black is often disregarded.)

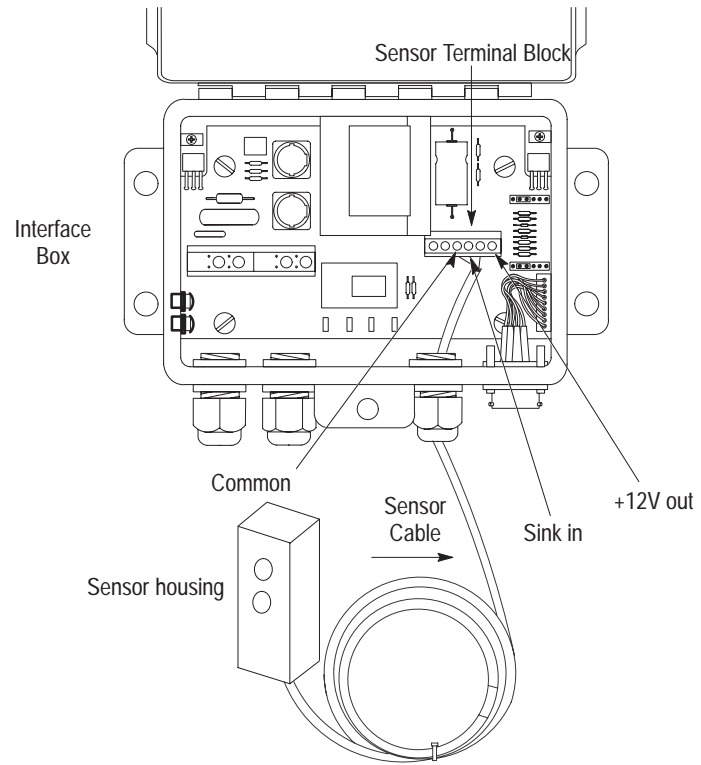

10. Mount the interface box (Catalog No. 2755-LHB-1). Its dimensions are shown in Appendix A.

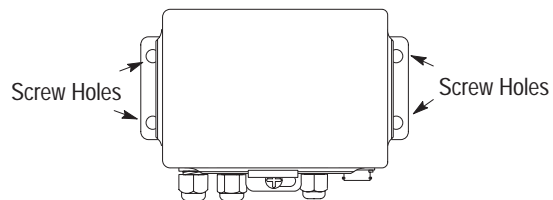



ATTENTION: Before connecting power, make sure that the 3 power leads from the interface box power cord are connected to their proper locations on the power terminal block and grounding posts *inside the interface box case*. A domestic and a European example are shown in the following illustration. Make sure that the interface box is connected to an ac source per local/regional electrical codes.

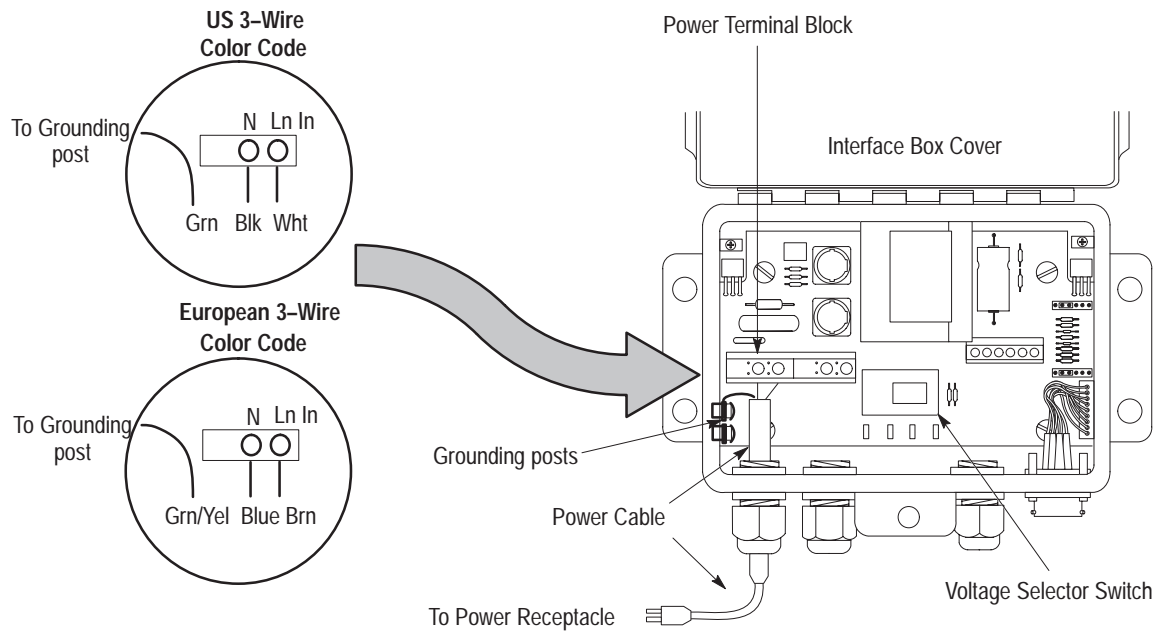

ATTENTION: Before applying power to the interface box, make sure the voltage selector switch is in the correct position.

11. Connect the interface box to the power receptacle supplying 100/240V ac.
12. Connect the power supply cable to the power supply and to the power receptacle supplying 100/240V ac.

When power is applied to the reader, the green LED flashes on and off, then the red LED turns on and remains on. A beep is emitted from the reader as well, indicating the reader has power. Scan beams are also emitted from the reader.

When power is applied to the interface box, the green 12V LED turns on and remains on.

Master/slave Installation (Without Interface Box)

Refer to the following steps to install your system hardware:

PLC or PC to the Reader, Reader to a Second Reader

1. Make sure your system is planned properly. Refer to Chapter 3 for information about planning your system.
2. Refer to Appendix A for dimensions of readers, mounting brackets, power supplies and interface boxes. Cable pinouts are shown in Appendix B.
3. Install the mounting brackets (Catalog Nos. 77126-898-01 or 77126-898-02) for the readers (Catalog Nos. 2755-LHR-5B, 2755-LHR-3C, 2755-LHR-5C and 2755-LHR-5BX1).

Make sure placement of the mounting brackets allows you to connect the first reader to the PLC or PC, interface box, and power supply. It should also allow you to connect the second reader to the interface box and a power supply. Also make sure bracket placement provides the correct read range for both readers.

The maximum cable length from the reader to another device is 50 ft. (15.24 m) when using RS232. Use RS422 when distances reach up to 2000 feet (609.6 m).

4. Mount each reader to its mounting bracket.

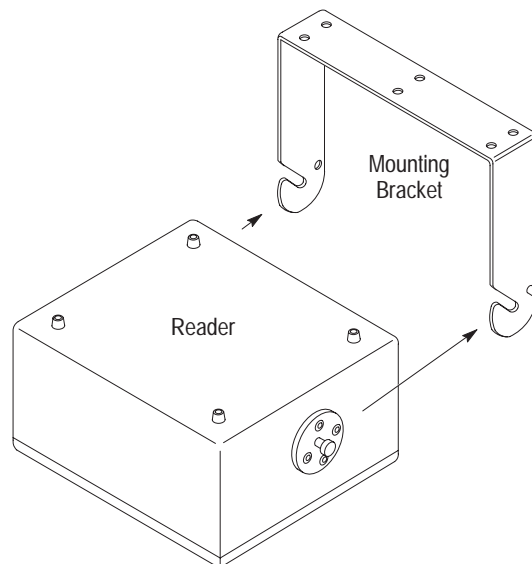

5. Install your PLC or PC. For proper installation refer to the installation information provided with each product.

6. Connect the PLC or PC to the master reader (25-pin connector).
7. Connect the Master/Slave cable (Catalog No. 2755-LHC-1) to the first reader (master) and the second reader (slave). The 15-pin end of the cable connects to the master reader.
8. Connect the 25-pin end of the cable to the slave reader.
9. Connect each reader to a power supply.

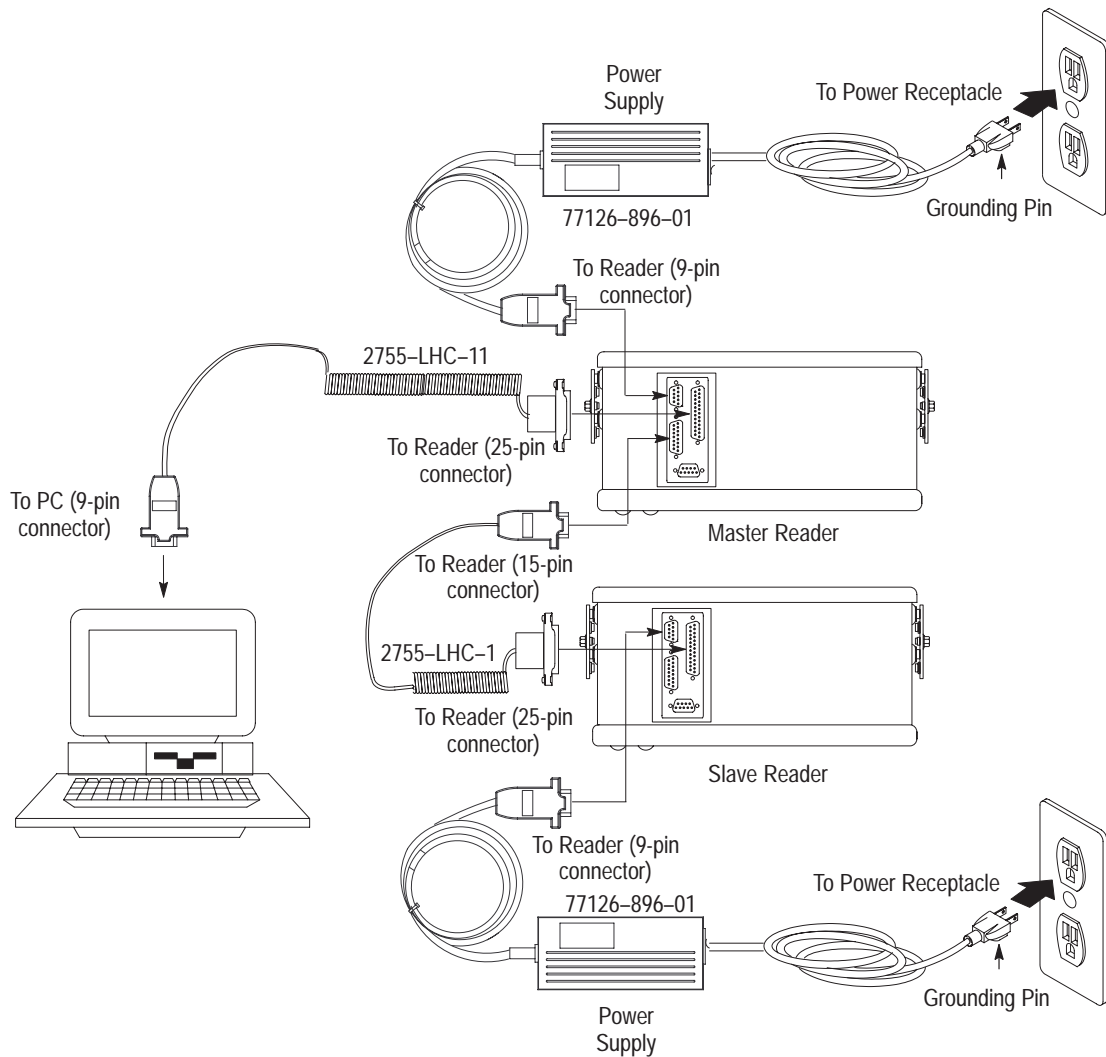



ATTENTION: To prevent unsuccessful programming of your master/slave scanner configuration, follow this setup sequence when installing master/slave option:

1. Connect master and slave scanners with the appropriate master/slave cable.
2. Connect Allen–Bradley StrataScan Configuration software to the master scanner.
3. Apply power to the master/slave units.
4. Program the master scanner as you would a regular scanner with the StrataScan Configuration software.
5. The master scanner automatically programs the slave to the same parameters.

10. Connect each power supply cable to each power supply and to the power receptacle supplying 100/240V ac.

When power is applied to each reader, the green LED flashes on and off, then the red LED turns on and remains on. A beep is emitted from each reader as well, indicating the reader has power. Scan beams are also emitted from each reader.

Master/slave Installation (With Interface Box)

Refer to the following steps to install your system hardware:

PLC or PC to the Reader, Interface Box, and a Second Reader

1. Make sure your system is planned properly. Refer to Chapter 3 for information about planning your system.
2. Refer to Appendix A for dimensions of readers, mounting brackets, power supplies and interface boxes. Cable pinouts are shown in Appendix B.
3. Install the mounting brackets (Catalog Nos. 77126-898-01 or 77126-898-02) for the readers (Catalog Nos. 2755-LHR-5B, 2755-LHR-3C, 2755-LHR-5C, and 2755-LHR-5BX1).

Make sure placement of the mounting brackets allows you to connect the first reader to the PLC or PC, interface box, and power supply. It should also allow you to connect the second reader to the interface box and a power supply. Also make sure bracket placement provides the correct read range for both readers.

The maximum cable length from the reader to another device is 50 ft. (15.24 m) when using RS232. Use RS422 when distances reach up to 2000 feet (609.6 m).

4. Mount each reader to its mounting bracket.

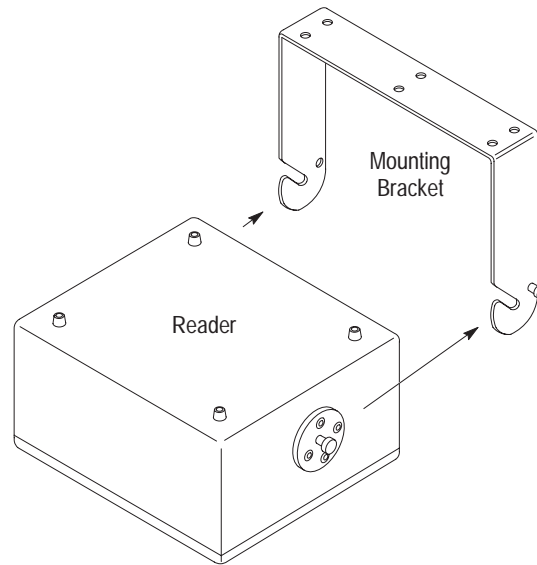

5. Install your PLC or PC. For proper installation refer to the installation information provided with each product.

6. Connect the PLC or PC to the first reader.
7. Connect the Master/Slave Interface Box Cable (Catalog No. 2755-LHC-3) to the first reader (master) and the interface box. Make sure you lock into place the interface box end of the cable. The 15-pin end of the cable connects to the master reader.
8. Connect each reader to a power supply.
9. Connect the Master/Slave Interface Box Cable (Catalog No. 2755-LHC-3) to the second reader (slave). The 25-pin end of the cable connects to the slave reader.

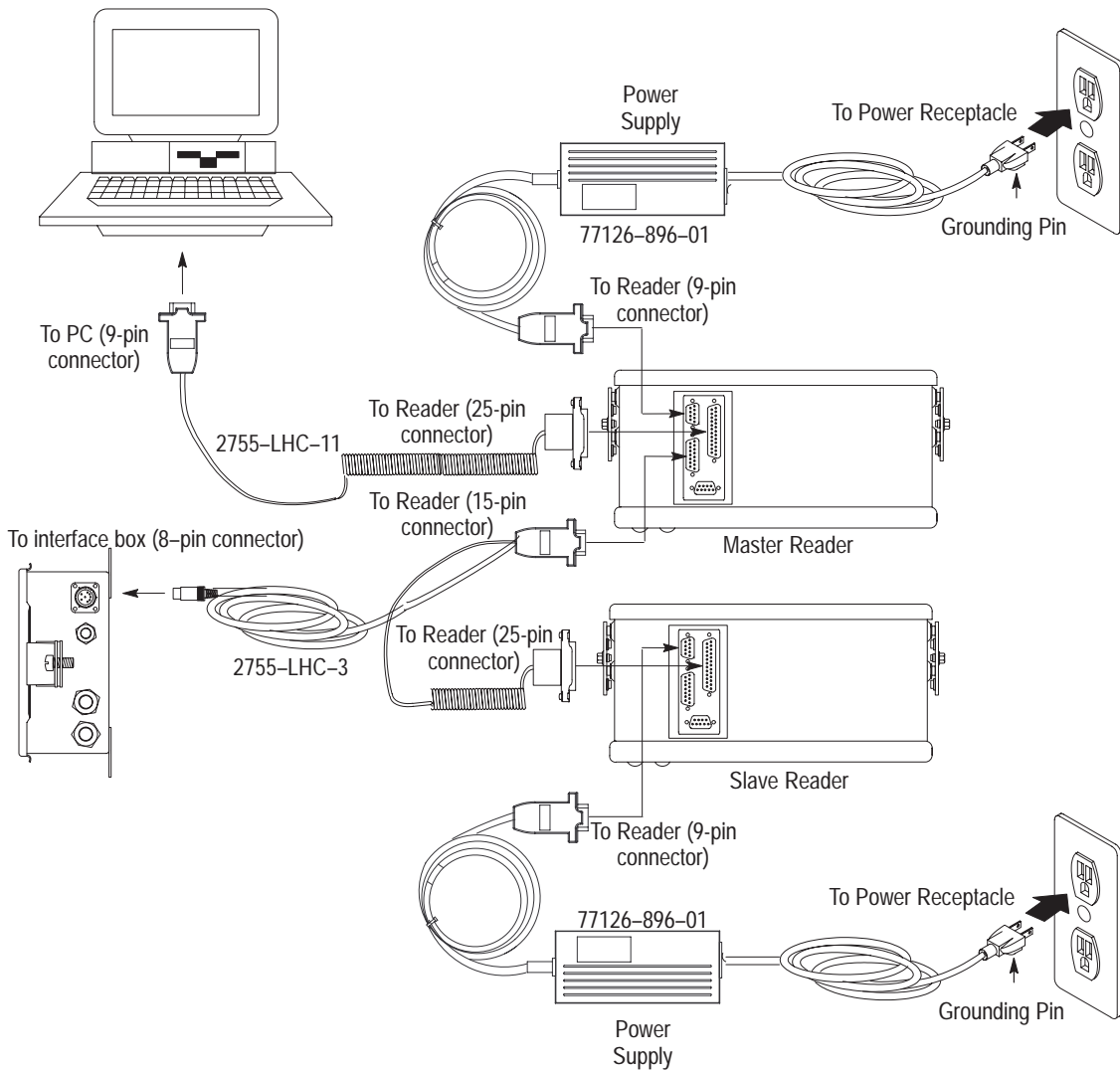



ATTENTION: Before connecting power, make sure that the 3 power leads from the interface box power cord are connected to their proper locations on the power terminal block and grounding posts *inside the interface box case*. A domestic and a European example are shown in the following illustration. Make sure that the interface box is connected to an ac source per local/regional electrical codes.

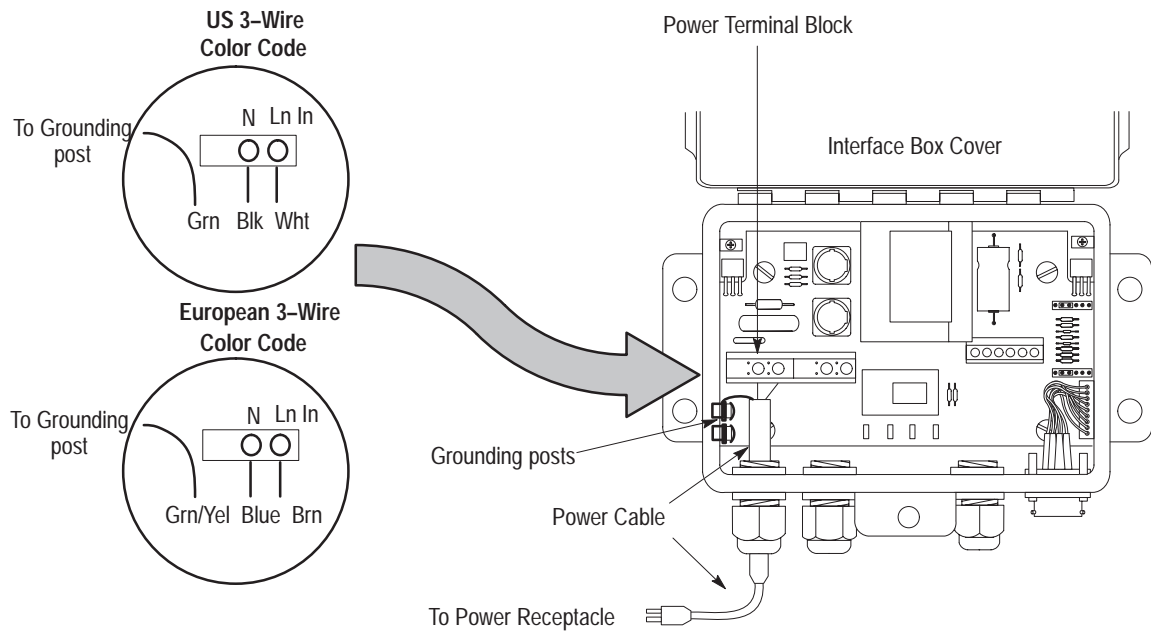

ATTENTION: Before applying power to the interface box, make sure the voltage selector switch is in the correct position.

10. Mount the interface box. The dimensions of the interface box are shown in Appendix A.

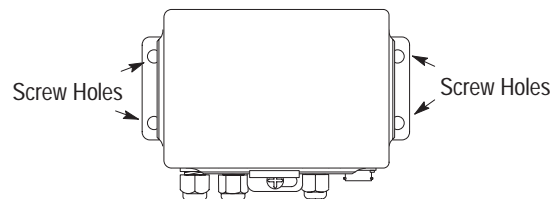

11. Connect the interface box to the power receptacle supplying 100/240V ac.
12. Connect each power supply cable to each power supply and to the power receptacle supplying 100/240V ac.

When power is applied to each reader, the green LED flashes on and off, then the red LED turns on and remains on. A beep is emitted from each reader as well, indicating the reader has power. Scan beams are also emitted from each reader.

When power is applied to the interface box, the green 12V LED turns on and remains on.

Maintenance and Troubleshooting

This chapter provides information on how to maintain and troubleshoot your StrataScan hardware. Items include:

- cleaning the scan window
- troubleshooting the readers
- contacting Technical Support



CAUTION!: Before cleaning window, make sure that power to the reader is off. Failure to disconnect power may cause exposure to laser light.

Cleaning the Scan Window

Carefully clean the window by first removing loose particles of dirt with canned ultra-filtered air. Then use an *optical quality cloth* moistened with an *optical quality cleaning fluid for plastic lenses*. Wipe the window in a single direction, turning the cloth to a clean side after each wipe (don't wipe cloth back and forth across window). Do not leave streaks.



ATTENTION: Do not use abrasive materials such as disposable wipes and facial tissue. Do not use solvents like alcohol or acetone. These materials will damage the window and the finish on the reader.



ATTENTION: The reader has no serviceable parts. Do not open the housing of the reader.

Troubleshooting the Readers

The following table provides a list of the most common operating problems, probable causes, and corrective actions.

Problem	Possible Cause (s)	Corrective Action
No blinking Green LED	No power	Check transformer, outlet and power strip.
No Motor Spin	No power	
Blinking Green LED	Motherboard problem	Contact an Allen-Bradley service representative.
No Motor Spin	1. Motherboard problem 2. Reader is in motor failure condition.	
LED's toggle back and forth and unit produces "razzes"	1. Motor may be defective.	Contact an Allen-Bradley service representative ^① .
	2. Too much vibration or jarring	Isolate reader from vibration.
Reader makes "razz" tone during power-up	Decode module failed communications with the motherboard	Contact an Allen-Bradley service representative.
Power-up OK, reads OK but does not communicate properly to host.	COM Port at host not working or is configured improperly	As a quick test, put reader into Program mode through StrataScan software. If successful, the RECEIVE and TRANSMIT lines are working ^② .
Does not communicate properly to host	Cable not connected to the proper COM Port	Check cable connections.

^① If reader is in an environment subject to much vibration or sudden jarring, the motor may experience a motor failure condition temporarily. The unit will recover after the external stimulus has disappeared.

^② If the reader is not configured for host RTS/CTS, this test is enough to verify that the reader, communication cable and host are all working properly. When the reader is configured for host RTS/CTS, temporarily disable this function in the reader and try the quick test above. If the reader works with RTS/CTS disabled, and fails when RTS/CTS is re-enabled, there is a problem with either the RTS or CTS line or both. Contact an Allen-Bradley service rep.

Table continued on the next page.

Problem	Possible Cause (s)	Corrective Action
Reader does not enter Program mode	<ol style="list-style-type: none"> 1. Host COM Port not working properly 2. Wrong COM Port 3. Communication cable is not connected properly or is defective 	<ol style="list-style-type: none"> 1. Check to see if cable connection to COM Port is correct. 2. Make sure COM Port selection in StrataScan configuration software is correct.
Host receiving data but data does not look correct	Interface format incompatibility	Check that the reader and host are configured for the same interface format.
Characters are being dropped	No inter-character delay	Add some inter-character delay to the transmitted output. Program this into reader through the StrataScan configuration software.
Unit powers up properly and lasers come on, but still does not read.	Reading a particular symbology that has been deselected.	Verify that the bar code being read is selected.
	Reader has been programmed for a character length lock or for a minimum length and the bar code being read does not satisfy the programmed criteria.	Verify that bar code being read falls into the criteria.
	Reader has been configured for Package Detect Support, but is not receiving a Package Detect signal	Verify that the device used to generate the package detect input is working properly.
	Reader reads and transmits a bar code, but the reader hangs up (green LED comes on and stays on) after the first read. The reader is configured to support some form of host handshaking, but is not receiving the signal. If the reader is setup to support ACK/NAK, RTS/CTS, XON/XOFF or D/E.	Verify that host is supporting the handshaking properly.
	Package Detect is selected and the Package Detect signal seems to be generated properly, but the reader is not reading.	Read duration may be set too short. Read duration can be set from 100 msec to 8.9 sec. Make sure that read duration time is set correctly for the particular application.
	Reader reads and transmits, but the data is not correct at the host.	Verify that reader's data format matches that required by the host. Make sure that the reader is connected to the proper host port. As a rule of thumb, if configurations can be downloaded successfully to the reader, the cable and port setup are physically working. The only exception is with RTS/CTS, which is not used during the download sequence.

Table continued on the next page.

Problem	Possible Cause (s)	Corrective Action
Cannot read bar code ^③	<ol style="list-style-type: none"> 1. Print quality of the bar code is suspect. 2. The aspect ratio of the bar code is out of tolerance. 3. The bar code may have been printed incorrectly. 	<p>To verify the basic operation of the reader, configure the reader with the standard default settings. To do this, enter the reader's Program Mode from StrataScan's main menu. Press Enter at the Configuration screen menu choice. From the Configuration screen, press F5 to download the configuration to the reader. The reader is now setup to read all common symbologies with a minimum of 4 characters. Try reading a typical UPC bar code on a typical office supply product or food product. If the reader reads the bar code presented, the basic operation of the reader is verified. The problem is within the reader setup. Determine how the reader should be configured. Contact an Allen-Bradley service rep. for help. If not possible, then make sure all settings are correct.</p>
DOS error code: # 68 – Device unavailable	<p>This error occurs when a file or COM Port is accessed (that according to the system) does not exist. Normally this occurs when the COM Port is used that is attached to a wrong type of peripheral. Or when there is a problem with the COM Port itself.</p>	<p>Try using another COM Port, if available. If all else fails, reboot the system.</p>
DOS error code: # 24 – Device timeout	<p>This error occurs when the host did not receive information from the I/O device within a predetermined amount of time.</p>	<p>Check that the reader is connected to the correct COM Port and verify that the COM Port is working correctly. If all else fails, reboot the system.</p>

^③ Many other scenarios can cause reading problems. If problems persist, contact an Allen-Bradley service representative.

Technical Support Services

If you have any questions about the StrataScan Bar Code Reader, please consult this manual first. If you can't find the answer, contact your local Allen-Bradley support office or distributor.

Specifications

This appendix provides the specifications and dimensions for the:

- StrataScan Bar Code Readers (Catalog Nos. 2755-LHR-5B, 2755-LHR-3C, 2755-LHR-5C and 2755-LHR-5BX1)
- interface box (Catalog No. 2755-LHB-1)
- replacement power supply (Replacement Part No. 77126-896-01)
- replacement mounting brackets for readers (Replacement Part Nos. 77126-898-01 and 77126-898-02)

StrataScan Bar Code Reader Specifications

The following table provides the specifications for the StrataScan Bar Code Readers (Catalog Nos. 2755-LHR-5B, 2755-LHR-3C, and 2755-LHR-5C).

Description	Specification			
	Catalog No. 2755-LHR-5B	Catalog No. 2755-LHR-3C	Catalog No. 2755-LHR-5C	Catalog No. 2755-LHR-5BX1
Scan Speed	5250 scan lines per second	3360 scan lines per second	5600 scan lines per second	7350 scan lines per second
Number of Scan Lines	75 interlocking lines	48 interlocking lines	80 interlocking lines	80 interlocking lines
Operating Current	2.5 A	2.8 A	3.59 A	3.59 A
Power Requirements	Input + 12V dc \pm 4% regulated @ 480 mA with 200 mV p-p maximum ripple			
Scan Pattern	Omnidirectional			
Tilt	360°			
Skew Tolerance	\pm 60°			
Pitch Angle	\pm 60°			
Decode Depth of Field	36 in. to 76 in. (91 cm to 193 cm)			
Minimum Element Width	Refer to StrataScan Bar Code Readers User Manual, Pub. No. 2755-6.13			
Print Contrast Minimum	35% reflectance difference			
Output Wavelength	675 nm nominal			
Ambient Light Immunity				
Artificial Lighting	400 ft candles (fluorescent, incandescent, and mercury vapor)			
Soft Outdoor	1800 ft candles			
Housing Rating	NEMA 12 steel case			
Operating Shock	100g for 1 ms			
Electrostatic Discharge	15 kv IEC 801-2 level 4			
Operating Temperature	32°F to 104°F (0°C to 40°C)			
Storage Temperature	-40°F to 140°F (-40°C to 60°C)			
Humidity	5% to 95% noncondensing			
CDRH Class	II			
Agency Certification	<ul style="list-style-type: none"> •cUL listed •UL listed •CE marked for all applicable directives. •IEC class I 			

Interface Box Specifications

Description	Specification
Catalog Number	2755-LHB-1
Electrical Characteristics	
Input Voltage	UL and cUL 100, 115, or 230V ac at 50 Hz, 60 Hz 6.1 A
Relay	CE 115, 230V ac at 50 Hz, 60 Hz 5.1A
Output for Sensor	Triac, 5 A EEA Countries 6 A USA and Canada
Operating Temperature	+12V dc @ 200 mA
Humidity	32°F to 122°F (0°C to 50°C)
Agency Certification	5% to 95% noncondensing
	<ul style="list-style-type: none"> • cUL listed • UL listed • CE marked for all applicable directives.

Power Supply Specifications

Description	Specification
Replacement Part Number	77126-896-01
Input Voltage	100 to 240V ac
Input Frequency	50 to 60 Hz
Output Voltage	+12 V
Vibration	
Acceleration	$\pm 7.35 \text{ m/sec}^2$
Direction	x, y, and z axis
Operating Temperature	41°F to 113°F (5°C to 45°C)
Storage Temperature	-13°F to 185°F (-25°C to 85°C)
Operating Humidity	20%-80% non-condensing
Storage Humidity	5%-90% non-condensing
Agency Certification	<ul style="list-style-type: none"> • CSA certified • UL Recognized • CE marked for all applicable directives

StrataScan Bar Code Reader Dimensions

Reader dimensions are shown below:

Catalog Number 2755-LHR-5B

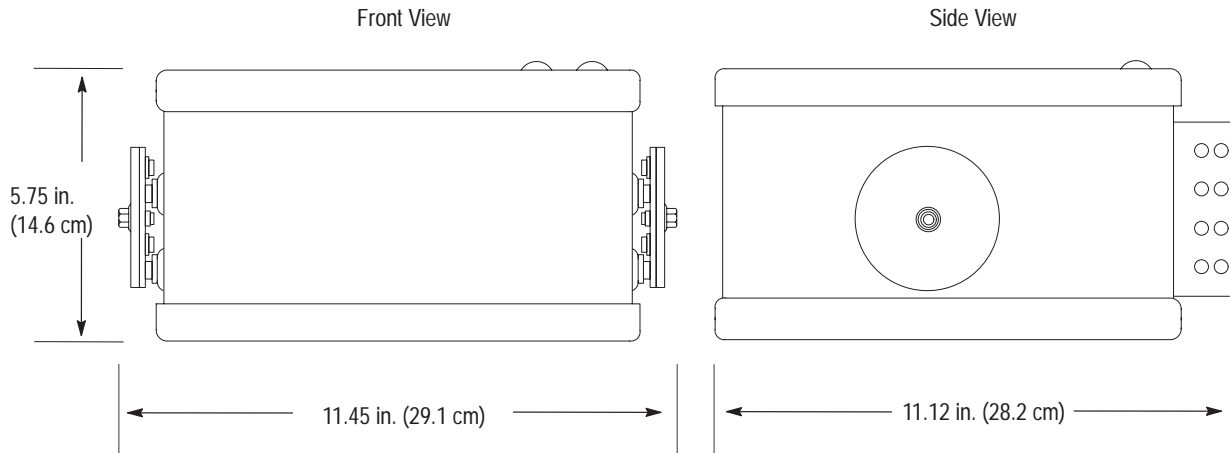

Catalog Numbers 2755-LHR-3C, -5C and -5BX1

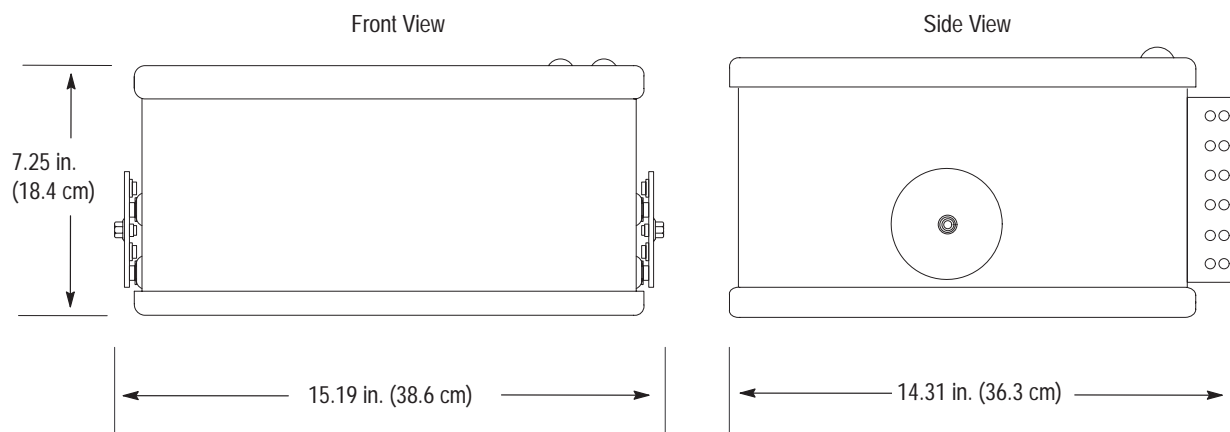

Interface Box Dimensions

Dimensions for the interface box are shown below:

Catalog Number 2755-LHB-1

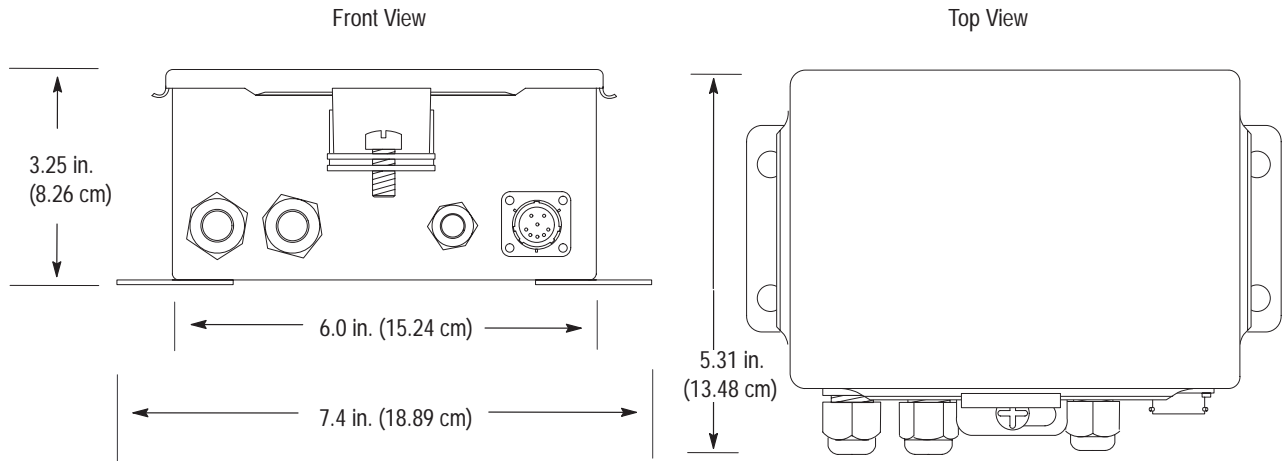

Power Supply Dimensions

Power supply dimensions are shown below:

Replacement Part Number 77126-896-01

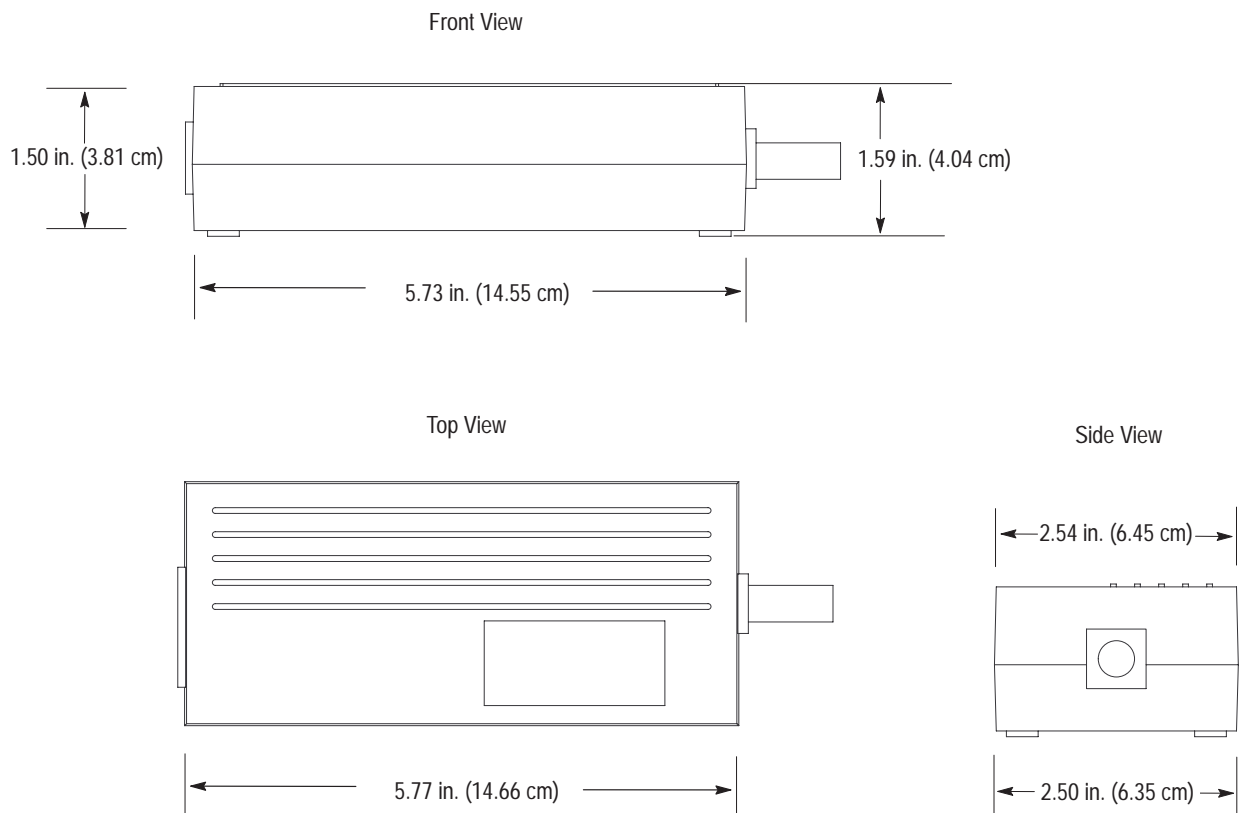

Mounting Bracket Dimensions

Mounting bracket dimensions for all StrataScan readers are shown starting below:

Replacement Part Number 77126-898-01 (for reader 2755-LHR-5B)

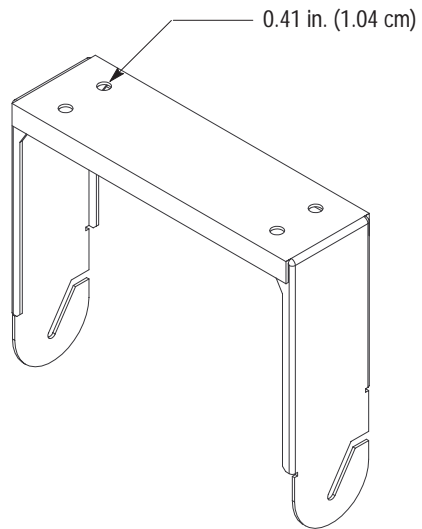

Side View

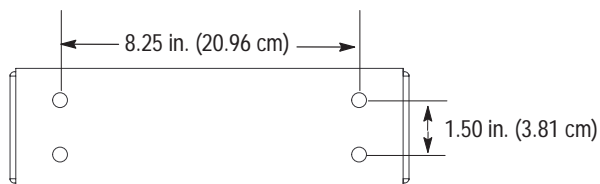

Top View

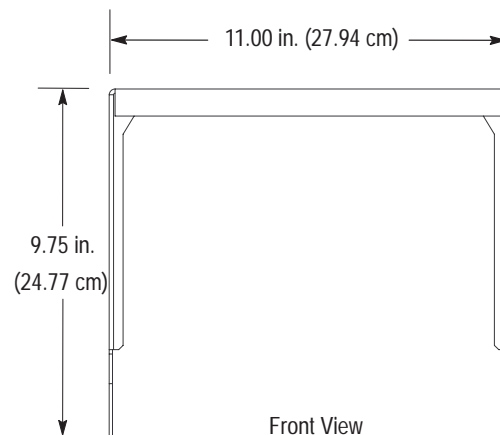

Front View

Replacement Part Number 77126-898-02 (for readers 2755-LHR-3C, -5C and -5BX1)

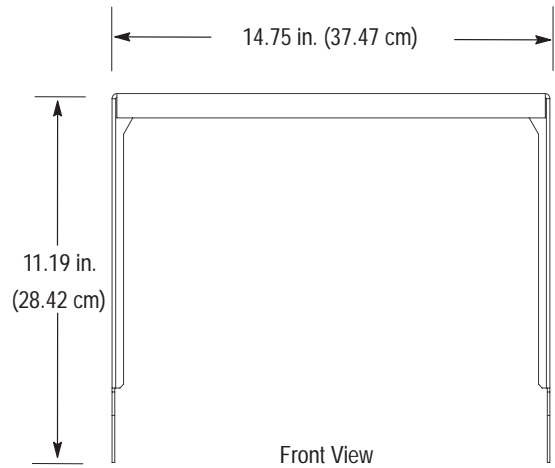
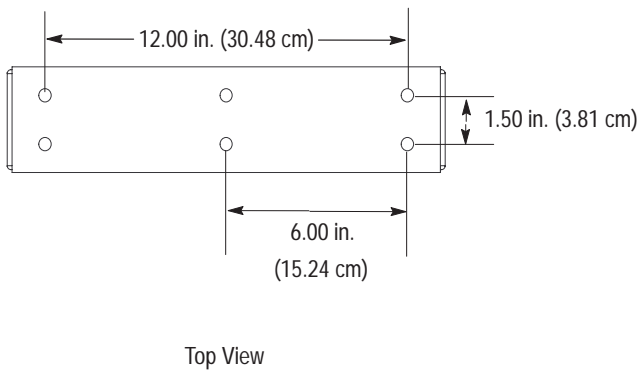
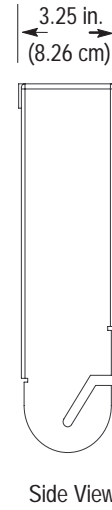
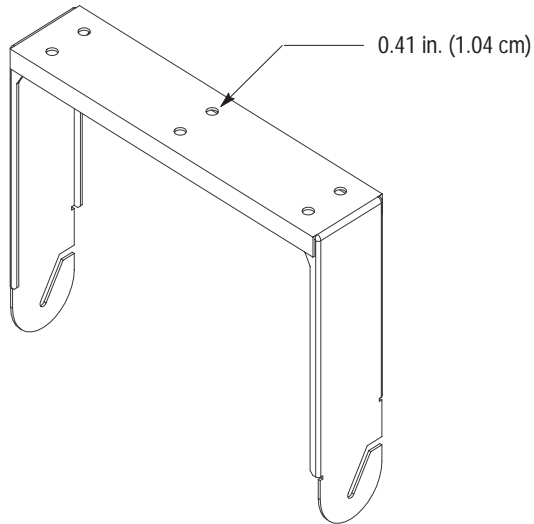

Cable Pinouts

This appendix provides the cable pinouts for the readers, interface box, power supply, and assorted cables.

Reader Pinouts

The following sections provide the pinouts for the StrataScan Bar Code Readers (Catalog Nos. 2755-LHR-5B,-3C, -5C and 5BX1).

RS-232 Port

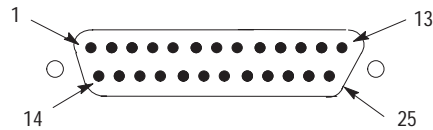

Pin	Signal	Function
1	GND	Chassis ground
2	RXD	Reader receives data from the host device.
3	TXD	Reader transmits data to the host device.
4	CTS Input	Reader is requesting data from the host device.
5	RTS Output	Host device is requesting data from the reader.
6	Not Used	Pin not used.
7	GND	Signal ground
8	Not used	Pin not used.
9	RXB-	Reader receives data from the host device (RS-422).
10	RXA+	Reader receives data from the host device (RS-422).
11	TXY+	Host transmit data to the reader (RS-422).
12	TXZ-	Host transmit data to the reader (RS-422).
13	GND	Ground
14	GND	Ground
15	Not Used	Pin not used.
16	Not Used	Pin not used.
17	Not Used	Pin not used.
18	Not Used	Pin not used.
19	Not Used	Pin not used.
20	DTR Input	The data terminal is ready.
21	Not Used	Pin not used.
22	Not Used	Ground
23	Not Used	Pin not used.
24	Not Used	Pin not used.
25	GND	Ground

Interface Box Port

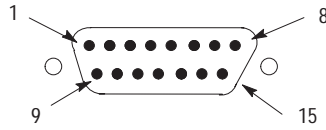

Pin	Signal	Function
1	RXD	Reader receives data from the interface box.
2	CTS	Reader is requesting data from the interface box.
3	Not Used	Pin not used.
4	Not Used	Pin not used.
5	Triac+	Controls the triac input.
6	Sensor+	Pin that provides the sensor's object detected input signal.
7	Sensor Alarm+	Pin that provides the sensor's optional marginal sensing alarm input signal.
8	Not Used	Pin not used.
9	TXD	Reader transmit data to the interface box.
10	RTS	Interface box is requesting data from the reader.
11	GND	Signal ground
12	Not used	Pin not used.
13	Triac-	Controls the triac input.
14	Sensor-	Pin that provides the sensor's object detected input signal.
15	Sensor Alarm-	Pin that provides the sensor's optional marginal sensing alarm input signal.

Power Supply Port

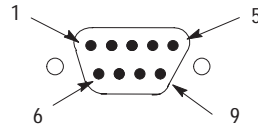

Pin	Function
1	12V dc input power to the reader.
2	12V dc input power to the reader.
3	Earth ground
4	Power ground
5	Power ground
6	12V dc input power to the reader.
7	12V dc input power to the reader.
8	Power ground
9	Power ground

Hand-Held Port Pinouts

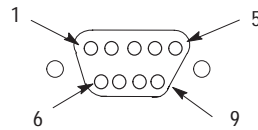

Pin	Signal	Function
1	Start of Scan	Synchronizes decode logic with the scanner.
2	Digitized Bar Pattern	Input receives a series of pulses proportional to the widths of bar code being scanned from the hand-held scanner.
3	Decode LED	Controls green decode LED on hand-held scanner.
5	Trigger Switch	Connected to trigger switch of the hand-held scanner
6	Enable	Signal output to power up the hand-held scanner, turn on the laser, and turn on the scanning motor.
7	Ground	
8	Shield ground	
9	Power	+5V dc to power hand-held scanner

Note: Place a female contact in pin 4 of the 9-pin hand-held connector.

Interface Box Pinouts

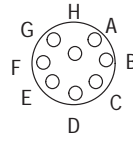

Pin	Signal	Function
A	Triac+	Controls the triac input.
B	Triac-	Controls the triac input.
C	Sensor+	Provides the sensor's object detected input signal.
D	Sensor-	Provides the sensor's object detected input signal.
E	Sensor Alarm	Provides the sensor's optional marginal sensing alarm input signal.
F	Sensor Alarm	Provides the sensor's optional marginal sensing alarm input signal.
G	Not Used	Pin not used.
H	Not Used	Pin not used.

Power Supply Pinouts

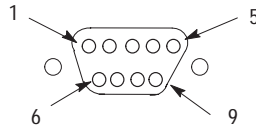

Pin	Function
1	12V dc input power to the reader.
2	12V dc input power to the reader.
3	Earth ground
4	Power ground
5	Power ground
6	12V dc input power to the reader.
7	12V dc input power to the reader.
8	Power ground
9	Power ground

Reader Master/slave Cable Pinouts

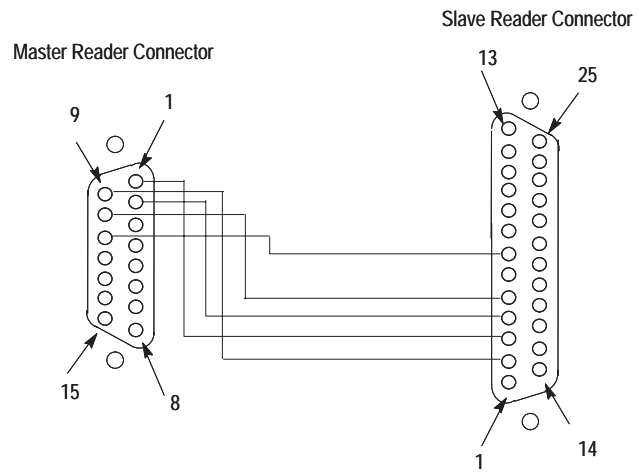

Master Reader Connector (15-Pin) Pin Number	Signal from Master Reader	Slave Reader Connector (25-Pin) Pin Number
1	RXD (input)	3
2	CTS (output)	4
9	TXD (output)	2
10	RTS (input)	5
11	GND	7

Reader Null Modem Cable Pinouts

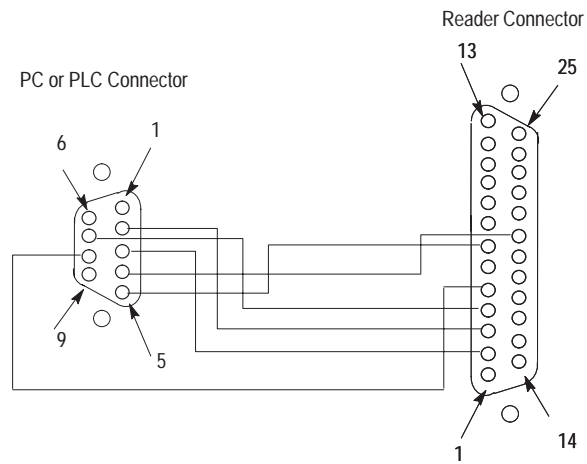

PC or PLC Connector (9-Pin) Pin Number	Signal from Reader	Reader Connector (25-Pin) Pin Number
3	RS-232 Receive	2
2	RS-232 Transmit	3
7	CTS (input)	4
8	RTS (output)	5
5	GND	7
4	DTR (input)	20

Interface Box Cable Pinouts

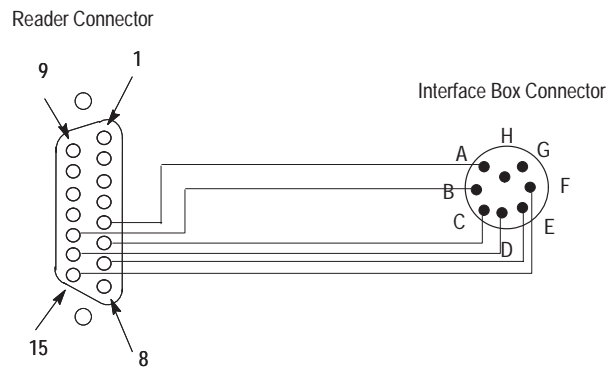

Reader Connector (15-Pin) Pin Number	Signal from Reader	Interface Box Connector (8-Pin) Pin Number
5	Triac+	A
13	Triac-	B
6	Sensor+	C
14	Sensor-	D
7	Sensor alarm+	E
15	Sensor alarm-	F

Interface Box Master/slave Cable Pinouts

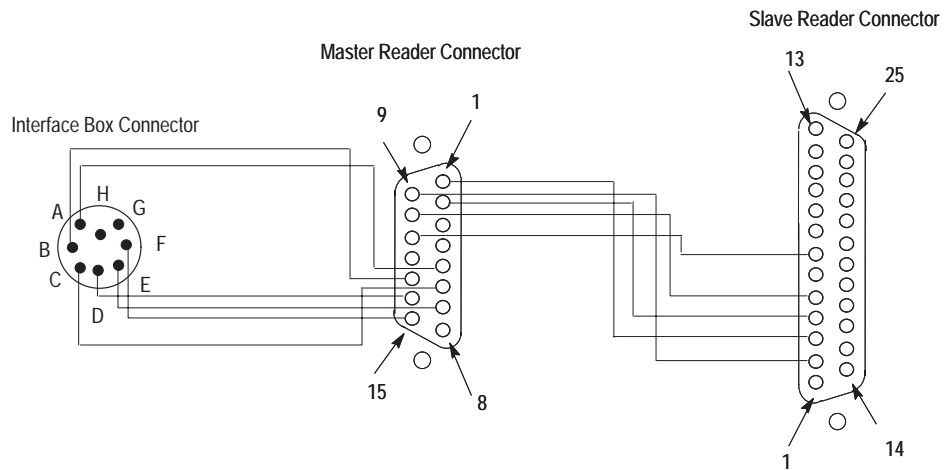

Interface Box Connector (8-Pin) Pin Number	Master Reader Connector (15-Pin) Pin Number	Signal from Master Reader	Slave Reader Connector (25-Pin) Pin Number
No connection	1	RXD (input)	3
No connection	2	CTS (output)	4
A	5	Triac+	No connection
C	6	Sensor+	No connection
E	7	Sensor alarm+	No connection
No connection	9	TXD (output)	2
No connection	10	RTS (input)	5
No connection	11	GND	7
B	13	Triac-	No connection
D	14	Sensor-	No connection
F	15	Sensor alarm-	No connection

European Union Directives

This appendix provides information regarding:

- compliance to European Union Directives
- declaration of conformity

Compliance to European Union Directives

If this product has the CE mark, it meets applicable standards required for installation within the European Union and EEA regions. It has been designed and tested to meet the following directives.

This product is tested to meet Council Directive 89/336/EEC Electromagnetic Compatibility (EMC) and the following standards, in whole or in part, documented in a technical construction file:

- EN 50081-2
EMC – Generic Emission Standard, Part 2 – Industrial Environment
- EN 50082-2
EMC – Generic Immunity Standard, Part 2 – Industrial Environment

This product is intended for use in an industrial environment.

Low Voltage Directive

This product is tested to meet Council Directive 73/23/EEC Low Voltage, by applying the safety requirements of EN 61131-2 Programmable Controllers, Part 2 – Equipment Requirements and Tests.

For specific information required by EN 61131-2, see the appropriate sections in this publication, as well as the following Allen-Bradley publications:

- Industrial Automation Wiring and Grounding Guidelines For Noise Immunity, publication 1770-4.1
- Guidelines for Handling Lithium Batteries, publication AG-5.4
- Automation Systems Catalog, publication B111

Declaration of Conformity

Below is a copy of the Declaration of Conformity for the StrataScan Bar code Readers (Catalog Numbers 2755-LHR-5B, -3C, -5C, and -5BX1)

DECLARATION OF CONFORMITY

This Declaration of Conformity is suitable to the European Standard EN 45014, "General criteria for supplier's declaration of conformity." The basis for the criteria has been found in international documentation, particularly in: ISO/IEC Guide 22, 1982, "Information on manufacturer's declaration of conformity with standards or other technical specifications."

Allen-Bradley liability under this declaration is limited to that set forth in the current Allen-Bradley publication 6500, Terms and Conditions of Sale as well as similar publications from Allen-Bradley affiliates doing business in the European Community.

Applied Council Directive(s):
Electromagnetic Compatibility Directive (EMC) 89/336/EEC,
Low Voltage Directive 73/23/EEC,
and amending directives 91/263/EEC, 92/31/EEC, 93/68/EEC

<p>We, Manufacturer: Allen-Bradley Company, Inc. 1201 South 2nd Street Milwaukee, WI 53204 USA</p>	<p>Authorized Representative in the Community (and location of Responsible Person):</p>	<p>Rockwell Automation, subsidiary of Rockwell International GmbH Düsselberger Str. 15 D-42781 Haan, Germany</p>
---	--	---

declare under our sole responsibility that the product(s) (name, type/model, batch/serial number):

Holographic Bar Code Readers including the Bulletin 2755-LHR-5 and -LHR-3 family of bar code readers.

to which this declaration relates is in conformity with the relevant provisions of the following standard(s) or other normative document(s):

EN 55 022 : 1993
EN 50 082-1 : 1992 (IEC 1000-4-2 : 1995, IEC 1000-4-3 : 1995, IEC 1000-4-4 : 1995)
EN 60 950 : 1992 / A1 : 1993 / A2 : 1994 / A3 : 1995
EN 60 825-1 : 1994 / A11:1996

Test Information is maintained at:
Allen-Bradley Company, Inc.
1201 South Second Street
Milwaukee, WI 53204 USA

Year of CE Marking (Low Voltage Directive): 1997

We, the undersigned, hereby declare that the product(s) specified above conforms to the listed directive(s) and standard(s).

Authorized Representative in the Community through its Responsible Person

Signature:



Signature:

i.V. 

Full Name: Robert Gardiner
 Position: Manager, Quality Engineering
 Date: Oct. 29, 1997

Full Name: Viktor Schiffer
 Position: Engineering Manager
 Date: Oct. 30, 1997

Numbers

15-pin connector, 4-5, 4-9, 4-12
 25-pin connector, 4-5, 4-9, 4-12
 8-pin connector, 4-5, 4-12
 9-pin connector, 4-5, 4-9

A

accessories, 2-9
 ANSI Standards, 3-2
 available symbologies, 2-5

B

Bar code width, 3-5
 blinking green LED, 5-2

C

cannot scan bar code, 5-4
 characters being dropped, 5-3
 cleaning scan window, 5-1
 Compliance to European Union Directives, C-1
 connector
 15-pin, 4-5, 4-12
 25-pin, 4-5, 4-12
 8-pin, 4-5, 4-12
 9-pin, 4-5, 4-9
 contacting Allen-Bradley for assistance, 5-5
 Contents of this Manual, P-1
 Conventions Used in this Manual, P-2

D

Declaration of Conformity, C-2
 Decoding, 2-5
 Designing Your System, 3-1
 device timeout, 5-4
 device unavailable, 5-4
 dimensions
 interface box, A-5
 mounting bracket, A-6, A-7

power supply, A-5
 reader, A-4

Disc Operation, 2-3
 distance from front of scanner, 3-5
 distance from reader to another device, 4-2, 4-4, 4-8, 4-10
 distances
 RS232, 4-2, 4-4, 4-8, 4-10
 RS422, 4-2, 4-4, 4-8, 4-10
 DOS error codes, 5-4

F

features, reader, 2-1

G

green LED flashing, 4-3

H

Hardware Features
 interface box, 2-4
 overview, 2-1
 Holographic Scanning Disc, 2-2
 host handshaking problems, 5-3

I

Installing mounting bracket, 4-2
 Installing Your Hardware, 4-1
 Intended Audience, P-2
 interface box, 4-5, 4-6
 dimensions, A-5
 features, 2-4
 power connections, 4-7, 4-13
 sensor connections, 4-5
 specifications, A-3
 interface format incompatibility, 5-3

L

laser caution symbol, 2-7

M

maintaining the reader, 5-1
 manual contents, P-1
 manual conventions, P-2
 Master/slave Installation (With Interface Box), 4-10
 Master/slave Installation (Without Interface Box), 4-8
 master/slave option, 4-10
 Maximum scan width, 3-5
 Minimum bar code width, 3-5
 mounting bracket, dimensions, A-6, A-7
 Mounting bracket installation, 4-2
 mounting interface box, 4-6

N

No blinking green LED, 5-2
 no inter-character delay, 5-3
 No motor spin, 5-2
 null modem cable connection, 4-3

P

Pitch, 3-4
 PLC or PC to Reader, 4-2
 PLC or PC to reader and interface box, 4-4
 poor communication to host, 5-2
 power connections, interface box, 4-7, 4-13
 power supply
 connection to reader, 4-3
 dimensions, A-5
 specifications, A-3
 power terminal block, 4-7, 4-13
 Preface, P-1
 Print Quality Guideline, 3-2

Q

Quiet Zone, 3-2

R

razz tone, 5-2
 Read Range, 3-5
 reader
 accessories, 2-9
 connection to second reader, 4-9, 4-12
 dimensions, A-4
 does not enter Program mode, 5-3
 features, 2-1
 introduction to, 1-1
 LEDs, 2-3
 maintaining, 5-1
 safety information, 2-6
 Scan Beam Options, 2-8
 specifications, A-2
 symbolologies used by, 2-5
 troubleshooting, 5-2
 reader beep, 4-3
 red LED on, 4-3
 Related Publications, P-2
 Required Tools and Equipment, 1-1
 RS232
 distances, 4-2, 4-4, 4-8, 4-10
 installations, 4-2
 RS422
 distances, 4-2, 4-4, 4-8, 4-10
 installations, 4-2
S
 Safety Information
 overview, 2-6
 warning label, 2-7
 Scan Beam Options, 2-8
 Scan width, maximum, 3-5
 scan window cleaning, 5-1
 scanner system
 determining symbol height and length, 3-2
 determining symbol quality, 3-2
 setup goals, 3-1
 scanners, specifications, A-2
 scanning problems, 5-3
 sensor leads, 4-5
 Setup Goals, 3-1

setup sequence, master/slave, 4–10

Skew, 3–4

Specifications, A–1

specifications

interface box, A–3

power supply, A–3

reader, A–2

Strata, scan beam, 2–8

symbol

height and length, 3–2

orientation, 3–3

quality, 3–2

Tilt, Pitch, and Skew, 3–3

Symbol Orientation, overview, 3–3

symbologies, 2–5

T

Technical Support, 5–5

Technical Support Services, P–2

terminal block, sensor, 4–5

Tilt, 3–3

Troubleshooting the reader, 5–2

U

unpacking shipping boxes, 1–2



Rockwell Automation helps its customers receive a superior return on their investment by bringing together leading brands in industrial automation, creating a broad spectrum of easy-to-integrate products. These are supported by local technical resources available worldwide, a global network of system solutions providers, and the advanced technology resources of Rockwell.

Worldwide representation.



Argentina • Australia • Austria • Bahrain • Belgium • Bolivia • Brazil • Bulgaria • Canada • Chile • China, People's Republic of • Colombia • Costa Rica • Croatia • Cyprus • Czech Republic • Denmark • Dominican Republic • Ecuador • Egypt • El Salvador • Finland • France • Germany • Ghana • Greece • Guatemala • Honduras • Hong Kong • Hungary • Iceland • India • Indonesia • Iran • Ireland • Israel • Italy • Jamaica • Japan • Jordan • Korea • Kuwait • Lebanon • Macau • Malaysia • Malta • Mexico • Morocco • The Netherlands • New Zealand • Nigeria • Norway • Oman • Pakistan • Panama • Peru • Philippines • Poland • Portugal • Puerto Rico • Qatar • Romania • Russia • Saudi Arabia • Singapore • Slovakia • Slovenia • South Africa, Republic of • Spain • Sweden • Switzerland • Taiwan • Thailand • Trinidad • Tunisia • Turkey • United Arab Emirates • United Kingdom • United States • Uruguay • Venezuela

Rockwell Automation Headquarters, 1201 South Second Street, Milwaukee, WI 53204-2496 USA, Tel: (1) 414 382-2000 Fax: (1) 414 382-4444

Rockwell Automation European Headquarters, Avenue Hermann Debroux, 46, 1160 Brussels, Belgium, Tel: (32) 2 663 06 00, Fax: (32) 2 663 06 40

Rockwell Automation Asia Pacific Headquarters, 27/F Citicorp Centre, 18 Whitfield Road, Causeway Bay, Hong Kong, Tel: (852) 2887 4788, Fax: (852) 2508 1846

World Wide Web: <http://www.ab.com>