



**SHOPPING TROLLEY
MODEL: 80 L**



USER'S MANUAL

LIST OF CONTENTS

I		Introduction – general information	p.2
	1	Brand	p.2
	2	From idea to final product.....	p.2
II		Shopping trolley Rabtrolley® MINI 80 L.....	p.3
	1	General information.....	p.3
	2	Features of the Rabtrolley® MINI 80L.....	p.4
	2.1	Esthetics of performance ↔ brainy project + plastics.....	p.4
	2.2	Increased load capacity ↔ large capacity basket + shelf for bottles.....	p.4
	2.3	Easiness to maneuver ↔ high-quality wheels.....	p.4
	2.4	Eco-friendliness ↔ ecological product.....	p.5
	2.5	Security warranty ↔ conformity to standards.....	p.5
	2.6	Traceability ↔ barcode label + compatibility with RFID technology.....	p.5
	3	Versions of Rabtrolley® MINI 80 L.....	p.6
	3.1	MINI 80 L Basic.....	p.6
	3.2	MINI 80 L Basic EX.....	p.6
	3.3	MINI 80 L Bio.....	p.6
	2.4	MINI 80 L Eko.....	p.7
	2.5	MINI 80 L Glamour.....	p.7
	2.6	MINI 80 L Flock.....	p.7
III		Information for users.....	p.8

I . Introduction – general information:

1. Brand

Rabtrolley® is a brand of Rabugino Sp. zo.o. created for the purpose of commercialization of the modern innovative line of shopping trolleys for the retail trade sector.

We are the producer of shopping trolleys having over 30-years' experience in the area of plastics processing.

Through the market research and the analysis of the collected data realized in 2 years' time, we have created the product of the highest quality that has unique features, including first of all the functionality, comfort of use and stylish design - the result of the work of the Italian designer's Pino Spagnolo's studio.

Our efforts were recognized and honored with the prestigious statuette and on May 23th 2013 the line of Rabtrolley® shopping trolleys received Złoty Paragon (The Golden Receipt) - The Award of Polish Buyers 2013 in the category of "Creativity & Innovation". The award was given with partnership of Polish Ministry of Economy. While on January 20th 2014 the shopping trolley Rabtrolley® Midi 160 I. won the silver award in the category 'Shop Ideen' at the finals of the Top Produkt Handel Competition 2014 organized by the Handels Journal, the largest monthly magazine for the FMCG industry in Germany.



The production of trolleys is entirely realized in Poland, in Grodzisk Mazowiecki (40 km from Warsaw).

2. From idea to final product

Rabtrolley® "the new generation of trolleys "

Why „the New Generation”? Our shopping carts are innovative and more functional than others available on the market. A brand new design, unbeatable quality, functionality, easiness of keeping clean and care for the environment (recycling) these are the assets of Rabtrolley® trolleys.

Why plastic? The use of plastic gives us the opportunity to make our trolleys light, colorful and pleasing to the sight, it lets the Client personalize the product in an exceptional way. In the meantime the plastic is a very reliable material that does not corrode. Our trolleys are environmentally friendly because for their production we use recycled raw materials, moreover the plastic from used Rabtrolley® trolleys can be recovered and used to produce new ones.

Thanks to the plastic, the shopping trolleys Rabtrolley® Mini 80 I. are compatible with RFID technology, which through electronic tags stuck on the products can accelerate and facilitate cash service in the stores and reduce its costs.

Since a few years it is possible to find first models of plastic shopping trolleys in the markets, but unfortunately not always these first experiences have been positive, and this fact still influences the supremacy of the wire trolleys on the plastic ones. However plastic can win the competition with metal only when there is the appropriate design and solid knowledge standing behind. Through the 30-years' experience of Rabugino in the plastic processing sector, Rabtrolley® bases on its deep know-how thereby resulting into obtaining products with unique strengths.

II. Shopping trolley Rabtrolley® MINI 80 L



1. General informations

The shopping trolley Mini 80 L. made entirely of plastic owns the unique project created by studio of the Italian designer Pino Spagnolo.

The Rabtrolley® Mini 80L has been constructed as an intelligent alternative for a traditional shopping basket. Handiness in use, big load capacity of the basket - 80L net (40 kg) and comfortable shelf for bottles(15 kg) will surely have influence on the rise of turnover in the shop.

Compact dimensions and excellent maneuverability of the Rabtrolley® Mini 80L increase its attractiveness, especially in small stores.

Each version of the trolley can be optionally equipped with a coin-lock system. For our products we use locking systems of the company Systec. It is possible to order such a system for any currency you need.

The castors used in the Rabtrolley® MINI 80L have the diameter of Ø 75 mm and are made by the company TENTE. In the standard equipment wheels have a metal fork.

The model MINI 80L is produced in six versions: Basic, Basic Ex, Eko, Bio, Glamour and Flock. Each trolley, besides its standard colours, can be realized in a specific colour requested by the Customer, it can be assembled with back and shelf for bottles in different colours as well. The Rabtrolley® Mini 80L can be also personalized with a logo printed on a label or engraved in plastic. For orders over 100 pcs we can produce the trolley in a different colour chosen by the Customer from the RAL or Pantone palette. Thanks to the stylish design and the possibility of individual adjustment of trolleys to the character of the store, Customer gets not only a functional trolley, but the trolley that furnishes and adorns the interior.

2. Features of Rabtrolley® MINI 80 L

Choosing the right shopping trolley/basket may significantly affect on the store's turnover. Uncomfortable, unsightly, incapacious and uncomfortable to maneuver trolley can effectively discourage the Customer from shopping in the market. Our Rabtrolley® MINI 80 l. guarantees your Clients satisfaction and comfort of use. Its main assets are esthetics of performance, easiness of maintenance, high load capacity, comfort to maneuver, eco-friendliness and security.

2.1 Esthetics of performance ↔ brainy project + plastics

The esthetics of performance and stylish design are undeniable advantages of Rabtrolley® MINI 80l. By using a proper plastics material the trolley gains the lightness that makes it practical and convenient to operate. A wide range of colours allows the maximum customization of trolleys offering your Customers not only a tool to facilitate shopping but also pleasing decoration of the store's interior.

2.2 Increased load capacity ↔ large capacity basket + shelf for bottles

The Rabtrolley® MINI 80l. is a perfect solution especially for markets with small sales area. It is characterized by a smart compact shape with a relatively large load capacity basket (80 l. up to 40 kg.). In many malls the shelvings with beverages are situated near the exit, that makes difficult loading beverages packs for Customers which have already filled their shopping trolleys with chosen goods and they have not enough space to put bottles inside. In such situation the Client may hold back from purchasing beverages, reducing the turnover of the store as well. In turn, placing heavy bottles on the products may unnecessarily crush and destroy already packed articles. Our external shelf for bottles let the Customers put beverages outside the basket in a safe place, isolated from the other products in an easy and comfortable way. We guarantee the load capacity of the bottle shelf for maximally 15 kg, so more than a standard pack of 1,5 liter beverages can weigh.



2.3 Easiness to maneuver ↔ high-quality wheels

Good quality wheels = easy manoeuvring = Customer's comfort

Very often even a relatively good quality shopping trolley may be inconvenient for the Customer because of the difficult maneuvering due to improper installation of wheels. Castors used by us meet the highest quality requirements and they are characterized by high resistance to abrasion and negative effects of the passage of time, causing that the trolley runs smoothly over the commercial surfaces, ensuring the Customer comfort as well. The effect is our Rabtrolley – a shopping trolley easily and smoothly manoeuvrable on commercial surfaces.



2.4 Eco-friendliness ↔ ecological product

Nowadays, the society pays more attention to environmental concerns. Despite appearances, plastics used to produce the shopping trolleys Rabtrolley® are eco-friendly due to the fact that they may be subjected to a re-processing. Our trolleys can be realized in 75% of recycled plastic (versions Eko and Bio). While worn or damaged trolleys are also suitable for re-processing and so they can be reuse in the production of new trolleys!



2.5 Security guarantee ↔ conformity to standards

We have paid much attention to guarantee the security of our products. The design of our trolleys has been created by application of details friendly and secure for the Customer, that eliminates the risk of damages during his shopping time.

The shopping trolleys Rabtrolley® have been designed and manufactured in conformity of standards UNI EN 1929, that define the EU requirements and tests for basket trolleys (with or without a child carrying facility, adapted or not adapted to be used on passenger conveyors) serving the Customers of self-service stores to carry purchased goods.

2.6 Traceability ↔ barcode label + compatibility with RFID technology

Each Rabtrolley® is equipped with a barcode label placed on the frame inside the trolley on the left. The label contains information, written down at the end of the production, that includes the kind of material, year and month of production etc. On the sticker there is also the serial number which allows more accurate verification of all materials used in production.



The Rabtrolley® trolleys are adapted to equip them with a RFID label.

Due to the fact that Rabtrolley® MINI 80 L. trolleys are entirely made of plastics, they are compatible with the innovative RFID technology, which allows to scan and identify all the products at the checkout without the necessity of putting them out on conveyor belts.

3. Versions of Rabtrolley® MINI 80 L.

In our offer we have 6 versions of the model 80L., each of them has been created just to satisfy the special requirements of our Customers.

3.1 MINI 80L Basic – made of 100% polypropylene - material highly resistant to wear and abrasion. This version is available in 5 standard colors: red, orange, light green, blue and black. On Customer's request, for orders over 100 pcs., it is possible to choose any colour from RAL or PANTONE palette, so you can get a personalized shopping trolley, matching the shop 's character, style and equipment.



3.2 MINI 80L Basic Ex – made of 100% polyamide, designed for outdoor storage outside commercial buildings (in trolley shelters). Thanks to addition to polyamide of a special component with high resistance to UV rays, the trolley keeps its colour even in sunlit places. Also this version is available in 5 standard colors: red, orange, light green, blue and black. On Customer's request, for orders over 100 pcs., it is possible to choose any colour from RAL or PANTONE palette.



3.3 MINI 80L Bio – made of 75% recycled plastics and 25% new polypropylene, realised in one colour - wooden like brown - called "wood effect" as well. We recommend this version for ecological food shops. The Rabtrolley® MINI 80 L Bio is also a perfect complement for the interiors of wine-shops and stores with a rustic or "natural" décor.



3.4 MINI 80L Eko – made of 75% recycled plastics and 25% new polypropylene, realised in one colour - black. The Eko is the most economical version of the Rabtrolley® MINI 80L. This variant is a perfect solution for Customers who attach great importance to care for the environment and appreciate excellent quality at an affordable price.



3.5 MINI 80L Glamour – made in 100% of polycarbonate. The stylish shopping trolley will satisfy even the most demanding Customer. The use of plastics containing glassfiber gives to the Rabtrolley® Glamour the transparency effect, keeping all the benefits of the standard version of MINI 80 L as well and gaining even greater resistance to bending and impact. The Glamour is a perfect complement to the shops that "sets much store" by elegance of interiors.



3.6 MINI 80L Flock – made of plastics covered with a special suede like material that gives its surface the velvet effect. The Flock is an elegant solution perfect for the clothing stores, shoe stores and various boutiques as well. This trolley is particularly suitable to be used as a display at different points of the store. Perfect to contain loose products or small boxes.



* All versions of the Rabtrolley® MINI 80L can be realised with or without the coin-lock system

USER'S NOTES

III. Informations for users



RABTROLLEY® MINI 80L – CONSTRUCTION AND DIMENSIONS (mm)

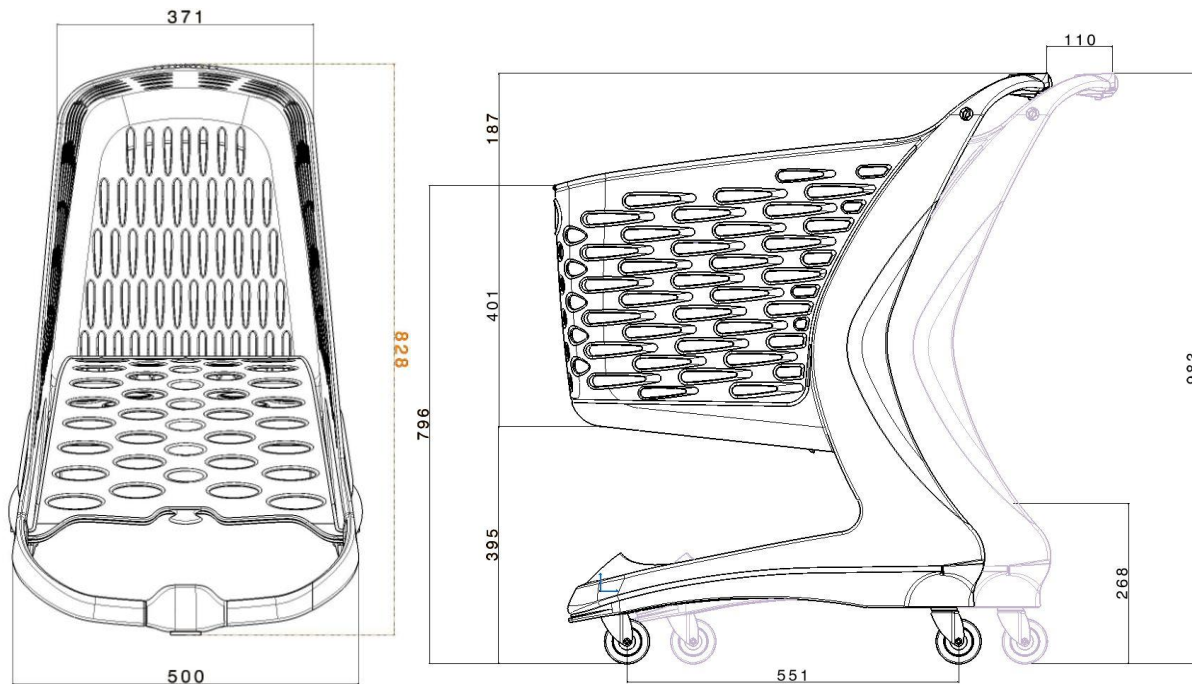

Model Rabtrolley® MINI 80L consists of a basket suspended on a frame (that forms a coherent whole), and separately mounted: plastic flap, shelf for bottles, wheels.

The trolleys Rabtrolley® MINI 80L have been designed and manufactured in conformity of standards UNI EN 1929, that define the EU requirements and tests for basket trolleys (with or without a child carrying facility, adapted or not adapted to be used on passenger conveyors) serving the Customers of self-service stores to carry purchased goods.

The trolleys Rabtrolley® MINI 80L (except the Flock version) are adapted to contact with food. The plastics and accessories we use are nontoxic. The individual components of the trolleys are suitable for reprocessing.

PROPER USE OF TROLLEY AND ITS LOAD CAPACITY

The trolley Rabtrolley® MINI 80L has been designed for the storage and transportation of commercial goods during the shopping in the sales points.

The shopping trolley should be used according to its destination. It is not allowed to use the trolley for other purposes.

The trolley can transport goods with a total weight up to 55 kg, including max. 40 kg. in its basket and max. 15 kg. on its shelf for bottles.

CARRYING CHILDREN

It is **absolutely FORBIDDEN** to carry children inside the Rabtrolley® MINI 80L.

On the handle of the trolley there has been stamped a pictorial instruction of **improper use** of the Rabtrolley® MINI 80L by the youngest Customer:

1. It is forbidden to climb a shelf for bottles and dangle on the back side of the trolley
2. It is forbidden to climb a trolley's frame and dangle on the front side of the trolley
3. It is forbidden to carry children inside the trolley's basket

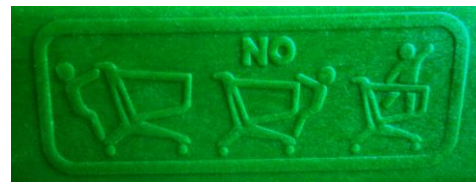

COIN-LOCK SYSTEM

Coin locks are situated on the trolley's handle and they fit to the currency indicated on the coin slot. The use of an inappropriate coin can block the coin slot.

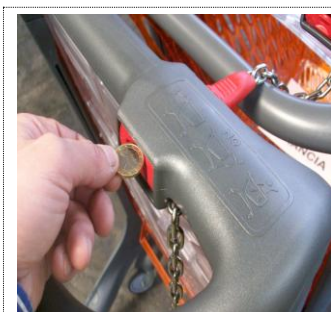

HOW TO GET THE TROLLEY

1. Put a coin into the coin slot of the last trolley.
2. After inserting a coin, the key at the end of the chain connecting the trolleys will be unlocked



HOW TO REPLACE THE TROLLEY

1. Put the last trolley's key into the other side of the coin slot on your trolley's handle
2. After inserting the key, the coin will be automatically ejected from the coin slot.

BAG HANGER AND SHELF FOR BOTTLES (ADDITIONAL SHELF FOR PRODUCTS)

The bag hanger is situated in the trolley's flap.

The shelf for bottles is situated on the back side of the trolley, below the handle and below the basket's level.

The maximal load capacity of the shelf is 15 kg.

The most comfortable way to carry the package of bottles is to put it in horizontal position.



PASSENGERS' CONVEYORS

It is possible to install wheels for passengers' conveyors. Due to the EU regulations Rabtrolley® Mini 80 L on such wheels can be used only outside the European Union.

CLEANING

In order to maintain hygiene we recommend to clean shopping trolleys periodically.

Do not use chemical products for cleaning because they can deteriorate mechanic characteristics of the material.

For cleaning we recommend to use only soap and water at temperature below 60°C.

Thanks to specially designed shape of the perforation of Rabtrolleys® MINI 80L that facilitates the flow of water on the surface of the basket speeding up the cleaning and hindering the deposition of dust on the superficies of the trolley's basket.

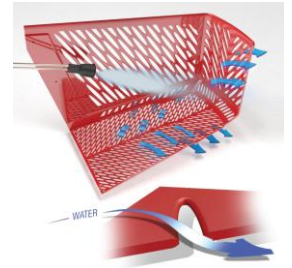

MAINTENANCE AND STORAGE

The Rabtrolleys® basket do not require any specialized maintenance.

To maintain optimal maneuverability the trolley shall be regularly subject to the following operations:

- keep castors clean (remove dirt which is deposited with the axles that could block the wheels).
- control the castors' condition and their proper functioning

In case of any anomalies regarding the castors, please contact our sales office: info@Rabtrolley.com.

The Rabtrolley® shopping trolleys should not be stocked in the areas directly exposed to sunlight. For outdoor storage we recommend to use the adequate trolley's shelters.

GUARANTEE

The Rabtrolley® MINI 80L trolleys are covered by a three-year guarantee on the body of the trolley (items made of plastic: forming a coherent whole basket and frame, flap, as well as optional shelf for bottles).

The trolley's castors and the optional coin-lock system have a two-year manufacturer's guarantee.

The guarantee does not cover damages caused by improper use of the trolley and its components.

TRACEABILITY

Each Rabtrolley® is equipped with a barcode label that contains, in accordance with the EU standards, the following information:

- Name and brand of producer
- Producer's address
- Commercial designation
- Load volume expressed in liters
- Load capacity expressed in kilograms
- Month and year of the production
- Numbers of the UE standards that the trolley is compatible with
- Barcode

Each finished trolley has its individual barcode, that allows to read off the kind of raw material used during its production.

This code is generated automatically by the computer system and printed on the label.



NOTE: In case of complaint it is necessary to indicate the serial number placed on the left side of the label, above the barcode.

FIRE PROTECTION

The Rabtrolley® shopping trolleys should be kept away from sources of fire.

Grades of fire-resistance of Rabtrolley shopping trolleys:

- PA (Poliamide): HB - V2
- PP (Polypropylene): HB – V2
- PC (Polycarbonate): HB - V2



HIGHLY SELF-EXTINGUISHING PRODUCTS IN CONFORMITY OF THE STANDARD UL 94

Analysis made by the American [Underwriters Laboratories](#) are the most popular tests of flammability and self-extinguishing of polymers.

HB

This test consist in the measurement of burning time of a horizontally placed plastic sample, that has a specified thickness (3 mm), by a Bunsen flame for 30 sec.

According to the standard **UL 94 HB** {Horizontal Burning } the material is categorized as HB if the sample of the thickness of 3 mm burns at maximum speed of 76 mm/minute. The materials classified as HB are considered self-extinguishing materials.

V.0 , V.1 , V.2

These tests (**UL 94 V.0 , V.1 , V.2** – {Vertical Burning}) consist in the measurement of self-extinguishing time of a vertically placed plastic sample, that has thicknesses from 3 till 6 mm , burned by a Bunsen flame for 10 sec.

- V.0– the categorization of the material if the flame extinguishes within 10 seconds;
- V.1– the categorization of the material if the flame extinguishes within 30 seconds without dripping;
- V.2– the categorization of the material if the flame extinguishes within 30 seconds with dripping.

PRODUCER:

Rabugino Sp.zo.o.
ul. Graniczna 48, 05-825 Grodzisk Mazowiecki, Polska

www.Rabtrolley.com
info@Rabtrolley.com

DISTRIBUTOR: (space for stamp of the distributor)