



Powered Air Purifying Respirators

**AIR WING**<sup>®</sup>



Please keep this instruction manual for your further reference.

- This product complies with the requirements of European standard EN12941.
- Please refer to the other instruction manual for the use of auto darkening welding helmet.

## TABLE OF CONTENTS

---

Danger/Caution/Notice .....	4
How to Use .....	5
Spare Parts .....	11
PAPR Parts Description .....	12
Trouble Shooting upon Types of Malfunction .....	13~14

# Air Wing

This product with its attached dust filter purifies airborne dust, pollutants, fine particles as well as other contaminants, welding dust, metal dust, and supplies clean air to the user's facial area.

## 1. Usage

This product may be used in workplaces with sufficient amount of oxygen including welding shops (grinding and polishing) where various airborne heavy metal dusts are generated, sanding or grinding workshops, workshops that handle hazardous materials such as asbestos, and any other workshops where airborne dusts are generated.

## 2. Danger

- ① When NOT aware of, what the contaminant generated in workplace is and concentration of the contaminant in the air, or in case of such concentration level (IDLH) that may occur immediate danger for health and/or life, please do NOT use this product.
- ② When the oxygen concentration of the air in workplace is 18% or lower, do NOT use this product.
- ③ Without filter equipped, NEVER use this product. It may cause such danger for human life. (Use those filters that OTOS Co., Ltd. sells.)
- ④ Only those parts and components included in product component table/picture must be used and do NOT use them for other usage rather than this product.
- ⑤ Do NOT use this product in such place totally sealed.
- ⑥ Do NOT use this product in places with such dangers as fire and explosion.
- ⑦ Do not directly connect the filter to safety caps or face guards.

## 3. Caution

- ① Do NOT use at workplace with strong wind. (as negative pressure generated inside the hood, outside-air comes into the hood)
- ② alarming, immediately get away from the contaminated area and check up the device. In any cases below, please get away from that contaminated place.
  - . When some problem is shown in any part of the product;
  - . When the air supply is stopped or its amount is decreased;
  - . When it gets hard to breathe;
  - . When feeling dizzy or headache;
  - . When feeling the smell or taste of the contaminants and its stimulus occurred;
- ③ Do NOT put the battery near fire and/or its heat.

- ④ Do not use the product with its power turned off since carbon dioxide concentration may increase and oxygen level inside the face guard may decrease.
- ⑤ Do not use if the product does not supply enough air. (MIN - 160 ℓ / min)
- ⑥ Do not use the product in work environments where the level of contamination is too high rendering the product to stop functioning and cause serious injury.
- ⑦ The product is designed to be used in the temperature range between -5℃ and +55℃.

## 4. Notice

- ① Please follow the direction described in this manual and be aware enough of how to use and how to wear before using this product. If using this product in wrong direction, it may cause danger.
- ② Before use this product, please check up if the Air Wing's body is connected right with the hood and the connecting hose. (See page 6 ~8)
- ③ Before use this product, please check up airflow with the flow-meter. (MIN -160 ℓ / min -See page 8)
- ④ Before get away from the contaminated area, do NOT take off the hood or do NOT stop operation of the Air Wing.
- ⑤ Do NOT disassemble the product. It may cause malfunction and free of charge A/S (warranty) service is not provided.
- ⑥ Make sure the connecting hosepipe stoops and is not entangled or is in the way of other items in the area.
- ⑦ When verifying the protection grade of the product, make sure the user does not confuse the European standard EN12941 label with those associated with other standards.

## 5. Features

- ① This product has particle filter and Odor Filter. Also, this product has alarming function (sound and display panel) that gives notice when such dangers as low battery or lack airflow.
- ② In order NOT to let the outer air come inside the hood, it generates positive pressure so it blocks harmful objects getting into.
- ③ This product is suitable for prevention of respiratory contagious disease and such workplaces that have bad smell, normal dust, harmful objects, and particulate objects floating in the air.
- ④ It guarantees smoother breath compared to facial mask and it protects worker from harmful factors.
- ⑤ Ultra-light hood and shoulder-strap reduce feeling weight and fatigue when wearing for long time.

## 6. Check-up points before use;

- ① If the filter is equipped right, (See page 5)
- ② If the connecting hose has any problem and is connected to the Air Wing's body exactly, (See page 6~7)
- ③ If right airflow is supplied upon taking airflow test, (See page 8 for airflow test)
- ④ If alarm sounds exactly and danger indication (  ) is displayed right blocking outlet when operating Air Wing.
- ⑤ If the hood has any problem, -check up any part being torn or any part with wrong needlework
- ⑥ If the air is supplied into the facial part when operating Air Wing.

## 7. Filter

- ① Particle filter : purifies fine particles and mote contaminant.
- ② Odor Filter : After the particle filter process, the odor filter removes foul odor and odor particles.



Unsealed filter is valid for 5 years since the manufactured date.

## 8. How to equip the Particle Filter

- ① The power must be turned off when replacing the filters.
- ② Assemble the wire netting and pre-filter to the filter cover in order and then assemble the particle filter as shown in the 'Picture 1'
- ③ Place the filter cover on the main body of the Air Wing and lock it by turning it clockwise until it clicks.

Picture 1' – Assembling particle filter

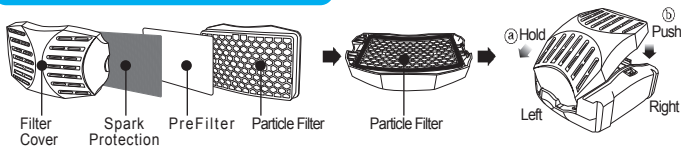

## 9. How to equip the Odor Filter

- ① As shown in the 'Picture 2', mount the Odor Filter to the left of the Air Wing's body first, and then push the right until hearing "Click" sound.
- ② Mount the filter cover on the left of the Odor Filter first, and then push the right until hearing "Click" sound.





Do NOT use Odor Filter without Particle filter

Picture 2' – Assembling the Odor Filter

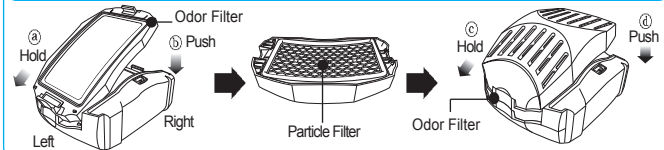
(Please equip the Particle Filter after equipping the Odor Filter first.)



## 10. How to operate

- ① How to start : Press 'ON' button on the body for 1~2 seconds then the product gets started operating with warning alarm.(Picture 1)
- ② Airflow Control : If the product is operated first, it starts with LOW  (160  $\ell$  / min) at the flow-meter. When more airflow is needed, press 'FLOW' button once again and set the airflow at HIGH  (200  $\ell$  / min). If 'ON' button is pressed once again at HIGH, it becomes LOW again. (Picture 2)
- ③ How to stop : Press 'OFF' button for 2~3 seconds then the product gets stopped operating with warning alarm. (Picture 3)

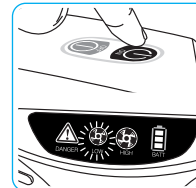

Picture 1. How to Start

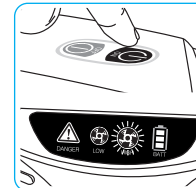

Picture 2. Airflow Control

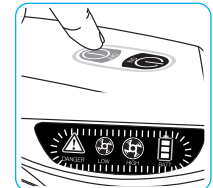

Picture 3. How to Stop

# Air Wing

## 11. Assembling/Disassembling the Battery

- ① How to assemble the battery : Fitting the battery to the Air Wing's body, push until hearing "Click" sound.

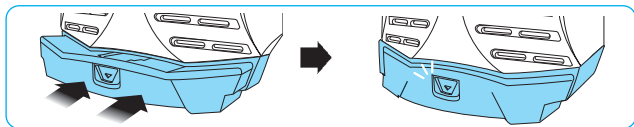

- ② How to change the battery:

- while pushing down the button to separate the battery,
- pull the battery and separate it from the body.



## 12. Battery-charging

- When using the battery for the first time or reusing after not using for over 5 days, the battery must be charged again for use.
- If the battery has not been used for 3 months or more, it needs to be fully charged twice for maximum charging capacity.
- The battery should be charged in a place that is electrically safe.
- Please separate the battery from the body before charging.
- Full-charging takes about 4 hours. Charging time depends on the remaining battery capacity.
- Please check out the voltage of the charger (220V).
- Upon using-condition, the battery's life may be slightly different.
- When the battery is fully charged, the Red light turns Green light.

### ■ How to charge the battery:

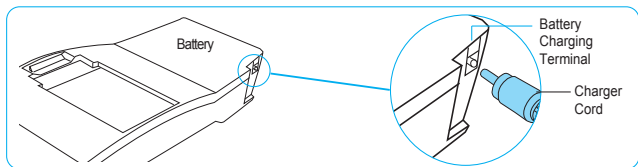

## 13. Caution for battery use

- Do not put PAPR unit with power-on in the bag.
- Do not keep PAPR unit inside the car in hot summer season.
- Do not throw or give the high impact to PAPR unit.
- Do not keep PAPR unit with metallic things.
- Do not put PAPR unit on the electric heat generating equipment.
- Do not use any other battery charger.
- When the fluid leakage from the battery or smell is detected, contact customer service center immediately.

▶ Battery operation time: 8 hours (+/-5%) at nominal flow (160 l/min).

## 14. Battery-charger

- Pay attention to the following exposition to reduce the dangers of fire and electric shock.
- For power supply connection, use adequate plug adaptor for the electric outlet.
- When fully charged, remove from the main power source.
- Suggested temperature during charging is between 0°C and 40°C.
- When being charged, red light is turned on signaling the charging is in process. When fully charged, green light is turned on.
- Do NOT use the charger for any other usage than charging this product's battery charging.
- The charger has been made only for indoor use and it should be stored in a place without humidity.
- The charger type:
  - Model Name: AW-100-11
  - Input Voltage: AC 220V
  - Output Voltage: (when charged with standard capacity) DC 16.8V 800mA

## 15. Assembling the connecting hose

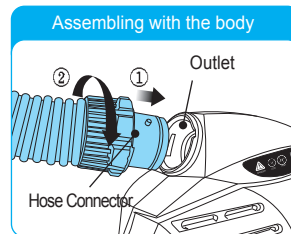

- Assembling with the body : Properly stick the hose connector into the ① outlet. After that, as shown in the above picture, turn the ② connector halfway round to the right and then mount to the body.

## Assembling with the hood Hose

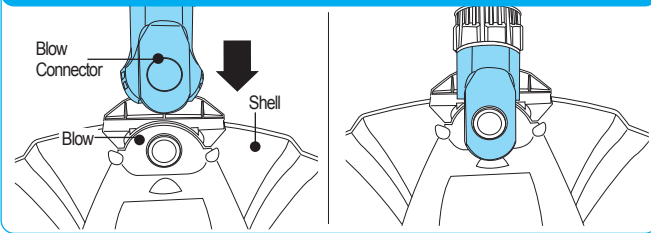

- Assembling with the hood Hose :  
Connect the blow connector of the hose to the blow of the hood. At this time, check out if the blow connector and the blow are exactly connected. If they are not exactly assembled, outer air may get inside and also air of suitable airflow may not be supplied.

## 16. Air flow control

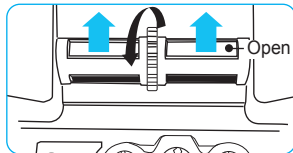

Picture 1.

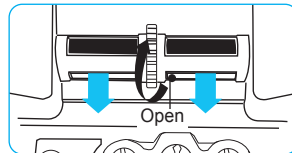

Picture 2.

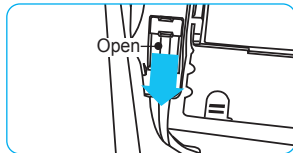

Picture 3.

- ① Picture 1 - When you want to send the airflow to the forehead.
- ② Picture 2 - When you want to send the airflow to the face.
- ③ Picture 3 - When you want to send the airflow to the mouth.

## 17. How to shorten the length of the hose

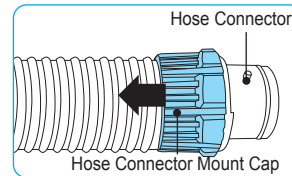

Picture 1.

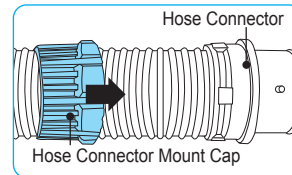

Picture 3.

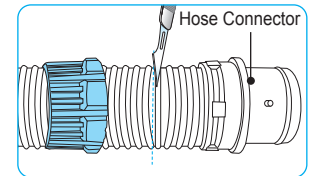

Picture 2.

- ① Fix the length of the hosepipe fitting to the user's environment.
- ② Pull the hose connector mount cap and separate it from the hose connector. (Picture 1)
- ③ Cut the hose upon intended length. (Picture 2) And then, the hose connector, put it into the hose. (Picture 3)

## 18. Assembling the shoulder strap

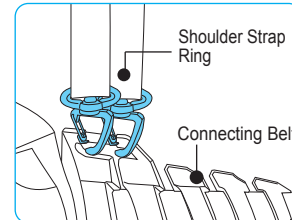

Picture 1.

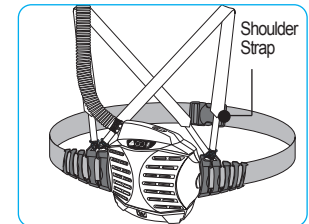

Picture 2.

- Assembling the shoulder strap :  
Hook up the shoulder strap ring with left / right connecting belt to mount the rear / front shoulder strap.

# Air Wing

## 19. Assembling the Belt Cushion

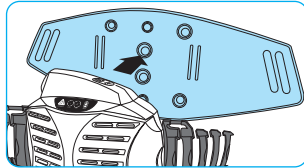

Picture -1. Interlocking with the Air Wing

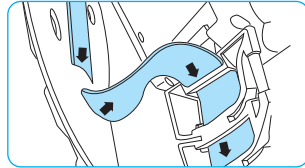

Picture -2

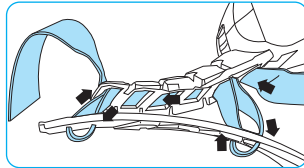

Picture 3. Assembling the Belt Cushion

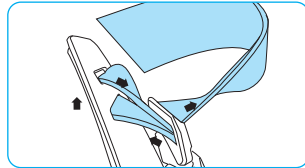

Picture 4.

- ① Like the picture, insert the belt in the belt cushion hook and insert the belt to the belt connector.(picture)
- ② After inserting the belt into the belt connector, put the belt again into the belt cushion, and then again put the belt into the belt connector. Do the same way for the other side.(Picture 4)

## 20. Assembling the connecting hood

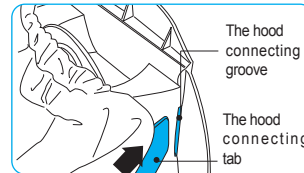

Picture 1.

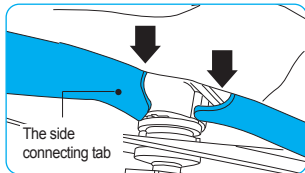

Picture 2.

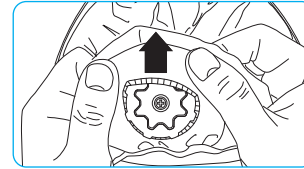

Picture 3.

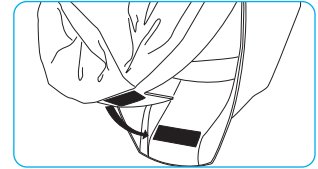

Picture 4.

- ① On the upper part of the blower, put the hood connecting tab into the hood connecting groove.(Picture 1)
- ② After connecting the upper part of the hood, push the side connecting tab of the hood to the headgear till you hear "Tick" sound. (Picture 2)
- ③ Put the headgear adjusting knob into the hood hole. (picture 3)
- ④ After connecting the upper part and side part of the hood, attach the Velcro of the bottom part of the hood to the helmet shell. (Picture 4)

## 21. Airflow Test

- ① Take airflow test always before using this product.
- ② Make sure the dust filter is mounted and its battery fully charged.
- ③ Put the Flow Indicator into the blow mount cap of the hose. (Picture 1.)
- ④ While taking airflow test, be careful for the hose not to be twisted.
- ⑤ While taking airflow test, keep the Flow Indicator (airflow tester) vertical way.
- ⑥ Before taking airflow test, check out if airflow display indicates LOW (LOW) and then perform test. (Picture 2.)-When airflow indication is at LOW (LOW), airflow is 160  $\ell$ /min.
- ⑦ While taking airflow test, check up if it indicates MIN as well. (Picture 3.)
- ⑧ If the gauge on the Flow Indicator is low, inspect according to the 'When the gauge on the Flow Indicator is low' item from 'Troubleshooting' on page 13.

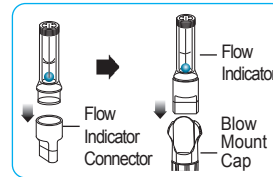

Picture 1.

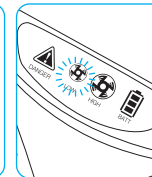

Picture 2.

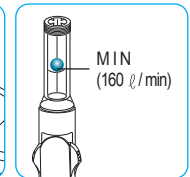

Picture 3.

## 22. Alarm sound check-up

After turning on the product, check the malfunction warning function by blocking the air outlet as shown in the picture below. The warning signal on the panel should flash with a sound after the outlet is blocked. If the alarm light is on, and vibration and alarm sound work properly, the product is working correctly.

(Please check out if dust-removing filter is equipped and the battery is fully charged.)

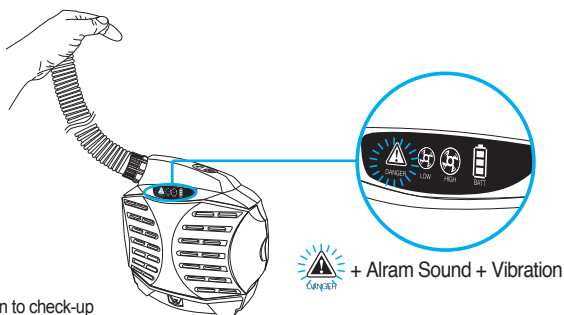

### ■ When to check-up

Section	Time to check-up
Airflow Check-up	Always before use
Regular Check-up	Once a month if not using regularly

## 23. Technical Data

① EN 12941 (standard for breathing protection motor assisted filter protection with helmet or hood)

② TH2 P (SL) (classification of the unit with regards to protection when using particulate filters.

The number '2' defines the level of protection (inward leakage) within the classification, whilst the letter 'P' indicates use of a particulate filter and letters 'SL' show that the filter has been tested against particles of liquid or solid matter in gas

## 24. Washing

- ① Dissolve home detergent lightly in the water and use a clean cloth for washing. (When washing, be careful for the water not to get inside the body.)
- ② Do NOT use petroleum, organic solvent, grinding detergent, and so on.



- Do NOT wash or reuse the filters used once.
- When washing, be careful for the water NOT to get inside the body.

## 25. Maintenance

The air hose must be checked regularly and must be changed if it is damaged and causes leakage. Faulty connections must be rectified. The particle filter must be changed if the battery operating time becomes too short or it is blocked and does not give enough air flow. The particle filter CANNOT be cleaned. Do not attempt to remove contamination using a compressed air line as this will automatically invalidate the warranty. The battery must be charged, as noted in the instructions, when the low battery alarm sounds. The face seal must be changed if it is damaged, dirty or uncomfortable.

## 26. Specifications

- Manufacturer's minimum design flow rate : 160 ℓ / min
- Nominal Air flow : ~160 ℓ / min
- Airflow Plus : 200 ℓ / min
- Headband size : 68.5cm
- Comfort belt size : 70~113cm
- Operation temperature : -5℃ ~ + 55℃
- Weight, welding helmet incl. air hose : 980g
- Weight, PAPR Unit (incl. filter) : 1350g
- Battery life : App. 500 charges



## 27. Warranty(Caution of using)

OTOS.Co.,Ltd Warrants all PAPR for 12 months from the date of purchase.

OTOS.Co.,Ltd is obliged to repair material and fabrication defects free of charge within the warranty period.

This warranty does not cover to cause by improper handling abuse or application other than recommended in the user instruction.

Practical use of Warranty: If you would like to place a claim for warranty period, send the defective parts together with the completed defect report and the warranty card to your distributor.

## 28. Symbols



: Read instruction before use



: Expiry date year / month











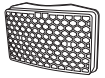

0299 : Identification code for approved test authority

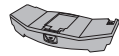

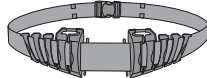
■ Product Component

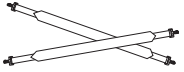
Hood (choose one of Hood Type-A, Hood for Welding, and Face-Protection Hood), Powered respiratory protection device, Particle filter, Prefilter, Spark protection, Belt set (shoulder-strap included), Belt cushion, Flow indicator, Battery, Battery-Charger, and User Manual.

\* Please check out each component and if there is any component missing or some damage shown, contact with A/S center.

Category	Category Name	Part No.	Qty.	Category	Category Name	Part No.	Qty.	Category	Category Name	Part No.	Qty.
	Air Wing Body	AW - 100 - 1	1EA		Particle Filter (Pa)	AW - 100 - 3S	2EA		PreFilter	AW - 100 - 4	1EA
	Spark Protection	AW - 100 - 5	1EA		Filter Cover	AW - 100 - 6	1EA		Battery	AW - 100 - 7	1EA
	Battery Charger	AW - 100 - 11	1EA		Belt Set	AW - 100 - 8	1EA		Belt Cushion	AW - 100 - 14	1EA
	Shoulder Strap	AW - 100 - 9	1EA		Air Hose	AW - 100 - 10B	1EA		Flow Indicator	AW - 100 - 12	1EA

\* Option

Category	Category Name	Part No.	Qty.	Category	Category Name	Part No.	Qty.	Category	Category Name	Part No.	Qty.
	Helmet Shell Ace-W with Face seal	AW - ACE - W	1EA		Odor Filter	AW - 100 - 2	Filter 2EA/ Filter Case 1EA		Air Hose Cover	AW - 100 - 10C	1EA

# Air Wng

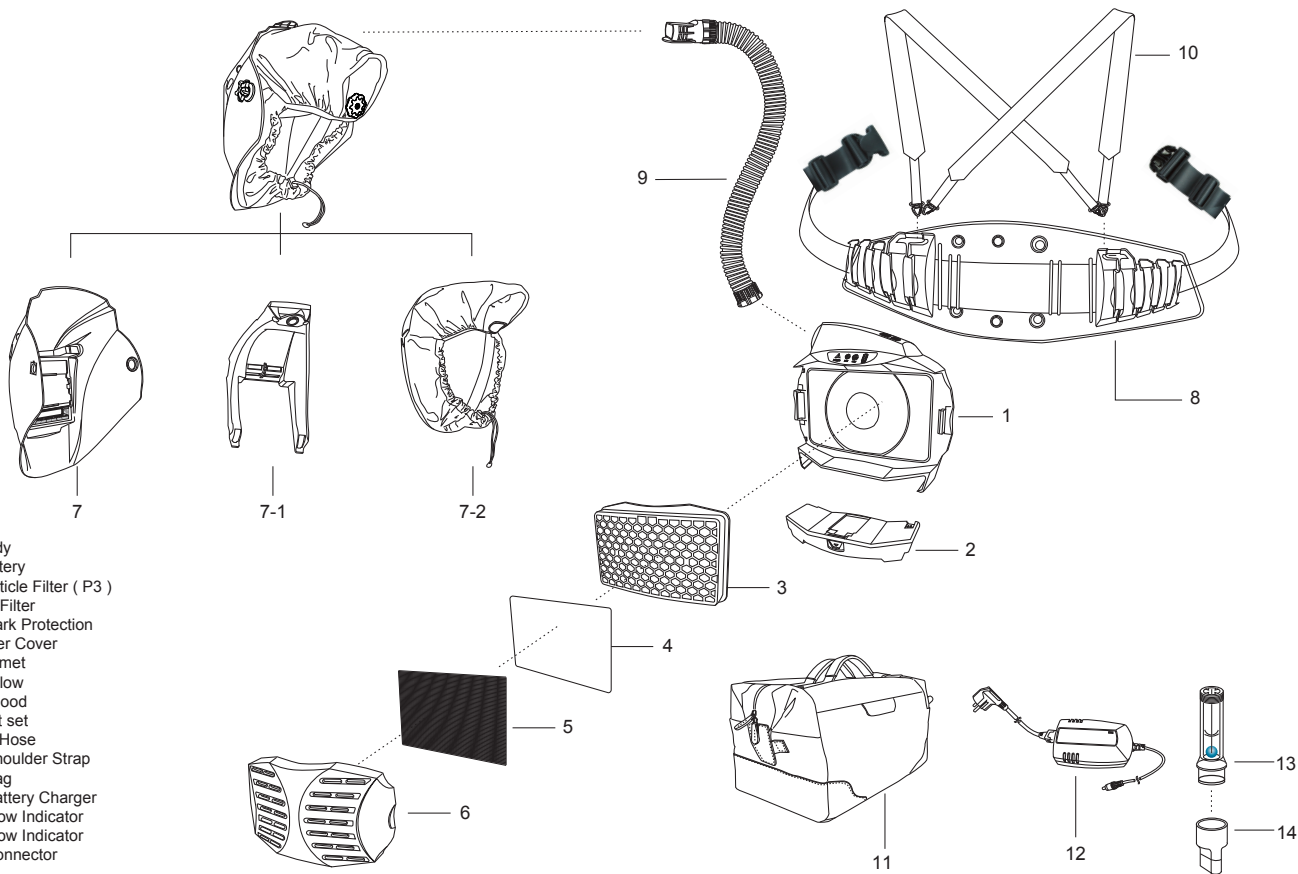

- 1 - Body
- 2 - Battery
- 3 - Particle Filter ( P3 )
- 4 - PreFilter
- 5 - Spark Protection
- 6 - Filter Cover
- 7 - Helmet
- 7-1 - Blow
- 7-2 - Hood
- 8 - Belt set
- 9 - Air Hose
- 10 - Shoulder Strap
- 11 - Bag
- 12 - Battery Charger
- 13 - Flow Indicator
- 14 - Flow Indicator Connector

1. Please check up following trouble shooting types when it is not operated or operation is not smooth.

2. If problem is not solved even after checking up upon each type of trouble shooting, please apply for A/S service at head office.

Troubles	Causes	Trouble-Shooting
<ul style="list-style-type: none"> <li>When the body of Air Wing does NOT supply the air into the hood (face area)</li> </ul>	<ul style="list-style-type: none"> <li>The Air Wing is not being operated.</li> </ul>	<ul style="list-style-type: none"> <li>Press 'ON' button for 1~2 seconds. Then, the Air Wing gets operated with alarm sound.</li> </ul>
	<ul style="list-style-type: none"> <li>The battery connection and charging status are NOT right.</li> </ul>	<ul style="list-style-type: none"> <li>Check up if the battery is charged or is assembled well with the body. (Upon use-conditions, battery's life differs as well.)</li> </ul>
	<ul style="list-style-type: none"> <li>The hose and the outlet are blocked because of some other objects.</li> </ul>	<ul style="list-style-type: none"> <li>Please check out the outlet and the (connecting) hose.</li> </ul>
<ul style="list-style-type: none"> <li>When operation of the Air Wing body does NOT stop</li> </ul>	<ul style="list-style-type: none"> <li>The power of the Air Wing body is not off.</li> </ul>	<ul style="list-style-type: none"> <li>Press 'OFF' button for 2~3 seconds. Then, the Air Wing gets stopped with alarm sound.</li> </ul>
<ul style="list-style-type: none"> <li>When using time is too short even though the battery is fully charged</li> </ul>	<ul style="list-style-type: none"> <li>The battery life has been all gone.</li> </ul>	<ul style="list-style-type: none"> <li>The battery is not usable permanently. Please change the battery for new one. (Its life may differ upon using conditions.)</li> </ul>
	<ul style="list-style-type: none"> <li>The charger is NOT in good condition.</li> </ul>	<ul style="list-style-type: none"> <li>Change the charger or contact A/S center at head office.</li> </ul>
<ul style="list-style-type: none"> <li>When the gauge on the flow-meter is low</li> </ul>	<ul style="list-style-type: none"> <li>The connecting hosepipe and outlet is clogged by foreign substances.</li> </ul>	<ul style="list-style-type: none"> <li>Check the connecting hosepipe and outlet and remove any foreign substances.</li> </ul>
	<ul style="list-style-type: none"> <li>The particle filter is covered with foreign substances.</li> </ul>	<ul style="list-style-type: none"> <li>Check the air outlet on the filter cap and remove any foreign substances.</li> </ul>
	<ul style="list-style-type: none"> <li>The particle filter is clogged.</li> </ul>	<ul style="list-style-type: none"> <li>Replace the dust filter.</li> </ul>

# Air Wing

Troubles	Causes	Trouble-Shooting
<ul style="list-style-type: none"> <li>When the warning light is 'ON' at the battery indication panel and Vibration, alarm sound is beeping</li> </ul>	<ul style="list-style-type: none"> <li>The power of battery starts to run out.</li> </ul>	<ul style="list-style-type: none"> <li>After the battery warning light is 'ON', it is possible to still use for about 15 minutes but please get away from the contaminated area and replace the battery or charge the battery again since it depends on the conditions of use.</li> </ul>
<ul style="list-style-type: none"> <li>When the warning light is 'ON' at danger indication panel and Vibration, alarm sound is beeping</li> </ul>	<ul style="list-style-type: none"> <li>The inlet, outlet, or hose are blocked.</li> </ul>	<ul style="list-style-type: none"> <li>Please check out if the inlet/outlet/hose is blocked before use. If alarm is continuously beeping, please contact the agent (dealer) or A/S Dept. of head office.</li> </ul>
	<ul style="list-style-type: none"> <li>The vinyl for packaging filter is still remained.</li> </ul>	<ul style="list-style-type: none"> <li>The filter is sold in a vacuum package so that it does not be contaminated from the outer air. When equipping the filter to the body, please remove the packaging vinyl.</li> </ul>
<ul style="list-style-type: none"> <li>When feeling smell and taste of the incoming air</li> </ul>	<ul style="list-style-type: none"> <li>The Odor Filter is seriously contaminated.</li> </ul>	<ul style="list-style-type: none"> <li>Please check out the level of contamination of the Odor Filter and replace with the new filter.</li> </ul>
	<ul style="list-style-type: none"> <li>Assembling the filter and the hose are not well or the hose has some problem.</li> </ul>	<ul style="list-style-type: none"> <li>Please check out how the filter and the hose are assembled and check up the (connecting) hose.</li> </ul>
	<ul style="list-style-type: none"> <li>Only particle filter is used.</li> </ul>	<ul style="list-style-type: none"> <li>Please equip and use both of the particle filter and the Odor filter.</li> </ul>
<ul style="list-style-type: none"> <li>When the amount of incoming air reduced</li> </ul>	<ul style="list-style-type: none"> <li>Assembling the hose and the outlet is not well or the hose has some problem.</li> </ul>	<ul style="list-style-type: none"> <li>Please check out if the outlet and the hose are assembled well and check out if the (connecting) hose is blocked or has some problem.</li> </ul>



Powered Air Purifying Respirators  
**AIR WING®**

**OTOS CO., LTD.** 234-12, Gasan-Dong, Kumchun-Gu, Seoul, Korea  
224-16, Seogeun-Ri, Paltan-Myun, Hwasnug-City, Kyunggi-Do, Korea