

FireStingO₂

FIBER-OPTIC OXYGEN METER

USER MANUAL



Document Version 3.07

Refers to *Pyro Oxygen Logger Software* version >3.1

The *FireStingO2* is manufactured by

PyroScience GmbH

Hubertusstr. 35

52064 Aachen

Germany

Phone +49 (0)241 4004 555

Fax +49 (0)241 4004 558

Email info@pyro-science.com

Internet www.pyro-science.com

Registered: Aachen HRB 17329, Germany

TABLE OF CONTENT

1	OVERVIEW	6
2	SAFETY GUIDELINES	8
3	INTRODUCTION TO THE <i>FIRESTINGO</i>₂	11
4	SOFTWARE INSTALLATION	13
5	OXYGEN SENSOR TYPES	14
5.1	NEEDLE-TYPE SENSORS.....	14
5.2	BARE FIBER SENSORS	17
5.3	ROBUST PROBES.....	19
5.4	SENSOR SPOTS.....	20
5.5	FLOW-THROUGH CELLS	22
5.6	RESPIRATION VIALS.....	23
5.7	CONNECTING THE SENSORS.....	24
5.8	CLEANING AND MAINTENANCE OF THE SENSORS.....	25
6	THE SOFTWARE “PYRO OXYGEN LOGGER”	27
6.1	MAIN WINDOW.....	27
6.2	SETTINGS.....	35
6.2.1	<i>Basic Settings</i>	37
6.2.2	<i>Advanced Settings</i>	38
6.2.3	<i>Conditions in the Sample</i>	39
6.2.4	<i>Temperature</i>	41
6.2.5	<i>Options</i>	43
6.3	OVERVIEW PANEL	45
6.4	RAW DATA WINDOW	46
7	CALIBRATION WITH “PYRO OXYGEN LOGGER”	48
7.1	CALIBRATION PROCEDURE.....	49
7.1.1	<i>Calibration Mode: Factory</i>	51
7.1.2	<i>Calibration Mode: 1-Point in Ambient Air</i>	52
7.1.3	<i>Calibration Mode: 1-Point in Water or Humid Air</i>	54
7.1.4	<i>Calibration Mode: 2-Point in Ambient Air</i>	56
7.1.5	<i>Calibration Mode: 2-Point in Water or Humid Air</i>	58

7.1.6	<i>Calibration Mode: Custom Mode</i>	61
7.2	CALIBRATION WITH A 1.GENERATION <i>FIRESTINGO</i> ₂	65
7.2.1	<i>Calibration Mode: Factory (1. Generation FireSting)</i>	66
7.2.2	<i>Calibration Mode: 1-Point (1. Generation FireSting)</i>	66
7.2.3	<i>Calibration Mode: 2-Point (1. Generation FireSting)</i>	69
7.2.4	<i>Calibration Mode: Custom (1. Generation FireSting)</i>	71
7.3	ADVANCED ADJUSTMENTS.....	72
8	CALIBRATION STANDARDS	74
8.1	THE AIR CALIBRATION STANDARD	74
8.1.1	<i>Ambient Air</i>	76
8.1.2	<i>Water-Vapor Saturated Air</i>	77
8.1.3	<i>Air Saturated Water</i>	77
8.2	THE 0% STANDARD.....	78
8.2.1	<i>Water Mixed with a Strong Reductant</i>	78
8.2.2	<i>Water Flushed with Nitrogen Gas</i>	79
8.2.3	<i>Nitrogen Gas</i>	79
9	CALIBRATION OF CONTACTLESS SENSORS	80
9.1	CALIBRATION PROCEDURE.....	80
9.2	MANUAL BACKGROUND COMPENSATION	81
10	TEMPERATURE MEASUREMENT	83
10.1	AVAILABLE EXTERNAL TEMPERATURE SENSORS.....	83
10.2	INTERNAL TEMPERATURE SENSOR	83
10.3	AUTOMATIC TEMPERATURE COMPENSATION.....	84
11	ANALOG OUTPUT AND AUTO-MODE	86
11.1	ANALOG OUTPUT	86
11.2	AUTO-MODE.....	89
11.3	ADVANCED AUTO-MODE	91
12	APPENDIX	93
12.1	SPECIFICATIONS OF THE <i>FIRESTINGO</i> ₂	93
12.2	EXTENSION PORT X ₁	95
12.2.1	<i>Connector X₁ (Power, Digital Interface, Analog In)</i>	95
12.2.2	<i>Connector X₂ (Analog Output)</i>	100
12.3	TROUBLESHOOTING	101

12.4	MEASURING PRINCIPLE	102
12.5	OPERATING SEVERAL <i>FIRESTINGO</i> ₂ IN PARALLEL.....	104
12.6	DEFINITION OF OXYGEN UNITS.....	105
12.7	TABLE OF OXYGEN SOLUBILITY	107
12.8	EXPLANATION OF THE SENSOR CODE	109

1 Overview

The compact USB-powered fiber-optic oxygen meter *FireStingO2* with 1, 2, or 4 channels unifies several innovative technological improvements making it the new standard of high precision oxygen sensing with fiber-optical oxygen sensors (optodes). The *FireStingO2* utilizes a measuring principle based on red light excitation and lifetime detection in the near infrared using unique luminescent oxygen indicators (*REDFLASH technology*, see Appendix 12.4 for more details). It is a multipurpose oxygen meter

- enabling measurements in water as well as in gas phases,
- working with fiber-based sensors comprising several size classes like microsensors, minisensors, or robust probes,
- working with contactless sensors like sensor spots, flow-through cells or respiration vials, and
- working with full range and trace oxygen sensors.

The *FireStingO2* has integrated atmospheric pressure and humidity sensors for a precise and easy sensor calibration, but also for automatic pressure compensation of the oxygen measurements. Furthermore, the *FireStingO2* offers 4 analog outputs and a built-in temperature port for an external temperature sensor allowing automatic temperature compensation of the oxygen measurement. If independent temperature compensation for all oxygen channels is needed, a USB-powered temperature extension module *TeX4* can be easily fixed below the *FireStingO2* meter with a smart docking mechanism. The user-friendly *Pyro Oxygen Logger* software allows operation of several *FireStingO2* meters in parallel as a multi-channel system.

Along with the *FireStingO2* we offer turnkey motorized microprofiling setups for measurements of depth-profiles of oxygen concentration in semi-solid environmental samples and

along micro-gradients at high temporal and spatial resolution, as well as customized OEM solutions.

More information concerning our products can be found at www.pyro-science.com

or contact us under info@pyro-science.com.

We would be pleased to serve you concerning all needs for high precision oxygen sensing.

Your *PyroScience* Team

2 Safety Guidelines

The *FireStingO₂* is a laboratory instrument to be used with fiber-optic oxygen sensors (optodes) from *PyroScience* for measuring oxygen at high precision and resolution. In order to guarantee an optimal performance of the *FireStingO₂* please follow these operation instructions and safety guidelines.

If any problems or damage evolve, please disconnect the instrument immediately, mark it to prevent any further use and consult *PyroScience* for repair or maintenance service. The *FireStingO₂* should not be manipulated or opened by unauthorized persons, only by *PyroScience* or persons advised directly from *PyroScience*.

Please note that opening the housing will void the warranty. There are no serviceable parts inside the device.

The *FireStingO₂* and sensors should be kept and stored outside the reach of children in a secure place under dry and clean conditions at room temperature, avoiding moisture, dust, corrosive conditions and heating of the instrument. This device and the sensors are not intended for medical, military or other safety relevant areas. They must not be used for applications in humans; not for in vivo examination on humans, not for human-diagnostic or therapeutic purposes. The sensors should not be brought in direct contact with foods intended for consumption by humans.

The *FireStingO₂* should be used in the laboratory by qualified personal only, following the operation instructions and safety guidelines of this manual. Please follow the appropriate laws and guidelines for safety like EEC directives for protective labor legislation, national protective labor legislation, safety regulations for accident prevention and safety data-sheets from manufacturer of chemicals used during measurements.

Calibration and application of the sensors, data acquisition, data processing and data publication is on the user's authority.

When used in the field, the environmental conditions (like high humidity, dust, exposure to direct solar radiation) may cause damage or interference of the *FireStingO₂*, which is on the user's authority.

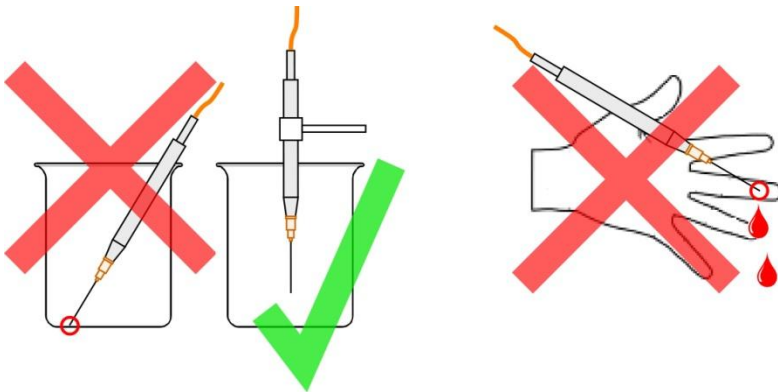

Before using the *FireStingO2* and its sensors, read carefully the instructions and user manual for the oxygen meter *FireStingO2*.

In case of problems or damage, disconnect the instrument and mark it to prevent any further use! Consult *PyroScience* for advice! There are no serviceable parts inside the device. Please note that opening the housing will void the warranty!

The *FireStingO2* is not watertight, is sensitive to corrosive conditions and to changes in temperature causing condensation. Avoid any condition (e.g. direct sun light) causing a heating of the device above 50°C (122°F) or below 0°C. Avoid any elevated humidity causing condensing conditions.

Handle the sensors with care especially after removal of the protective cap! Prevent mechanical stress to the fragile sensing tip! Avoid strong bending of the fiber cable! Prevent injuries with needle-type sensors!

Calibration and application of the sensors is on the user's authority, as well as data acquisition, treatment and publication!

The sensors and the oxygen meter *FireStingO2* are not intended for medical, diagnostic, therapeutic, or military purposes or any other safety-critical applications. The sensors must not be used for applications in humans and should not be brought in direct contact with foods intended for consumption by humans.

The *FireStingO2* and sensors should be used in the laboratory only by qualified personal following the user instructions and the safety guidelines of the manual, as well as the appropriate laws and guidelines for safety in the laboratory!

Keep the sensors and the oxygen meter *FireStingO2* outside the reach of children!

3 Introduction to the *FireStingO2*

The *FireStingO2* is an optical oxygen meter that is compatible with a broad range of oxygen sensors from *PyroScience*:

- microsensors and minisensors (retractable needle-type, fixed needle-type, or bare fiber),
- robust probes and
- contactless sensors (sensor spots, respiration vials, flow-through cells)

Most sensors are available in versions for the full range (0-100% O₂) and for the trace range (0-21% O₂). The optical detection technology is based on the unique oxygen-sensitive *REDFLASH indicators* which use red light excitation and lifetime detection in the near infrared (see Appendix 12.4 for more details).

The *FireStingO2* is a high precision, compact USB-powered fiber-optic oxygen meter with 1, 2 or 4 channels for measurements in the laboratory. Additionally, one temperature sensor can be connected for automatic temperature compensation of the oxygen measurement. The integrated sensors for atmospheric pressure (mbar) and relative humidity (%RH) of the ambient air enable a precise and easy sensor calibration, as well as automatic pressure compensation of the oxygen measurements.

The *FireStingO2* is operated via a Micro-USB connection to a PC/tablet with a Windows operation system. The included logging software *Pyro Oxygen Logger* provides comfortable calibration and logging functionality.

The *FireStingO2* is a laboratory instrument, and if used in the field, please protect the *FireStingO2* from heating, moisture and corrosion.

The *FireStingO₂* comes with 1, 2, or 4 channels (connectors **1** to **4**) on the right side panel for up to 4 fiber-optic oxygen sensors and one connector (**T**) for a temperature sensor.



The Micro-USB connector on the left side panel provides the energy supply and the data exchange with the **PC**. Right-hand side of it, a connector X1 for power and digital interface (7-pins) and a connector X2 for analog output (5 pins) is located. The holes function as air inlets for the internal temperature, pressure and humidity sensors. Please avoid covering these holes to ensure free air circulation towards the internal sensors.



4 Software Installation

IMPORTANT: Do not connect the *FireStingO2* to your PC before the *Pyro Oxygen Logger* software has been installed. The software will install automatically the appropriate USB-drivers.

System requirements:

- PC with Windows XP/Vista/7/8 (but not Windows RT) and min. 200 MB free disk space

Installation steps:

- download the installer package for the newest version of the *Pyro Oxygen Logger* software from the *PyroScience* homepage: www.pyro-science.com/downloads.html
- unzip and start the installer and follow the instructions
- connect the *FireStingO2* with the Micro-USB cable to the computer. The red logo will flash shortly indicating the correct startup of the oxygen meter.

After the successful installation a new program group „Pyro Oxygen Logger“ is added to the start menu, and a short-cut named "Oxygen Logger" can be found on the desktop.

5 Oxygen Sensor Types

For an overview of all available oxygen sensor types, please see also: <http://www.pyro-science.com/overview-fiber-optic-oxygen-sensors.html>.

5.1 Needle-Type Sensors

The needle-type oxygen sensors are composed of a fiber-optical cable (C) with an ST-plug (P) for connection to the *FireStingO2* meter, a metal housing (H, fixed or retractable), and a syringe needle (N; 40 mm standard length) including the fiber with a fragile sensing tip and protected with a protective cap (PC). On each sensor, a specific Sensor Code (SC) is attached to the cable.



The oxygen-sensitive *REDFLASH indicator* is immobilized at the tip of the sensor, which can be retractable (R) or fixed (F) in the housing.

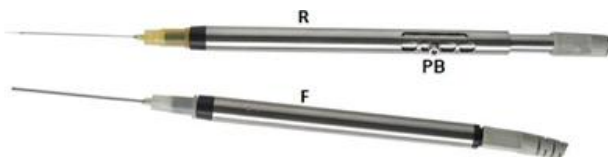

The needle-type oxygen sensors are offered with different tip diameters, including retractable microsensors with a tapered

sensor tip of ca. 40-60 μm in diameter (A) and minisensors with a flat sensor tip of 230 μm or 430 μm (B), as well as fixed minisensors with 0.5 mm and 1.1 mm tip diameter (C).

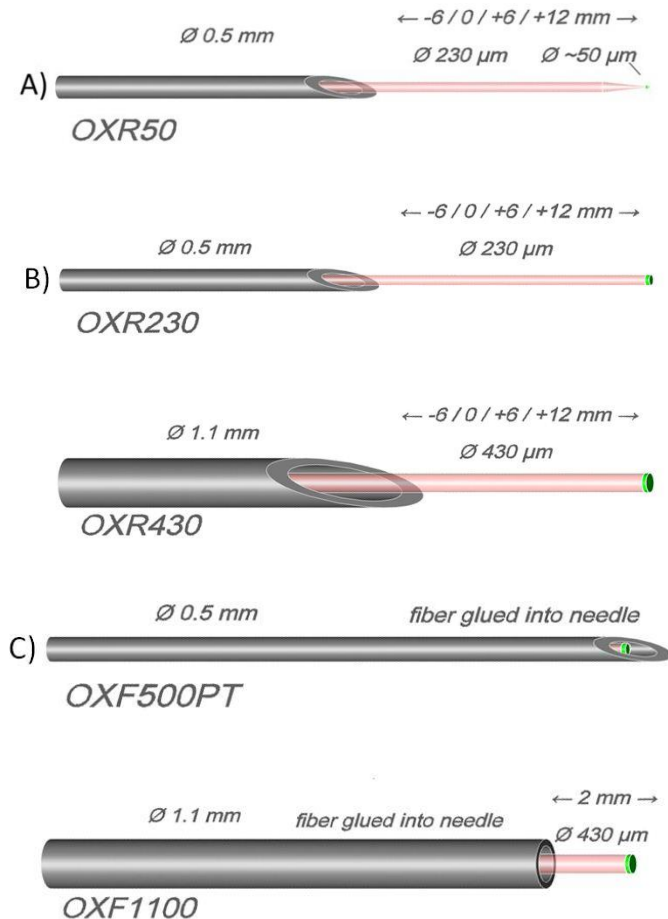

The **retractable sensors** are available as microsensors (*OXR50*; A) and as minisensors (*OXR230*, *OXR430*; B). The retractable sensor tip allows sensor insertion through septa or package material, and subsequent extension of the sensor tip into the sample for oxygen measurements. The sensors are shipped in

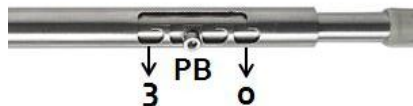

position o (retracted position) of the push button (**PB**) to protect the tip from breaking.

The protective cap (**PC**) covering the needle has to be removed carefully before using the sensor.

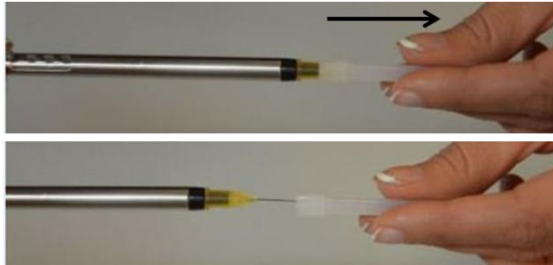

CAUTION: Remove only the protective cap, but not the needle!

Then the sensor should be fixed in a stable set-up like a solid laboratory stand or a micromanipulator mounted on a heavy stand from *PyroScience*. Move gently the push-button from the retracted position **o** to one of the extended **positions 1-3**. In **position 1** the sensor tip is flush with the needle tip, whereby in **positions 2** or **3** the fragile sensor tip extends ca. 6 mm or 12 mm out of the needle.

Please take care when handling the needle-type sensors to prevent injuries and breaking of the sensor. Ensure enough space in front of the fragile sensor tip, especially when pushing it out!

The needle-type **microsensors** (*OXR50; A*) are appropriate for high resolution measurements in semi-solid samples, like sediments, biofilms or soils with *PyroScience* turnkey motorized micro-profiling setups. They allow measurements in small sample volumes, along steep gradients and of depth-resolved oxygen profiles at high spatial resolution.

Please always use a stable stand and a micromanipulator to move the sensor into a semisolid sample like sediment, biofilm or soil.

The **minisensors** are standard sensors for robust long-term oxygen measurements in gaseous or aquatic environments. Fixed minisensors with a mechanically protected tip (*OXF500PT*; C) can be used for insertion through a rubber septum without addition of air to gas samples. Here the very sensor tip is flush with the tip of a beveled needle and glued into it.

In case of fixed minisensors with a tip diameter of 1.1 mm (*OXF1100*; C), the fixed sensor tip extends 1 mm from the needle tip and is hence unprotected after removal of the protective cap.

Avoid any contact to harsh surfaces!

The needle-type oxygen sensors are also optionally available with **optical isolation** for measurements in samples with autofluorescence. With this optical isolation, interferences between the *REDFLASH indicator* luminescence and autofluorescence, e.g. from photosynthetic pigments, are reduced. However, the optical isolation causes an increase in the response time t_{90} , which is the time for 90% of the total sensor signal change (see respective **Sensor Specifications**).

5.2 Bare Fiber Sensors

The bare fiber sensors are identical to the retractable needle-type oxygen sensors, except that they do not contain a housing. They comprise only the bare optical fiber with the *REDFLASH indicator* immobilized on the sensor tip,

secured during transportation and storage in a protective plastic tube (PT). The fiber-optical cable (C) is connected with the ST-plug



(P) to the oxygen meter *FireStingO2*. On each sensor, a label (L) with a specific Sensor Code is attached to the fiber-optic cable.



The protective plastic tube (PT) covering the bare fiber has to be removed carefully before using the sensor. For this, fix the plastic tube in a stable laboratory stand, loosen the clamping screw and carefully pull out the bare fiber sensor.

NOTE: After removal of the protective plastic tube the fragile sensor tip is unprotected and sensitive to breakage!

CAUTION during handling to avoid breakage or injuries!

The bare fiber sensors are available both as microsensors (OXB50; A) and as minisensors (OXB230, B; OXB430, C). They can be used with customized housings with complex geometries or they might be inserted directly into samples ("implantable sensors").



5.3 Robust Probes

The *Robust Oxygen Probes* are composed of a black fiber and a stainless steel tubing 3 mm in diameter, and 30 or 100 mm in length (e.g. item no. *OXROB3*, *OXROB10*). The oxygen sensitive part is the disc 3mm in diameter located at the very end of the tubing (green disc in image below).

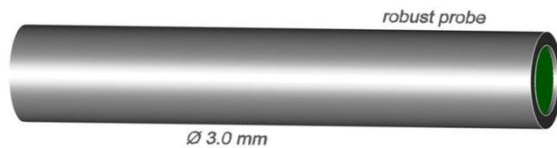

The *Robust Oxygen Probes* can be optionally obtained with an optical isolation (black coating) on the sensing surface (item no. *OXROB3-OI*, *OXROB10-OI*), which is recommended for applications with strong external illumination like direct sun light.



The *Robust Oxygen Probes* can be used for long-term measurements in gases and liquids. The whole sensor including its cabling is completely submersible in water and specified for longtime submersion in liquid media.

In contrast to the needle-type sensors, the sensitive sensor tip of the robust probe is protected by the steel tubing and is more robust for standard laboratory applications. Due to the significantly bigger dimensions of the robust probes compared to our micro- and minisensors, diffusion limitation in liquid samples of

oxygen towards the 3 mm tip has a measurable effect on the response time. For optimum operation conditions it is therefore recommended to utilize these robust probes in permanently stirred liquids (this diffusion limitation is negligible in gaseous samples; see also the respective sensor specifications).

Ensure that the complete sensing surface of the *Robust Oxygen Probe* is covered completely by the sample and prevent mechanical stress (e.g. scratching) to the sensing surface!

5.4 Sensor Spots

PyroScience offers a range of **contactless oxygen sensors**, comprising sensor spots, respiration vials and flow-through cells. The sensor spots are coated with the *REDFLASH indicator* with PET foil or glass as carrier material.

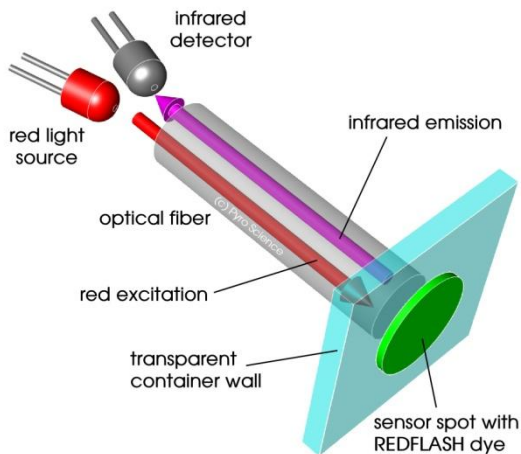

The sensor spots allow oxygen measurements in closed vessels in combination with the *FireStingO₂* equipped with *Optical Fibers* (e.g. item no. *SPFIB* or *SPFIB-CL₂*). The sensor spots have standard diameters of 5 mm (item no. *OXSP₅*) and can be optionally obtained with an optical isolation (black coating) on the sensing surface (e.g. item no. *OXSP₅OI*, *OXSG₈OI*). Optical isolation is recommended if strong illumination might disturb the measurement or if no light shall be introduced into the sample.





The sensor spots have a rough green sensing surface. Their backside is green smooth and shiny, and adheres on the adhesive side of the packaging (on which the sensor code is printed on the outside).

The sensor spots can be glued with their **backside** on transparent, clean and dry **inner** container walls (plastic or glass, wall thickness 0-6 mm) using an appropriate adhesive, like e.g. transparent silicone based on acetic acid (item no. *SPGLUE*). After the glue has dried, the gas or liquid sample has to be filled into the container so that the rough green sensing surface of the spot is completely covered and in contact with the sample.

For containers with **wall thicknesses of 0-2 mm**, the *Basic Spot Adapter* (a 10x10x10 mm plastic cube, item no. *SPADBAS*) needs to be fixed tightly or



glued to the outer container wall at the spot position. Then the sensor signal can be read out using the *Optical Fiber* (item no. *SPFIB* or the bare-fiber-version *SPFIB-BARE*) connecting the basic spot adapter with the *FireStingO2*.

For measurements through containers with **wall thicknesses of 2-6 mm**, the metallic *Lens Spot Adapter* (item no. *SPADLNS*) with an integrated collimating lens has to be used instead. It comes together with a flexible re-adjustable cable binder for quick positioning of spot adapters e.g. on laboratory flasks with a maximal diameter of ~10 cm.



Please note, that the *Lens Spot Adapter* does not work when submersed in water, because the integrated lens is working properly only in the gas phase. The spot adapter is then connected with the *Optical Fiber* (item no. *SPFIB*, *SPFIB-BARE*) to one channel of the *FireStingO2*.

It is important to fix or glue the spot adapter firmly to the outer container wall. **The position of the spot adapter should not be changed after calibration of the sensor spot (otherwise a re-calibration might be needed).**

The sensor spots offer a versatile field of application for multi-sampling measurements and online-monitoring of oxygen at greater scales. This includes the application in e.g. respiration and photosynthesis chambers, bioreactors, studies of enzyme kinetics, cell biological approaches and industrial process water-monitoring.

5.5 Flow-Through Cells

The flow-through cells have an integrated oxygen sensor, allowing online-monitoring of the oxygen content in a gas or liquid sample pumped through the cell. The flow-through cells are offered as a small version (item no. *OXFTC*) and as a large version (item no. *OXFTC2*). The attached tubing has an outer/inner diameter of ca. 2/1.5 mm for the *OXFTC* and of ca. 7/4 mm for the *OXFTC2*. The flow-through cells are equipped with luer-lock connectors on both tubing ends. A set of luer-lock adapters is included allowing the direct connection of gas-tight tubings with ca. 1.5-3.0 mm inner diameter to the *OXFTC* and ca. 4.0-5.5 mm to the *OXFTC2*.



The flow-through cell can be directly connected with the *Optical Fiber* (item no. *SPFIB* or *SPFIB-BARE*) to the *FireStingO2*.

CAUTION: For measurements in liquids, a flow rate of ca. 10-100 mL min⁻¹ is recommended for the *OXFTC* and of ca. 20-500 mL min⁻¹ for the *OXFTC2*!

5.6 Respiration Vials

Based on the contactless sensor technology from *Pyro Science*, ready assembled respiration vials with integrated oxygen sensors are available with 4ml or 20ml volume (item no. *OXVIAL₄* and *OXVIAL₂₀*),



respectively. Stripes of the oxygen sensitive *REDFLASH indicator* are glued to the inner wall of the respiration vials. Separately available adapter rings (item no. *ADVIAL₄* and *ADVIAL₂₀*) allow an easy fixation of a bare optical fiber (item no. *SPFIB-BARE* or *SPFIB-BARE-CL₂*), which connects the respiration vial to one channel of the *FireStingO₂*. The bare-fiber-versions of the optical fiber allow submersion in a water bath, as their fiber ends do not contain metallic parts potentially prone to corrosion. The position of the adapter rings (and the spot fiber) can be fixed by clamping screws. The elongated shape of the built-in sensor allows oxygen measurements at different heights within the vial by simply sliding the adapter rings up and down. Therefore it is e.g. possible to measure the oxygen content both in a liquid and in the gaseous headspace within the same vial.

For high precision respiration rate measurements, the respiration vials would be typically placed within a water bath with a regulated constant temperature at $\pm 0.1^\circ\text{C}$ precision. If higher temperature fluctuations are expected, the oxygen measurement should be automatically temperature compensated by connecting a temperature sensor (item no. *TDIP₁₅* or *TSUB₃₆*) to the *FireStingO₂* (see chapter 10) and placing it in the water bath.

The respiration vials can be used for small-scale respirometry and metabolic rate measurements of e.g. cell cultures, eggs, larvae, small crustaceans, small fish, water-, plant-, algal-samples etc.

5.7 Connecting the Sensors

The fiber-optic oxygen sensors, including needle-type and bare fiber micro- and minisensors, robust probes, as well as optical fibers needed for contactless sensors (sensor spots, flow-through cells, respiration vials) are connected to the ST-connectors of the *FireStingO2* (1 to 4) with a male fiber plug.

First, remove the black caps from the plug of the sensor/fiber.

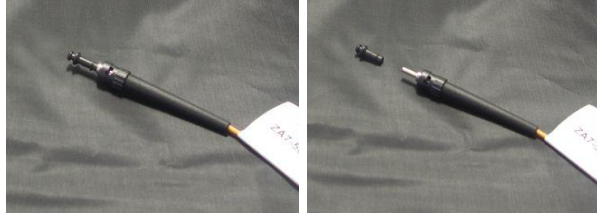

Remove the red caps from the receptacles at the *FireStingO2* (the red caps should be put on again if the *FireStingO2* is not in use anymore to protect the optics).



Then insert the male fiber plug (**M**) of the sensor cable into the ST-receptacle (female fiber connector) of the *FireStingO2* and turn the bayonet coupling gently clockwise until the plug is locked firmly.

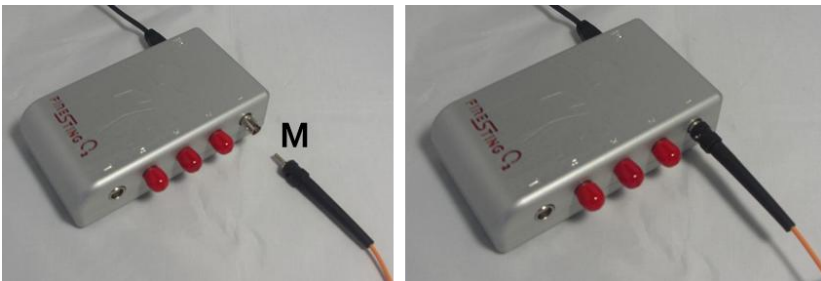

5.8 Cleaning and Maintenance of the Sensors

All oxygen sensors can be sterilized with ethylene oxide (EtO) and can be cleaned with peroxide (3% H₂O₂), soap solution or ethanol. They can be applied in gas phases, aqueous solutions, ethanol, methanol and isopropanol. Other organic solvents and gaseous chlorine (Cl₂) induce interferences with the sensor reading. No cross-sensitivity is found for pH 1-14, CO₂, CH₄, H₂S and any ionic species.

A signal drift of the sensor can indicate photobleaching of the oxygen-sensitive *REDFLASH indicator*, depending on the ambient light intensity, as well as the intensity of the excitation light and the sample frequency. This can necessitate a recalibration of the sensor and eventually also a readjustment of the **Sensor Settings** (LED intensity; see also chapter 6.2.2). In case of sensor spots, this could require a re-positioning of the optical fiber on the sensor spot and a subsequent new calibration. If the signal intensity is getting too low, as indicated by the horizontal indicator bar in the *Pyro Oxygen Logger* software and by the respective warning (see chapter 6), the sensor needs to be replaced.

A reasonable normal range oxygen sensor shows signal intensities well above 20 (typically 50-500).

After finalization of the measurements, the sensor tip of the needle-type and bare fiber oxygen sensors, as well as the robust probes should be rinsed carefully with demineralized water. Especially after application in seawater, it is recommended to clean the sensor thoroughly with demineralized water to prevent salt crystallization in the needle which can cause breaking of the sensor tip.

In case of retractable sensors, retract the sensor tip into the needle after drying. For all needle-type sensors, put on the protective cap onto the needle to protect the sensor tip and to avoid injuries.

The bare fiber sensors need to be secured in the delivered plastic tube or in any customized housing to protect the fragile sensor tip.

For the robust probes, put on carefully the small piece of plastic tubing onto the tip of the steel tubing to prevent any (destructive) impact on the sensor surface.

For all sensors and fibers, put the black caps on the plug of the fiber to prevent that light is entering the fiber possibly causing photo-bleaching of the *REDFLASH indicator*.

For sensor spots and respiration vials, wet cotton swabs can be used for cleaning to **carefully** wipe over the sensing surface. Rinse the sensing surface sufficiently with water afterwards to remove small particles and let it dry before storage.

Store the sensor in a dry, dark and secure place.

6 The Software “Pyro Oxygen Logger”

This chapter describes all functions of the *Pyro Oxygen Logger* software excluding the calibration. Please refer to the chapters 7 and 9 for a detailed description of the calibration procedure.

6.1 Main Window

After start of the software *Pyro Oxygen Logger* the following main window is shown:

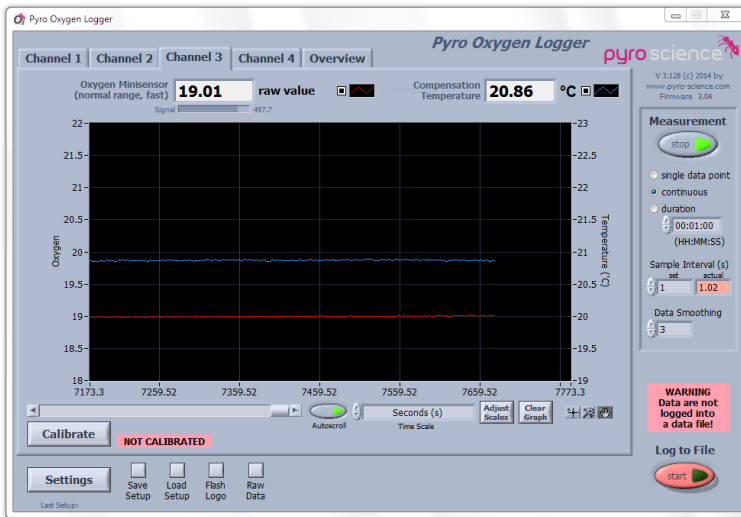

The four panels **Channel 1-4** correspond to the channels 1-4 of the fiber-optic oxygen sensors connected to the *FireStingO2*. For the 1- or 2-channel version of the *FireStingO2*, only the respective panels will be visible.

The default sensor readings show uncalibrated sensor readings (in raw value), which give only a qualitative information of the actual oxygen concentration.

Note that placing the mouse on many elements of the window will show a short description (“tool tip”). By clicking on the right mouse button and selecting “Description and Tip” a more detailed description might be available additionally.

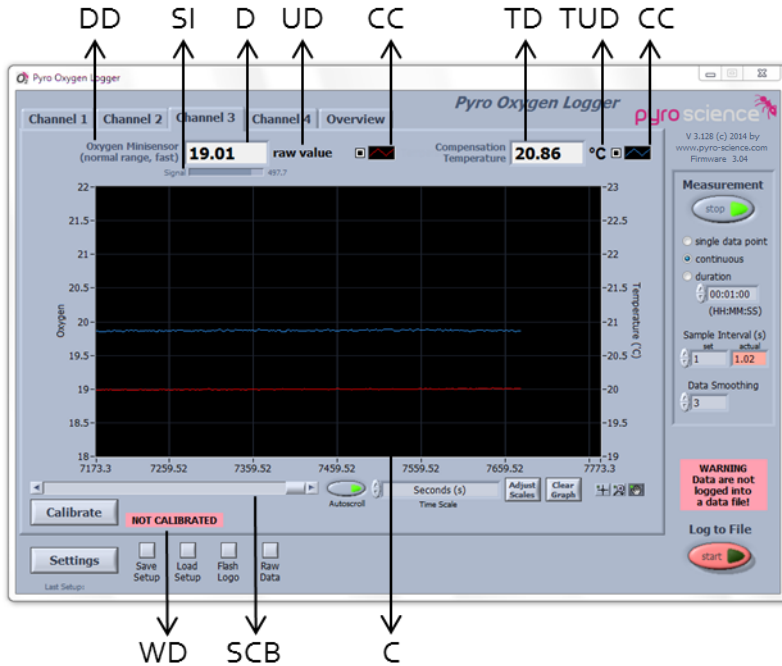

After the activation of the respective channels in the **Settings** (see chapter 6.2), the sensor readings of each channel are displayed in its corresponding panel in a numeric display (**D**) and in a chart recorder (**C**) in the chosen oxygen unit (**UD**). The color and appearance of each graph can be changed by clicking on the color-control (**CC**). The description of the sensor, as defined in the **Settings** by the **Sensor Code**, is shown in the description display (**DD**). The **Signal Intensity (SI)** of the oxygen sensor is shown as a horizontal indicator bar just underneath the numeric display (**D**).

A reasonable oxygen sensor shows signal intensities well above 20 (typically 50-500)¹. If the signal intensity drops below 50, this indicator bar turns gradually from grey to red indicating that the sensor might get degraded soon. Most sensors will still work even at a signal intensity of ca. 10 (yet with increased noise). But at even lower signal intensities the warning **Low signal** will appear in the warning display (**WD**) (see below and chapter 12.3).

Note that the signal intensity can be influenced by varying the **LED Intensity** or the **Amplification** in the advanced settings (see chapter 6.2.2).

The actual **Compensation Temperature** (see chapter 10) is shown in the temperature display (**TD**) in units of **degree Celsius (°C)**. **NaN** denotes **Not a Number** when no temperature sensor is connected or if it is not activated in the **Settings** (see chapter 6.2.4).

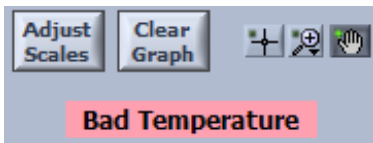

A warning **Bad Temperature** appears below the chart recorder if the temperature sensor is activated, but not connected.

The display of the data in the charts can be changed by different chart tools arranged underneath the chart recorder.

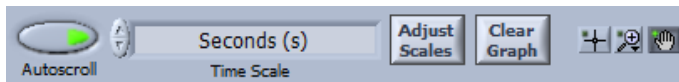

The button with the magnifying glass offers different zoom options. After clicking the button with the hand, the user has the possibility to click onto the chart and move the whole area while keeping the mouse button pressed.

¹ Note: Exceptions are trace oxygen sensors. During the 100%-calibration at 21% O₂, these sensors show naturally a very low signal intensity (as low as 10). But the signal intensity will strongly increase when a trace oxygen sensor is applied within its specified range of 0-10% O₂.

The unit of the x-axis can be changed with the selector **Time Scale** (using the arrows or clicking onto the field). The time scale can be displayed in Seconds (s), Minutes (min), Hours (h), Relative Time (HH:MM:SS), Absolute Time (HH:MM:SS), Absolute Time and Date and in Data Points.

The scales of the x-axis (Time) and of the y-axes, on the left side for oxygen and on the right side for temperature (if a temperature sensor is connected and activated), can be adjusted by clicking on **Adjust Scales**, opening a pop-up window:

The upper (**Maximum**) and lower limits (**Minimum**) and the **Increment** of the **Y Scales Oxygen** and **Temperature** and of the **X Scale (Time)** can be changed by clicking on the respective selector or by double-clicking directly onto the field and entering the values manually (changing these parameters will automatically de-activate the

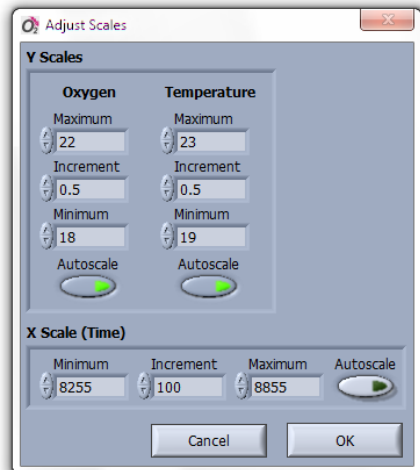

autoscaling). Autoscaling for all axes can be activated with the **Autoscale** button. The arrow in the button turns from dark green to light green indicating that Autoscale is activated. By default only the y-axis oxygen is in Autoscale mode.

The button **Clear Graph** offers the options to clear only the graph of one channel, or to clear the graphs of all channels (i.e. the graphs in all other panels will be also cleared). Note, that this will not affect the saved data in the data file.

All data recorded can be displayed in the chart recorder by moving the bar along the scroll bar (**SCB**). Switching off the **Autoscroll**

button will allow inspection of older data which are not displayed anymore in the actual graph, e.g. during longtime measurements.

The **Plot Style** of the charts can be changed by clicking with the right mouse button onto the black field of the respective color control (CC)  above the chart recorder, opening a pop-up menu. With **Common Plots, Color, Line Style and Width, Interpolation,** and **Point Style** the chart appearance can be changed. By clicking on the small rectangular button of the color control (CC), it is possible to show or hide the respective graph.

If a sensor is not yet calibrated, the warning **Not Calibrated** is shown on the right-hand side of the **Calibrate** button. As long as the sensors are not calibrated, the data are shown in units of “raw value” reflecting only qualitatively the measured

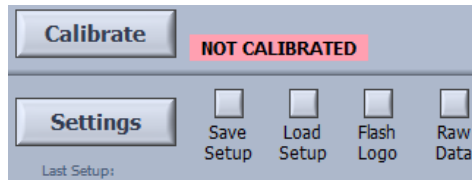

oxygen levels. In order to switch to quantitative oxygen units, a calibration has to be performed by clicking on the button **Calibrate**. The calibration procedure is explained in detail in chapter 7.

The warning display (**WD**) can show the following warnings:

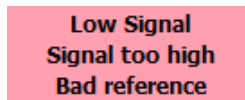

Low signal — The sensor is either not connected or needs to be replaced by a new one. In case of contactless sensors it might indicate that the distance between the optical fiber and the sensor spot is too large. (For advanced users: increase the LED intensity and/or the amplification in the Advanced Settings).

Signal too high — There might be too much ambient light on the sensor tip or the sensor spot. Avoid direct sun light exposure or strong direct illumination with a lamp. (For advanced users: decrease the LED intensity and/or the amplification in the Advanced Settings)

Bad reference — This indicates internal problems of the *FireStingO2*. Please contact *PyroScience* for support.

Refer also to Troubleshooting in chapter 12.3.

The adjustment of the Settings using the button **Settings** is described in detail in chapter 6.2.

The button **Save Setup** can be used to save the current settings and calibration data of all channels. They can be reloaded anytime by pressing the button **Load Setup**. This allows e.g. to switch between different laboratory setups with a single *FireStingO2*. This function might be also useful if different computers are used for the calibration and for the actual measurements. You might calibrate the sensors with the first computer, save the configuration with **Save Setup**. By transferring this file and also the oxygen meter *FireStingO2* to a second computer, you can load there again this configuration with **Load Setup** giving you calibrated sensors ready for the measurement.

Save Setup and **Load Setup** might be also useful if e.g. a 1-channel *FireStingO2* should be used repeatedly with several oxygen sensors. Initially each sensor needs to be calibrated only once and the configuration of each sensor is saved with **Save Setup**. If later on a measurement should be performed with a specific sensor, it is only necessary to load the configuration for this sensor with **Load Setup**.

Note, that all current settings and calibration data are automatically saved when closing the *Pyro Oxygen Logger* software (by clicking on the cross in the upper right corner of the main window), and are automatically loaded again at the next startup.

The button **Flash Logo** causes a short flashing of the illuminated logo of the *FireStingO2* meter. Several *FireStingO2* meters can be connected to the PC in parallel and multiple measurements can be performed by opening the *Pyro Oxygen Logger* software a number of times corresponding to the number of connected *FireStingO2* meters. The different windows operate completely independent of each other and are assigned to exactly one *FireStingO2*. This allows measurements in different setups at the same time. The flashing of the logo (for ca. 1 sec after pressing the **Flash Logo** button) can help to assign a specific logger window to the corresponding *FireStingO2* meter (more details in chapter o).

Clicking on **Raw Data** opens a pop-up window **FireSting Raw Data** which is described in chapter 6.4.

A **Measurement** is started by clicking on the measurement start button (**MSB**) on the right-hand side. The arrow in the button turns from dark green to light green indicating that a measurement is in progress. Clicking again on it will stop the measurement.

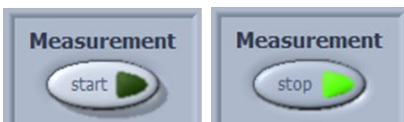

The mode of **Measurement** can be chosen as **single data point** acquisition,

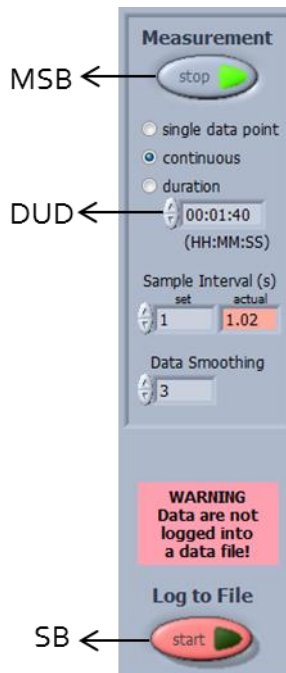

continuous sampling (default setting) or as continuous sampling limited to a defined time interval. The **duration** of the time interval can be adjusted in the duration display (**DUD**) shown as hour (HH): minutes (MM): seconds (SS). The **Sample Interval (s)** for continuous sampling can be defined in the field designed with **set**. Setting the sample interval to 0.25 will give the maximal possible scan rate. The exact maximal rate depends on the settings and the number of activated channels. The actual sample interval is shown in the display **actual** and is displayed in red if the actual is not equal the set sample interval.

The acquired data can be smoothed by a **Data Smoothing** (range 1..10, **default**: 3, a value of 1 means no data smoothing). For **continuous** or **duration** measurements with a sample interval < 10 s, data smoothing is done by a simple running average (e.g. with **Data Smoothing**=5 always the last 5 sampled data points are averaged). However, for **single data point** measurements and for **continuous** or **duration** measurements with sample intervals > 10 s, the data smoothing is done by averaging repetitive measurements (e.g. with **Data Smoothing**=3 for each data point 3 oxygen measurements are performed as fast as possible sequentially, and the average of these 3 measurements is displayed as the new data point).

IMPORTANT: By default the displayed data are not automatically saved to a file.

To activate data saving, click on the red **start** button (**SB**) of **Log to File**. Select a file name in the appearing file dialog. The saved data files are simple text-files with the file extension ".txt", which can be easily imported into common spreadsheet programs.

Thereafter, the indicators **Comment** and **File Path** are additionally shown in the main window. In the field

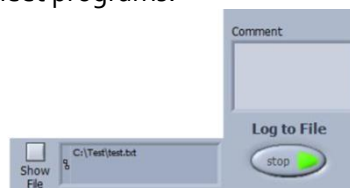

Comment, the measurements can be commented and this comment is then saved together with the next data point into the data file.

During data logging, the data file can be displayed and opened by clicking on the button **Show File**. The data saving is indicated by the light green arrow in the grey **Log to File** button and can be stopped by clicking this button again.

NOTE: During data logging, the buttons **Settings** and **Calibrate** are not active and cannot be used before **Log to File** is stopped.

6.2 Settings

To open the dialog window **FireSting Settings** click on **Settings** in the Main Window:

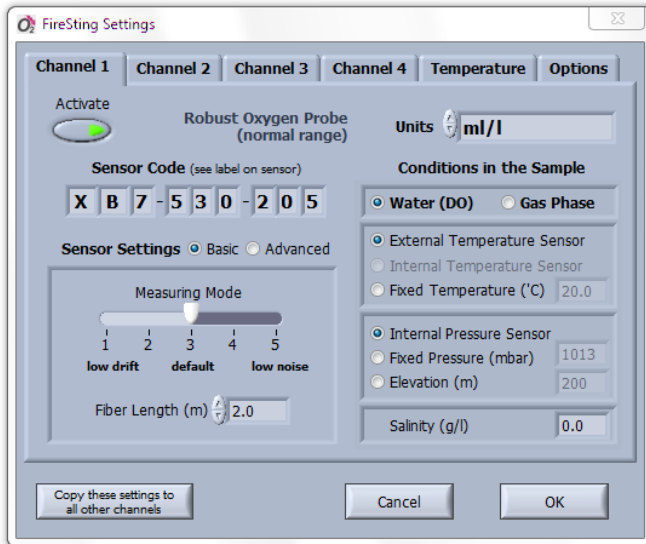

Settings can only be adjusted if data logging is **not** active.

In the settings the user has to define for each channel (1) the **Sensor Settings** and (2) also the environmental **Conditions in the Sample** under investigation.

Each oxygen channel of the *FireStingO2* meter has its own tab in the **FireSting Settings** window. By clicking on **Copy these Settings**, all settings adjusted in the active channel tab can be pasted to all other channels.

The channels can be activated independently by clicking on the button **Activate**. Activation is indicated by a change from dark to light green of the arrow in the button. A text describing the connected sensor type appears on the right-hand side of this button after the **Sensor Code** (see label on sensor) has been entered. This description will be shown in the description display (**DD**) of the main window and also in the data file.

Please take care that the sensor code attached to the sensor of a specific channel of the *FireStingO2* is entered into the field **Sensor Code** in the same channel panel in the window **Settings**. It includes information for optimal sensor settings and for calibration data needed for the factory and 1-point calibration. The first letter of the sensor code defines the sensor type. A detailed explanation of the sensor code is given in chapter 12.8.

The oxygen units can be selected for each channel by the selector **Units**. The selectable units include raw value (default), %air saturation, %O₂, mL L⁻¹, μmol L⁻¹, mg L⁻¹ (ppm), hPa (mbar), mmHg (Torr), dphi and μg L⁻¹ (ppb). For measurements in a **Gas Phase** only the units raw value, %O₂, hPa (mbar), mmHg (Torr) and dphi can be selected, whereas for measurements of dissolved oxygen in a **Water** sample (**DO**) all units except %O₂ can be selected. For detailed information please refer to chapter 12.6.

NOTE: The Charts are automatically cleared in the panels of the **Main Window** after the **Settings** have been modified. Re-adjustments in the **Settings** might require also a recalibration of the sensor(s).

If the changes of the Settings require a sensor recalibration, a warning **Not Calibrated** appears right-hand side of the **Calibrate** button in the corresponding channel panel of the Main Window.

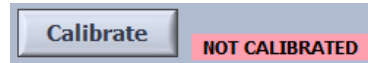

6.2.1 Basic Settings

The **Sensor Settings** can be adjusted in a **Basic** or an **Advanced** mode. The first-time user is advised to work with the **Basic Settings**. Please ensure that the correct sensor code attached to the sensor has been entered in the field **Sensor Code**.

For contactless sensors (sensor spots, flow-through cells, respiration vials; sensor type: S, W, T) and for robust probes (sensor type: X), additionally the **Fiber Length (m)** of the connected optical fiber (e.g. *SPFIB*) or of the connected robust probe (e.g. *OXROB10*) must be entered (for interested users: the entered fiber length is used for an automatic background compensation; refer to chapter 9.2 for more details).

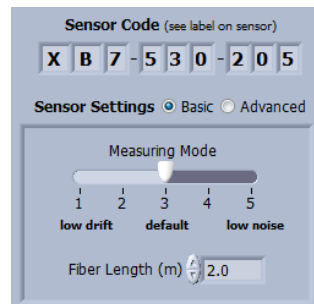

The **Measuring Mode** can be adjusted gradually between low drift (1) and low noise (5) of the sensor signal by moving the arrow with the mouse along the scale, thereby changing the oxygen measuring time. An intermediate mode (3) is default.

NOTE: Ensure that the correct sensor code has been entered. If the sensor is not yet calibrated, a warning **Not Calibrated** is displayed in the Main Window.

6.2.2 Advanced Settings

If **Advanced Sensor Settings** are chosen, more complex setting controls get visible. Please ensure that the correct sensor code attached to the sensor has been entered in the field **Sensor Code**.

For robust probes (sensor type: X), the **Fiber Length (m)** of the connected robust probe must be entered.

For contactless sensors (sensor spots, flow-through cells, respiration vials; sensor type: S, W, T), the **Fiber Length (m)** of the connected optical fiber must be entered. Alternatively, it is possible to select **Manual Background Compensation**, which is described in detail in chapter 9.2. Finally, the background compensation can be completely de-activated by selecting **No Background Compensation**.

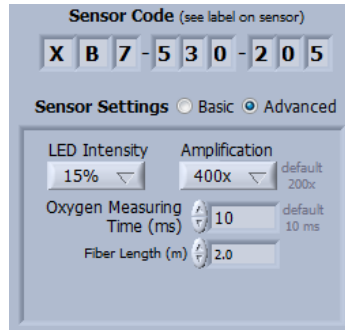

Sensor Code (see label on sensor)
X B 7 - 5 3 0 - 2 0 5

Sensor Settings Basic Advanced

LED Intensity 15% ▾ Amplification 400x ▾ default 200x

Oxygen Measuring Time (ms) 10 ▾ default 10 ms

Fiber Length (m) 2.0 ▾

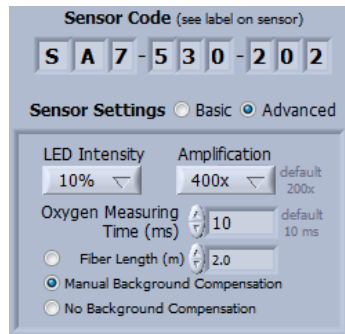

Sensor Code (see label on sensor)
S A 7 - 5 3 0 - 2 0 2

Sensor Settings Basic Advanced

LED Intensity 10% ▾ Amplification 400x ▾ default 200x

Oxygen Measuring Time (ms) 10 ▾ default 10 ms

Fiber Length (m) 2.0 ▾

Manual Background Compensation

No Background Compensation

NOTE: Generally it is advised to select **Fiber Length (m)** and to enter there the fiber length. The alternative options **Manual Background Compensation** or **No Background Compensation** are only intended for advanced users (see also chapter 9.2).

The **Advanced Measuring Parameters** comprise the **LED Intensity** for excitation of the **REDFLASH indicator** (in %) and the **Amplification** of the sensor signal (default: 200x). As a rule of thumb, the **LED Intensity** should be 10-30% for microsensors, minisensors and robust probes, but can be increased up to 100% for contactless sensors (sensor spots, flow-through cells, respiration vials). The **Amplification** should be typically chosen as

80x, 200x or 400x. Note, that varying the LED Intensity and the Amplification has direct influence on the signal intensity and therefore on the signal-to-noise-ratio.

The **Oxygen Measuring Time** (default: 10 ms) defines the integration time for the acquisition of a single data point. Shorter measuring times provide low long-term drift, whereby longer measuring times assure less noise. The maximal possible value is 250 ms.

NOTE: If using the **Advanced Sensor Settings**, it is recommended to perform a **2-Point** calibration of the oxygen sensor. Later re-adjustments in the **Advanced Settings** might require also a recalibration of the sensor.

6.2.3 Conditions in the Sample

The next step is the determination of the **Conditions in the Sample**, which can be **Water** for dissolved oxygen (DO) or a **Gas Phase**.

Further, it needs to be selected if during the measurements the temperature will be determined by the **External Temperature Sensor** connected to the *FireStingO2*, by the **Internal Temperature Sensor** of the *FireStingO2* (only possible for measurements in a Gas Phase!) or if measurements are performed at a **Fixed Temperature** (see chapter 10).

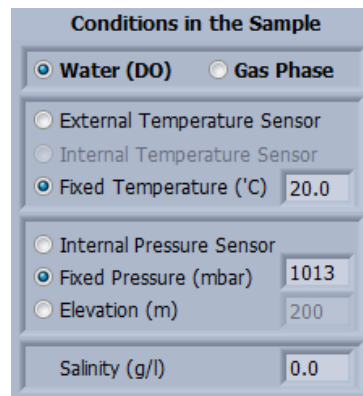

The screenshot shows a settings window titled "Conditions in the Sample". It features two main sections: "Water (DO)" and "Gas Phase". Under "Water (DO)", there are three radio button options: "External Temperature Sensor", "Internal Temperature Sensor", and "Fixed Temperature ('C)" with a value of 20.0. Under "Gas Phase", there are three radio button options: "Internal Pressure Sensor", "Fixed Pressure (mbar)" with a value of 1013, and "Elevation (m)" with a value of 200. At the bottom, there is a "Salinity (g/l)" field with a value of 0.0.

If **External Temperature Sensor** or **Internal Temperature Sensor** (in a Gas Phase) is selected, automatic temperature compensation

of the respective oxygen sensor readings is activated (see chapter 10.3). Please note that if **External Temperature Sensor** or **Internal Temperature Sensor** is chosen in one of the 4 oxygen **Channel** panels of **FireSting Settings**, the temperature sensor connected to the *FireStingO2* or the internal temperature sensor of the *FireStingO2* is automatically activated in the **Temperature** panel of the **Settings** (see chapter 6.2.4).

Please ensure that the external temperature sensor is fixed in the container with the sample in which the oxygen measurements with automatic temperature compensation will be performed. If internal temperature sensor was selected, please ensure the same temperature conditions for the gas sample and the *FireStingO2*.

If **Fixed Temperature** is chosen, the temperature of the environmental sample has to be determined with an external thermometer or with a temperature sensor from *PyroScience* connected to the *FireStingO2*, and has to be adjusted manually.

This **Compensation Temperature**, either entered manually at constant temperature conditions or measured by the external or internal temperature sensor of the *FireStingO2*, will be displayed in the corresponding channel panel of the main window (**TD**).

The atmospheric pressure can be determined with the **Internal Pressure Sensor** or entered manually at **Fixed Pressure (mbar)** conditions (needs to be controlled with a barometer or the internal pressure sensor). Normal conditions refer to 1013 mbar (default).

If the actual atmospheric pressure cannot be determined on site, it is also possible to enter the **Elevation (m)** above sea level. For this click on **Elevation** and enter the actual elevation in meters. This procedure will only calculate the average atmospheric pressure for this elevation; therefore this option is less precise than measuring the actual atmospheric pressure. If **Internal Pressure Sensor** is

selected, the oxygen measurement is automatically compensated for pressure changes e.g. due to weather changes.

The **Salinity (g/L)** of the environmental sample, in which the measurements are performed, needs to be adjusted e.g. in case of saline water. For measurements in gas samples this value has no relevance (and is not active). For measurements in liquid samples, the salinity is only relevant if a concentration unit for oxygen was selected (e.g. mg/L or $\mu\text{M/L}$).

6.2.4 Temperature

An **External Temperature Sensor** connected to the *FireStingO2* and the **Internal Temperature Sensor** inside the *FireStingO2* can be activated in the panel **Temperature**. Both temperature sensors can be activated independently even if the oxygen measurements of all sensors are performed with **Fixed Temperature** (and hence are not affected by the temperature sensor measurements). The measured temperature is then displayed in the **Overview** panel (see chapter o) of the main window and saved into the data file.

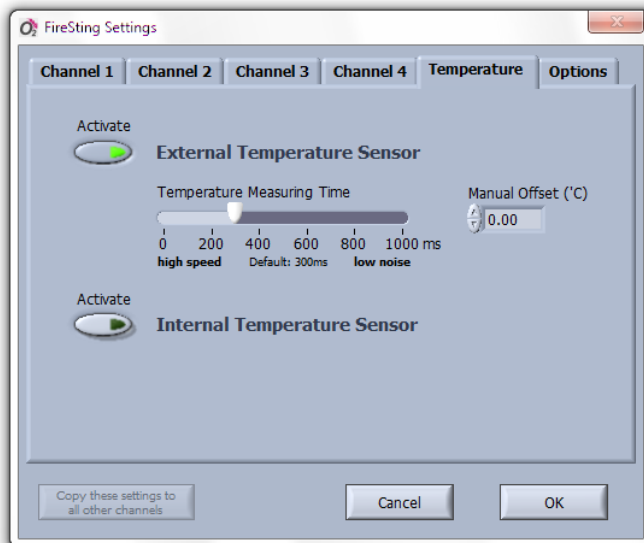

After activation of a temperature sensor in the oxygen channels (see 6.2.3), the measured temperature by the external or internal temperature sensor is displayed in the panel(s) of the corresponding oxygen sensors with activated automatic temperature compensation (right-hand side y-axis). It is also displayed in the **Overview** panel (see chapter 6) of the main window and saved into the data file.

The temperature is displayed in units of degree Celsius (°C).

The **Temperature Measuring Time** (default 300 ms; only multiples of 100ms possible) of the **External Temperature Sensor** can be optionally (a) increased in order to reduce the noise of the temperature measurement or (b) decreased in order to achieve higher sampling rates.

A **Manual Offset** of the External Temperature Sensor might be entered for possible recalibration of the temperature sensor (default: 0).

Please note that each *FireStingO2* meter provides only a single port for a temperature sensor. For **Automatic Temperature Compensation** (see chapter 6.2) of >1 oxygen sensor, all sensors with automatic temperature compensation have to measure at the same temperature condition, as determined with the connected external temperature sensor (see also chapter 10). Alternatively, if the temperature extension module *TeX4* is coupled to the *FireStingO2*, then automatic temperature compensation can be performed for each channel independently using the temperature sensor connected to the corresponding port of the *TeX4*.

6.2.5 Options

In the panel **Options**, several internal sensors and an **Analog In** can be activated. The **Internal Pressure Sensor** and the **Internal Humidity Sensor** inside the *FireStingO2* can be independently activated by clicking on the respective buttons and are displayed in the **Overview** panel (see chapter o) of the main window and saved into the data file. If the **Internal Pressure Sensor** of the *FireStingO2* was activated in one of the oxygen channels (see 6.2.3), it is automatically activated in the **Options** panel.

It is possible to designate a specific name to the connected *FireStingO2* in **Device Description** e.g. "Water Container Nr.42". This device description is then indicated in the top line of the main window. This option is especially useful if several *FireStingO2* devices are operated in parallel in order to distinguish the opened logger windows.

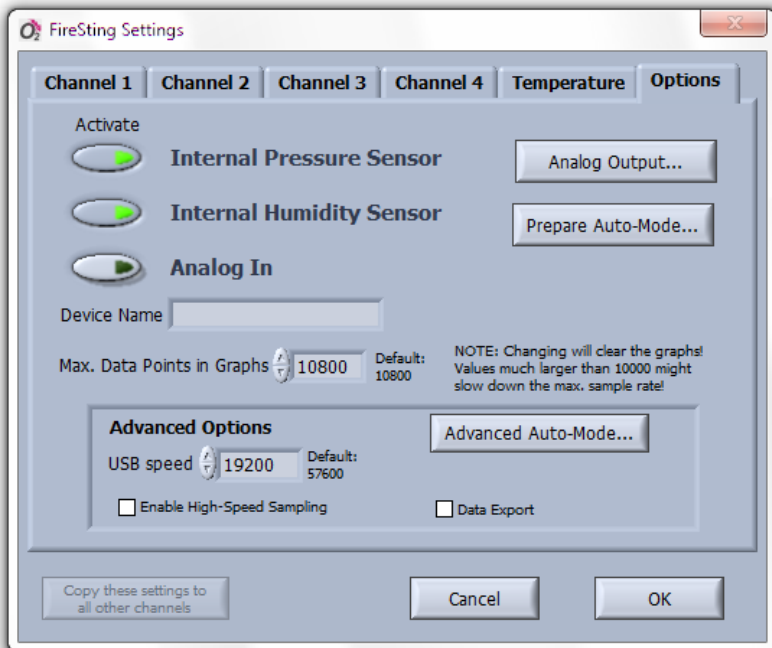

The activation of the **Analog In** button allows to read in a voltage signal at the extension port, e.g. from third-party sensors like a pH sensor. The measuring range is 0-2.5V and the display and output of the signal is in mV. For details refer to chapter 11.

The maximum number of data points kept in the graphs can be changed by the selector **Max. Data Points in Graphs** (default: 10800). A change of the number will clear the graphs and high values (>>10000) might decrease the maximum sample rate.

The *FireStingO2* offers four analog outputs (0-2.5V) at the extension port which can be configured by pressing the **Analog Output** button. For details refer to chapter 11.

Advanced Options (only for advanced users)!

The **USB** communication **speed** can be adjusted e.g. for improving the maximum sampling rate (default: 57600).

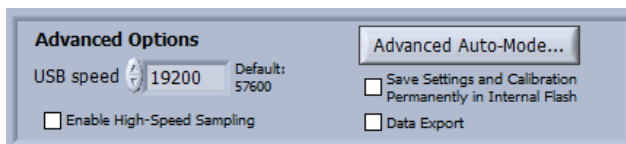

Activation of the button **Enable High-Speed Sampling** will enable the adjustment of a Sample Interval <0.25 s in the main window (and disable **Max. Data Points in Graph**).

The **Advanced Auto-Mode** button allows advanced configuration options for the Auto-Mode. For details refer to chapter 11.

6.3 Overview Panel

The sensor readings of all activated oxygen sensors (left y-axis), external and internal temperature sensors, internal pressure and humidity sensors (right y-axis) and signals from the Analog In (left y-axis) are displayed in the panel **Overview**.

Each sensor reading is shown also as a numerical value in the chosen unit on top of the overview graph. The plot style of each channel in the chart can be changed by clicking on the color control:



By clicking on the small rectangular button of the color control, it is possible to show or hide the respective graph. This show/hide functionality is especially useful, if e.g. a single graph should be inspected in detail while all other graphs are hidden.

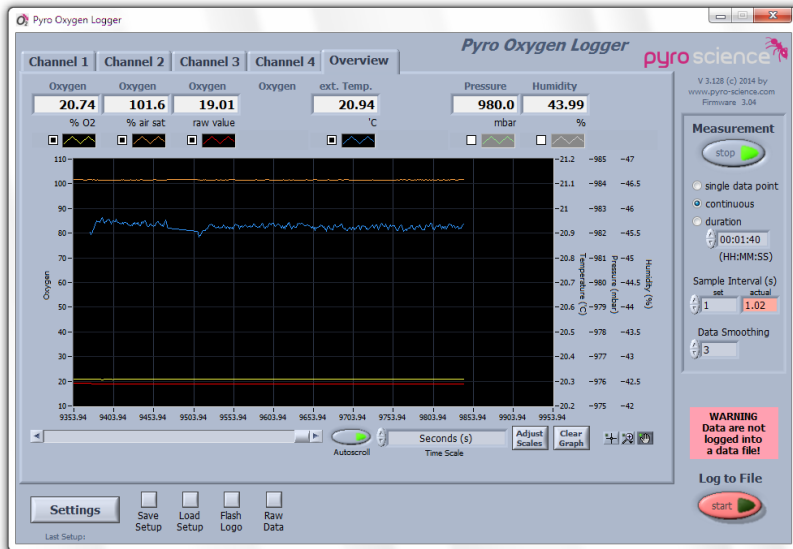

With Common Plots, Color, Line Style and Width, Interpolation and Point Style each plot in the chart can be changed. The items Bar Plots, Fill BaseLine, and Y-Scale are not appropriate for this application.

6.4 Raw Data Window

The Raw Data Window is mostly intended for trouble shooting and advanced users. During normal measurements it is in general not needed. After clicking on the **Raw Data** button in the **Main Window** (see chapter 6.1) the following **Oxygen Sensor Raw Data** window opens:

NOTE: While the Raw Data window is opened, all raw values are also saved into the data file in additional columns behind the standard data columns.

The panels of each oxygen channel (**Chan 1-4**) show the phase shift as "delta phi" (**dphi**, in °). **dphi** is the actual measured raw value which is used for the internal calculation of the oxygen concentration **Oxygen (μM)**, **Oxygen** partial pressure (**hPa**), **Oxygen** in % air saturation (**% air sat**) and **Oxygen (% O₂)** (see also chapter 12.4).

The **Signal Intensity** (in mV) gives a measure of the quality of the oxygen measurement, which is also displayed in the horizontal bar indicator in the main window (see chapter 6.1).

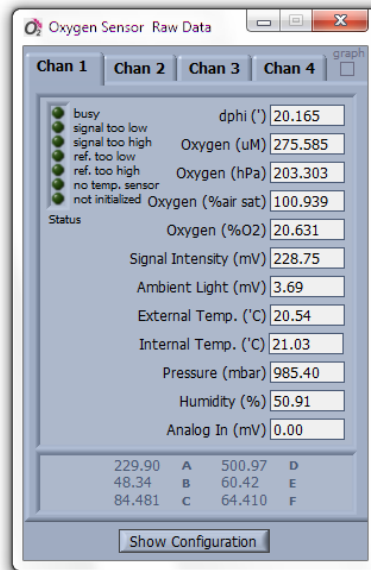

Ambient Light (in mV) gives a measure of the ambient light entering the sensor from outside. At too high ambient light levels the detector of the *FireStingO₂* might get saturated giving the warning **Signal too high** in this window and in the warning display of the main window (see chapter 6.1).

The temperature measured by the connected external temperature sensor (**External Temp. (°C)**) and the internal temperature sensor (**Internal Temp. (°C)**) in the *FireStingO2* meter, the **Pressure (mbar)** and **Humidity (%)** measured by the internal sensors inside the *FireStingO2*, as well as the **Analog In (mV)** are also displayed.

On the left side, the **Status** and different warnings can be indicated by the software concerning the signal and reference intensity (too low, too high) and the detection of the temperature sensor.

On the right-hand side of the channel tabs, a **graph** can be activated, showing the dphi (°) and Signal Intensity (mV) in the graph (default setting). Plotting of additional parameters can be activated by clicking on the small rectangular button next to the color control of the respective parameter.

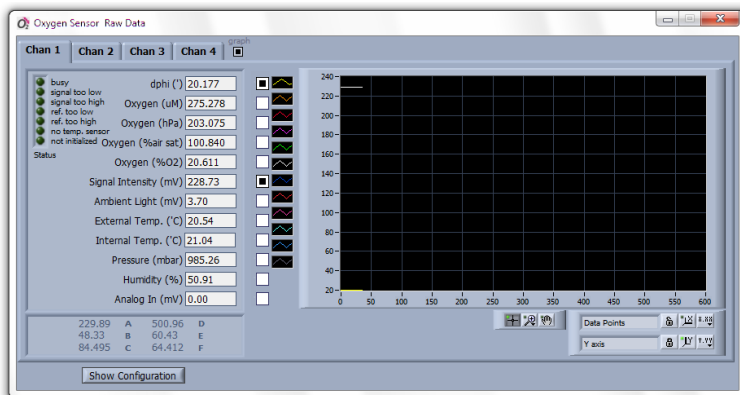

7 Calibration with “Pyro Oxygen Logger”

This chapter describes the possible calibration modes for oxygen sensors using the logger software “*Pyro Oxygen Logger*”. Please note that the possible calibration modes differ depending on the connected *FireStingO2* device:

If your device has integrated humidity and pressure sensors (e.g. *FireStingO2* devices with **micro-USB** connector, firmware >3.0) proceed with chapter 7.1.

If your device does not possess integrated humidity and pressure sensors (e.g. *FireStingO2* devices with **classical full-size USB** connector, firmware 2.30), then proceed with chapter 7.2.

For many calibration modes, the atmospheric pressure and the relative humidity of the ambient air are important parameters ensuring a high precision of the calibration. Formerly it was on the user’s authority to measure and adjust manually these parameters. But the *FireStingO2* devices come with integrated pressure and humidity sensors, which measure these parameters now automatically, ensuring a straightforward calibration procedure and eliminating many possible error sources.

This chapter covers only the necessary steps during the calibration procedure. For details regarding the preparation of the calibration standards refer to chapter 8.

7.1 Calibration Procedure

Before starting the calibration, ensure that the correct **Sensor Code** has been entered in the settings (refer to chapter 6.2).

To calibrate a sensor click on the button **Calibrate** in the corresponding channel panel. Note that during data logging this button cannot be used until **Log to File** was **stopped**.

A dialog window **Oxygen Sensor Calibration** opens in which the calibration mode for the corresponding channel can be selected:

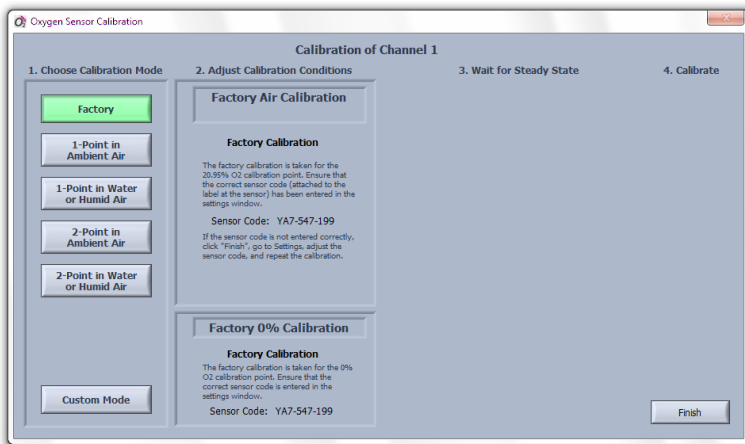

Five *standard modes* can be chosen for the calibration:

Factory calibration (for a quick, rough calibration): taking the 0% and the air calibration values from the sensor code, advised only for rough measurements.

1-Point in Ambient Air: taking the 0% calibration value from the sensor code and the air calibration value from a manual calibration in ambient air for precise measurements around 21% O₂.

1-Point in Water or Humid Air: taking the 0% calibration value from the sensor code and the air calibration value from a manual

calibration in air saturated water or water-vapor saturated air for precise measurements around 100% air saturation.

2-Point in Ambient Air: taking the 0% and the air calibration value from a manual calibration for precise measurements over the full range (0-21% O₂). This mode uses the ambient air for determining the air calibration value.

2-Point in Water or Humid Air: taking the 0% and the air calibration value from a manual calibration for precise measurements over the full range (0-100% dissolved O₂ (DO)). This mode uses air saturated water or water-vapor saturated air for determining the air calibration value.

NOTE: It is recommended to determine the air calibration value in air saturated water if the measurements will be performed in water samples (aqueous liquids).

During the calibration of a sensor connected to a specific channel, the **Sample Interval** is automatically set to 0.5 s and the **Data Smoothing** to 5, ensuring a fast determination of a precise mean value during the sensor calibration. After finalization of the calibration, the program returns automatically to the former settings.

For advanced users and applications, a **Custom Mode** can be selected, allowing the user to combine freely the possible calibration types for the air and the 0% calibration.

Possible Air Calibration Types in the Custom Mode:

- **Air with 100% Humidity or Air Saturated Water,**
- **Ambient Air,**
- **Custom Calibration** (allowing also calibrations at freely chosen oxygen levels)
- **Factory Air Calibration.**

Possible 0% Calibration Types in the Custom Mode:

- a manual 0% Calibration
- a Factory 0% Calibration.

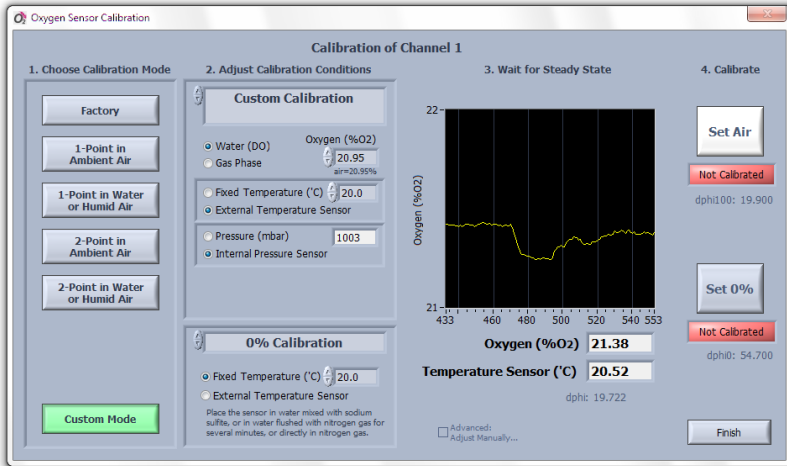

In the following the different calibration modes are described.

7.1.1 Calibration Mode: Factory

NOTE: The Factory Calibration is intended only for rough measurements and testing purposes. It is only possible if the correct Sensor Code has been entered in the Settings (see chapter 6.2).

If the calibration mode **Factory Calibration** is chosen, ensure that the correct sensor code has been entered in the **Settings** of the corresponding channel (as displayed in 2. **Adjust Calibration Conditions** of the **Oxygen Sensor Calibration** window). If the sensor code displayed is not correct, click on **Finish**, go to the **Settings**, enter the correct **Sensor Code** and repeat the **Factory Calibration**.

If the Sensor code is correct, the factory calibration is completed by clicking on **Finish**, thereby returning to the main window of the corresponding channel.

7.1.2 Calibration Mode: 1-Point in Ambient Air

NOTE: The calibration **1-Point in Ambient Air** is only possible if the **correct Sensor Code** has been entered in the **Settings** (see chapter 6.2).

The calibration mode 1-Point in Ambient Air is selected by clicking on the button **1-Point in Ambient Air**. This mode uses the ambient air for determining the air calibration value. The 0% calibration value is taken from the **Sensor Code**.

Because this calibration mode will automatically read the atmospheric pressure and the relative humidity from the internal pressure and humidity sensors, it is important that both the *FireStingO2* device and the connected oxygen sensor are exposed to identical environmental conditions.

If possible, **position the oxygen sensor and the external temperature sensor (if used) close to the air holes** at the backside of the *FireStingO2*. Ensure that the **oxygen sensor and the external temperature sensor (if used) are completely dry**; otherwise the relative humidity around the sensor will differ from the measured humidity inside the *FireStingO2*. It is recommended that the device and the sensor are **placed for >10 min. under constant environmental conditions** before the calibration is performed.

Ensure also that the correct sensor code has been entered in the **Settings** of the corresponding channel. If the sensor code displayed in **Factory 0% Calibration** is not correct, click on **Finish**,

go to the **Settings**, enter the correct **Sensor Code** and repeat the calibration.

Then the air temperature needs to be determined. Either a **Fixed Temperature** is adjusted manually or the temperature is read from the external temperature sensor by selecting **External Temperature Sensor**.

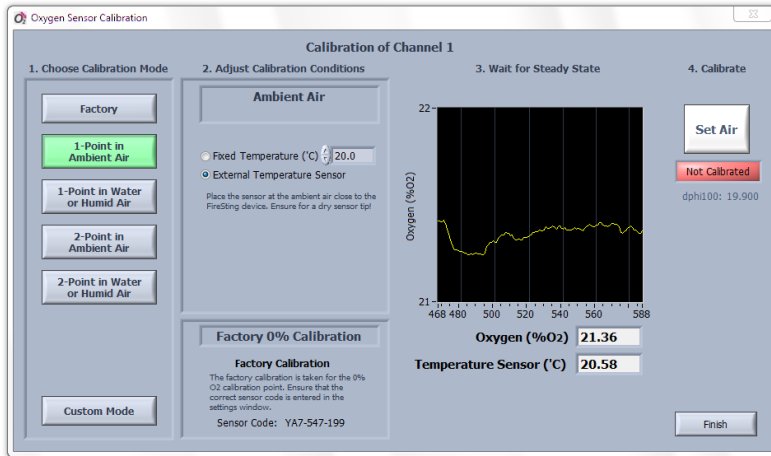

Wait now until the sensor reading is stable by observing the graph and the numerical display of the oxygen sensor reading. If **External Temperature Sensor** was selected, ensure also stable temperature readings indicated at **Temperature Sensor (°C)**. Note that the button **Set Air** will be highlighted as soon as the oxygen readings are within the expected range for the connected sensor type.

If all readings have reached their steady state, click on **Set Air**, and the actual oxygen sensor reading is taken for the air calibration. If the oxygen reading seems to be out of the expected range, a warning will be shown offering the possibility to repeat the calibration. A completed calibration is indicated by the green indicator **Calibrated at Air**.

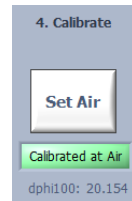

Finally, click on **Finish** for returning to the main window.

NOTE: If using retractable needle-type sensors (e.g. *OXR50*, *OXR230*, *OXR430*), it is important that the sensor tip is extended to position 2 or 3 (see chapter 5.1) when the calibration value is taken.

7.1.3 Calibration Mode: 1-Point in Water or Humid Air

NOTE: The calibration **1-Point in Water or Humid Air** is only possible if the **correct Sensor Code** has been entered in the **Settings** (see chapter 6.2).

The calibration mode **1-Point in Water or Humid Air** uses air saturated water or water-vapor saturated air for determining the air calibration value. The preparation of appropriate air calibration standards is explained in chapter 8. The 0% calibration value is taken from the **Sensor Code**.

Note, that this calibration mode will automatically read the atmospheric pressure from the internal pressure sensor in the *FireStingO₂*. The calibration standard with the air saturated water or water-vapor saturated air must be therefore exposed to the same atmospheric pressure (which is given in typical applications²).

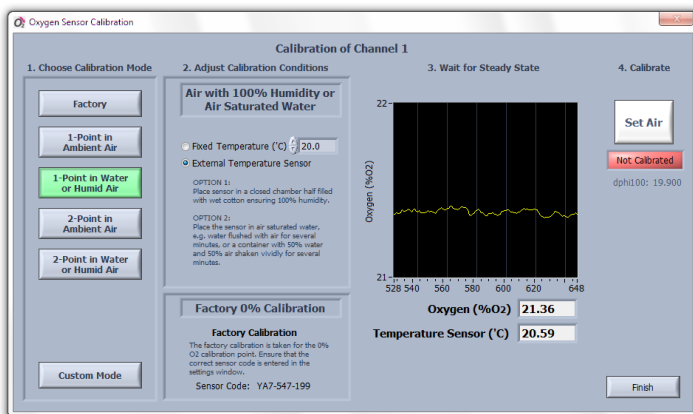

² In rare cases and for special applications the calibration standard might be exposed to different pressures than the ambient air where the *FireStingO₂* is positioned. In this case you have to choose the Custom Mode (chapter 7.1.6) where the calibration pressure can be entered manually.

Insert the oxygen sensor and the external temperature sensor (if used) into the flask containing the air-saturated water or water-vapor saturated air.

Ensure that the correct sensor code has been entered in the **Settings** of the corresponding channel. If the sensor code displayed in the **Factory 0% Calibration** is not correct, click on **Finish**, go to the **Settings**, enter the correct **Sensor Code** and repeat the calibration.

Then the temperature of the air-saturated water or water-vapor saturated air needs to be determined. Either, a **Fixed Temperature** is adjusted manually, or the temperature is read from the external temperature sensor by selecting **External Temperature Sensor**.

NOTE: Ensure constant calibration conditions! If the external temperature sensor is selected, ensure that the temperature sensor is placed close to the oxygen sensor.

Wait now until the oxygen sensor reading is stable by observing the graph. If **External Temperature Sensor** was selected, ensure also stable temperature readings indicated at **Temperature Sensor (°C)**. Note that the button **Set Air** will be highlighted as soon as the oxygen readings are within the expected range for the connected sensor type.

If all readings have reached their steady state, click on **Set Air**, and the actual oxygen sensor reading is taken for the air calibration. If the oxygen reading seems to be out of the expected range, a warning will be shown offering the possibility to repeat the calibration. A completed calibration is indicated by the green indicator **Calibrated at Air**.

Finally, click on **Finish** for returning to the main window.

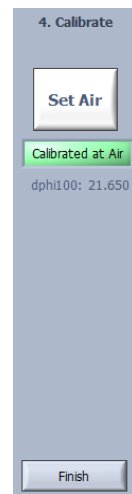

NOTE: If using retractable needle-type sensors (e.g. *OXR50*, *OXR230*, *OXR430*), it is important that the sensor tip is extended to position 2 or 3 (see chapter 5.1) when the calibration value is taken.

7.1.4 Calibration Mode: 2-Point in Ambient Air

NOTE: The calibration **2-Point in Ambient Air** is only possible if the **correct Sensor Code** has been entered in the **Settings** (see chapter 6.2).

In the calibration mode **2-Point in Ambient Air** both the air calibration value and the 0% calibration value are determined from a manual calibration. Ambient air is used for determining the air calibration value and a specially prepared 0% calibration standard for determining the 0% calibration value. The preparation of appropriate 0% calibration standards is explained in chapter 8.

Note, that this calibration mode will automatically read the atmospheric pressure and humidity from the internal pressure and humidity sensor in the *FireStingO2*. The temperature of the ambient air needs to be determined. Either, a **Fixed Temperature** is adjusted manually, or the temperature is read from the external temperature sensor by selecting **External Temperature Sensor**.

Oxygen Sensor Calibration

Calibration of Channel 1

1. Choose Calibration Mode

2. Adjust Calibration Conditions

3. Wait for Steady State

4. Calibrate

Factory

1-Point in Ambient Air

1-Point in Water or Humid Air

2-Point in Ambient Air

2-Point in Water or Humid Air

Custom Mode

Ambient Air

Fixed Temperature (°C) 20.0

External Temperature Sensor

Place the sensor at the ambient air close to the FireSting device. Ensure for a dry sensor tip!

0% Calibration

Fixed Temperature (°C) 20.0

External Temperature Sensor

Place the sensor in water mixed with sodium sulfate, or in water flushed with nitrogen gas for several minutes, or directly in nitrogen gas.

Oxygen (%O₂)

Oxygen (%O₂) 21.43

Temperature Sensor (°C) 20.16

Set Air

Not Calibrated

dph100: 19.900

Set 0%

Not Calibrated

dph0: 54.700

Finish

For the air calibration value (**Ambient Air**), place the oxygen sensor and the external temperature sensor (if used) **close to the air holes** at the backside of the *FireStingO2*.

Ensure that the **oxygen sensor and the external temperature sensor (if used) are completely dry**; otherwise the relative humidity around the sensor will differ from the measured humidity inside the *FireStingO2*. It is recommended that the device and the sensor are **placed for >10 min. under constant environmental conditions** before the calibration is performed.

Wait until the oxygen sensor reading is stable by observing the graph. If **External Temperature Sensor** was selected, ensure also stable temperature readings indicated at **Temperature Sensor (°C)**. Note that the button **Set Air** will be highlighted as soon as the oxygen readings are within the expected range for the connected sensor type.

If all readings have reached their steady state, click on **Set Air**, and the actual oxygen sensor reading is taken for the air calibration. If the oxygen reading seems to be out of the expected range, a warning will be shown offering the possibility to repeat the calibration. A completed calibration is indicated by the green indicator **Calibrated at Air**.

Subsequently, insert the oxygen sensor and the external temperature sensor (if used) into the 0% calibration standard.

Also for the 0% calibration standard either a **Fixed Temperature** is adjusted manually or the temperature is read from the external temperature sensor by selecting **External Temperature Sensor**.

Wait until the oxygen sensor reading is stable by observing the graph. If **External Temperature Sensor** was selected, ensure also stable temperature readings indicated at **Temperature Sensor (°C)**.

Note that the button **Set 0%** will be highlighted as soon as the oxygen readings are within the expected range for the connected sensor type.

If all readings have reached their steady state, click on **Set 0%**, and the actual oxygen sensor reading is taken for the 0% calibration. If the oxygen reading seems to be out of the expected range, a warning will be shown offering the possibility to repeat the calibration.

A completed calibration is indicated by the green indicator **Calibrated at 0%**.

Finally, click on **Finish** for returning to the main window.

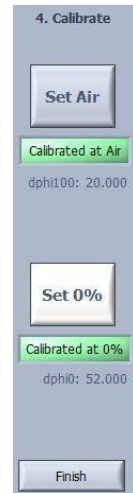

NOTE: If using retractable needle-type sensors (e.g. *OXR50*, *OXR230*, *OXR430*), it is important that the sensor tip is extended to position 2 or 3 (see chapter 5.1) when the calibration value is taken.

7.1.5 Calibration Mode: 2-Point in Water or Humid Air

NOTE: The calibration **2-Point in Water or Humid Air** is only possible if the **correct Sensor Code** has been entered in the **Settings** (see chapter 6.2).

In the calibration mode **2-Point in Water or Humid Air** both the air calibration value and the 0% calibration value are determined from a manual calibration. Air saturated water or water-vapor saturated air is used for determining the air calibration value and a specially prepared 0% calibration standard for determining the 0% calibration value. The preparation of appropriate calibration standards is explained in chapter 8.

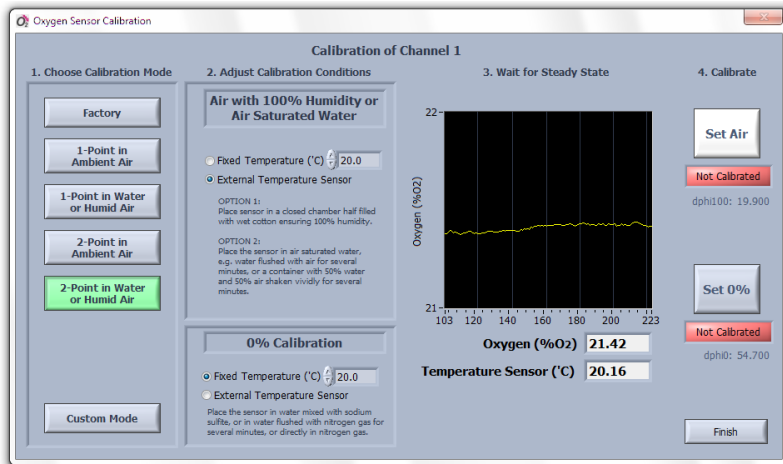

Note, that this calibration mode will automatically read the atmospheric pressure from the internal pressure sensor in the *FireStingO₂*. The calibration standards must be therefore exposed to the same atmospheric pressure (which is given in typical applications³).

For the air calibration point (**Air with 100% Humidity or Air Saturated Water**), place the oxygen sensor and the external temperature sensor (if used) into the flask, containing either water-vapor saturated air or air-saturated water (100% air saturation).

Then, the temperature of the air calibration standard needs to be determined. Either, a **Fixed Temperature** is adjusted manually, or the temperature is read from the external temperature sensor by selecting **External Temperature Sensor**.

Wait until the oxygen sensor reading is stable by observing the graph. If **External Temperature Sensor** was selected, ensure also stable temperature readings indicated at **Temperature Sensor**

³ In rare cases and for special applications the calibration standards might be exposed to different pressures than the ambient air where the *FireStingO₂* is positioned. In this case you have to choose the Custom Mode (chapter 7.1.6) where the calibration pressure can be entered manually.

(°C). Note that the button **Set Air** will be highlighted as soon as the oxygen readings are within the expected range for the connected sensor type.

If all readings have reached their steady state, click on **Set Air**, and the actual oxygen sensor reading is taken for the air calibration. If the oxygen reading seems to be out of the expected range, a warning will be shown offering the possibility to repeat the calibration. A completed calibration is indicated by the green indicator **Calibrated at Air**.

Subsequently, insert the oxygen sensor and the external temperature sensor (if used) into the 0% calibration standard.

Also for the 0% calibration standard either a **Fixed Temperature** is adjusted manually or the temperature is read from the external temperature sensor by selecting **External Temperature Sensor**.

Wait until the oxygen sensor reading is stable by observing the graph. If **External Temperature Sensor** was selected, ensure also stable temperature readings indicated at **Temperature Sensor** (°C). Note that the button **Set 0%** will be highlighted as soon as the oxygen readings are within the expected range for the connected sensor type.

If all readings have reached their steady state, click on **Set 0%**, and the actual oxygen sensor reading is taken for the 0% calibration. If the oxygen reading seems to be out of the expected range, a warning will be shown offering the possibility to repeat the calibration.

A completed calibration is indicated by the green indicator **Calibrated at 0%**.

Finally, click on **Finish** for returning to the main window.

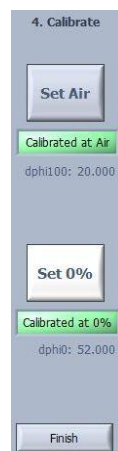

NOTE: If using retractable needle-type sensors (e.g. *OXR50*, *OXR230*, *OXR430*), it is important that the sensor tip is extended to position 2 or 3 (see chapter 5.1) when the calibration value is taken.

7.1.6 Calibration Mode: Custom Mode

The custom calibration mode is selected by clicking on the button **Custom Mode**. This mode allows the user to combine freely all possible calibration types for the air calibration and the 0% calibration. The air calibration type can be selected by clicking on the “Air Calibration Selector”. The 0% calibration type can be selected by clicking on the “0% Calibration Selector”.

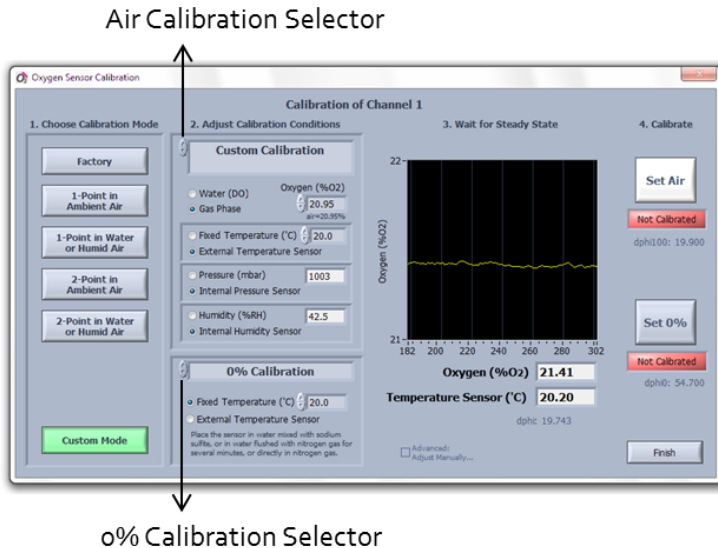

The following air calibration types can be chosen:

- **Factory Air Calibration** (refer to chapter 6)
- **Air with 100% Humidity or Air Saturated Water** (refer to chapter 7.1.3)
- **Ambient Air** (refer to chapter 7.1.2)
- **Custom Calibration** (more details below)

And for the 0% calibration the following types can be selected:

- **Factory 0% Calibration** (refer to chapter 6)
- **0% Calibration** (refer to chapter 7.1.4)

Most calibration types have been explained already in the preceding chapters (see references in the above list). Only the air calibration type **Custom Calibration** is a unique feature only available in the **Custom Mode**. The **Custom Calibration** offers the most flexible options for performing an air calibration as explained in the following.

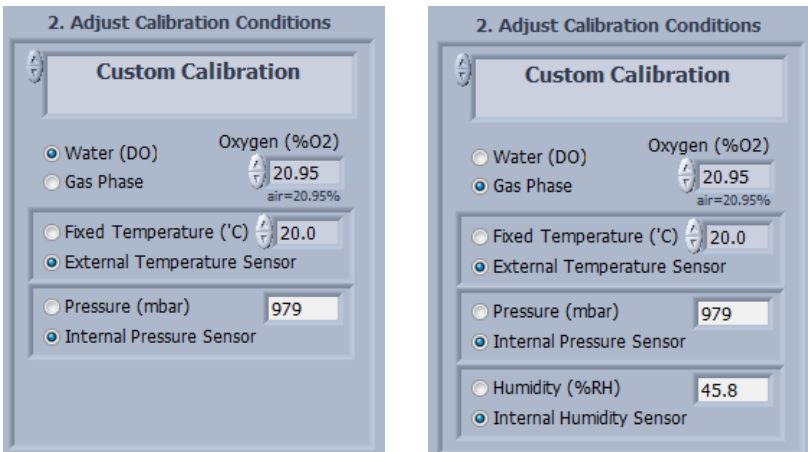

The oxygen level in the calibration standard can be freely chosen in **Oxygen (%O₂)**. If the air calibration standard is based on ambient air or air saturated water, then this value should be kept at 20.95%O₂, representing the standard oxygen volume fraction in ambient air. However, other values can be adjusted if custom calibration gases are used, of e.g. 5%O₂, which might be useful when using trace oxygen sensors.

Depending on the calibration standard used, select either **Water (DO)** for dissolved oxygen or **Gas Phase**. In the latter case the % of relative **Humidity (%RH)** of the gas needs to be determined with a hygrometer and entered. If the calibration is performed in the

same gas phase in which the *FireStingO2* is placed, the **Internal Humidity Sensor** of the *FireStingO2* can be selected. Using the internal humidity sensor requires several precautions; please refer to chapter 7.1.2 for more details.

For precision calibrations, it is generally advised to prepare calibration standards with 100%RH (refer to chapter 8), which eliminates any possible error source by the usage of the internal humidity sensor.

The actual **Pressure (mbar)** in the calibration standard can be entered manually in **Pressure (mbar)**. If the calibration standard is exposed to the ambient atmospheric pressure (which is given in most typical applications), the **Internal Pressure Sensor** can be selected alternatively. This option will read the ambient atmospheric pressure automatically from the integrated pressure sensor in the *FireStingO2*.

The temperature of the calibration standard needs to be determined. Either, a **Fixed Temperature** is adjusted manually, or the temperature is read from the external temperature sensor by selecting **External Temperature Sensor**.

Place now the oxygen sensor and the external temperature sensor (if used) into the calibration standard.

Wait until the oxygen sensor reading is stable by observing the graph. If **External Temperature Sensor** was selected, ensure also stable temperature readings indicated at **Temperature Sensor (°C)**.

If all readings have reached their steady state, click on **Set Air**, and the actual oxygen sensor reading is taken for the air calibration. A completed calibration is indicated by the green indicator **Calibrated at Air**.

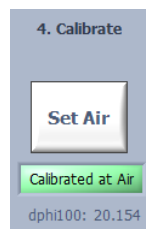

Consequently, the 0% calibration should be performed. If the calibration type **0% Factory Calibration** was selected no further steps are necessary (refer also to chapter 0).



If **0% calibration** was selected, follow the instructions given in chapter 7.1.4. Click on **Finish** for reverting to the main window.

NOTE: If using retractable needle-type sensors (e.g. *OXR50*, *OXR230*, *OXR430*), it is important that the sensor tip is extended to position 2 or 3 (see chapter 5.1) when the calibration value is taken.

7.2 Calibration with a 1.Generation *FireStingO2*

In case you are still working with a first generation *FireStingO2* (Firmware ≥ 2.3) the dialog window **FireSting Calibration** shows the Calibration Modes **Factory**, **1-Point**, **2-Point** and **Custom Mode**:

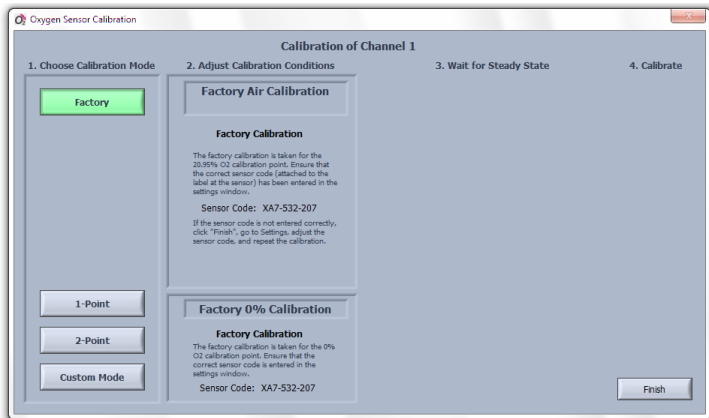

Three *main modes* of calibration can be chosen:

Factory calibration (for a quick, rough calibration): taking the 0% and the air calibration values from the sensor code; advised only for rough measurements.

1-Point: taking the 0% value from the sensor code and the air calibration value from a manual calibration for precise measurements around 21% O₂.

2-Point: taking the 0% and the air calibration value from a manual calibration for precise measurements over the full range (0-21% O₂ or 0-100% dissolved O₂ (DO)).

During the calibration of a sensor connected to a specific channel, the **Sample Interval** is automatically set to 0.5 s and the **Data Smoothing** to 5, ensuring a fast determination of a precise mean value during the sensor calibration. After finalization of the calibration, the program returns automatically to the former settings.

7.2.1 Calibration Mode: Factory (1. Generation *FireSting*)

NOTE: The **Factory Calibration** (only for rough measurements and testing purposes) is only possible if the **correct Sensor Code** has been entered in the **Settings** (see chapter 6.2).

If the calibration mode **Factory Calibration** is chosen, ensure that the correct sensor code has been entered in the **Settings** of the corresponding channel (as displayed in 2. **Adjust Calibration Conditions** of the **Oxygen Sensor Calibration** window). If the sensor code displayed is not correct, click on **Finish**, go to the **Settings**, enter the correct **Sensor Code** and repeat the **Factory Calibration**.

After clicking on **Finish** the factory calibration is completed, thereby returning to the main window of the corresponding channel.

7.2.2 Calibration Mode: 1-Point (1. Generation *FireSting*)

NOTE: The calibration mode **1-Point** is only possible if the **correct Sensor Code** has been entered in the **Settings** (see chapter 6.2).

The calibration mode 1-point is selected by clicking on the button **1-Point**. This mode uses a manual calibration in an air calibration standard for adjusting the air calibration value. The 0% calibration value is taken from the **Sensor Code**. The preparation of appropriate air calibration standards is described in chapter 8.1.

Depending on the air calibration standard used, select **Water (DO)** for dissolved oxygen or **Gas Phase**.

The air calibration standard (see also chapter 8.1) can be:

- ambient air of known humidity,
- water-vapor saturated air or
- air saturated water (100% air saturation).

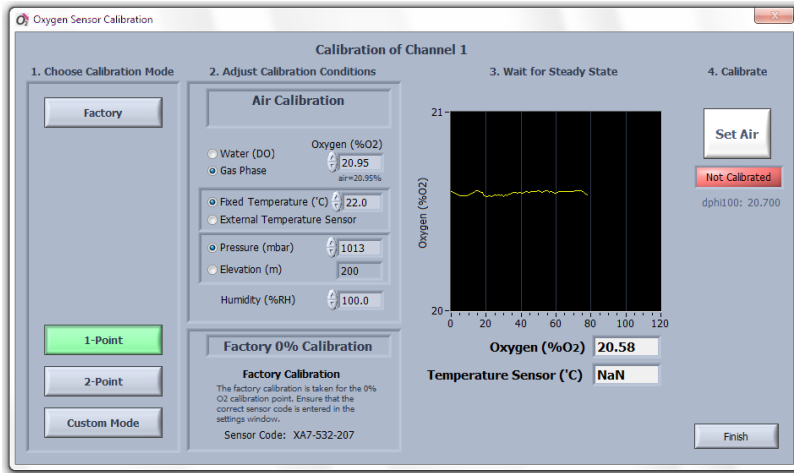

The oxygen level in the calibration standard can be freely chosen in **Oxygen (%O₂)**. If the air calibration standard is based on ambient air or air saturated water, then this value should be kept at 20.95%O₂ (default), representing the standard oxygen volume fraction in ambient air. However, other values can be adjusted if custom calibration gases are used, of e.g. 5%O₂, which might be useful when using trace oxygen sensors.

The temperature of the calibration standard needs to be adjusted. Either, a **Fixed Temperature** is adjusted manually, or the temperature is read from the external temperature sensor (placed close to the oxygen sensor) by selecting **External Temperature Sensor**.

Also the actual atmospheric pressure in the calibration standard can be entered manually in **Pressure (mbar)**. Normal conditions refer to 1013 mbar (default setting).

If the actual atmospheric pressure cannot be determined on site, it is alternatively possible to enter the actual **Elevation** in meters (m) **above sea level**. For this click on **Elevation** and enter the actual elevation. Please note, that this option takes only the elevation-dependent pressure change into account, but not the variations

due to the actual weather conditions. Therefore, determining the actual atmospheric pressure with a barometer gives more precise results.

The relative **Humidity (%RH)** of the gas phase (e.g. air) needs to be adjusted. If a calibration standard with water-vapor saturated air is used (see chapter 8.1.2), it must be adjusted to 100%RH. Otherwise, the humidity must be determined with a hygrometer and entered. If the current **Humidity** cannot be determined, a value of 40% is a good estimate (under normal conditions around 20°C, an incorrectly entered humidity will cause a max. calibration error of ca. 1% deviation).

Place now the oxygen sensor and the external temperature sensor (if used) into the air calibration standard.

NOTE: If using retractable needle-type sensors (e.g. *OXR50*, *OXR230*, *OXR430*), it is important that the sensor tip is extended to position 2 or 3 (see chapter 5.1) when the calibration value is taken.

Wait for steady state until the sensor reading is stable by observing the graph. If **External Temperature Sensor** was selected, ensure also stable temperature readings indicated at **Temperature Sensor (°C)**. Note that the button **Set Air** will be highlighted as soon as the oxygen readings are within the expected range for the connected sensor type (the latter does not apply for a custom air calibration with $\approx 20.95\% \text{O}_2$).

If all readings have reached their steady state, click on **Set Air**, and the actual oxygen sensor reading is taken for the air calibration. If the oxygen reading seems to be out of the expected range, a warning will be shown offering the possibility to repeat the calibration. A completed air calibration is indicated by the green indicator **Calibrated at Air**.



For the **Factory 0% Calibration**, no further steps are necessary (refer also to chapter 7.2.1). Ensure that the correct sensor code has been entered in the **Settings** of the corresponding channel.

7.2.3 Calibration Mode: 2-Point (1. Generation FireSting)

The calibration mode 2-point is selected by clicking on the button **2-Point**. In this mode both the air calibration value and the 0% calibration value are determined in specially prepared calibration standards. The preparation of appropriate 0% and air calibration standards is explained in chapter 8.

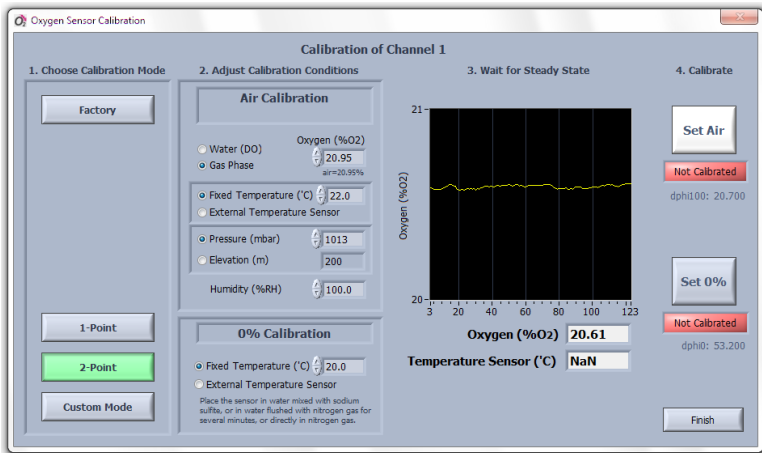

The air calibration standard and the calibration conditions need to be defined and entered as described for the **1-Point** calibration (see chapter 7.2.2).

Place now the oxygen sensor and the external temperature sensor (if used) into the air calibration standard.

NOTE: Ensure constant calibration conditions! If the external temperature sensor is selected, ensure that the temperature sensor is placed close to the oxygen sensor.

Wait for steady state until the sensor reading is stable by observing the graph. If **External Temperature Sensor** was selected, ensure also stable temperature readings indicated at **Temperature Sensor (°C)**. Note that the button **Set Air** will be highlighted as soon as the oxygen readings are within the expected range for the connected sensor type (the latter does not apply for a custom air calibration with $\neq 20.95\% \text{O}_2$).

If all readings have reached their steady state, click on **Set Air**, and the actual oxygen sensor reading is taken for the air calibration. If the oxygen reading seems to be out of the expected range, a warning will be shown offering the possibility to repeat the calibration. A completed air calibration is indicated by the green indicator **Calibrated at Air**.

NOTE: If using retractable needle-type sensors (e.g. *OXR50*, *OXR230*, *OXR430*), it is important that the sensor tip is extended to position 2 or 3 (see chapter 5.1) when the calibration value is taken.

Subsequently insert the oxygen sensor and the external temperature sensor (if used) into the 0% calibration standard. Wait for steady state until the sensor reading is stable by observing the graph. If **External Temperature Sensor** was selected, ensure also stable temperature readings indicated at **Temperature Sensor (°C)**. Note that the button **Set 0%** will be highlighted as soon as the oxygen readings are within the expected range for the connected sensor type.

If all readings have reached their steady state, click on **Set 0%**, and the actual oxygen sensor reading is taken for the 0% calibration. If the oxygen reading is out of the expected range, a warning will be shown offering the possibility to repeat the calibration. A completed 0% calibration is indicated by the green indicator **Calibrated at 0%**.

Finally, click on **Finish** for returning to the main window.

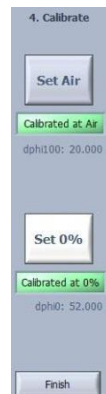

7.2.4 Calibration Mode: Custom (1. Generation FireSting)

The custom calibration mode is selected by clicking on the button **Custom Mode**. This mode allows the user to combine freely all possible calibration types for the air calibration and the o% calibration. The air calibration type can be selected by clicking on the “Air Calibration Selector”. The o% calibration type can be selected by clicking on the “o% Calibration Selector”.

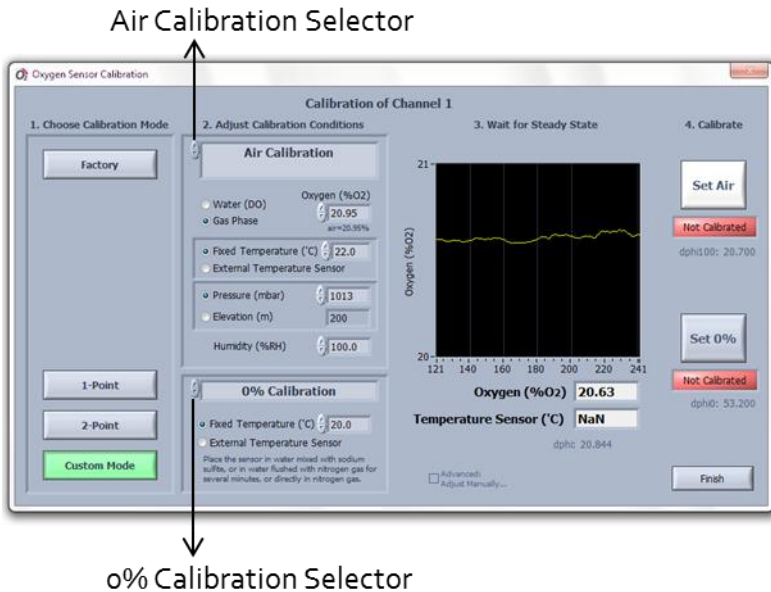

The following air calibration types can be selected:

- **Factory Air Calibration** (refer to chapter 7.2.1)
- **Air Calibration** (refer to chapter 7.2.2)

And for the o% calibration the following types can be selected:

- **Factory o% Calibration** (refer to chapter 7.2.1)
- **o% Calibration** (refer to chapter 7.2.3)

7.3 Advanced adjustments

This section is only for advanced users!

For very advanced applications it is possible to manipulate all internal calibration parameters of the *FireStingO2* manually. This option is accessible by selecting **Custom Mode** and subsequently clicking on **Advanced: Adjust Manually**, which opens a separate window showing all internal calibration parameters.

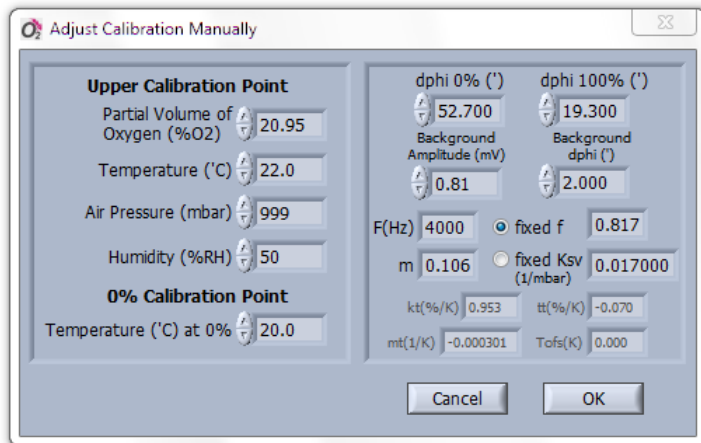

Here the **Upper Calibration Point** (default: **Partial Volume of Oxygen 20.95% O₂**) can be defined, as well as the calibration conditions (Temperature, Air Pressure, Humidity) as described for the **Custom Calibration** (see chapter 7.1.6). The **Temperature (°C)** needs also to be determined and entered for the **0% Calibration Point**.

Further, the phase shift "dphi" (**dphi**, see chapter 6.4 and 12.4) for the 0% calibration standard (**dphi 0%** in °) and for the 100% calibration standard (**dphi 100%** in °) can be adjusted manually.

The **Background Amplitude** (in mV) and the **Background dphi** (phase shift in °) can be adjusted (refer to chapter 9.2 for more details). These two values are only relevant, if a background

compensation for measurements with contactless sensors has been activated in the **Advanced Settings** of the respective channel.

The parameters **f**, **m**, **F**, **kt**, **mt**, **Tofs**, and **tt** are needed for the internal calculation of the oxygen concentration data. These parameters are specific constants for the *REDFLASH indicators*, and are automatically adjusted for the selected **Sensor Type** in the settings. *Unless otherwise communicated by PyroScience, it is strongly advised to leave these parameters at their default values.*

8 Calibration Standards

8.1 The Air Calibration Standard

The Air Calibration standard can be

- ambient air
- water-vapor saturated air
- air saturated water (100% air saturation)

When inserting fragile needle-type oxygen sensors into the calibration standards, ensure that the sensor tips are not hitting against e.g. the bottom of the flask or any hard object. Always use a proper lab stand for mounting the oxygen sensor!

All air calibration standards described in the following rely on the virtually constant oxygen content in the earth's atmosphere of about 20.95%O₂ in dry air. Slight deviations might be given in closed rooms occupied by many people (or e.g. candles, combustion engines) consuming the oxygen. So if in doubt, ensure a good ventilation of the room with fresh air e.g. by opening a window for some minutes.

Furthermore, the relative humidity of the air causes deviations from the ideal value of 20.95%O₂. Simply speaking, the water vapor in humid air replaces a fraction of the oxygen, resulting in a diminished oxygen level of e.g. 20.7%O₂. For temperatures around and below 20°C, this effect causes fortunately only a maximum deviation of about 0.5%O₂. However, for higher temperatures at 30°C or even 40-50°C, the humidity of the air gets a significant influence on the actual oxygen level. For example, ambient air at body temperature (37°C) with 100% relative humidity contains only 19.6%O₂ compared to dry air with 20.95%O₂.

During the calibration of oxygen sensors, there are two possibilities to take the humidity into account:

- (1) The relative humidity and the temperature of the ambient air must be determined during the calibration. The *Pyro Oxygen Logger* software calculates then automatically the real oxygen level under these conditions.
- (2) The calibration standard is prepared in a closed vessel either filled with water or partly filled with e.g. wet cotton wool or a wet sponge. This ensures a constant humidity of 100%RH and there is no need to measure the humidity.

Option (1) is utilized in the calibration standard "Ambient Air" (see section 8.1.1), whereby option (2) is utilized for the calibration standards "Water-Vapor Saturated Air" (see section 8.1.2) and "Air Saturated Water" (see section 8.1.3).

Another parameter even more important for the air calibration standard is the atmospheric pressure. The principle parameter measured by oxygen sensors is not the partial volume (i.e. "%O₂"), but the partial oxygen pressure (i.e. "mbar") (see also appendix 12.6). So an oxygen level of e.g. 20.7%O₂ (determined as described above by a given humidity and temperature) is converted internally by the *Pyro Oxygen Logger* software into a partial pressure of oxygen essentially by multiplying the relative oxygen level with the atmospheric pressure of e.g. 990 mbar (see chapter 12.6):

$$0.207 \times 990 \text{ mbar} = 205 \text{ mbar}$$

giving a partial oxygen pressure of e.g. 205 mbar. This is the essential calibration value used internally by the *Pyro Oxygen Logger* software. The atmospheric pressure can be influenced 1) by weather changes (e.g. varying between ca. 990 and 1030 at sea level) and 2) by the elevation above sea level (e.g. at 1000 m

elevation the typical atmospheric pressure is about 900 mbar compared to 1013 mbar at sea level).

Thus in summary, there are three important parameters to be known for the air calibration standard:

- Temperature (°C)
- Relative Humidity (%RH)
- Atmospheric Pressure (mbar)

The *FireSting* device and the *Pyro Oxygen Logger* software will guide the user through all calibration steps, not requiring the theoretical knowledge given above. And in case of a second generation *FireStingO2* (with micro USB connector), the built-in humidity and pressure sensors together with the internal or external temperature sensor will measure these parameters automatically for most calibration types (see also chapter 7).

8.1.1 Ambient Air

If ambient air is used as the air calibration standard, there is no need for preparation. The **dry** oxygen sensor, optionally together with the **dry** external temperature sensor, is simply exposed to the ambient air. Otherwise, follow the calibration procedures given in chapter 7.

For precise calibrations in ambient air, it is important that the measuring tips of the oxygen and the temperature sensor are **completely dry**. Wet sensor tips will cause undefined humidity levels around the sensor tips. And even worse, the evaporation of water drops would cool down the sensor tips causing undefined temperatures.

8.1.2 Water-Vapor Saturated Air

Enclose wet cotton wool into a flask (e.g. DURAN flask) with a lid prepared with holes for the oxygen sensor and a temperature sensor from *PyroScience*. Typically about $\frac{1}{3}$ to $\frac{1}{2}$ of the flask volume is filled with the wet cotton wool, while the other volume fraction is left free for inserting the tip of the oxygen sensor, and optionally also the temperature sensor. Otherwise, follow the calibration procedures given in chapter 7.

8.1.3 Air Saturated Water

Fill an appropriate amount of water into a flask (e.g. Duran flask) with a lid prepared with holes for inserting the oxygen sensor and a temperature sensor. Stream for about 10 minutes air through the water with an air stone connected to an air pump (available as commercial equipment for fish aquaria). Alternatively, if no air pump is available, fill water into the flask leaving $>50\%$ air in the head space, close it with a lid and shake the flask strongly for about 1 minute. Open the lid shortly for ventilating the headspace with fresh air. Close it again and shake the flask for 1 more minute. Insert the oxygen sensor, and optionally also the temperature sensor, into the flask and ensure that the tips of the sensors are immersed in the water. Otherwise, follow the calibration procedures given in chapter 7.

Please consider that streaming air through water may cause cooling of the water. Ensure a **correct temperature determination!**

8.2 The 0% Standard

The 0% calibration standard can be

- water mixed with a strong reductant
- water flushed with nitrogen gas (N₂)
- nitrogen gas (N₂)

8.2.1 Water Mixed with a Strong Reductant

Fill an appropriate amount of water into a glass flask (e.g. Duran flask) with a lid prepared with holes for inserting the oxygen sensor and a temperature sensor. Add a strong reductant, like sodium dithionite (Na₂S₂O₄) or sodium sulfite (Na₂SO₃) at a concentration of 30 g L⁻¹, creating oxygen-free water by chemical reaction. It is not recommended to use saline water (e.g. sea water) for this, because the high salinity of the water might prevent a proper dissolution of the reductant. Stir the solution until the salt is completely dissolved and let the solution stand for about 15 minutes. Insert the oxygen sensor and optionally also the temperature sensor into the flask, and ensure that the sensor tips are completely immersed into the water. Otherwise, follow the calibration procedures given in chapter 7.

Do not store the sensors in this solution and rinse them carefully after the calibration with demineralized water. Especially the retractable needle-type sensors (item no. *OXR50*, *OXR230*, *OXR430*) need to be rinsed very thoroughly, because salt crystallization within the needle might damage them irreversibly.

8.2.2 Water Flushed with Nitrogen Gas

Fill water into a glass flask (e.g. Duran flask) with a lid prepared with holes for inserting the oxygen sensor and a temperature sensor. Close it and stream for about 10 minutes nitrogen gas through the water. You might speed up this process by first boiling the water (and thereby removing all dissolved gases) and then stream the nitrogen gas during cooling through it. Insert the oxygen sensor, and optionally also the temperature sensor, into the flask, let it equilibrate and perform the calibration as described in chapter 7.

Please consider that streaming N₂ gas through water may cause cooling of the water. Ensure a **correct temperature determination** of the 0% calibration standard!

8.2.3 Nitrogen Gas

Flush 100% nitrogen gas through a glass flask (e.g. Duran flask) with a lid prepared with holes for inserting the oxygen sensor and a temperature sensor. Ensure that all air has been replaced by the nitrogen gas before performing the calibration. Insert the oxygen sensor, and optionally also the temperature sensor, into the flask, let it equilibrate and perform the calibration as described in chapter 7.

Ensure that no ambient air enters the flask again during the calibration process. Convective gas transport is a very fast process! It is therefore advised to keep flushing the flask with nitrogen gas during the complete calibration process!

Please consider that nitrogen gas from gas bottles might be significantly *cooled down* by the decompression process. Ensure a **correct temperature determination** of the calibration standard!

9 Calibration of Contactless Sensors

For preparing a setup with contactless oxygen sensors, please refer to the chapters 5.4-5.6.

9.1 Calibration Procedure

In general, the calibration procedure for contactless sensors (e.g. sensor spots, flow-through cells, respiration vials) is the same as for fiber-based oxygen sensors as described in the chapters 7 and 8. However, if a 1-point or a 2-point calibration should be performed, the calibration standards have to be filled directly into the vessel in which a sensor spot is glued into, into the tubing of the flow-through cell, or into the respiration vial.

If “Ambient Air” is used for the air calibration standard (see chapter 8.1.1), a good air circulation of the ambient air into the **dry** setup is important, ensuring that the relative humidity within the setup is identical to the relative humidity outside the setup (experienced by the *FireStingO2*). However, for typical applications around room temperature and below, a falsely determined relative humidity gives a maximum relative error of 1% for the air calibration (refer also to chapter 8.1). So, if this precision is sufficient, “Ambient Air” should be the preferred option for the air calibration standard.

For precision applications, where it is not possible to ensure a dry setup for the calibration procedure, the alternative air calibration standards “Water-Vapor Saturated Air” (see also chapter 8.1.2) or “Air Saturated Water” (see also chapter 8.1.3) should be preferred. In the first case some part of the inner volume of the setup can be filled with e.g. wet cotton wool ensuring 100%RH around the oxygen sensor position. In the latter case, the inner volume of the setup is simply filled with air saturated water prepared as described in chapter 8.1.3. Ensure that the oxygen sensor is **completely** covered with the air saturated water!

9.2 Manual Background Compensation

The calibration of contactless sensors (i.e. sensor spots, flow-through cells and respiration vials) includes a compensation of potential background fluorescence from the fiber-optic cable connecting the *FireStingO2* with the contactless oxygen sensor. Based on the **Fiber Length (m)** entered in the **Settings** (see chapters 6.2.1 and 6.2.2), a background signal for compensation is estimated automatically by the *Pyro Oxygen Logger* software. So the user usually does not notice the background compensation at all. For normal applications this should be the preferred procedure.

But for precision applications and especially for low signal intensities (e.g. <20mV), a manual background compensation can be alternatively performed by the user. For this, **Manual Background Compensation** must be selected in the **Advanced Settings** (see chapter 6.2.2). After opening the calibration window by clicking on **Calibrate**, a separate **Background Compensation** window will be opened automatically:

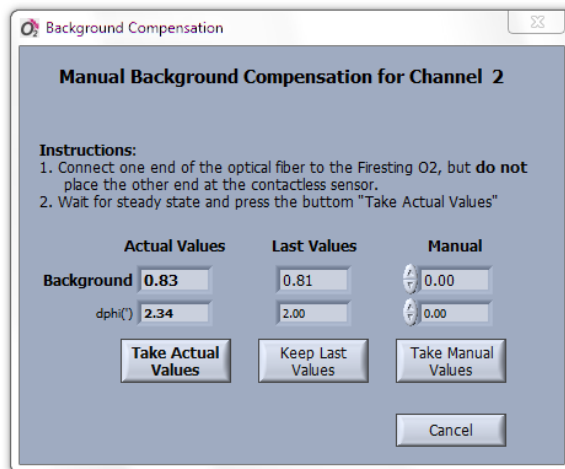

Here the background fluorescence of the connected *Optical Fiber* can be compensated. For this it is **important** that

- one end of the *Optical Fiber* is connected to the corresponding channel of the *FireStingO2* and
- the other end of the *Optical Fiber* is **not** attached to the sensor spot (i.e. disconnect this end from the spot adapter, adapter ring or from the flow-through cell)

Then wait for steady state and press the button **Take Actual Values**.

Alternatively, the button **Keep Last Values** can be used if the sensor spots are (re-)calibrated with the *same* optical fiber, which was background compensated before. Then the last values for the background compensation are kept.

It is also possible to enter values for the **Background** and **dphi** (°) manually into the field **Manual** and subsequently clicking on **Take Manual Values**. If you enter manually zero for **Background**, no background compensation is performed.

After the background compensation is finished, the window closes and the program proceeds with the main calibration window (see chapter 7). It is important that for the subsequent calibration process the *Optical Fiber* is again attached to the sensor spot position, e.g. by connecting this optical fiber end again to the spot adapter, adapter ring or to the flow-through cell.

Please ensure that *during the background compensation* the *Optical Fiber is not connected* to the contactless sensor.

Please ensure that *during the subsequent calibration process* the *Optical Fiber is again attached to* the contactless sensor.

Remind that the position of the spot adapter or adapter ring should not be changed after calibration of the sensor spot; otherwise it has to be re-calibrated.

10 Temperature Measurement

For the measuring range, precision and absolute accuracy of the internal and external temperature sensors refer to chapter 12.1.

10.1 Available External Temperature Sensors

The *FireStingO₂* provides one port for an external temperature sensor. *PyroScience* offers e.g. the dipping-probe temperature sensor *TDIP15* (with 1.5 mm tip diameter) and the submersible temperature sensors *TSUB21* (with 2.1 mm tip diameter, completely Teflon coated) and *TSUB36* (with 3.6 mm tip diameter, completely Teflon coated, shielded cable). The *TSUB21* and *TSUB36* are fully specified for long-term submersion into aquatic samples, i.e. the complete sensor including the cable can be submersed. In contrast, the *TDIP15* is only specified for long-term immersion of the 100 mm long probe tip into aquatic samples. However, the complete *TDIP15* including the cable is splash-proof and withstands easily short-term submersion into water.

10.2 Internal Temperature Sensor

It is not advised to use the internal temperature sensor for precision oxygen measurements.

The *FireStingO₂* meter has also a built-in internal temperature sensor for temperature measurements of the ambient air. If used during calibration or during temperature compensation of the oxygen readings in a gas sample or in air, ensure that the internal temperature in the *FireStingO₂* equals the ambient temperature in air or in the gas sample (a certain degree of warming by the instrument cannot be excluded!). It is advised to compare the Internal Temperature Sensor reading with an External Temperature Sensor connected to the *FireStingO₂* or with an external thermometer.

10.3 Automatic Temperature Compensation

The external temperature sensors can be simply used for recording the temperature in the measuring setup. However, the temperature sensor is especially useful in order to compensate automatically the oxygen sensor signals for temperature variations in the setup. The temperature compensation is needed due to two reasons:

- the luminescence of the *REDFLASH indicator* is temperature dependent and
- the conversion of some oxygen units needs to be compensated for the temperature.

In order to activate automatic temperature compensation for measurements in a water sample, the option **External Temperature Sensor** has to be selected in the **Conditions in the Samples** in the **Settings** of the respective channel. The temperature readings are also saved into the data file. For measurements in a gas sample, either the **External Temperature Sensor** or the **Internal Temperature Sensor** can be chosen. In the latter case, please ensure free circulation of the ambient air around the *FireStingO2* meter and exclude internal warming.

Please ensure that the oxygen and the temperature sensor are both inserted into the same experimental setup, if an automatic temperature compensation for the oxygen measurement is activated! Each *FireStingO2* provides only a single port for an external temperature sensor. For an automatic temperature compensation of >1 oxygen sensor, all oxygen sensors have to measure under identical temperature conditions or a temperature extension module with 4 temperature channels *TeX4* has to be coupled to the *FireStingO2*. Then the automatic temperature compensation is performed individually using the temperature sensor connected to the corresponding port of the *TeX4*.

However, it is also possible to use the automatic temperature compensation e.g. only for a single channel, whereas the other channels can be used for measurements at a **Fixed Temperature**. For the channels running at a fixed temperature, this temperature must be entered in the **Conditions in the Sample** in the **Settings**. It is on the users' authority to ensure that the sample is kept under this fixed temperature during the measurements.

Even if measurements with all activated oxygen sensors are performed under a **Fixed Temperature**, the external temperature sensor can be used for independent temperature measurements. This requires a separate **activation** of the external temperature sensor in the **Temperature** panel of the **Settings** (see chapter 6.2.4).

11 Analog Output and Auto-Mode

The standard operation mode of the *FireStingO2* is based on a PC running the *Pyro Oxygen Logger* software operating the *FireStingO2* via the USB interface (as described in this manual). This user-friendly operation mode is generally recommended, as it offers easy control over the full functionality of the *FireStingO2*. However, several advanced features are available in addition for integrating the *FireStingO2* in customized setups.

An integrated 4-channel **Analog Output** at the extension port can be used for transferring measurement results (e.g. oxygen concentration, temperature, pressure, humidity, signal intensity) as voltage signals to other electronic equipment (e.g. loggers, chart recorders, data acquisition systems).

Further, the *FireStingO2* can be operated in a so-called **Auto-Mode**, in which the *FireStingO2* performs measurements autonomously without any PC connected to it. The auto-mode *does not* possess any integrated logging functionality, but the measured values must be read out via the analog output e.g. by an external data logger.

And finally, the extension port offers also a complete digital interface (UART) for advanced integration possibilities into custom electronics equipment (see appendix 12.2). This UART interface might be also utilized during auto-mode operation for a digital read-out of the measured values.

11.1 Analog Output

The analog output is provided at the connector X2 of the extension port. It offers 4 channels with an output range of 0-2500 mV. The pin configuration is given in appendix 12.2. The analog output is always active and automatically updated each time the

FireStingO2 performs a new measurement (independent whether the *FireStingO2* is operated via a PC with the *Pyro Oxygen Logger* software, or if it is operated autonomously in the auto-mode).

The analog output can be configured by opening the **Settings** window and clicking there on the **Analog Output** button in the **Options** tab. A separate window will open.

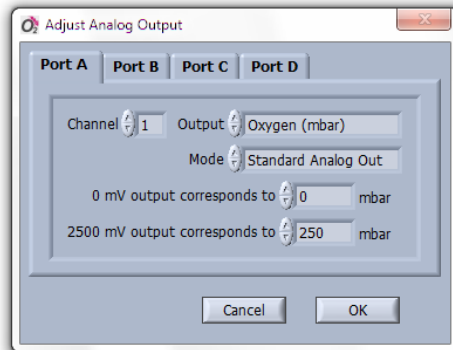

The settings of the 4 analog outputs can be adjusted in the respective tabs designated as **Port A-D**.

NOTE: The 4 analog outputs are deliberately designated with A, B, C, and D for distinguishing them clearly from the numbering 1, 2, 3, and 4 of the oxygen channels. The background is that the analog outputs are not fixed to specific oxygen channels ensuring highest flexibility.

Each analog output can be freely mapped to the oxygen **Channel** 1-4. The output parameter can be chosen with the selector **Output**. The following parameters can be selected: dphi (deg), Oxygen (μM), Oxygen (mbar), Oxygen (% air sat), Oxygen (%O₂), Signal Intensity (mV), Ambient Light (mV), External Temperature ($^{\circ}\text{C}$), Internal Temperature ($^{\circ}\text{C}$), Pressure (mbar), Humidity (%) or Analog In (mV). Note that the selected **Channel** number is only significant if an oxygen related parameter is selected (first 7 options in the **Output** selector).

The operation **Mode** of the analog output can be chosen as **Standard Analog Out** or as **Alarm if out of range**. The **Standard Analog Out** mode represents the standard mode resulting in

voltage signals proportional to the measured value. The linear scaling of the voltage signal can be freely adjusted at **0 mV output corresponds to** and **2500 mV output corresponds to**.

NOTE: Due to hardware restrictions, the very lower range of the analog output around 0-3 mV shows slight non-linearities. For precision measurements e.g. around 0% O₂ it is therefore recommended to map the zero oxygen level e.g. to 100 mV.

Example: **0 mV output corresponds to** -1 %O₂
 2500 mV output corresponds to 24 %O₂

This will give 100 mV for 0 % O₂, and 2200 mV for 21 %O₂.

The second operation mode of the analog output is **Alarm if out of range**. In this mode, the analog output can output only two possible voltages: either 0 mV or 2500 mV (so actually it is now a digital signal). The 0 mV are given if the measured parameter falls within a specific range, which can be freely adjusted at **lower alarm limit** and **upper alarm limit**. If the measured parameter gets out of this range, the analog output will switch to 2500 mV. This feature can be e.g. utilized for monitoring oxygen levels in a fish tank. If the oxygen levels might get dangerous for the fish, the 2500 mV of the alarm output could trigger some external electronic equipment which e.g. rings a bell.

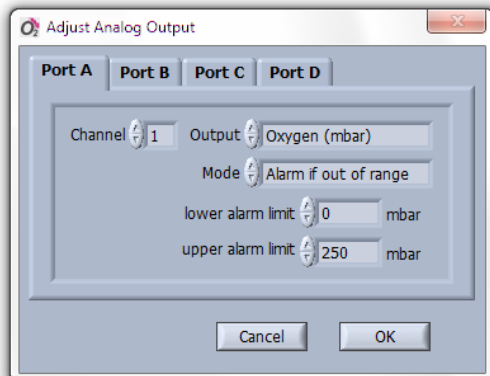

11.2 Auto-Mode

The auto-mode is simply activated (1) by connecting the USB port of the *FireStingO2* with a standard micro-USB-charger as used for many mobile phones or (2) by connecting two pins at the extension port (more details in appendix 12.2). So there is no connection to a PC anymore. The correct initiation of the auto-mode can be recognized by a significantly slower flashing frequency (ca. 4 flashes with a total duration of ca. 2-3 s) of the *FireSting* logo after power-up, compared to the faster flashing frequency when connecting it to a PC (see chapter 4). During auto-mode operation, the measurement results can be read out e.g. by an analog data logger from the analog output (see chapter 11.1).

NOTE: Some older micro-USB-charger do not fulfill the new common standard for micro-USB-chargers. Such an old micro-USB-charger might not be recognized by the *FireStingO2*, and thus the auto-mode is not started. This can be checked by observing the flashing frequency of the logo.

NOTE: Some micro-USB-charger have built in safety timers which shut down the power supply after e.g. 4 hours.

The basic idea behind the auto-mode is that all operations related to sensor settings and sensor calibrations are still performed during the normal operation with a PC. When this is done, the auto-mode can be configured by opening the **Settings** window and clicking there on the **Prepare Auto-Mode** button in the **Options** tab. A separate window will open.

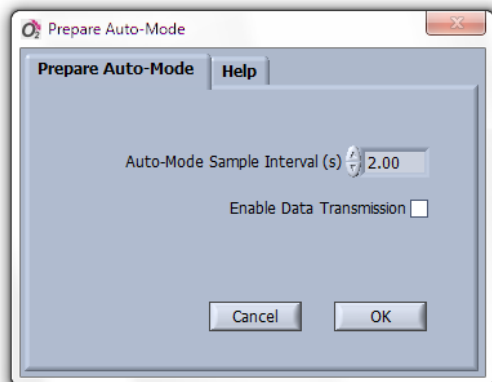

Here the **Auto-Mode Sample Interval (s)** can be adjusted, defining the time interval between consecutive measurements in the auto-mode. As an advanced feature, the option **Enable Data Transmission** activates digital data transmission via the UART interface of the extension port (details on request).

NOTE: Only sensors (e.g. oxygen channel 1-4, temperature, pressure, humidity) which are activated in the *Pyro Oxygen Logger* software will be also measured during the auto-mode. If e.g. the humidity sensor should measure during the auto-mode, the respective **Activate** button in the **Settings** window must be enabled.

11.3 Advanced Auto-Mode

NOTE: This section is only for advanced users!

For advanced applications, the auto-mode can be configured even more flexible as described in the preceding chapter. First, it is possible to define an independent sample interval for each oxygen channel; e.g. channel 1 is measured every 10 s, while channel 2 is measured only every 10 min. Second, optionally the measurements of each channel can be triggered externally by using the trigger input of the extension port (see appendix 12.2).

The advanced auto-mode can be configured by opening the **Settings** window and clicking there on the **Advanced Auto-Mode** button in the **Options** tab. A separate window will open.

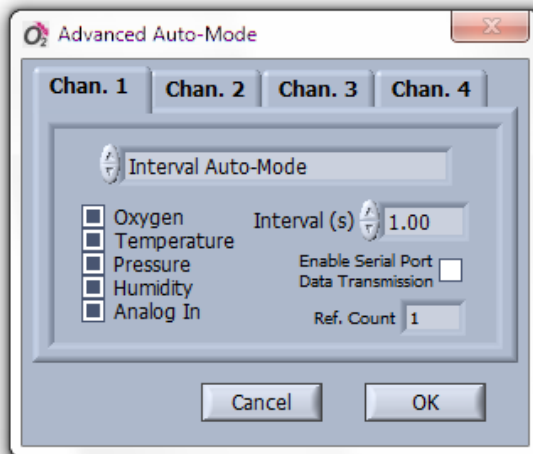

Three options can be selected. The first option **Disable Auto-Mode** disables any measurement in the auto-mode for the respective channel (but it does not disable the auto-mode in general!). For the second option **Interval Auto-Mode**, the sample **Interval (s)** can be adjusted for each channel independently. If the last option **Triggered Auto-Mode** is chosen, the measurement of the respective channel is only performed during the auto-mode if a

trigger signal was detected at the trigger input of the extension port (see appendix 12.2).

By checking **Enable Serial Port Data Transmission**, the results for the respective channel are additionally transmitted via the UART interface of the extension port. **Ref. Count** is an advanced feature only relevant for high speed applications (details on request).

IMPORTANT: Leave Ref. Count=1 for standard applications!

12 Appendix

12.1 Specifications of the *FireStingO2*

Dimensions	68 x 120 x 30 mm
Weight	350 g
Interface	USB 2.0
Power Supply	USB-powered (max 70mA at 5V)
Supported operating systems	Windows 2000, XP, VISTA, 7,8 (but not Windows RT)
Operating temperature	0 to 50°C
Max. relative humidity	Non-condensing conditions
Oxygen channels	1, 2, OR 4 (dependent on model)
Oxygen measuring principle	lifetime detection of REDFLASH indicator luminescence
Oxygen channel connector	fiber-optic ST-plug
Excitation wavelength	620 nm (orange-red)
Detection wavelength	760 nm (NIR)
Temperature channel	1 channel for 4-wire PT100
Max. sample rate	4 samples per second
Max. sample rate with enabled "high speed sampling" in Settings->Options	20 samples per second (ext. temperature sensor not activated)

External Temperature Sensors* Range, Resolution, Accuracy	-30°C to 150°C, 0.02°C, ±0.3°C
Internal Temperature Sensor* Range, Resolution, Accuracy	-40 to 125°C, 0.01°C, ±0.3°C
Internal Pressure Sensor Range, Resolution, Accuracy	300 to 1100 mbar, 0.06 mbar, typ. ±3 mbar
Internal Humidity Sensor Range, Resolution, Accuracy	0 to 100% rel. humidity (RH), 0.04% RH, typ. ±0.2% RH
Analog Input (1 channel) at extension port X1	0 to 2.5 VDC, 12 bit resolution Note: slight non-linearities around 0.5mV
Analog Output (4 channels) at extension port X2	0 to 2.5 VDC, 14 bit resolution Note: slight non-linearities around 0.5mV
Connector plug for extension port X1	Phoenix Contact item no. 1778887
Connector plug for extension port X2	Phoenix Contact item no. 1778861
Digital interface at extension port X1	UART with 3.3V levels (5V tolerant) 19200 baud, 8 data bit, 1 stop bit, no parity, no handshake

*Please note, that the oxygen sensors have a different temperature range (typ. 0-50°C specified, -20°C to 70°C not specified).

12.2 Extension Port X1

The extension port of the *FireStingO2* consists of the two connectors X1 and X2 (fitting connector plugs can be obtained from *Phoenix Contact* item no. 1778887 and 1778861).

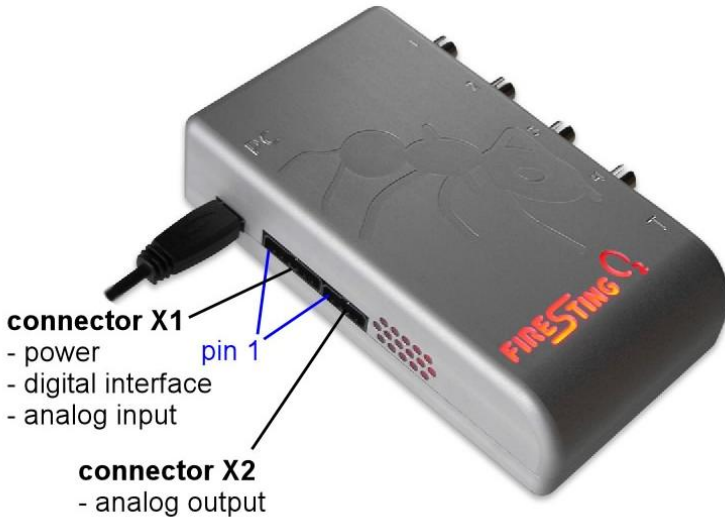

12.2.1 Connector X1 (Power, Digital Interface, Analog In)

The pin configuration of the connector X1 is given in the table below. Pins 1-2 (GND and VCC) can be used for providing an external power supply (3.5...5.0 VDC), if the *FireStingO2* should not be powered via the USB port. Pin 3 (/USB_DISABLE) should be tied to pin 1 (GND), if the *FireStingO2* should be operated in full-control mode (see below). The transmit and receive pins of the UART-interface are given at pins 4 (TXD) and 5 (RXD). If pin 6 (/AUTO) is tied to pin 1 (GND), then the auto-mode of the *FireStingO2* is activated (see chapter 11.2).

NOTE: While the auto-mode is activated by connecting pin 6 to pin 1, the USB interface and the receive pin of the UART interface are disabled. The *FireStingO2* will not respond to the *Pyro Oxygen Logger* software or any command sent to it via the UART interface!

Pin	Name	Function	Description
1	GND	Power	Ground
2	VCC	Power	Power supply, 3.5V to 5.0V DC max. 70 mA (typ 40 mA)
3	/USB_DISABLE	Disables USB interface	Ground
4	TXD	Digital Output (0V or 3.3V)	Data transmission pin of the UART interface
5	RXD	Digital Input (0V or 3.3V) (5V tolerant)	Data receive pin of the UART interface
6	/AUTO	Digital Input (0V or 3.3V, internally pulled-up to 3.3V)	Leave the /AUTO pin unconnected for normal operation. Connect to GND for auto-mode operation.
7	/TRIG_AIN	Digital Trigger Input or Analog Input (0...2.5VDC) If used as trigger input, a 10kOhm pull-up resistor must be connected between pin 7 and pin 2 (VCC.)	The trigger input is used for triggering a measurement in the "triggered auto-mode". The trigger is activated at the moment, when the pin is tied to GND. Alternatively this pin can be used to read in analog voltage signal.

Pin 7 (/TRIG_AIN) can be used for two alternative functions. Either it is used as a trigger input for triggering measurements in "triggered auto mode" (see chapter 11.3). In this case, the pin 7 must be permanently connected via a 10kOhm resistor ("pull-up resistor") to VCC at pin 2. The trigger is then activated by connecting pin 7 shortly to GND at pin 1 ("falling edge sensitive trigger").

Alternatively, pin 7 can be used as an analog input for reading in voltage signals (0..2.5 VDC), e.g. from an external sensor. If **Analog In** is activated in the **Settings** of the *Pyro Oxygen Logger* software,

then this voltage signal is logged along with the normal oxygen measurements (see chapter 6.2.5).

The following illustrations show typical use cases for the extension port X1:

USB-Powered Auto-Mode

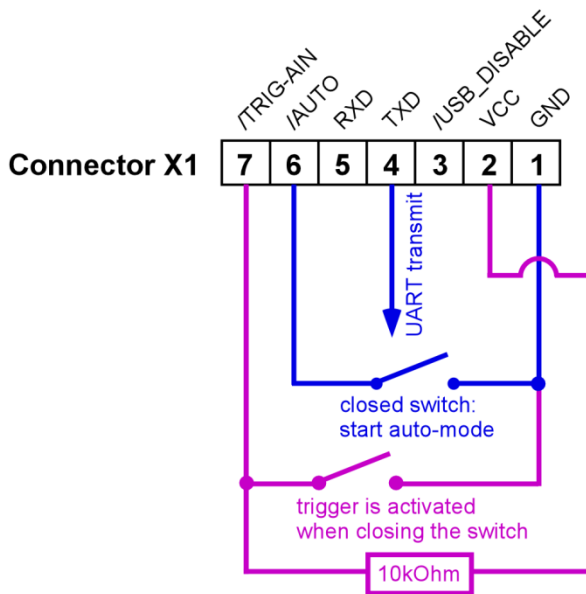

The *FireStingO2* is powered e.g. by a USB connection to a PC. By closing the blue switch between pin 6 and pin 1, the auto-mode is activated. Note, if the *FireStingO2* is powered by a micro-USB-charger, then the auto-mode is automatically activated (see chapter 11) and the blue switch has no function. If the advanced functionality “triggered auto-mode” should be utilized (see chapter 11.3), the pink circuit including a 10kOhm resistor has to be added. Closing the pink switch can then trigger the measurement in the auto-mode.

Auto-Mode with External Power Supply

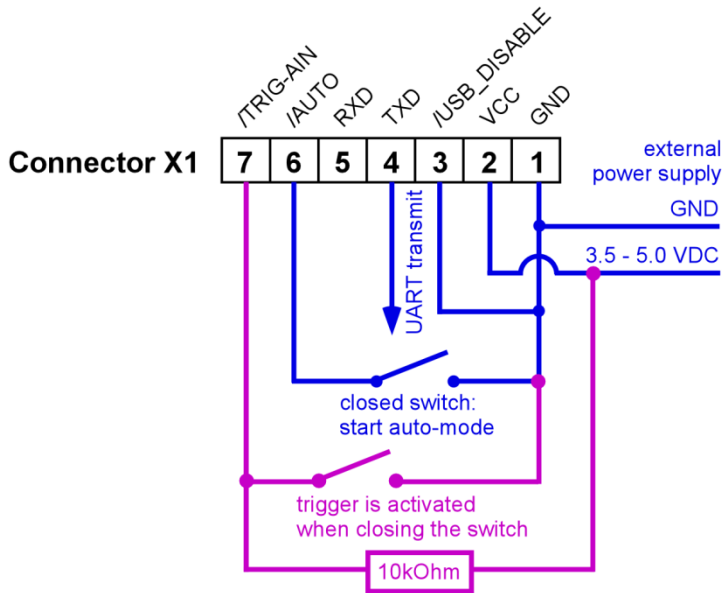

This configuration is almost identical to the preceding case, only the power supply is now given at pins 1 and 2. The USB connector of the *FireStingO2* is left unconnected. Note the additional connection between pin 1 and 3 powering down the internal USB interface of the *FireStingO2*.

Full Control Mode via the UART Interface

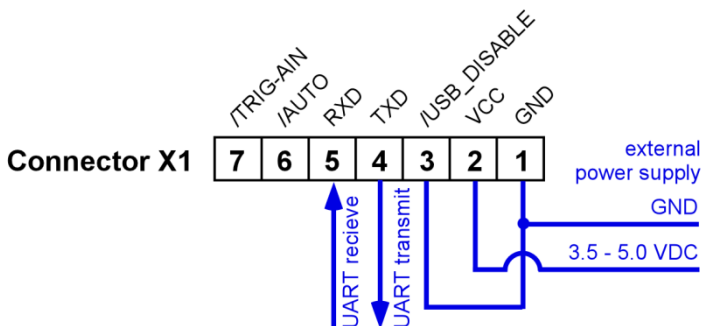

This configuration is used if the *FireStingO2* should be controlled completely via the UART interface by external custom electronic equipment (OEM applications). Note the additional connection between pin 1 and 3 powering down the internal USB interface of the *FireStingO2*. Otherwise unintended data communication via a potentially still connected PC might disrupt the UART communication. More information is available on request.

Connecting an external sensor voltage to the analog input:

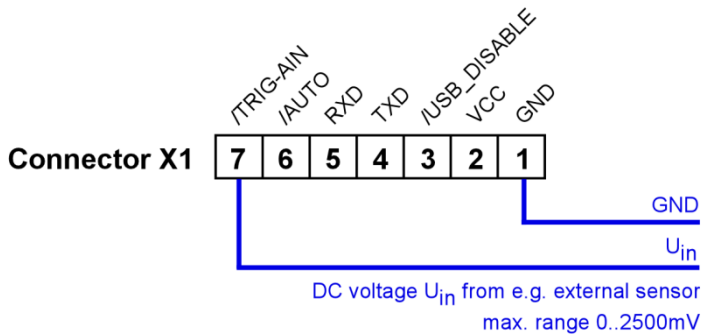

For reading in voltage signals between 0 and 2.5 VDC of e.g. an external sensor, simply connect the voltage to pin 1 and pin 7. Ensure a correct polarity. And ensure that the voltage does not exceed 2.5 VDC. Voltages above 3.3 VDC might damage the device.

12.2.2 Connector X2 (Analog Output)

The connector X2 provides 4 independent analog outputs with a range of 0-2.5V DC at a resolution of 14 bits (see table below). Refer to chapter 11.1 how to configure the analog outputs.

Pin	Name	Function	Description
1	GND		Ground
2	AO_A	Analog Output (0 – 2.5 V DC) (14 bit resolution)	Analog Output Port A (alternatively digital alarm output)
3	AO_B	Analog Output (0 – 2.5 V DC) (14 bit resolution)	Analog Output Port B (alternatively digital alarm output)
4	AO_C	Analog Output (0 – 2.5 V DC) (14 bit resolution)	Analog Output Port C (alternatively digital alarm output)
5	AO_D	Analog Output (0 – 2.5 V DC) (14 bit resolution)	Analog Output Port D (alternatively digital alarm output)

12.3 Troubleshooting

How to respond to the warnings shown in the *Pyro Oxygen Logger*:

Signal Too High

Too much ambient light exposed to the sensor, or amplification is too high, or LED intensity is too high:

- darken the surrounding
- and/or decrease **Amplification** in the **Advanced** settings
- and/or decrease **LED Intensity** in the **Advanced** settings

Low Signal

Sensor signal is too low:

- check whether the sensor cable is connected
- increase **Amplification** in the **Advanced** settings
- and/or increase **LED Intensity** in the **Advanced** settings
- replace sensor, the tip might be broken/bleached

Bad Reference

Internal problem of the electronics

- contact *PyroScience*

12.4 Measuring Principle

The new *REDFLASH technology* is based on the unique oxygen-sensitive *REDFLASH indicator* showing excellent brightness. The measuring principle is based on the quenching of the *REDFLASH indicator* luminescence caused by collision between oxygen molecules and the *REDFLASH indicator* immobilized on the sensor tip or surface. The *REDFLASH indicators* are excitable with red light (more precisely: orange-red at a wavelength of 610-630 nm) and show an oxygen-dependent luminescence in the near infrared (NIR, 760-790 nm).

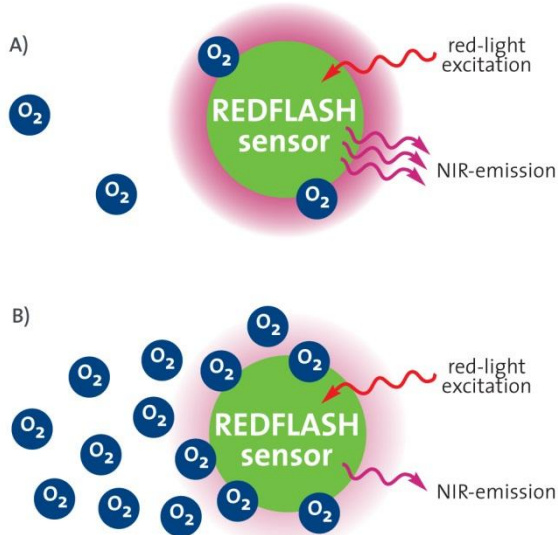

Principle: red light excited REDFLASH indicators show luminescence in the near infrared (NIR), which decreases with increasing oxygen (quenching effect).

A) high NIR emission at low oxygen and B) low NIR at high oxygen

The *REDFLASH technology* impresses by its high precision, high reliability, low power consumption, low cross-sensitivity, and fast response times. The red light excitation significantly reduces interferences caused by autofluorescence and reduces stress in biological systems. The *REDFLASH indicators* show much higher

luminescence brightness than competing products working with blue light excitation. Therefore, the duration of the red flash for a single oxygen measurement could be decreased from typically 100 ms to now typically 10 ms, significantly decreasing the light dose exposed to the measuring setup. Further, due to the excellent luminescence brightness of the *REDFLASH indicator*, the actual sensor matrix can be now prepared much thinner, leading to fast response times of the *PyroScience* oxygen sensors.

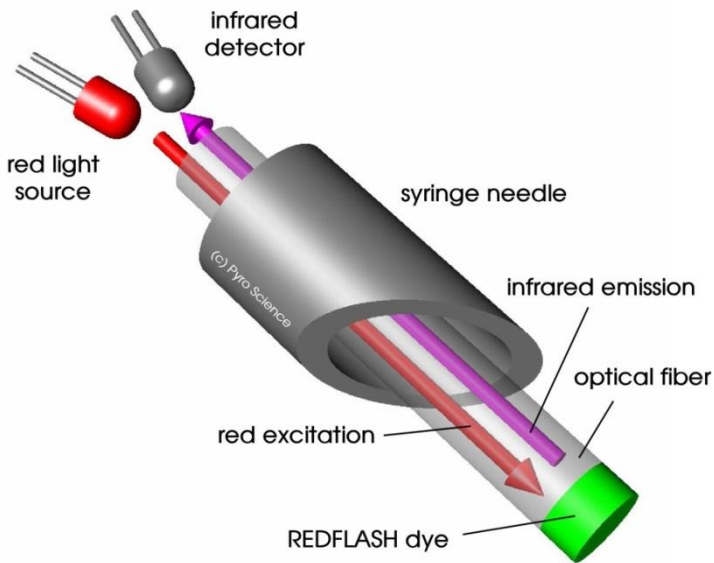

The measuring principle is based on a sinusoidally modulated red excitation light. This results in a phase-shifted sinusoidally modulated emission in the NIR. The *FireStingO₂* measures this phase shift (termed “dphi” in the software). The phase shift is then converted into oxygen units based on the Stern-Vollmer-Theory.

12.5 Operating several *FireStingO2* in parallel

The fiber-optic oxygen meter *FireStingO2* is available as 1-, 2-, or 4-channel version. However, in order to realize extendable multichannel systems with higher channel numbers (e.g. 8, 16, 32, or 64), several *FireStingO2* meters can be easily operated at a single PC as described in the following:

Connect each *FireStingO2* to a free USB port of your PC. If the PC does not provide a sufficient number of USB ports, you can use an external USB-hub. Ensure that the USB-hub provides sufficient power (each *FireStingO2* needs max. 70 mA); an external power supply for the USB-hub might be advisable.

The *Pyro Oxygen Logger* software has now to be started separately for each connected *FireStingO2*. So, if you want to operate e.g. 6 different *FireStingO2* meters, you have to start the *Pyro Oxygen Logger* software 6 times, which will open 6 *Pyro Oxygen Logger* windows on your desktop. The different windows operate completely independent from each other, and are associated to exactly one of the *FireStingO2* meters. In order to check which window is associated to a specific *FireStingO2*, simply press the **Flash Logo** button in the main window of the *Pyro Oxygen Logger* software, which induces a flashing of the red *FireSting* logo on the associated device for about 1 sec.

When closing the *Pyro Oxygen Logger* software, all settings and all current calibration data are saved in a "setup file", which is automatically loaded at the next startup. This setup file is saved specifically for each *FireStingO2* serial number, i.e. each *FireStingO2* in the above described setup keeps its own settings and calibration data.

12.6 Definition of Oxygen Units

phase shift

dphi

The phase shift *dphi* is the fundamental unit measured by the optoelectronics in the *FireStingO2* (see chapter 12.4). Please note, that *dphi* is not at all linearly dependent on the oxygen units, and **increasing** oxygen levels correspond to **decreasing** *dphi* values, and vice versa! As a thumb of rule, anoxic conditions will give about *dphi*=53, whereby ambient air will give about *dphi*=20.

raw value

raw value

Definition: *raw value* = %O₂ (uncalibrated)

The unit *raw value* is the default unit for uncalibrated sensors and shows only qualitative oxygen sensor readings.

partial pressure p_{O₂}

hPa = mbar

Used in: gas and water phase

For a calibrated sensor, the partial oxygen pressure p_{O₂} in units of *hPa* (equivalent to *mbar*) is the fundamental oxygen unit measured by the *FirestingO2*.

partial pressure p_{O₂}

Torr

Definition: $p_{O_2}[\text{Torr}] = p_{O_2}[\text{hPa}] \times 759.96 / 1013.25$

Used in: gas or water phase

volume percent p_v

%O₂

Definition: $p_v = p_{O_2}[\text{hPa}] / p_{\text{atm}} \times 100\%$

Used in: gas

with p_{atm} : actual barometric pressure

% air saturation A

% a.s.

Definition: $A[\%a.s.] = 100\% \times p_{O_2} / p_{100O_2}$

Used in: water phase

with $p_{100O_2} = 0.2095 (p_{atm} - p_{H_2O}(T))$
 $p_{H_2O}(T) = 6.112\text{mbar} \times \exp (17.62 T[^\circ\text{C}] / (243.12 + T[^\circ\text{C}]))$
 p_{O_2} : actual partial pressure
 p_{atm} : actual barometric pressure
 T : actual temperature
 $p_{H_2O}(T)$: saturated water vapor pressure at temperature T

Dissolved O₂ concentration C ***μmol/L***

Definition: $C [\mu\text{mol/L}] = A[\%a.s.] / 100\% \times C_{100}(T,P,S)$

Used in: water phase

with $C_{100}(T,P,S)$: interpolation formula for dissolved oxygen concentration in units of $\mu\text{mol/L}$ at temperature T , atmospheric pressure P and Salinity S (see chapter 12.7).

Dissolved O₂ concentration C ***mg/L = ppm***

Definition: $C [\text{mg/L}] = C [\mu\text{mol/L}] \times 32 / 1000$

Used in: water phase

Dissolved O₂ concentration C ***mL/L***

Definition: $C [\text{mL/L}] = C [\mu\text{mol/L}] \times 0.02241$

Used in: water phase

12.7 Table of Oxygen Solubility

The following Table shows the equilibrium oxygen concentration $C_{100}(T, P=1013\text{mbar}, S)$ in units of $\mu\text{mol}/\text{L}$ at standard atmospheric pressure of 1013 mbar as a function of water temperature in units of $^{\circ}\text{C}$ and salinity in units of PSU ("practical salinity unit" $\approx \text{g}/\text{L}$). In order to correct these values for the actual atmospheric pressure p_{atm} , the following formula has to be applied:

$$C_{100}(T, P, S) = C_{100}(T, P=1013\text{mbar}, S) \times p_{\text{atm}} / 1013\text{mbar}$$

References:

Garcia, HE and Gordon, LI (1992)

Oxygen solubility in seawater: Better fitting equations.

Limnol. Oceanogr. 37: 1307-1312

Millero, FJ and Poisson, A (1981)

International one-atmosphere equation of state of seawater.

Deep Sea Res. 28A: 625-629

Sal (PSU)	Temp 0	(°C) 5	10	15	20	25	30	35	40
0	456.6	398.9	352.6	314.9	283.9	257.9	235.9	217.0	200.4
2	450.4	393.6	348.1	311.1	280.6	255.0	233.3	214.7	198.3
4	444.2	388.5	343.7	307.3	277.3	252.1	230.8	212.4	196.3
6	438.1	383.3	339.4	303.6	274.0	249.3	228.3	210.2	194.3
8	432.1	378.3	335.1	299.9	270.8	246.5	225.8	207.9	192.3
10	426.1	373.3	330.8	296.2	267.6	243.7	223.3	205.7	190.3
12	420.3	368.4	326.7	292.6	264.5	240.9	220.9	203.6	188.4
14	414.5	363.5	322.5	289.1	261.4	238.2	218.5	201.4	186.5
16	408.8	358.7	318.4	285.5	258.3	235.5	216.1	199.3	184.6
18	403.2	354.0	314.4	282.1	255.3	232.8	213.7	197.2	182.7
20	397.7	349.3	310.4	278.6	252.3	230.2	211.4	195.1	180.8
22	392.2	344.7	306.5	275.2	249.3	227.6	209.1	193.0	179.0
24	386.8	340.2	302.6	271.9	246.4	225.0	206.8	191.0	177.1
26	381.5	335.7	298.7	268.5	243.5	222.5	204.5	189.0	175.3
28	376.2	331.2	294.9	265.3	240.6	219.9	202.3	187.0	173.5
30	371.0	326.9	291.2	262.0	237.8	217.4	200.1	185.0	171.7
32	365.9	322.5	287.5	258.8	235.0	215.0	197.9	183.0	170.0
34	360.9	318.3	283.9	255.7	232.2	212.5	195.7	181.1	168.2
36	355.9	314.1	280.3	252.5	229.5	210.1	193.6	179.2	166.5
38	351.0	309.9	276.7	249.5	226.8	207.7	191.4	177.3	164.8
40	346.2	305.8	273.2	246.4	224.1	205.4	189.3	175.4	163.1

12.8 Explanation of the Sensor Code

The oxygen sensors are delivered with an attached sensor code which can be entered in the Settings (refer to chapter 6.2). The following figure gives a short explanation about the information given in the sensor code.

Example Code: **XB7-532-205**

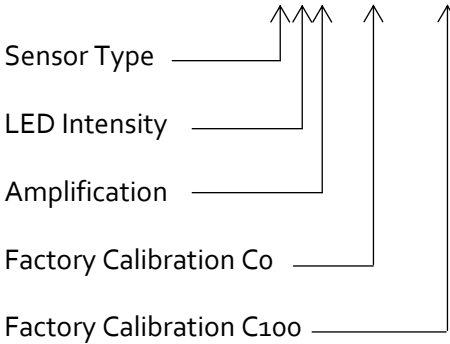

Sensor Type

- Z Oxygen Micro/Minisensor (normal range)
- Y Oxygen Minisensor (normal range)
- X Robust Oxygen Probe (normal range)
- W Oxygen Sensor Spot / FTC (normal range, fast)
- V Oxygen Minisensor (trace range)
- U Robust Oxygen Probe (trace range)
- T Oxygen Sensor Spot / FTC (trace range)
- S Oxygen Sensor Spot / FTC (normal range)
- Q Solvent-Resistant Oxygen Probe
- P Oxygen Nanoprobes

LED Intensity

A	10%	E	40%
B	15%	F	60%
C	20%	G	80%
D	30%	H	100%

Amplification

4	40X
5	80X
6	200X
7	400X

Co (Factory Calibration at 0%O₂)

$$dphi_0 = C_0 / 10$$

C₁₀₀ (Factory Calibration at 100%O₂)

$$dphi_{100} = C_{100} / 10$$

The values of the factory calibration are valid for the following calibration conditions:

Partial Volume of Oxygen (%O ₂)	20.95
Temperature at both calibration points (°C)	20.0
Air Pressure (mbar)	1013
Humidity (%RH)	0