

MH180 Leeb Hardness Tester

User's Manual

MITECH CO., LTD.



Mitech Inc. Ltd.

1 Overview	3
1.1 Advantages.....	3
1.2 Main Application & Testing Range	3
1.2.1 Main Application	3
1.2.2 Testing Range.....	3
1.3 Technical Specifications	4
1.4 Configuration	4
1.5 Working Conditions	5
2 Structure Feature & Testing Principle	5
2.1 Structure Feature	5
2.1.1 D Type Impact Device	6
2.1.2 Different Types of Impact Device.....	6
2.2 Main Screen	6
2.3 Keypad Definitions	7
2.4 Leeb Hardness Testing Principle.....	8
3 Preparation	8
3.1 Instrument Preparation and Inspection	8
3.2 Impact Device Selection	9
3.3 Preparation of the Sample Surface.....	9
4 Testing Program	10
4.1 Start-Up.....	10
4.2 Loading	10
4.3 Localization	10
4.4 Testing.....	10
4.5 Read Measured Value	11
4.6 Notification	11
5 Operation Detail	12
5.1 Power On/Off.....	12
5.2 Material Setting.....	12
5.3 Hardness/Strength testing	13
5.4 Impact Direction Setting.....	13
5.5 Average Times Setting	13
5.6 Data logging.....	13
5.6.1 Viewing stored file/Group.....	13
5.6.2 Clearing selected file/Group	14
5.7 Print Report.....	14
5.8 System Reset.....	14
5.9 EL Backlight	14
5.10 Auto Power Off.....	15
5.11 Battery Replacement.....	15
5.12 Connecting to a Computer	15
5.13 Error Code Reference	15
6 Maintenance & Servicing	16

6.1 Impact Device Maintenance	16
6.2 Instrument Maintenance Program.....	16
6.3 Fault Analysis & Evacuation	16
6.4 Notice of Transport and Storage Conditions.....	16
APPENDIX	17
Table 1	17
Table 2	18
Table 3	18
Table 4	19

MITECH CO., LTD.

1 Overview

1.1 Advantages

- Wide measuring range. Based on the principle of Leeb hardness testing theory. It can measure the Leeb hardness of all metallic materials.
- Large screen LCD, showing all functions and parameters. With EL background light.
- Seven impact devices are available for special application. Automatically identify the type of impact devices.
- Test at any angle, even upside down.
- Direct display of hardness scales HRB, HRC, HV, HB, HS, HL
- Large memory could store 100 groups (Relative to average times 32~1) information including single measured value, mean value, impact direction, impact times, material and hardness scale etc.
- Battery information showing the rest capacity of the battery.
- User calibration function.
- Software to connect to PC via RS232 port. Micro printer support.
- Compact plastic case, suitable for use under poor working conditions
- Continuous working period of no less than 100 hours with two alkaline batteries(AA size); Auto power off to save energy.
- Outline dimensions: 150×74×32 mm
- Weight: 245g

1.2 Main Application & Testing Range

1.2.1 Main Application

- Die cavity of molds
- Bearings and other parts
- Failure analysis of pressure vessel, steam generator and other equipment
- Heavy work piece
- The installed machinery and permanently assembled parts.
- Testing surface of a small hollow space
- Material identification in the warehouse of metallic materials
- Rapid testing in large range and multi-measuring areas for large-scale work piece

1.2.2 Testing Range

Testing range refer to Table 1 and Table 2 in the Appendix.

1.3 Technical Specifications

- Error and repeatability of displayed value see Table1-1 below.

Table 1-1

No.	Type of impact device	Hardness value of Leeb standard hardness block	Error of displayed value	Repeatability
1	D	760±30HLD 530±40HLD	±6 HLD ±10 HLD	6 HLD 10 HLD
2	DC	760±30HLDC 530±40HLDC	±6 HLDC ±10 HLDC	6 HLD 10 HLD
3	DL	878±30HLDL 736±40HLDL	±12 HLDL	12 HLDL
4	D+15	766±30HLD+15 544±40HLD+15	±12 HLD+15	12 HLD+15
5	G	590±40HLG 500±40HLG	±12 HLG	12 HLG
6	E	725±30HLE 508±40HLE	±12 HLE	12 HLE
7	C	822±30HLC 590±40HLC	±12 HLC	12 HLC

- Measuring range: HLD (170~960) HLD
- Measuring direction: 0~360°
- Hardness Scale: HL、HB、HRB、HRC、HRA、HV、HS
- Display: segment LCD
- Data memory: max. 100 groups (relative to impact times 32~1)
- Working power: 3V (2 AA size alkaline batteries)
- Continuous working period: about 100 hours (With backlight off)
- Communication interface: RS232

1.4 Configuration

Table 1-2

	No.	Item	Quantity	Remarks
Standard Configuration	1	Main unit	1	
	2	D type impact device	1	With cable
	3	Standard test block	1	
	4	Cleaning brush (I)	1	
	5	Small support ring	1	
	6	Alkaline battery	2	AA size
	7	Manual	1	
	8	Instrument package case	1	

	9			
Optional Configuration	11	Cleaning brush (II)	1	For use with G type impact device
	12	Other type of impact devices and support rings		Refer to Table 3 and Table 4 in the appendix.
	13	DataPro software	1	
	14	Communication cable	1	
	15	Micro Printer	1	
	16	Print cable	1	

1.5 Working Conditions

Working temperature: 0°C ~ +40°C;

Storage temperature: -30°C ~ +60°C

Relative humidity: ≤90%;

The surrounding environment should avoid of vibration, strong magnetic field, corrosive medium and heavy dust.

2 Structure Feature & Testing Principle

2.1 Structure Feature

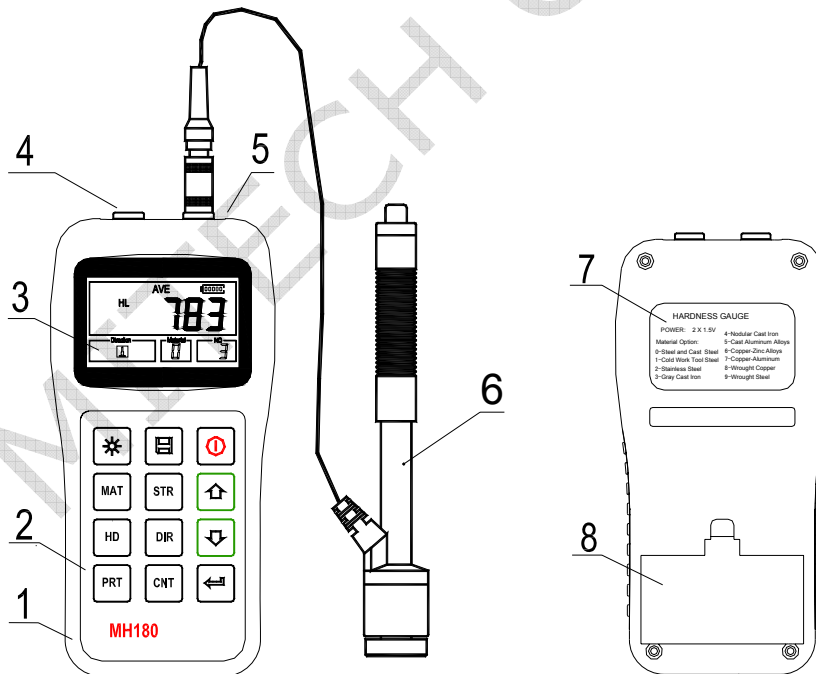

1. Main unit 2. Keypad 3. LCD display 4. Socket of RS232
5. Socket of impact device 6. Impact device 7. Label 8. Battery cover

2.1.1 D Type Impact Device

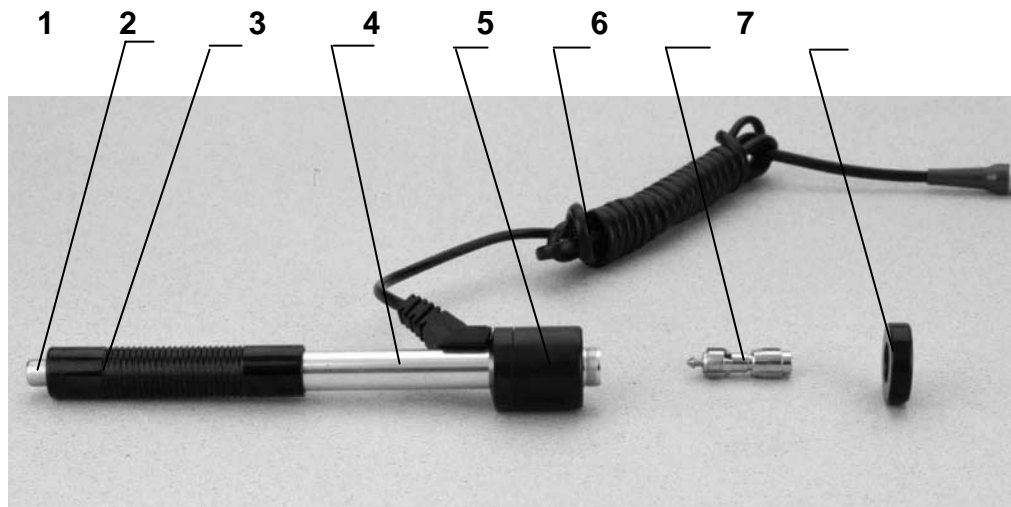

1 Release button 2 Loading tube 3 Guide tube 4 Coil unit
 5 Connection cable 6 Impact body 7 Supporting ring

2.1.2 Different Types of Impact Device

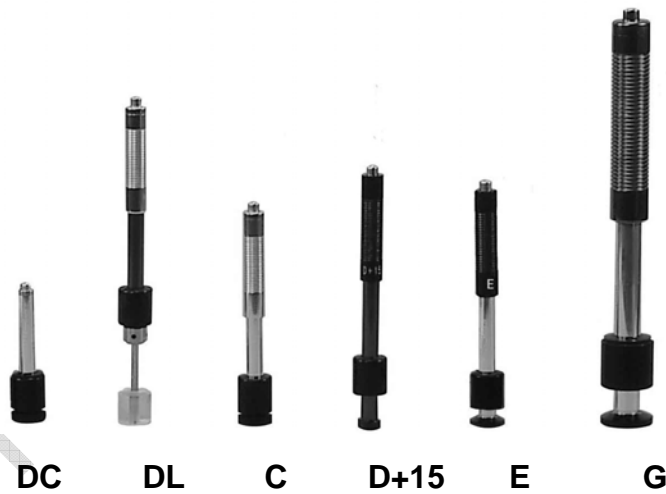

2.2 Main Screen

Below is the main display screen:

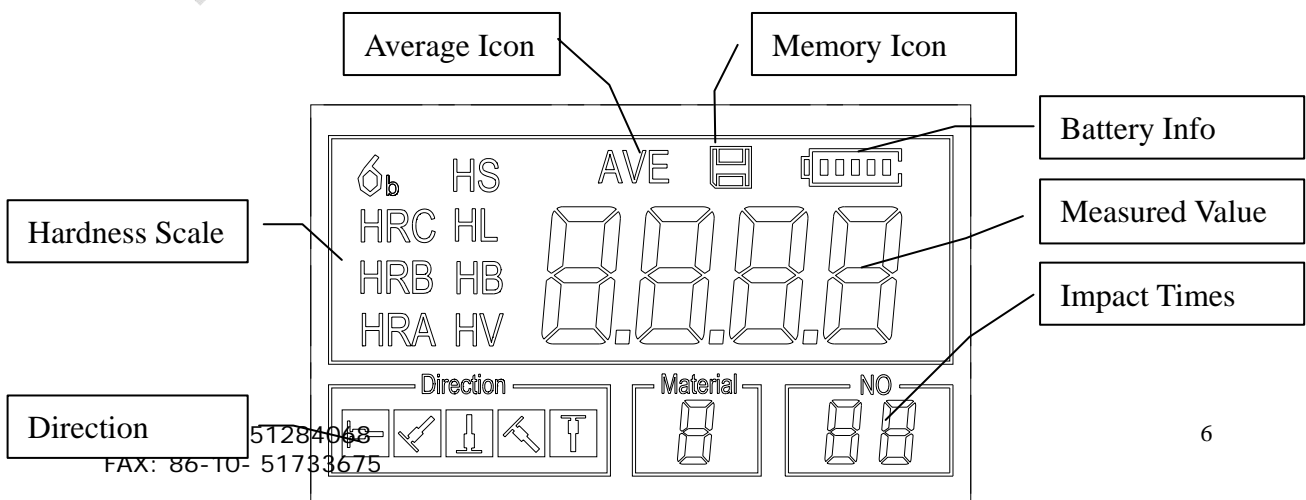

Material No

Instruction of the Main Display Screen:

Material: The present presetting material.

Impact direction: The present impact direction.

Hardness scale: Hardness scale of the present measured value.

Battery information: Showing the rest capacity of the battery.

Measured value: Display present single time measured value (without showing average icon), or display the present mean value (with average icon prompting). “-HI-” means over conversion value or measure range. “-LO-” means lower than conversion value or measure range.





Impact times: Times that have been impacted.













Average Icon: It will appear when showing the mean value of the measured values after reaching the presetting impact times.

Memory Icon: It appears when operating the instrument memory.

2.3 Keypad Definitions

Table 2-1

	/off the EL backlig		ave or Data Delete		e instrument on/off
	l Selection		ss/Strength switch		Up
	ss Scale Selection		n change		or Down
	ta		Times set		gging or Enter

- Press  key to store present group of measured value into memory. This operation is only valid after displaying the mean value.
- Press key  and  could display single measured value.
- Press  key could switch on of off the background light of LCD.
- Press  key to set the impact direction.
- Press  key to change the impact times in one group. The impact times item will flash when first pressing the  key, and then the impact times value will plus or minus when pressing the  or  key. Press  key finally to exit from changing the impact times process.
- Press  key to change the hardness scale.
- Press  key to change the material. Presetting hardness scale recovers to HL automatically after material presetting changed.

- Press key to switch between hardness test and strength test. Only D and DC type of impact device has the function of strength testing. So hardness testing is the only selection if the impact device is not D or DC type.
- Press key to print out the measured values after measurement.

2.4 Leeb Hardness Testing Principle

The basic principle is to use an impact body of certain weight impacts against the testing surface under certain test force, then measure the impacting velocity and the rebounding velocity of the impact body respectively when the spherically test tip is located 1mm above the testing surface.

The calculation formula is as follows:

$$HL=1000 \times VB / VA$$

Where, HL—— Leeb hardness value

VB—— Rebounding velocity of the impact body

VA—— Impacting velocity of the impact body

3 Preparation

3.1 Instrument Preparation and Inspection

Verification of the instrument is by using standard test block. The error and repeatability of displayed value should be within the regulation of Appendix table 2. The instrument and impact device must be calibrated using a standard hardness block before use as the first time, or having not been used for a long time, or having reset the instrument system.

Press key, meanwhile pressing down the key to power on the system. Then the user calibration screen shows as left below.

Test for 5 points on the standard hardness block. It would display the average measured value after measuring 5 times. Press key to change to its nominal value.

Press key to confirm the calibration finally. Or press the key to cancel the calibration.

Range of adjustment: $\pm 30HL$.

The measurement parameters, including the material setting, the hardness scale and the impact direction can't be changed during calibration.

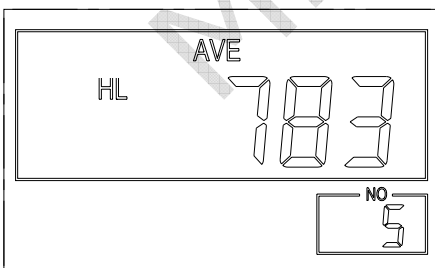

Note: Use a calibrated hardness tester, test the standard test block downward vertically for 5 times, the arithmetical average value compare with the value of standard test block. If this value exceeds the standard value, could use the function of user calibration to adjust.

3.2 Impact Device Selection

Refer to Appendix Table 1 and Table 3 for selection of impact device.

3.3 Preparation of the Sample Surface

Preparation for sample surface should conform to the relative requirement in Appendix Table 3.

- In the preparation processing for sample surface, the hardness effect of being heated or cold processing on the surface of sample should be avoided.
- Too big roughness of the being measured surface could cause error. So, the surface of the sample to be measured must appear metallic luster, smoothing and polish, without oil stain.
- Support of test sample. Support is no necessary for heavy sample. Medium-weight parts must be set on the smoothing and stable plane. The sample must set absolutely equability and without any wobble.
- Curved surface: The best testing surface of sample is flat. When the curvature radius R of the surface to be tested is smaller than 30mm (D, DC, D+15,C, E and DL type of impact device) and smaller than 50mm (G type of impact device), the small support ring or the shaped support rings should be chosen.
- The sample should have enough thickness, minimum thickness of sample should conform to Table 3.
- For the sample with hardened layer on surface, the depth of hardened layer should conform to Table 3.

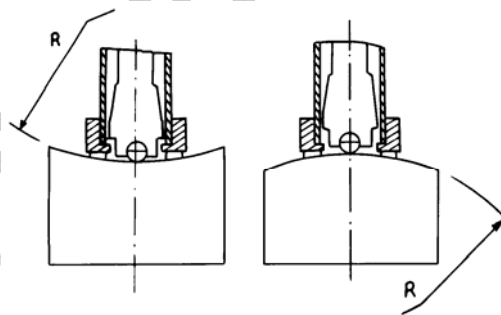

- Coupling. Light-weight sample must be firmly coupled with a heavy base plate. Both coupled surface must be flat and smooth, and there is no redundant coupling agent existing. The impact direction must be vertical to the coupled surface. When the sample is a big plate, long rod or bending piece, it can be deformed and become unstable, even though its weight and thickness is big enough, and accordingly, the test value may not be accurate. So the sample should be reinforced or supported at its back.
- Magnetism of the sample itself should be avoided.

4 Testing Program

4.1 Start-Up

- Insert the plug of the impact device into the socket of impact device on the instrument.
- Press the  key, now power is on. The instrument is in working mode.

4.2 Loading

Pushing the loading-tube downwards until contact is felt. Then allow it to slowly return to the starting position or using other method locking the impact body.

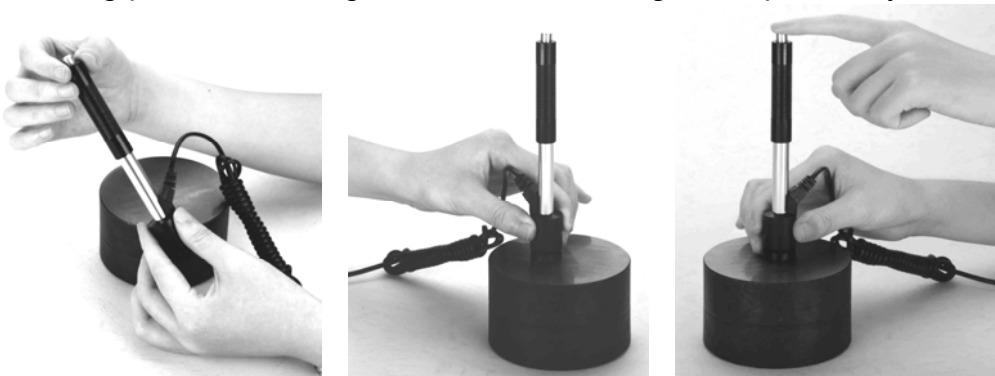

4.3 Localization

Press the impact device supporting ring firmly on the surface of the sample, the impact direction should be vertical to the testing surface.

4.4 Testing

- Press the release button on the upside of the impact device to test. The sample and the impact device as well as the operator are all required to be stable now. The action direction should pass the axis of the impact device.
- Each measure area of the sample usually need 3 to 5 times of testing operation. The result data dispersion should not more than mean value $\pm 15HL$.
- The distance between any two impact points or from the center of any impact point to the edge of testing sample should conform to the regulation of Table 4-1.
- If want accurate conversion from the Leeb hardness value to other hardness value, contrastive test is needed to get conversion relations for the special material. Use inspection qualified Leeb hardness tester and corresponding hardness tester to test at the same sample respectively. For each hardness value, each measure homogeneously 5 points of Leeb hardness value in the surrounding of more than three indentations which need conversion hardness, using Leeb hardness arithmetic average value and corresponding hardness average value as correlative value respectively, make individual hardness contrastive curve. Contrastive curve at least should include three group of correlative data.

Table 4-1

Type of Impact Device	Distance of center of the two indentations	Distance of center of the indentation to sample edge
	Not less than (mm)	Not less than (mm)
D、DC	3	5
DL	3	5
D+15	3	5
G	4	8
E	3	5
C	2	4

4.5 Read Measured Value

After each impact operation, the LCD will display the current measured value, impact times plus one, the buzzer would alert a long howl if the measured value is not within the valid range. When reaching the presetting impact times, the buzzer will alert a long howl. After 2 seconds, the buzzer will alert a short howl, and display the mean measured value.

4.6 Notification

- Replacing the impact device must be done during Power off. Otherwise the main body could not identify the type of the impact device, and it may damage the circuit board of the main body.
- You could not save the current test value if the impact time is less than the presetting times value.
- Only type D and type DC of impact device have the function of strength test option. You can not change the setting to strength testing when using other types of impact device. The setting would be set to hardness testing automatically after replacing the impact device whether the setting is hardness testing or not before.
- Not all materials could convert to all hardness scale value. The hardness scale is reset to HL automatically after changing the material. So select material firstly before changing the hardness scale.

5 Operation Detail

5.1 Power On/Off

Press  to power on the instrument. Be sure to plug in the impact device before powering on. The system would automatically detect the type of the impact device during power up, and would display this information on the screen. Users should pay attention to the probe type displayed on the screen. After pausing for several second, the screen will exit and enter the main display screen as following:

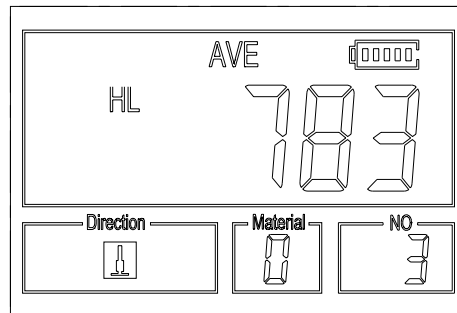

The instrument can be turned off by pressing the  key while it is working. The tool has a special memory that retains all of its settings even when the power is off.

5.2 Material Setting

Press  key to change the material to the one you want to preset. Hardness scale recovers to HL automatically after material presetting changed. Please select material firstly, then select hardness scale.

In hardness testing, you can select the material among the following materials: Steel and Cast Steel, Cold Work Tool Steel, Stainless Steel, Gray Cast Iron, Nodular Cast Iron, Cast Aluminium Alloys, Copper-Zinc Alloys, Copper-Aluminium Alloys, Wrought Copper and Wrought Steel. The relationship between the material number displayed on the instrument screen and the material is as follows:

Table 5-1

Material No.	Material	Material No.	Material
0	Steel and cast steel	5	Cast aluminium alloys
1	Cold work tool steel	6	Copper-Zinc alloys
2	Stainless steel	7	Copper –Aluminium alloys
3	Gray cast iron	8	Wrought copper
4	Nodular cast iron	9	Wrought steel

In strength testing, the following materials are selectable: Mild Steel, High-Carbon Steel, Cr Steel, Cr-V Steel, Cr-Ni Steel, Cr-Mo Steel, Cr-Ni-Mo Steel, Cr-Mn-Si Steel, Super Strength Steel and Stainless Steel. The relationship between the material number displayed on the instrument screen and the material is as follows:

Table 5-2

Material No	Material	Material No	Material
0	Mild steel	5	Cr-Mo steel

1	High carbon steel	6	Cr-Ni-Mo steel
2	Cr steel	7	Cr-Mn-Si steel
3	Cr-V steel	8	Super strength steel
4	Cr-Ni steel	9	Stainless steel

5.3 Hardness/Strength testing

Press **STR** key to switch between hardness testing and strength testing (6b) .

Note: Only D and DC type of impact device has the function of strength testing. So hardness testing is the only selection if the impact device is not D or DC type.

In hardness testing, Press **HD** key to change the hardness scale. The supported hardness scale includes: HL, HV, HB, HRC, HS, HRB and HRA.

Note:

- **Here only displays the valid hardness scale for the present selected impact device and material. It would not display the hardness scale which is not valid.**
- **Please select material firstly, then select hardness scale.**
- **Presetting hardness scale recovers to HL automatically after presetting material is changed.**

5.4 Impact Direction Setting

Press the **DIR** key to move to the impact direction that you will preset.

5.5 Average Times Setting

You could modify average times within the range of 1 to 32 as following:

- 1) Press **CNT** key in testing state. The impact times item will begin to flash;
- 2) Press **↑** or **↓** key to set the average times to the number you want.
- 3) Press **CNT** key finally to exit from the operation.





5.6 Data logging

At most one hundred files (F00-F99, one group as one file) can be stored inside the gauge. By simply pressing the **☐** key after a new measurement finishes-the screen showing the “AVE” icon, the measured hardness/strength group values will be saved to memory. The new saved file is appended as the last file of the memory. This function provides the user with the ability to view/delete a file/group previously saved in memory.

5.6.1 Viewing stored file/Group





To view the memory data, follow the steps:

- 1) Press the **☐** key to activate the data logging function. The memory icon will appear. It will display the current file name, the test parameter of the group data and the mean value of the group. If there is no data in the memory, it will display: <E04>, which means no memory data, and then return back.
- 2) Use the **↑** key and the **↓** key to select the desired file to view.

- 3) Press the  key to see details of that group data.
- 4) Use the  key and the  key to view each single measured data in that group while viewing details.
- 5) Press the  key to return to previous screen at any time during data logging.

5.6.2 Deleting selected file/Group

The user may require deleting a file from the instrument memory. The procedure is outlined in the following steps.





- 1) Press the  key to activate the data logging function. The memory icon will appear. It will display the current file name, the test parameter of the group data and the mean value of the group. If there is no data in the memory, it will display: <E04>, which means no memory data, and then return back.
- 2) Use the  key and the  key to scroll to the file that will be deleted.
- 3) Press the  key on the desired file. It will automatically delete the file, and display “-DEL”.
- 4) Press the  key, at any time, to exit the data logging function and return to measurement mode.

Note: *Do not shut down the instrument while deleting data. It could lead to unpredicted consequence if shutting down while deleting.*

5.7 Print Report

At the end of the inspection process, or end of the day, the user may require the readings be printed. This function is only available with the mini-printer.

Before printing, please insert one connection plug of the print cable (Optional parts) into the socket on the up-left of the main body, and insert the other plug into the communication socket of the mini-printer. You can print out the measurement result immediately after each testing process, by easily pressing the  key. If you want to print the data stored in the instrument memory, then following is the steps:

1. Press the  key to activate the data logging function. The memory icon will appear.
2. Use the  key and the  key to select the desired file.
3. Press the  key to print the selected file. This operation will send all the data in current file to the mini printer via RS232 port and print them out.
4. Press the  key to exit the data logging functions and return to measurement mode.

5.8 System Reset

Press down the  key while powering on the instrument will restore factory defaults. The only time this might possibly helpful is if the parameter in the gauge was somehow corrupted.

5.9 EL Backlight

With the EL background light, it is convenient to work in the dark condition. Press key  to switch on or switch off the background light at any moment as you need after power on.



Since the EL light will consume much power, turn on it only when necessary.

5.10 Auto Power Off

The instrument features an auto power off function designed to conserve battery life. If the tool is idle (neither measuring nor any key operation) for 5 minutes, it will turn itself off. Before powering off, the LCD display of the instrument will continue flashing for 20 seconds. Except key , press any key could stop the twinkle of LCD screen and stop the operation of power off at the moment.

While the voltage of the battery is too low, the display will show <E00>, then power off automatically.

5.11 Battery Replacement

Two AA size alkaline batteries are needed as the power source. After several hours' usage of the batteries, the battery symbol on the screen will be shown as . The more of dark part indicates the more close to fill. When the battery capacity runs out, the battery symbol will be shown as  and will begin to flash. When this occurs, the batteries should be replaced by a new pair.

Pay attention to the polarity of the batteries!

Please take out the batteries when not working during a long period of time.

5.12 Connecting to a Computer

The Instrument is equipped with a RS232 serial port. Using the accessory cable (The cable and following referred software are optional parts), the gauge has the ability to connect to a computer, or external storage device. Measurement data stored in the memory of the gauge can be transferred to the computer through the RS232 port. Detailed information of the communication software and its usage refer to the software manual.

5.13 Error Code Reference

Error Code	Explanation	Error Code	Explanation
E00	Battery exhausted	E05	Can not print
E01	Value out of range	E06	
E02	Measurement not finished	E07	
E03	Data already saved	E08	
E04	No memory data	E09	

6 Maintenance & Servicing

6.1 Impact Device Maintenance

- After the impact device has been used for 1000--2000 times, please use the nylon brush provided to clean the guide tube and impact body. When cleaning the guide tube, unscrew the support ring first, then take out the impact body, spiral the nylon brush in counter-clock direction into the bottom of guide tube and take it out for 5 times, and then install the impact body and support ring again.
- Release the impact body after use.
- Any lubricant is absolutely prohibited inside the impact device.

6.2 Instrument Maintenance Program

- When using standard Rockwell hardness block to testing, if all the error is bigger than 2 HRC, it may be the invalidation of impacted ball top caused by abrasion. Changing the spherical test tip or impact object should be considered.
- When the hardness tester appears some other abnormal phenomena, please do not dismantle or adjust any fixedly assembled parts. Fill in and present the warranty card to us. The warranty service can be carried on.

6.3 Fault Analysis & Evacuation

Fault Appearance	Fault Analysis	Handling method
Failure power on	Battery exhaustion	Replace the batteries
No measured value	mpact device cable failure	Replace the cable

6.4 Notice of Transport and Storage Conditions

- Keep it away from vibration, strong magnetic field, corrosive medium, dumpiness and dust. Storage in ordinary temperature.
- With original packing, transport is allowed on the third grade highway.

APPENDIX

Table 1

Material	Method	Impact device					
		D/DC	D+15	C	G	E	DL
Steel and cast steel	HRC	20~ 68.5	19.3~ 67.9	20.0~ 69.5		22.4~70.7	20.6~ 68.2
	HRB	38.4~ 99.6			47.7~ 99.9		37.0~ 99.9
	HRA	59.1~ 85.8				61.7~88.0	
	HB	127~ 651	80~638	80~683	90~646	83~663	81~646
	HV	83~976	80~937	80~996		84~1042	80~950
	HS	32.2~ 99.5	33.3~ 99.3	31.8~ 102.1		35.8~ 102.6	30.6~ 96.8
Cold work tool steel	HRC	20.4~ 67.1	19.8~ 68.2	20.7~ 68.2		22.6~70.2	
	HV	80~898	80~935	100~ 941		82~1009	
Stainless steel	HRB	46.5~ 101.7					
	HB	85~655					
	HV	85~802					
Grey cast iron	HRC						
	HB	93~334			92~326		
	HV						
Nodular cast iron	HRC						
	HB	131~ 387			127~ 364		
	HV						
Cast aluminium alloys	HB	19~164		23~210	32~168		
	HRB	23.8~ 84.6		22.7~ 85.0	23.8~ 85.5		
BRASS(copper-zinc alloys)	HB	40~173					
	HRB	13.5~ 95.3					
BRONZE(copper-aluminium/tin alloys)	HB	60~290					
Wrought copper alloys	HB	45~315					

Table 2



No.	Material	HLD	Strength σ_b (MPa)
1	Mild steel	350~522	374~780
2	High-Carbon steel	500~710	737~1670
3	Cr steel	500~730	707~1829
4	Cr-V steel	500~750	704~1980
5	Cr-Ni steel	500~750	763~2007
6	Cr-Mo steel	500~738	721~1875
7	Cr-Ni-Mo steel	540~738	844~1933
8	Cr-Mn-Si steel	500~750	755~1993
9	Super strength steel	630~800	1180~2652
10	Stainless steel	500~710	703~1676

Table 3

Type of impact device	DC(D)/DL	D+15	C	G	E
Impacting energy	11mJ	11mJ	2.7mJ	90mJ	11mJ
Mass of impact body	5.5g/7.2g	7.8g	3.0g	20.0g	5.5g
Test tip hardness: Dia. Test tip: Material of test tip:	1600HV 3mm Tungsten carbide	1600HV 3mm Tungsten carbide	1600HV 3mm Tungsten carbide	1600HV 5mm Tungsten carbide	5000HV 3mm synthetic diamond
Impact device diameter: Impact device length: Impact device weight:	20mm 86(147)/ 75mm 50g	20mm 162mm 80g	20mm 141mm 75g	30mm 254mm 250g	20mm 155mm 80g
Max. hardness of sample	940HV	940HV	1000HV	650HB	1200HV
Mean roughness value of sample surface Ra:	1.6 μ m	1.6 μ m	0.4 μ m	6.3 μ m	1.6 μ m
Min. weight of sample: Measure directly Need support firmly Need coupling tightly	>5kg 2~5kg 0.05~ 2kg	>5kg 2~5kg 0.05~2kg	>1.5kg 0.5~1.5kg 0.02~0.5kg	>15kg 5~15kg 0.5~5kg	>5kg 2~5kg 0.05~2kg
Min. thickness of sample Coupling tightly Min. layer thickness for	5mm	5mm	1mm	10mm	5mm

surface hardening		≥0.8mm	≥0.8mm	≥0.2mm	≥1.2mm	≥0.8mm
Size of tip indentation						
Hardness 300HV	Indentation diameter Depth of indentation	0.54mm 24 μ m	0.54mm 24 μ m	0.38mm 12 μ m	1.03mm 53 μ m	0.54mm 24 μ m
Hardness 600HV	Indentation diameter Depth of indentation 压痕深度	0.54mm 17 μ m	0.54mm 17 μ m	0.32mm 8 μ m	0.90mm 41 μ m	0.54mm 17 μ m
Hardness 800HV	Indentation diameter Depth of indentation	0.35mm 10 μ m	0.35mm 10 μ m	0.35mm 7 μ m	-- --	0.35mm 10 μ m
Available type of impact device		DC: Test hole or hollow cylindrical; DL: Test slender narrow groove or hole	D+15: Test groove or reentrant surface	C: Test small, light, thin parts and surface of hardened layer	G: Test large, thick, heavy and rough surface steel	E: Test super high hardness material

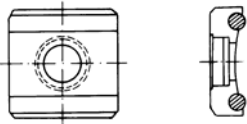
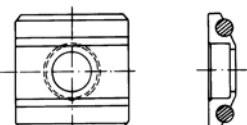
Table 4

No.	Type	Sketch of non-conventional Supporting ring	Remarks
1	Z10-15		For testing cylindrical outside surface R10~R15
2	Z14.5-30		For testing cylindrical outside surface R14.5~R30
3	Z25-50		For testing cylindrical outside surface R25~R50
4	HZ11-13		For testing cylindrical inside surface R11~R13
5	HZ12.5-17		For testing cylindrical inside surface R12.5~R17
6	HZ16.5-30		For testing cylindrical inside surface R16.5~R30
7	K10-15		For testing spherical outside surface SR10~SR15

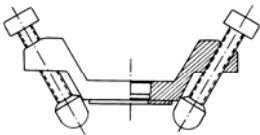
8	K14.5-30		For testing spherical outside surface SR14.5~SR30
9	HK11-13		For testing spherical inside surface SR11~SR13
10	HK12.5-17		For testing spherical inside surface SR12.5~SR17
11	HK16.5-30		For testing spherical inside surface SR16.5~SR30
12	UN		For testing cylindrical outside surface, radius adjustable R10~∞

Mitech Inc. Ltd.

**Address: Room 1405, Yi Hai Plaza, 16# of Tsinghua East Road,
Haidian District, Beijing, China**

Tel: 86-10-51733679

Fax: 86-10-51733675

Pc : 100083

Web: www.mitech-ndt.com