

Cable Strippers: High, Low and Medium Voltage



It is extremely important to use the right tool for each job - this will avoid risks, save time and ensure the proper finish. The following pages contain a wide range of cable stripping tools.

LOW VOLTAGE CABLE STRIPPERS

We can supply a wide range of tools for preparing low voltage cables for insulated overhead lines, underground networks, industrial cables, etc.

TL5749 DCBTP tool

The DCBTP tool quickly and easily strips low voltage cables of two different sizes (per tool), between 16 and 150 mm², with two different stripping lengths, 51,5 and 66,5 mm



- Length 155 mm.
- Weight 160 g.

NOTE

For enquiries and orders, please quote the section and strip length required.

TL2969 DCSBTP tool

The star-shaped DCSBTP tool quickly and easily strips low voltage cables. Six sections can be stripped with one tool (between 16 and 150 mm).



- Length 130 mm.
- Weight 200 g.

TL3077 PRBT2020 wire-stripping pliers

The PRBT2020 pliers strip the exterior sheath of LV cables, increasing safety in hot-line work (insulated to 1000v).

EN 60900 Capacity 50 - 240 mm

- Length 275 mm.
- Weight 650 g.



TL3076 PG1 wire-stripping pliers

PG wire-stripping pliers strip the sheath from low voltage cables, both single and three core, without needing to adjust the cutting blades. Thanks to their unique design, it is impossible for the operator to be injured since all the cutting areas are protected.

REFERENCE	MODEL	CAPACITY (mm)
TL3076	PG1	8 a 21
TL3082	PG2	21 a 35



Longitudinal cut

Circular cut

Strip



NOTE

Blades are available for different depths of cut.



MEDIUM VOLTAGE CABLE STRIPPERS

This section includes a variety of tools for preparing medium voltage cables. These tools are suitable for all kinds of synthetic insulation materials, with peelable and non-peelable semiconductors and for cables insulated with impregnated paper.

INDIVIDUAL TOOLS

TL3083

PG3 Pliers

PG3 wire-stripping pliers strip the sheath from medium voltage cables, both single and three core, without needing to adjust the cutting blades. Thanks to their unique design, it is impossible for the operator to be injured since all the cutting areas are protected.



Longitudinal cut



Circular cut



Strip



NOTE

Blades are available for different depths of cut.

TL3018

Tool for peelable semiconductors

For separating the semi-conductive tape from M.V. cables without damaging the insulation, quickly, cleanly and with no danger to the operator.

REFERENCE	MODEL	CAPACITY (mm)	WEIGHT(gr)
TL3018	LHM1R	14 a 40	630
TL3019	LHM2R	38 a 60	900



PARTS BLADE

REFERENCE	DIAMETER (mm)
TL3046	14 a 40
TL3047	38 a 60



MEDIUM VOLTAGE CABLE STRIPPERS

TL2994

Tool for non-peelable semiconductors

For separating non-peelable semi-conductive tape from M.V. cables manufactured using triple extrusion; the tape is vulcanised to the primary insulation, making it extremely difficult to remove using traditional techniques.

REFERENCE	MODEL	CAPACITY (mm)	WEIGHT (gr)
TL2994	ASC25R1	14 a 40	650
TL2995	ASC25R2	38 a 60	850



PARTS BLADE	
REFERENCE	CAPACITY (mm)
TL3041	14 a 40
TL3042	38 a 60



TL2998

Tool for primary insulation

For removing primary insulation from medium voltage RVH and DVH cables without damaging the conductor. The BRMRD1E tool regulates the length of cut in the insulation.

REFERENCE	MODEL	CAPACITY (mm)	WEIGHT (gr)
TL2998	BRMRD1E	14 a 40	1,100
TL3008	LH2	38 a 60	2,010



PARTS BLADE	
REFERENCE	CAPACITY (mm)
TL3024	14 a 40
TL3004	38 a 60





MEDIUM VOLTAGE CABLE STRIPPERS

TL3049

Tool for creating cones on primary insulation

This tool is for forming the conical 'pencil point' on M.V. cables. It is available for all voltages and 2 sections of up to 240 mm². It is important to note that one tool is used for each section and voltage. Weight 470 g approx depending on model.

SECTION	REF. 12/20	REF. 18/30
25	TL3049	TL3050
35	TL3051	TL3052
50	TL3053	TL3055
70	TL3056	TL3057
95	TL3058	TL3059
120	TL3060	TL3061
150	TL3062	TL3063
185	TL3064	TL3065
240	TL3066	TL3067



NOTE
Reference **TL3068**:
replacement blade.



ACCESSORIES

TL5819

Separator tool

After using the peelable semiconductor tool, this tool enables the semiconductor to be removed easily by hand.

- Dimensions: 108 x 35 x 35 mm.
- Weight 130 g.



Separate the peelable semiconductor



Remove the peelable semiconductor



TL2974

Separator tool

Tool for removing the layer of lead from the conductor.



TL3001

GRI scraper

The GRI scraper, made of stainless steel, removes any non-peelable semiconductor residue stuck to the cable insulation.

- Dimensions: 250 x 40 x 25 mm.
- Weight 190 g.



MEDIUM VOLTAGE CABLE STRIPPERS

INDIVIDUAL TOOL KITS



TL3078

ALTL1235 Stripping kit

Impact resistant PVC case, equipped with the following items:

- TL3083 pliers for stripping sheaths.
- TL3018 tool for stripping peelable semiconductor.
- TL2998 tool for removing primary insulation.
- PVC carrying case.

TL3079

ALTL1236 Stripping kit

Impact resistant PVC case, equipped with the following items:

- TL3083 pliers for stripping sheaths.
- TL2994 tool for stripping non-peelable semiconductor.
- TL2998 tool for removing primary insulation.
- PVC carrying case.



TL3080

ALTL1237 Stripping kit

Impact resistant PVC case, equipped with the following items:

- TL3083 pliers for stripping sheaths.
- TL3018 tool for stripping peelable semiconductor.
- TL2294 tool for stripping non-peelable semiconductor.
- TL2998 tool for removing primary insulation.
- PVC carrying case.

TL3081

ALTL1238 Stripping kit

Impact resistant PVC case, equipped with the following items:

- TL3083 pliers for stripping sheaths.
- TL3018 tool for stripping peelable semiconductor.
- TL2994 tool for stripping non-peelable semiconductor.
- TL2998 tool for removing primary insulation.
- TL3058 Isoco.
- TL3062 Isoco.
- TL3066 Isoco.
- PVC carrying case.

NOTE

Ref. **TL4775** includes
18/30 kv isoco.





MEDIUM VOLTAGE CABLE STRIPPERS

USER MANUAL

TL3077 Stripping Pliers



- 1 Place the cable between the guide pulley and blade A, pressing the handles together and moving the tool back and forth.

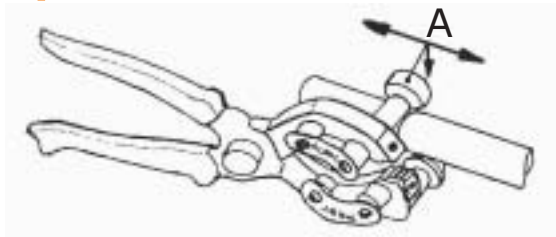

- 3 Realizar el corte circular colocando la pinza en el principio del corte longitudinal y haciéndola girar 45° hacia arriba y abajo.

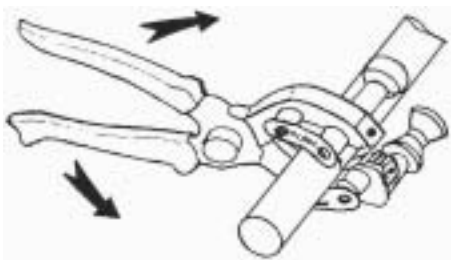

TL3083 Stripping Pliers



- 2 Pull in the direction of the arrow to the end of the cable.

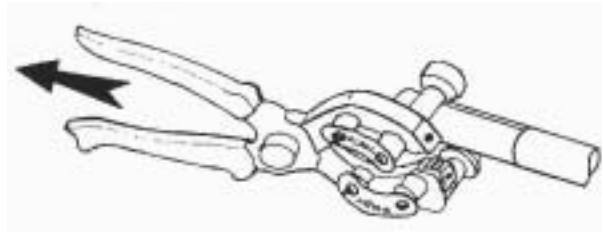

- 4 Retirar la funda del conductor, pellizcándola con las cuchillas separadoras, en la punta del conductor.

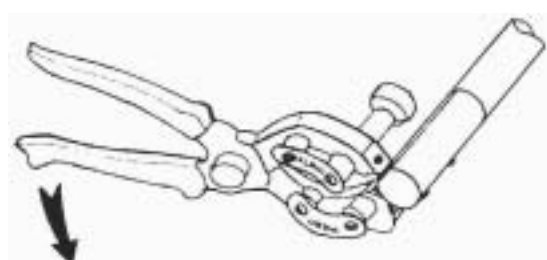

TL3018 Tool for peelable semiconductors

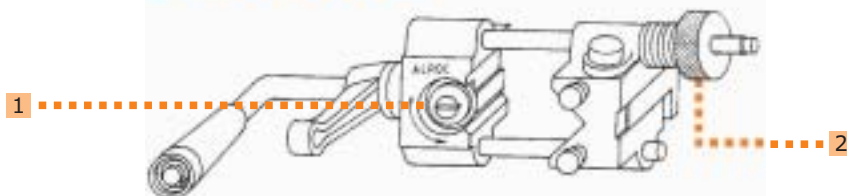

- Loosen nut (2) to open the tool.
- Apply lubricant to the semi-conductive layer. E.g.: vaseline, to facilitate the movement of the tool.
- Thread the tool onto the semi-conductive layer and tighten the nut. (2)
- Regulate the depth of cut of the blade (1) which cuts the semi-conductive layer, by loosening the 2 screws on the reverse side of (1); observe the + and - signs; turn in the appropriate direction and re-tighten the screws.
- Once the blade has been adjusted, begin peeling by rotating the tool in the direction of the arrow; the tool will stop automatically when it reaches the cover of the conductor.
- Loosen nut (2) to remove the tool from the cable.
- Pull the end of the semi-conductive layer away from the insulation; the semi-conductive layer will be removed in a spiral.

MEDIUM VOLTAGE CABLE STRIPPERS

USER MANUAL

TL2994

Tool for non-peelable semiconductors

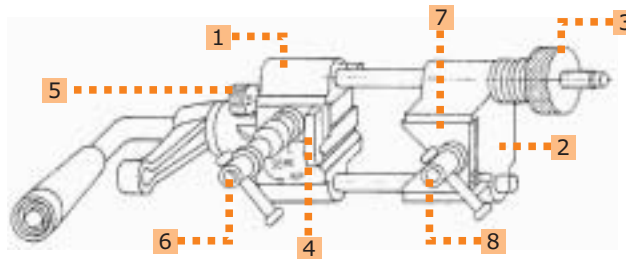

- Loosen nut (8) to regulate the cable guide.
- Loosen nut (6).
- Open the tool by loosening nut (3).
- Apply lubricant to the semi-conductive layer. E.g.: vaseline, to facilitate the movement of the tool.
- Thread the tool onto the conductor to be peeled.
- Tighten parts (1) and (2) against the cable to be peeled and then tighten nut (3).
- Regulate the depth of cut of blade (4) with the adjusting knob (5) and then tighten nut (6).
- Begin peeling the semi-conductive layer by turning the tool in the direction of the arrow, until approximately 10 mm has been cut.
- Move the cable guide (7) forward as far as possible and tighten nut (8).
- Continue turning the tool until the end of the cable; the tool will stop when within 25 mm of the cable cover.

TL2998

Tool for primary insulation

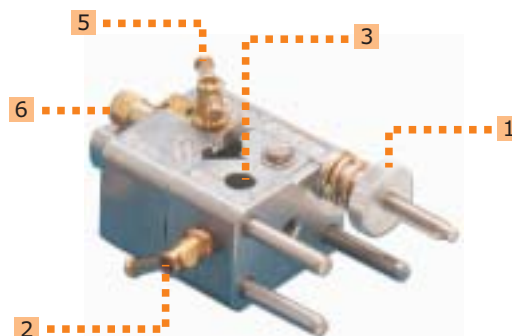

- Loosen nut (1) to open the tool.
- Thread the tool onto the cable and tighten nut (1).
- Loosen nuts (5).
- Adjust the blade of nut (5) with the calibrated regulator (6) as close as possible to the conductor without touching it, and then tighten nut (5).
- Measure the inside length of the terminal or sleeve to be fitted onto the conductor.
- Loosen nut (2) and adjust the calibrated regulator (3) to the same measurement as that of the inside of the terminal, then tighten nut (2).
- Once these adjustments are complete, begin peeling by rotating the tool in the direction of the arrow; the tool will stop automatically when the selected length is reached.
- It is not necessary to lubricate conductors with insulators made of XLPE reticulated polyethylene (white); conductors with insulation made of EPR ethylene propylene (pink) should be lubricated.



MEDIUM VOLTAGE CABLE STRIPPERS

MULTIFUNCTION TOOLS

TL3026

MF3/40 Tool

MF3/40 Tool for peeling the sheath peelable semiconductive layer and insulation. A multipurpose, easy to use, tool, which can do all three operations using one single machine.

- For diameters from 20 to 40 mm.
- Section from 25 to 240 mm².
- Dimensions 165x80x100 mm.
- Weight 1,520 Kg.

TL3027

MF3/60 Tool

MF3/60 Tool for peeling the sheath peelable semiconductive layer and insulation. A multipurpose, easy to use, tool, which can do all three operations using one single machine.

- For diameters from 16 to 58 mm.
- Section from 25 to 630 mm².
- Dimensions 185x90x120 mm.
- Weight 1,650 Kg.

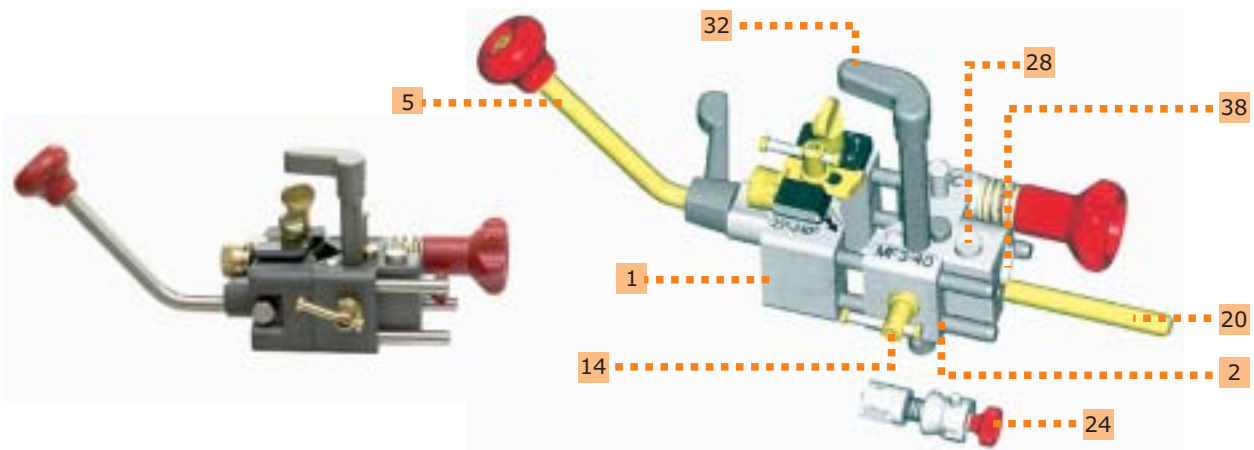

NOTE

The MF3/40 and MF3/60 tools should be used when the cable is unenergised and should be used by personnel competent in cable preparation and with knowledge of electricity. Gloves must be worn.

PREPARATION OF THE TL3026 - TL3027 TOOL

Assembly of the handles

- Assemble the angled handle (5) to the fixed body (1) and the straight handle (20) to the mobile body.

Regulation and assembly of the SR stylus for the peelable semi-conductive layer

- Select the penetration level marked on the scale of the SR stylus.
- Pull and turn the stylus scale to see the penetration level on the blade side.
- Assemble the semi-conductive SR stylus (24) in its slot (38) in the mobile body (2).
- Press button (28) and insert the SR stylus in the mobile body (2), then release the button. Switch the SR stylus (24) to the "OFF" position.

Assembly of the adjustable depth stop

- Assemble the adjustable depth stop (32) to the mobile body (2) and fix it with the set screw (14).

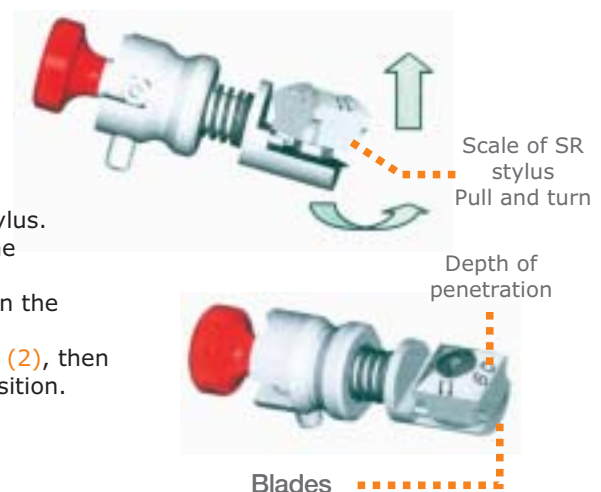

MEDIUM VOLTAGE CABLE STRIPPERS

STRIPPING THE OUTER SHEATH

FIGURE 1 ▶

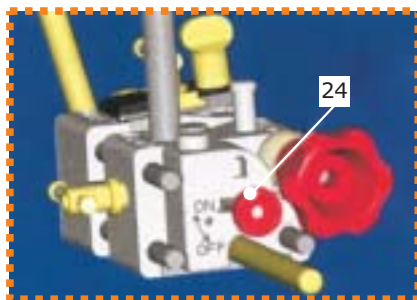
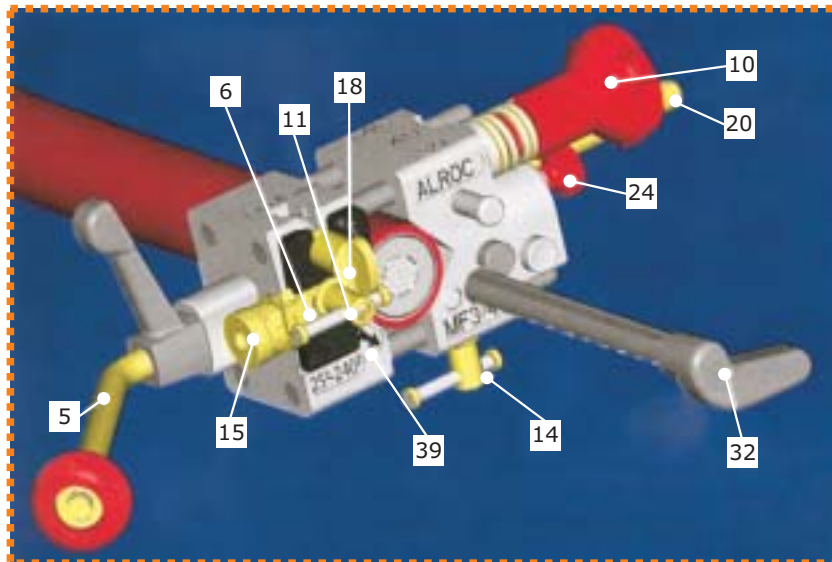

◀ FIGURE 2

NOTE

Do not apply grease to the cable to strip the outer sheath.

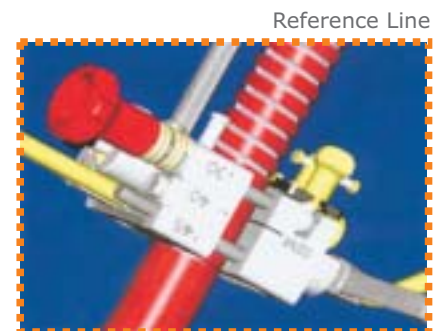

FIGURE 3 ▶

- Draw a reference line on the outer sheath, at the stripping point plus 50 mm for the MF3/40 or plus 52 mm for the MF3/60 (the width of the tool) (Figure 3).
- Check that the semi-conductive stylus (24) is in the "OFF" position (Figure 2).
- Turn the advance button (18) as far as it will go in the (+) direction (Figure 1).
- Place the tool on the cable and tighten nut (10) so that the tool can turn easily on the cable (Figure 1).
- Loosen screw (14) and place the depth stop (32) at 180 degrees so that it does not contact the end of the cable when it is fully out; then re-tighten it (14) (Figure 1).
- Loosen screw (11), regulate and adjust the penetration of the blade (6), using the blade advance button (15), according to the thickness of the sheath, placing the back of the blade as close as possible to the external semi-conductive layer without contacting it (Figure 1).
- Rotate the tool two turns in the direction of the arrow (39) and check the blade regulation (6); adjust it if necessary and then re-tighten screw (11) (Figure 1).
- Strip the sheath until the front of the tool reaches the reference line (Figure 3).
- Turn the advance button (18) as far as it will go in the (-) direction.
- Rotate the tool slowly using the two handles, (5) and (20), to make a clean cut in the sheath.
- Loosen nut (10) sufficiently to remove the tool from the cable without damaging the blade.



MEDIUM VOLTAGE CABLE STRIPPERS

STRIPPING THE PEELABLE SEMI-CONDUCTIVE LAYER

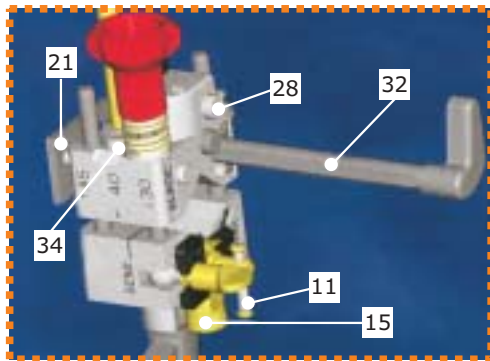

FIGURE 1

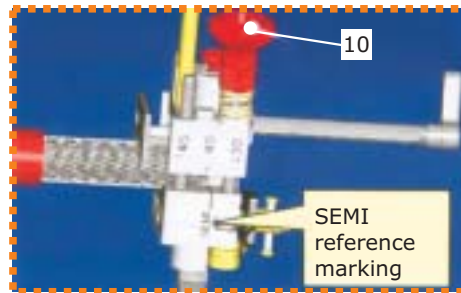

FIGURE 3

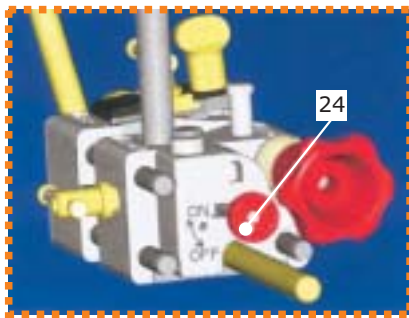
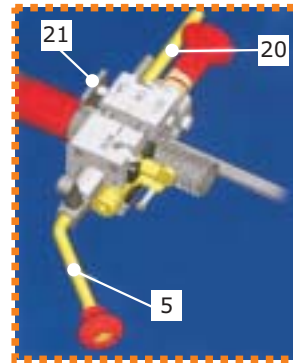

FIGURE 2

FIGURE 4



NOTE

- Do not apply grease to the cable to make the cut in the peelable semi-conductive layer.
- Before carrying out any operations, straighten the cable.
- Verify that the cable has a peelable semi-conductive layer. For non-peelable semi-conductive layers, use the ASC tool.

- Adjust the depth stop (21) to the remaining level of semi-conductive layer (30, 40, 45 or 55 mm), according to the instructions of the accessory, using button (34).
- Loosen screw (11), insert the blade completely with the aid of the blade advance device (15).
- Verify that the depth stop (32) is still turned 180 degrees so that it does not touch the end of the cable.
- Pull the SR semi-conductive stylus (24) and switch it to the "ON" position. **Verify that the blade penetration is correctly regulated** (see Regulation and assembly of the SR stylus (24) above).
- Place the tool over the cable, placing the end of the cable opposite the "SEMI" reference mark, and re-tighten screw (10) **moderately** tight.
- With the aid of handles (5) and (20), push and rotate the tool 2 or 3 turns in the direction of the arrow so that it grips the sheath, strip for several turns (4 cm) and then separate the part of the semi-conductive layer in which you have just made the incision.
- Check that there are no marks on the insulation. (*)
- Continue stripping with the aid of the angled handle (5) until the depth stop (21) contacts the outer sheath, and then rotate the tool two turns more with the depth stop in contact with the sheath.
- Loosen button (10) and remove the tool. (Be careful not to damage the blade when removing the tool). Switch the stylus to the "OFF" position.

- (*) If there are still marks on the insulation, do not remove the MF3/40 or MF3/60 tool
- Pull, turn and place the SR stylus button (24) in the "OFF" position.
- Remove the SR stylus (24) by pressing button (28). Select a different penetration level from those indicated on the stylus scale (see regulation of the stylus, above)
- Place the SR stylus in its slot again pressing button (28)
- Switch it to the "ON" position, and then finish stripping as described above.

MEDIUM VOLTAGE CABLE STRIPPERS

STRIPPING THE INSULATION

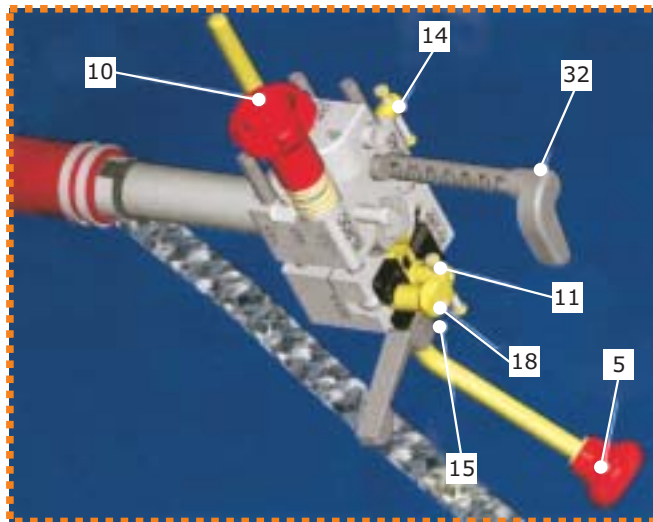

▲ FIGURE 1

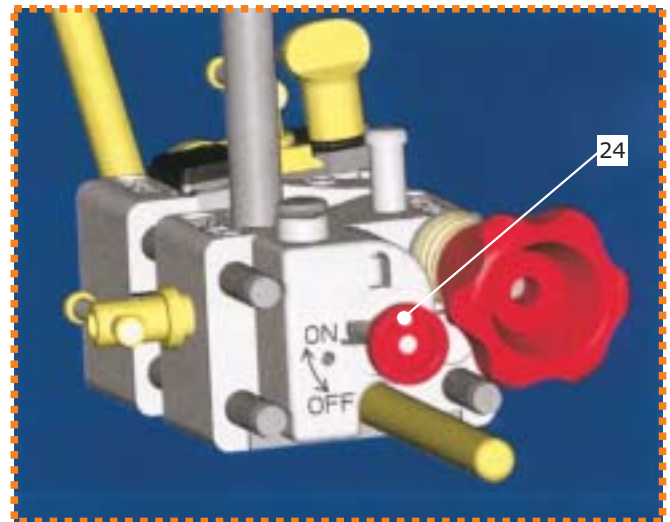

FIGURE 2 ▲



◀ FIGURE 3

NOTE

- Do not apply grease to the cable to strip the insulation.
- After 4 or 5 turns, remove the remains of the insulation from the conductor to avoid them adhering to the latter.
- The MF3/40 and MF3/60 tools should be used when the cable is unenergised and should be used by personnel competent in cable preparation and with knowledge of electricity.
- Gloves must be worn.

- Loosen screw (14), place the depth stop (32) in its slot, regulate the stripping depth (see technical data sheet for the preparation of the cable), and re-tighten screw (14).
- Turn the advance button (18) as far as it will go in the (+) direction.
- Place the tool onto the cable and tighten (moderately) nut (10).
- Check that the semi-conductive stylus (24) is in the "OFF" position.
- Loosen screw (11), regulate and adjust the blade penetration with the aid of the button to advance the blade (15) according to the thickness of the insulation.
- Rotate the tool two turns in the direction of the arrow, check the blade regulation and adjust it if necessary; then re-tighten screw (11).
- Strip the insulation with the aid of the handle (5) until the depth stop (32) contacts the conductor.
- Loosen nut (10) and remove the tool.



MEDIUM VOLTAGE CABLE STRIPPERS

MULTIPURPOSE TOOL KITS

TL1883

PVC case

Impact resistant PVC case, for a variety of different tools and instruments.

- Dimensions 310 x 280 x 100 mm.



TL5372

MF340 Case

Impact resistant PVC case, equipped with the following items:

- MF3/40 tool for peeling the sheath, semiconductor and insulation.

NOTE

Ref. **TL5373**: case with MF3/60 tool.

TL5374

MF340/NP Case

Impact resistant PVC case, equipped with the following items:

- MF3/40 tool for peeling the sheath, semiconductor and insulation.
- ASC25R1 tool for stripping non-peelable semiconductor.

NOTE

Ref. **TL5375**: case with MF3/60 and ASC25R2.



TL5376

MF340/CM Case

Impact resistant PVC case, equipped with the following items:

- MF3/40 tool for peeling the sheath, semiconductor and insulation.
- ASC25R1 tool for stripping non-peelable semiconductor.
- TC095 tool for forming cones. 12/20 Kv.
- TC150 tool for forming cones. 12/20 Kv.
- TC240 tool for forming cones. 12/20 Kv.

NOTE

Ref. **TL5377**: case with MF3/60 and ASC25R2, plus the tools for forming cones.

HIGH VOLTAGE CABLE STRIPPERS

Finally, we offer a range of tools and accessories for preparing high voltage cables from 63 to 400 KV, of any section. These tools remove the sheath, the lead, the non-peelable semiconductor and of course the insulation.

INDIVIDUAL TOOLS

TL3084

PG4 Pliers

PG pliers strip the sheath from single core high voltage cables without adjusting the cutting blades. Thanks to their unique design, it is impossible for the operator to be injured since all the cutting areas are protected.

REFERENCE	MODEL	CAPACITY (mm)	WEIGHT(Kg)
TL3084	PG4*	45 a 75	0,840
TL3085	PG5	65 a 95	2,000
TL3086	PG6	80 a 125	3,000

NOTE

* This tool can also be used for medium voltage cables.



TL3020

Tool for non-peelable semiconductors

For separating non-peelable semi-conductive tape from high voltage cables manufactured using triple extrusion; the tape is vulcanised to the primary insulation, making it extremely difficult to remove using traditional techniques.

REFERENCE	MODEL	CAPACITY (mm)	WEIGHT(Kg)
TL3020	LHS3	60 a 80	3,000
TL5378	ASR70/110	70 a 110	4,600
TL5379	ASR100/150	100 a 150	7,500

To finish, turn the tool 360 degrees resting it on the sheath.



TL3043

Spare Blade

REFERENCE	CAPACITY (mm)
TL3043	60 a 80
TL5380	70 a 110
TL5381	100 a 150





HIGH VOLTAGE CABLE STRIPPERS

TL3009

Tool for primary insulation

For removing primary insulation from high voltage RVH and DVH cables without damaging the

REFERENCE	MODEL	CAPACITY (mm)	WEIGHT (Kg)
TL3009	LH3	60 a 80	3,000
TL3010	LH4	80 a 110	5,900
TL3011	LH5	100 a 140	8,500



MULTIPURPOSE TOOLS

TL3015

LHC3 tool

The LHC3 (ALRROCONE) tool strips semi-conductive tape, creating the cone in the same operation. For conductors from 63 to 400 kV. Supplied in a wooden case.

REFERENCE	MODEL	CAPACITY (mm)	WEIGHT (Kg)
TL3015	LHC3	60 a 80	8
TL3016	LHC4	80 a 110	12,5
TL3017	LHC5	100 a 140	18,5

NOTE

The ALRROCONE tool does not peel cable sheaths: for this purpose, PG4/PG5/PG6 pliers (depending on the diameter of the conductor) should be used.



SPECIAL TOOLS

TL3003

HS700 cutting tool

The HS700 cutting tool cuts cleanly through medium and high voltage conductors. It has a special disc for cutting both aluminium and copper (it cannot cut steel). Supplied in carrying case.



With protective housing to avoid possible accidents.

TL2999

CC/P Sander

The CC/P sander removes any non-peelable semiconductor residue which may be stuck to the cable insulation. Supplied in carrying case.



NOTE

The sander is supplied without sandpaper. Contact our Technical Department for more information.