

LP-172

Pico-ITX

User's Manual

2014/3/14

Version:1.7



Copyright

Copyright 2012. All rights reserved. This document is copyrighted and all rights are reserved. The information in this document is subject to change without prior notice to make improvements to the products.

This document contains proprietary information and protected by copyright. No part of this document may be reproduced, copied, or translated in any form or any means without prior written permission of the manufacturer.

All trademarks and/or registered trademarks contains in this document are property of their respective owners.

Disclaimer

The company shall not be liable for any incidental or consequential damages resulting from the performance or use of this product.

The company does not issue a warranty of any kind, express or implied, including without limitation implied warranties of merchantability or fitness for a particular purpose.

The company has the right to revise the manual or include changes in the specifications of the product described within it at any time without notice and without obligation to notify any person of such revision or changes.

Trademark

All trademarks are the property of their respective holders.

Any questions please visit our website at <http://www.commell.com.tw>

Packing List:

Please check the package content before you starting using the board.

Hardware:

LP-172 Pico-ITX Miniboard x 1

Cable Kit:

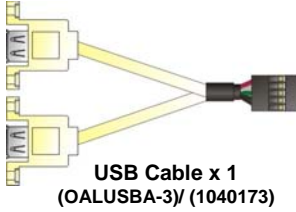

USB Cable x 1
(OALUSBA-3)/ (1040173)

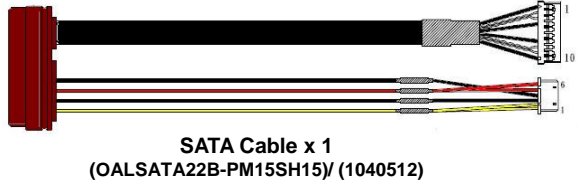

SATA Cable x 1
(OALSATA22B-PM15SH15)/ (1040512)



Dual COM PORT cable
(OALES-BKU2NB)/ (1040090)

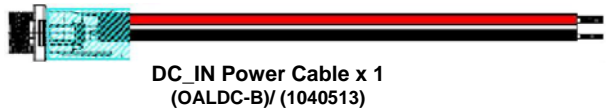

DC_IN Power Cable x 1
(OALDC-B)/ (1040513)



Audio Cable x 1
(OALPJ-HDUNB)/ (1040123)

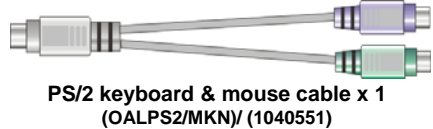

PS/2 keyboard & mouse cable x 1
(OALPS2/MKN)/ (1040551)



LP-172N Heatsink x 1
(OHS-172)/ (2181110001)

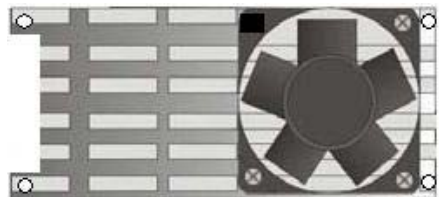

LP-172D5 Heatsink with Fan x 1
(OHS-172F)/ (2181010013)

Printed Matters:

Driver CD x 1 (Including User's Manual)

Index

Chapter 1 <Introduction>	6
1.1 <Product Overview>	6
1.2 <Product Specification>	7
1.3 <Mechanical Drawing>	9
1.4 <Block Diagram>	10
Chapter 2 <Hardware Setup>	11
2.1 <Connector Location>	11
2.2 <Jumper Reference>	13
2.3 <Connector Reference>	14
2.3.1 <Internal Connector>	14
2.3.2 <External Connector>	14
2.4 <Memory Setup>	15
2.5 <CMOS & ATX Setup>	16
2.6 <SATA Interface>	17
2.7 <LAN Interface>	18
2.8 <Onboard Display Interface>	19
2.8.1 <Analog VGA Interface>	19
2.8.2 <CN_LVDS>	20
2.9 <Onboard Audio Interface>	24
2.10 <USB2.0 Interface>	25
2.11 <Serial Port Jumper Setting >	26
2.12 <Power & FAN Connector >	27
2.12.1 <Power Input>	27
2.12.2 <Power Output>	28
2.12.3 <Fan Connector>	29
2.13 <Indicator and Switch>	30
Chapter 3 <BIOS Setup>	32
Appendix A <I/O Port Pin Assignment>	34
A.1 <SATA Port>	34

A.2 <CRT Port>	34
A.3 <LAN Port>	34
A.4 <LAN LED Port>	35
A.5 <LPC Port>	35
Appendix B <Flash BIOS>	36
B.1 BIOS Auto Flash Tool	36
B.2 Flash Method	36
Appendix C <System Resources>	37
C.1 <I/O Port Address Map>	37
C.2 <Memory Address Map>	39
C.3 <System IRQ Resources>	40
Appendix D <Watch Dog timer Setting>	43
Contact Information	45

(This page is left for blank)

Chapter 1 <Introduction>

1.1 <Product Overview>

LP-172 is the PICO-ITX miniboard with Intel® Atom™ CedarTrail Processor with optional D2550 or N2800 platform, Intel® NM10, integrated Intel® GMA 3650 graphics, DDR3 SO-DIMM memory, Realtek ALC888 HD Codec audio and one Intel® 82583V Giga LAN.

Intel® Atom D2550 Processor

The Intel® Atom D2550 Dual core processor is with, 1.86GHz clock Speed, 1MB L2 cache. It's built on 32nm process technology support Hyper-Threading Technology, Intel® 64.

Intel® Atom N2800 Processor

The Intel® Atom N2800 Dual core processor is with, 1.86GHz clock Speed, 1MB L2 cache. It's built on 32nm process technology support Hyper-Threading Technology, Enhanced Intel Speedstep® Technology, Intel® 64.

Intel® NM10 Chipset

The board integrates Intel® NM10. The chipset features power-efficient graphics with an integrated 32-bit 3D graphics engine based on Intel® Graphics Media Accelerator 3650 architecture with DVI, LVDS, CRT display ports. It provides I/O capabilities and flexibility via high-bandwidth interfaces such as PCIE and Hi-Speed USB 2.0 connectivity. It also includes a single channel for 1066 MHz DDR3 system memory (SODIMM), HD Audio.

Flexible Extension Interface

The board also provides one Mini card socket.

1.2 <Product Specification>

General Specification

Form Factor	PICO-ITX miniboard
CPU	Intel® Atom™ CedarTrail Processor with optional D2550 or N2800
Memory	1 x 204-pin DDR3 800/1066 SO-DIMM SDRAM up to 4G
Chipset	Intel® NM10
Watchdog Timer	System reset programmable watchdog timer with 1 ~ 255 sec./min. of timeout value
Real Time Clock	Chipset integrated RTC with onboard lithium battery
Serial ATA	1 x serial ATAll interface with 300MB/s transfer rate (No RAID Function)

Multi-I/O Port

Chipset	Winbond W83627DHG-P
Serial Port	Two RS-232 serial port
USB Port	Four Hi-Speed USB 2.0 ports with 480Mbps of transfer rate
K/B & Mouse	PS/2 keyboard and mouse port

VGA Display Interface

Chipset	Intel® integrated extreme GMA 3650
Display Type	CRT, LCD monitor with analog display, single channel LVDS
Connector	External DB15 female connector Onboard 20-Pin LVDS and 5-Pin inverter connector

Ethernet Interface

Controller	1 x Intel® 82583V Gigabit Ethernet controller
Type	Triple speed 10/100/1000Base-T auto-switching Fast Ethernet Full duplex, IEEE802.3U compliant
Connector	1 X External RJ45 connector with LED

Audio Interface

Chipset	REALTEK ALC888
Interface	Stereo audio Line-out and MIC-in
Connector	Onboard audio connector with pin header

Expansive Interface

PCIE Mini Card	1 x PCIE Mini Card socket
----------------	---------------------------

Power and Environment

Power Requirement	DC only +5V input with onboard 2-pin connector
Dimension	100 (L) x 72(H) mm
Temperature	Operating within 0 ~ 60°C Storage within -20 ~ 85°C

Ordering Code

LP-172D5	Support Intel® Atom™ CedarTrail D2550 processor with onboard VGA, 18 or 24 bit LVDS , Audio, Giga LAN, USB2.0 .SATAII, PCIE mini card
LP-172D5S	Support Intel® Atom™ CedarTrail D2550 processor with onboard VGA, 18 or 24 bit LVDS , Audio, Giga LAN, USB2.0 .SATAII, PCIE mini card mSATA
LP-172N	Support Intel® Atom™ CedarTrail N2800 processor with onboard VGA, 18 bit LVDS , Audio, Giga LAN, USB2.0 .SATAII, PCIE mini card
LP-172NS	Support Intel® Atom™ CedarTrail N2800 processor with onboard VGA, 18 bit LVDS , Audio, Giga LAN, USB2.0 .SATAII, PCIE mini card mSATA

The specifications may be different as the actual production.

For further product information please visit the website at <http://www.commell.com.tw>

1.4 <Block Diagram>

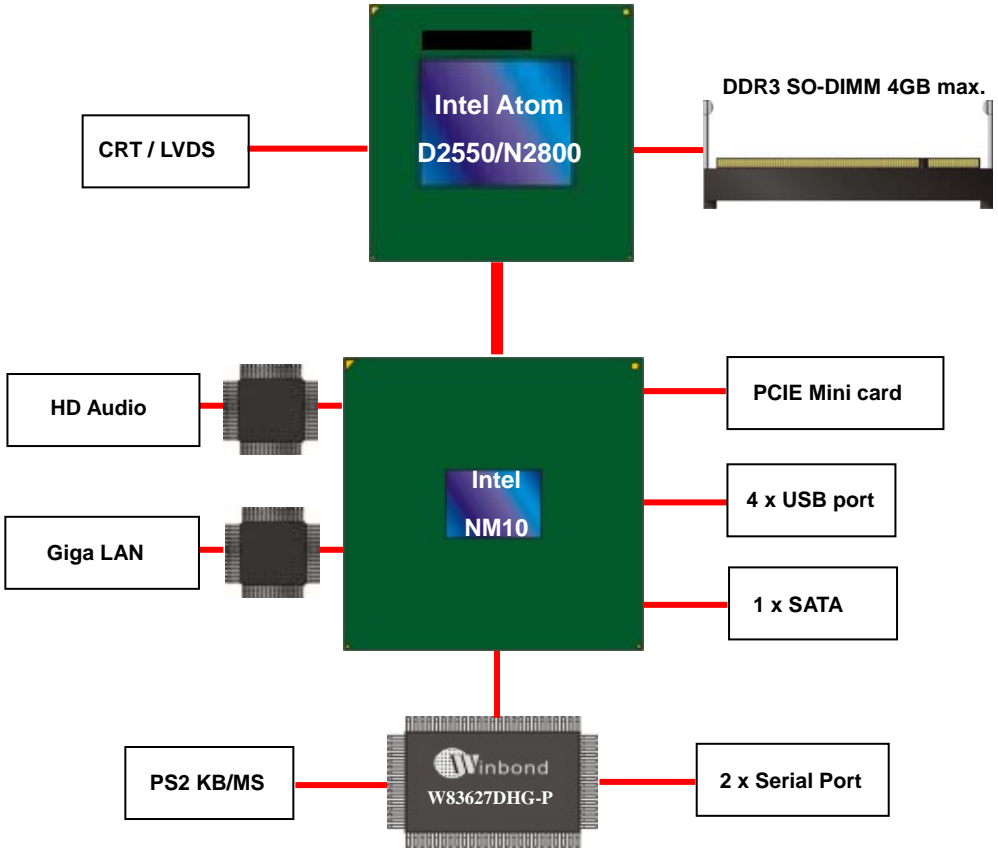

Chapter 2 <Hardware Setup>

2.1 <Connector Location>

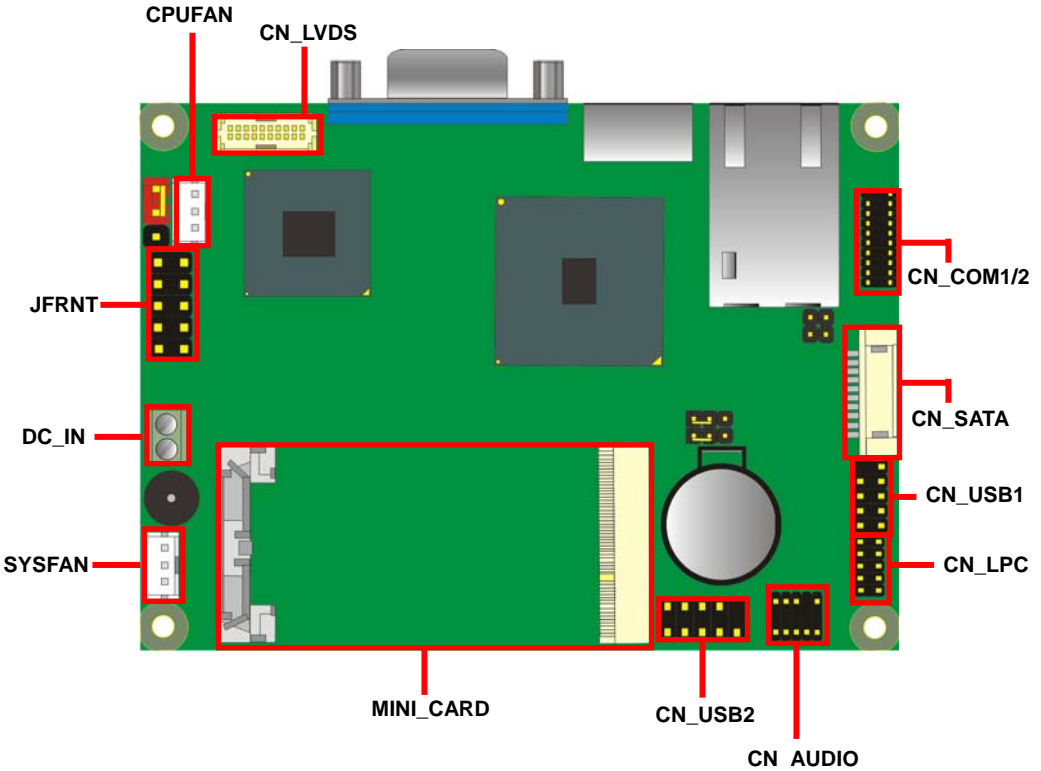

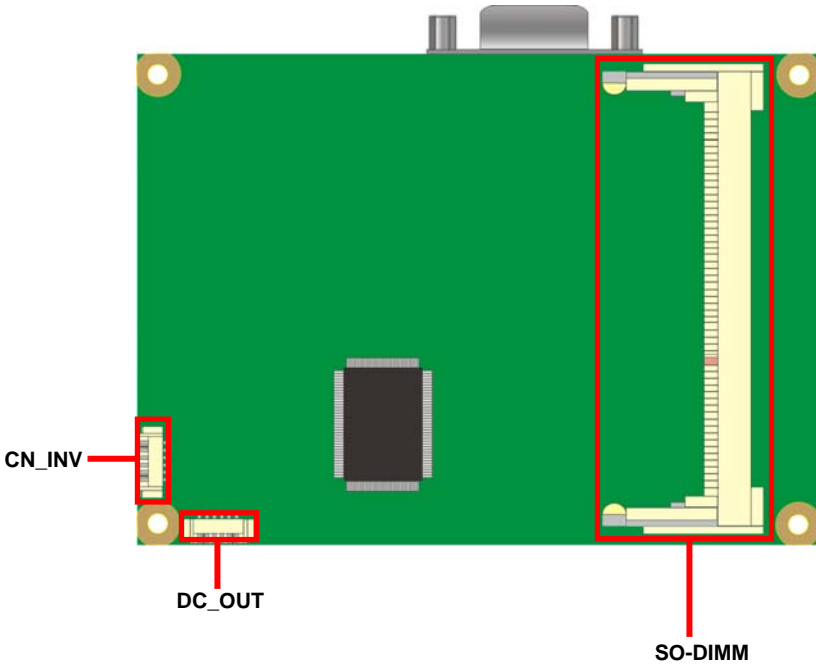

LP-172



2.2 <Jumper Reference>

Jumper	Function
JRTC	CMOS Operating/Clear Setting
JAT	AT/ATX Mode Setting
JVLCD	LCD Panel Voltage Setting

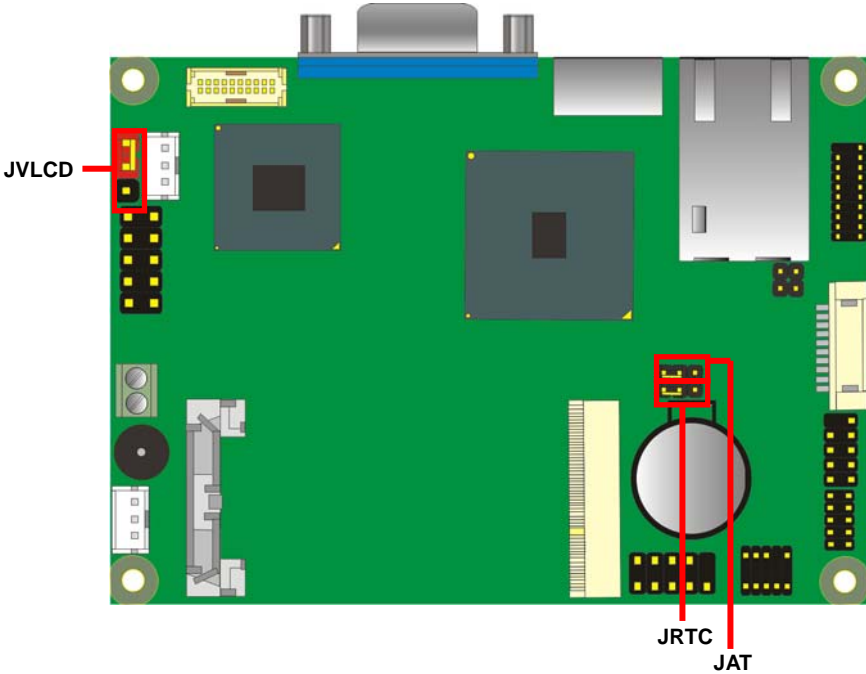

2.3 <Connector Reference>

2.3.1 <Internal Connector>

Connector	Function	Remark
SO-DIMM	204 -pin DDR3 SO-DIMM SDRAM slot	
CN_SATA	10-pin SATA Cable connector	
MINI_CARD	PCIE mini card socket	
CN_INV	5-pin LCD inverter connector	
CN_USB1/2	5 x 2-pin USB connector	
CN_AUDIO	5 x 2-pin audio connector	
CN_LPC	5 x 2-pin header for LPC Port	
CN_COM1/2	10 x 2-pin com connector	
JFRNT	10-pin switch/indicator connector	
CPUFAN	4-pin CPU cooler fan connector	
SYSFAN	3-pin system cooler fan connector	
DC_OUT	6-pin power output connector	
DC_IN	DC input connector	

2.3.2 <External Connector>

Connector	Function	Remark
CRT	DB15 VGA connector	
PS2	PS/2 keyboard and mouse connector	
RJ45	RJ45 LAN connector	

2.4 <Memory Setup>

Non-ECC, unbuffered memory is supported only.

The board provides one 204-pin DDR3 SO-DIMM to support DDR3 800/1066 memory modules up to 4GB.

Suggestion:

DDR3 SO-DIMM Modules:

- Raw Card C = Single-sided x 8
- Raw Card F = Double-sided x 8

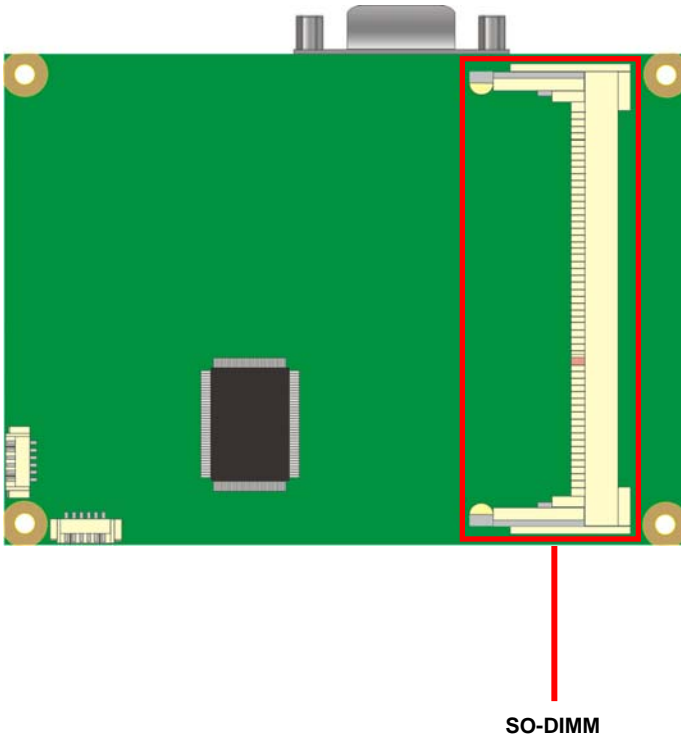

2.5 <CMOS & ATX Setup>

The board's data of CMOS can be setting in BIOS. If the board refuses to boot due to inappropriate CMOS settings, please remove battery to clear (reset) the CMOS to its default values.

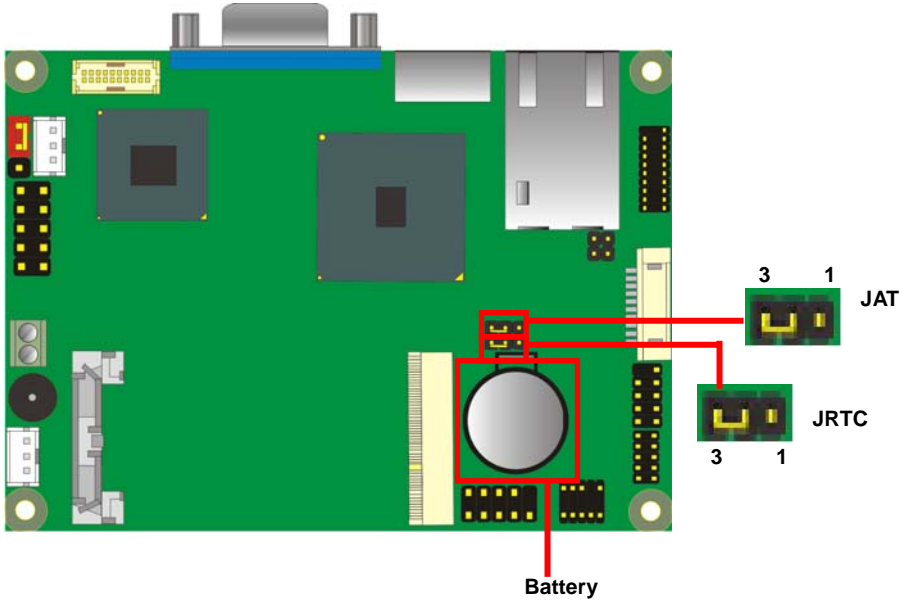

The board has a jumper to switch AT power mode (automatic power on) or standard ATX mode.

Jumper: **JAT**

Type: onboard 3-pin jumper

JAT	Mode
1-2	AT Mode
2-3	ATX Mode

Default setting

Jumper: **JRTC**

Type: onboard 3-pin jumper

JRTC	Mode
1-2	Clear CMOS
2-3	Normal Operation

Default setting

2.6 <SATA Interface>

Based on Intel NM10, the board provides one Serial ATAII interfaces with up to 300MB/s of transfer rate.

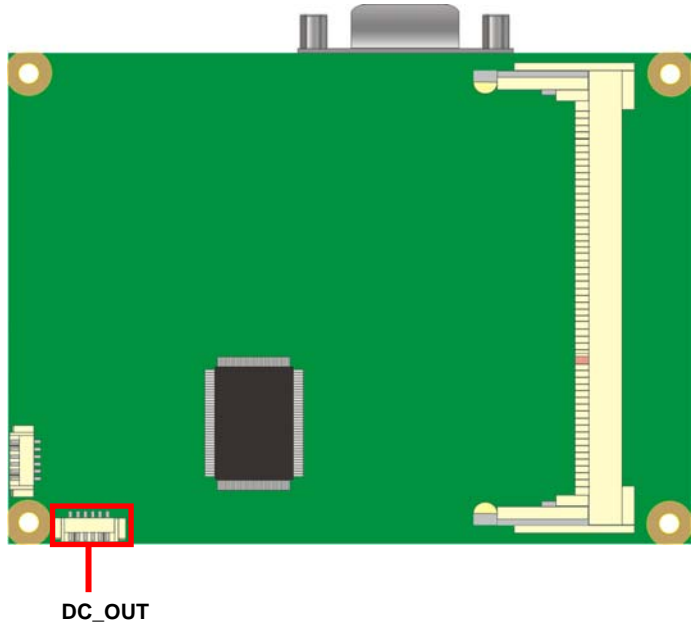
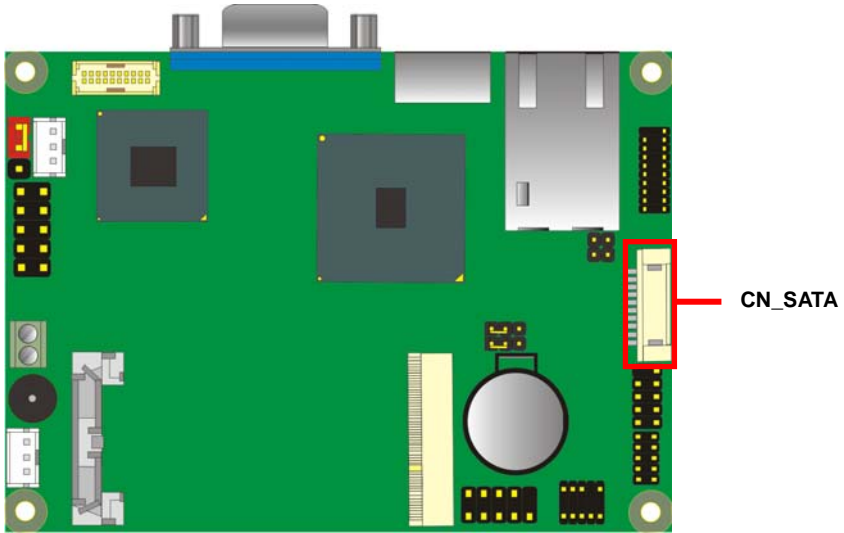

2.7 <LAN Interface>

The Intel® 82583V supports triple speed of 10/100/1000Base-T, with IEEE802.3 compliance and Wake-On-LAN supported.



2.8 <Onboard Display Interface>

Based on Intel Atom CedarTrail Processor chipset with built-in Intel® integrated extreme GMA 3650, the board provides one DB15 connector on real external I/O port, and LVDS interface with 5-pin LCD backlight inverter connector. The board provides dual display function with clone mode and extended desktop mode for CRT and LVDS.

2.8.1 <Analog VGA Interface>

Please connect your CRT or LCD monitor with DB15 male connector to the onboard DB15 female connector on rear I/O port.

The board supports up to 1920 x 1080 (WUXGA) of resolution.

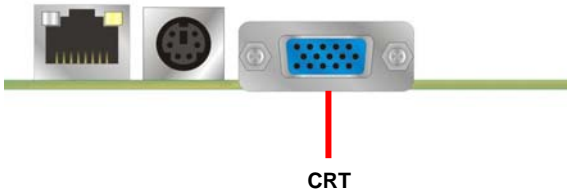

2.8.2 <CN_LVDS>

The board provides one 20-pin LVDS connector for 18 bit or 24bit single channel panel, with one LCD backlight inverter connector and one jumper for panel voltage setting.

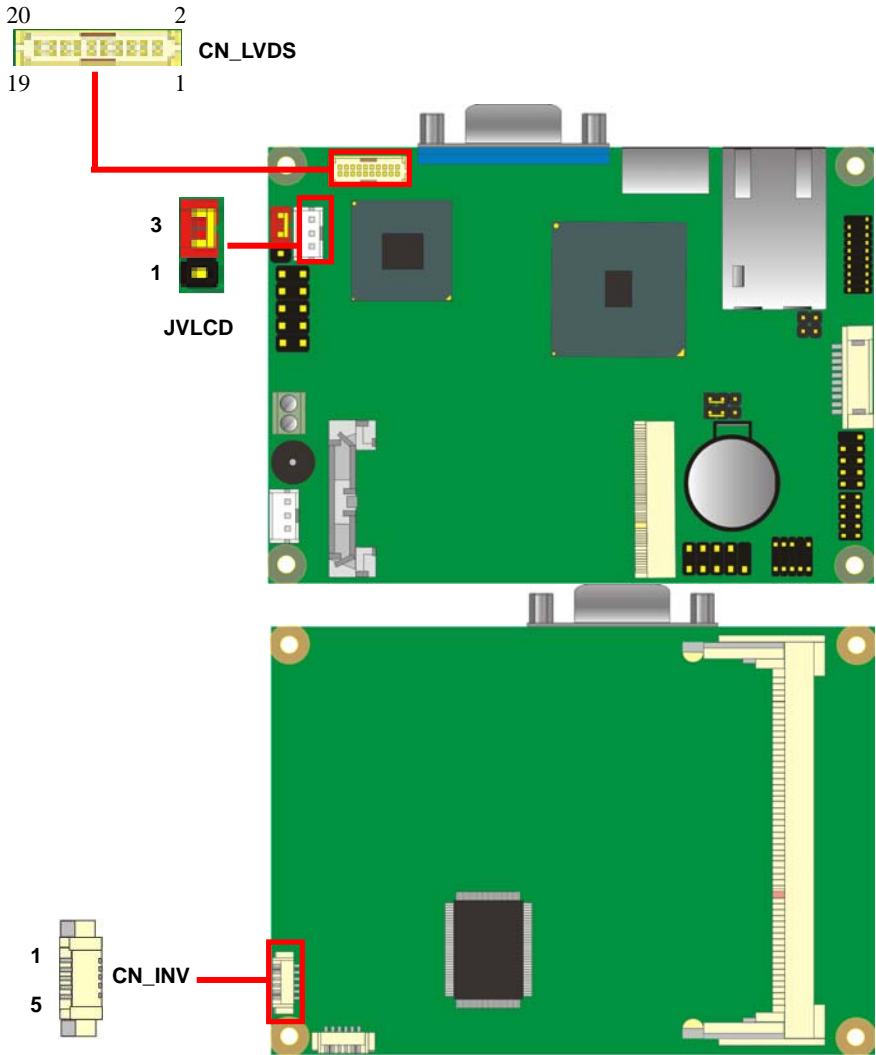

Connector: **CN_INV**

Type: 5-pin Inverter power connector

Connector model: **molex_53261-5pin** or compatible

Pin	Description
1	+3.3V
2	CTLBKL
3	+5V
4	GND
5	Enable

Jumper: **JVLCD**

Type: 3-pin Power select jumper

Pin	Description
1-2	+5V
2-3	+3.3V

Default: 2-3

Connector: **CN_LVDS** Type: onboard 20-pin connector for LVDS connector

Connector model:

E&T 3950-B20C-00R or similar (**HIROSE DF13-20DP-1.25V** compatible)

Pin	Signal	Pin	Signal
1	LCDVCC	2	LCDVCC
3	NC	4	GND
5	TX0N	6	TX0P
7	GND	8	TX1N
9	TX1P	10	GND
11	TX2N	12	TX2P
13	GND	14	TXCN
15	TXCP	16	GND
17	TXL3N (LP-172D5)	18	TXL3P (LP-172D5)
19	NC	20	NC

LP-172 User's Manual

To setup the LCD, you need the component below:

1. A panel with LVDS interfaces.
2. An inverter for panel's backlight power.
3. A LCD cable and an inverter cable.

For the cables, please follow the pin assignment of the connector to make a cable, because every panel has its own pin assignment, so we do not provide a standard cable; please find a local cable manufacture to make cables.

LCD Installation Guide:

1. Preparing the LP-172, LCD panel and the backlight inverter

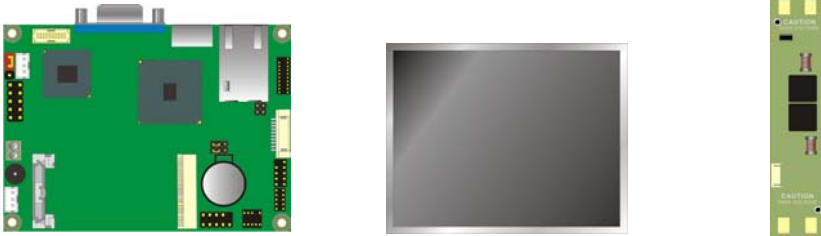

2. You would need a LVDS type cable.



3. To connect all of the devices well.

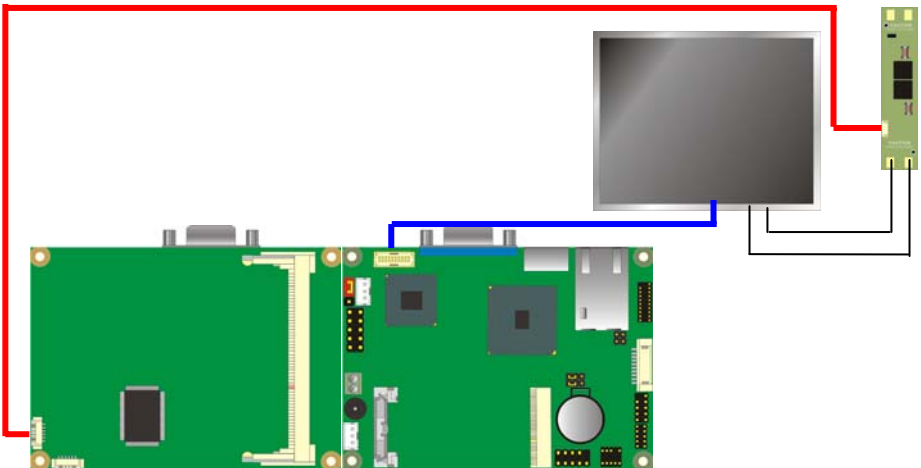

After setup the devices well, you need to select the LCD panel type in the BIOS.

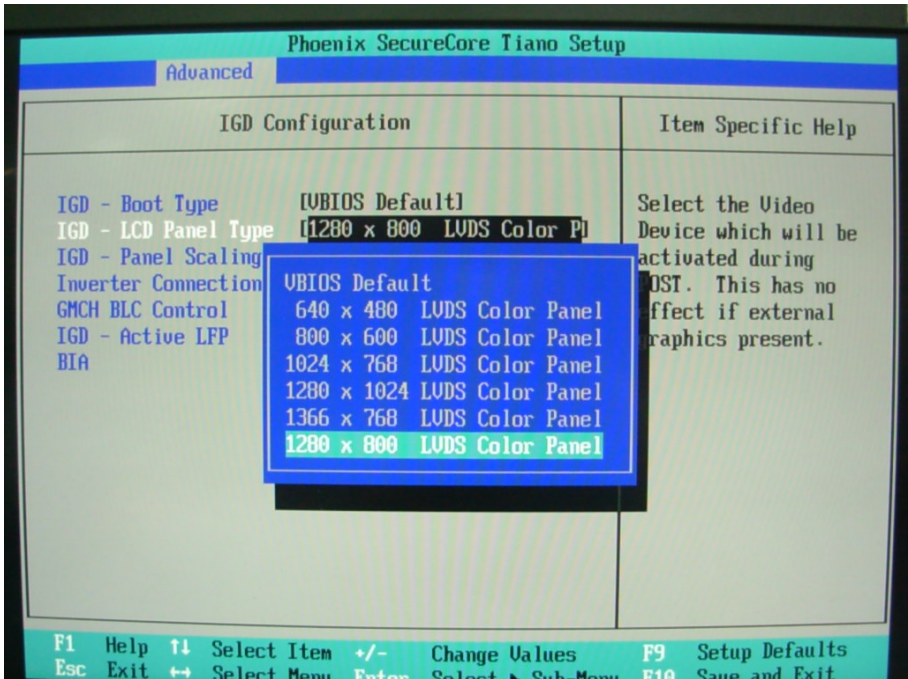

The panel type mapping is list below:

LP-172 BIOS panel type selection form		
On board Single channel LVDS		
	18bit (LP-172N)	24bit (LP-172D5)
NO.	Output format	Output format
1	640 x 480	640 x 480
2	800 x 600	800 x 600
3	1024 x 768	1024 x 768
4	1280 x 1024	1280 x 1024
5	1366 x 768	1366 x 768
6	1280 x 800	1280 x 800

2.9 <Onboard Audio Interface>

The board provides the onboard high definition audio with Realtek ALC888

Connector: CN_AUDIO

Type: 10-pin (2 x 5) 1.27mm x 2.54mm-pitch header

Pin	Description	Pin	Description
1	MIC2_L	2	AGND
3	MIC2_R	4	AVCC
5	FP_OUT_R	6	MIC2_JD
7	SENSE_B	8	N/C
9	FP_OUT_L	10	LINE2_JD

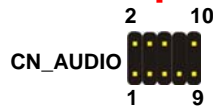
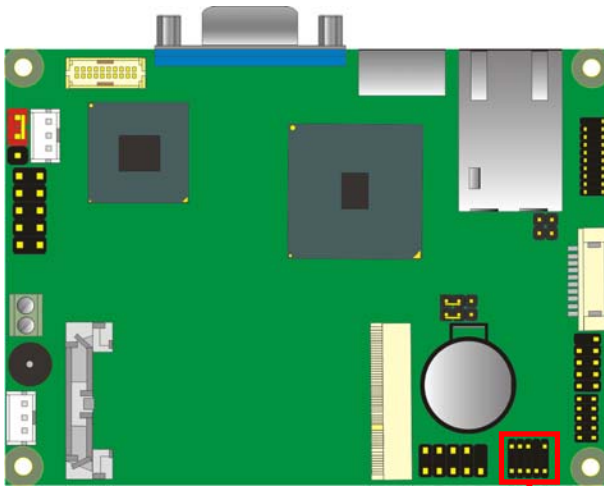

2.10 <USB2.0 Interface>

Based on Intel® NM10 FCH, the board provides 4 USB2.0 ports. The USB2.0 interface provides up to 480Mbps of transferring rate.

Interface	USB2.0
Controller	NM10
Transfer Rate	Up to 480Mb/s
Output Current	500mA

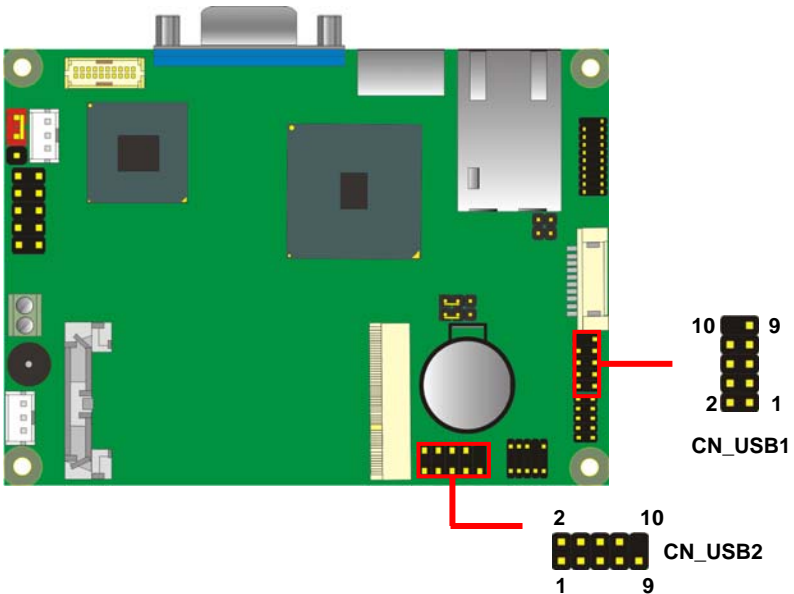

Connector: **CN_USB**

Type: 10-pin (5 x 2) header for USB Port

Pin	Description	Pin	Description
1	VCC	2	VCC
3	Data0-	4	Data1-
5	Data0+	6	Data1+
7	Ground	8	Ground
9	Ground	10	N/C

PS: The USB2.0 will be only active when you connecting with the USB2.0 devices, if you insert an USB1.1 device, the port will be changed to USB1.1 protocol automatically. The transferring rate of USB2.0 as 480Mbps is depends on device capacity, exact transferring rate may not be up to 480Mbps.

2.11 <Serial Port Jumper Setting >

The board provides two RS232 serial ports

Connector: **CN_COM1/2**

Type: 20-pin (5 x 2) 1.27mm x 2.54mm-pitch header for COM1/2

Pin	Description	Pin	Description
1	MDCD1-	2	MSIN1-
3	MSO1-	4	MDTR1-
5	N/C	6	MDSR1-
7	MRTS1-	8	MCTS1-
9	MRI1-	10	N/C
11	MDCD2-	12	MSIN2-
13	MSO2-	14	MDTR2-
15	GND	16	MDSR2-
17	MRTS2-	18	MCTS2-
19	MRI2-	20	N/C

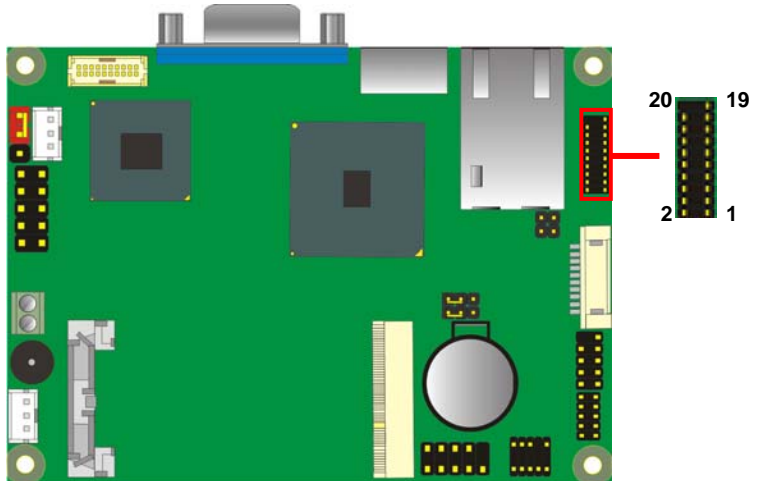

2.12 <Power & FAN Connector >

The board requires DC input with 2-pin header, the input voltage range is from 5V for the input current, please take a reference of the power consumption report on appendix.

2.12.1 <Power Input>

Connector: DC_IN

Type: 2-pin header

Pin	Description	Pin	Description
1	Ground	2	+5V

Remark: DC input voltage only +5V

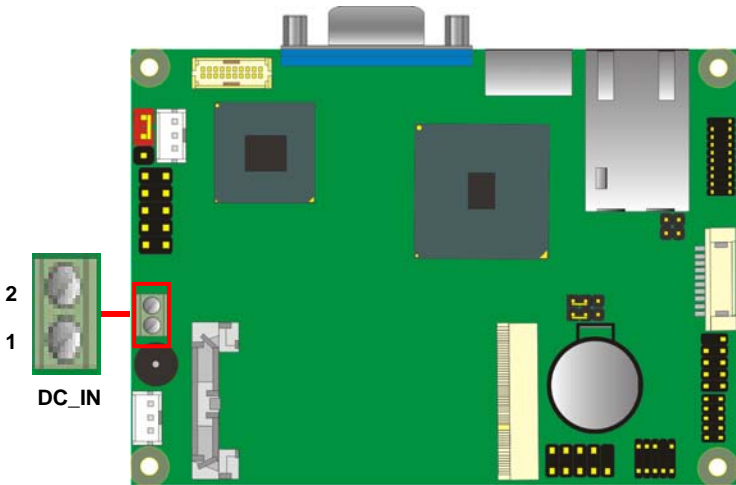

2.12.2 <Power Output>

Connector: **DC_OUT**

Type: 6-pin connector for **+5V output**

Pin	Description	Pin	Description	Pin	Description
1	N/C	2	N/C	3	Ground
4	Ground	5	+5V	6	+5V

Note: Maximum output current 5V/1A

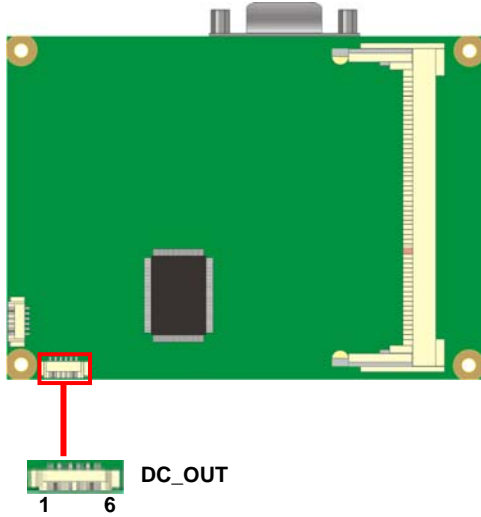

2.12.3 <Fan Connector>

Connector: **SYSFAN**

Type: 3-pin fan wafer connector

Connector model: **2001-WS-03-LF**

Pin	Description	Pin	Description	Pin	Description
1	Ground	2	+5V	3	CSFAN

Connector: **CPUFAN**

Type: 3-pin fan wafer connector

Connector model: **2001-WS-03-LF**

Pin	Description
1	Ground
2	+5V
3	P1FAN

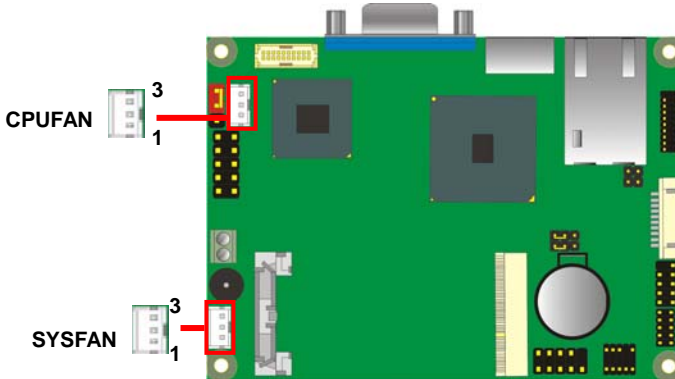

2.13 <Indicator and Switch>

The **JFRNT** provides front control panel of the board, such as power button, reset and beeper, etc. Please check well before you connecting the cables on the chassis.

Connector: **JFRNT**

Type: onboard 10-pin (2 x 5) 2.54-pitch header

Function	Signal	PIN		Signal
Power	PWRBT-	1	2	PWRBT+
Speaker	SPK-	3	4	SPK+
HDD LED	HLED-	5	6	HLED+
Power LED	GND	7	8	PWLED+
Reset	Reset-	9	10	GND

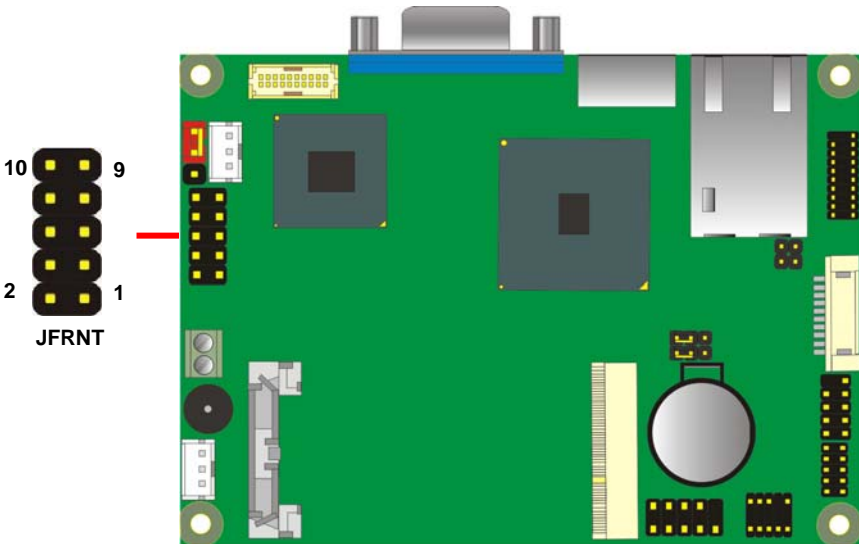

(This Page is Left For Blank)

Chapter 3 <BIOS Setup>

The motherboard uses the Phoenix BIOS for the system configuration. The Phoenix BIOS in the single board computer is a customized version of the industrial standard BIOS for IBM PC AT-compatible computers. It supports Intel® x86 and compatible CPU architecture based processors and computers. The BIOS provides critical low-level support for the system central processing, memory and I/O sub-systems.

The BIOS setup program of the single board computer let the customers modify the basic configuration setting. The settings are stored in a dedicated battery-backed memory, NVRAM, retains the information when the power is turned off. If the battery runs out of the power, then the settings of BIOS will come back to the default setting.

The BIOS section of the manual is subject to change without notice and is provided here for reference purpose only. The settings and configurations of the BIOS are current at the time of print, and therefore they may not be exactly the same as that displayed on your screen.

To activate CMOS Setup program, press key immediately after you turn on the system. The following message “Press DEL to enter SETUP” should appear in the lower left hand corner of your screen. When you enter the CMOS Setup Utility, the Main Menu will be displayed as **Figure 4-1**. You can use arrow keys to select your function, press <Enter> key to accept the selection and enter the sub-menu.

Figure 4-1 CMOS Setup Utility Main Screen



(This Page is Left for Blank)

Appendix A <I/O Port Pin Assignment>

A.1 <SATA Port>

Connector: SATA

Type: 10-pin header for SATA Port

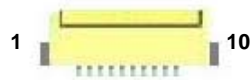

Pin	Description	Pin	Description
1	Ground	2	TXP
3	TXN	4	Ground
5	N/C	6	N/C
7	Ground	8	RXN
9	RXP	10	Ground

A.2 <CRT Port>

Connector: CRT

Type: 15-pin D-sub female connector on rear panel

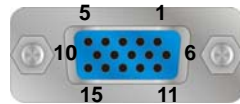

Pin	Description	Pin	Description	Pin	Description
1	RED	6	Ground	11	N/C
2	GREEN	7	N/C	12	5VCD A
3	BLUE	8	Ground	13	HSYNC
4	N/C	9	LVGA5V	14	VSYNC
5	-CRTATCH	10	-CRTATCH	15	5VCLK

A.3 <LAN Port>

Connector: RJ45

Type: RJ45 connector with LED on rear panel

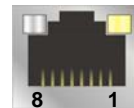

Pin	1	2	3	4	5	6	7	8
Description	TRD0+	TRD0-	TRD1+	TRD2+	TRD2-	TRD1-	TRD3+	TRD3-

A.4 <LAN LED Port>

Connector: **JSPD1**

Type: 2-pin header for LAN Speed LED connector RJ45 connector with LED on rear panel

When Lan speed 10/100Mbps

Pin	Description
1	LED-
2	LED+

When Lan speed 1Gbps

Pin	Description
1	LED+
2	LED-

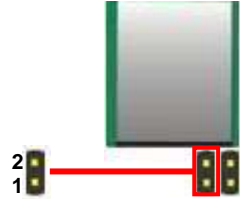

Connector: **JACT**

Type: 5-pin header for LAN Activity LED connector

Pin	Description
1	LED-
2	LED+

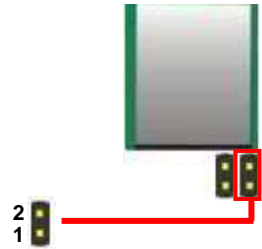

A.5 <LPC Port>

Connector: **JSPD1**

Type: 10-pin header for LPC Port

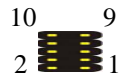

Pin	Description	Pin	Description
1	LPC_CLK	2	RESET-
3	LFRAME-	4	LAD3
5	LAD2	6	LAD1
7	LAD0	8	+3.3V
9	Ground	10	Ground

Appendix B <Flash BIOS>

B.1 BIOS Auto Flash Tool

The board is based on phoenix BIOS and can be updated easily by the BIOS auto flash tool. You can download the tool online at the address below:

<http://www.phoenix.com/en/home/>

http://www.commell.com.tw/Support/Support_SBC.htm

File name of the tool is "Pflash.exe", it's the utility that can write the data into the BIOS flash ship and update the BIOS.

B.2 Flash Method

1. Please make a bootable floppy disk.
2. Get the last .bin files you want to update and copy it into the disk.
3. Copy awardflash.exe to the disk.
4. Power on the system and flash the BIOS.
(Example: C:/Pflash /sa /bbl /cvar XXX.bin)
5. Re-star the system.















Any question about the BIOS re-flash please contact your distributors or visit the web-site at below:

<http://www.commell.com.tw/support/support.htm>

Appendix C <System Resources>

C.1 <I/O Port Address Map>

Input/output (I/O)	
[00000000 - 0000001F]	Direct memory access controller
[00000000 - 00000CF7]	PCI bus
[00000020 - 00000021]	Programmable interrupt controller
[00000024 - 00000025]	Programmable interrupt controller
[00000028 - 00000029]	Programmable interrupt controller
[0000002C - 0000002D]	Programmable interrupt controller
[0000002E - 0000002F]	Motherboard resources
[00000030 - 00000031]	Programmable interrupt controller
[00000034 - 00000035]	Programmable interrupt controller
[00000038 - 00000039]	Programmable interrupt controller
[0000003C - 0000003D]	Programmable interrupt controller
[00000040 - 00000043]	System timer
[0000004E - 0000004F]	Motherboard resources
[00000050 - 00000053]	System timer
[00000060 - 00000060]	Standard PS/2 Keyboard
[00000061 - 00000061]	Motherboard resources
[00000063 - 00000063]	Motherboard resources
[00000064 - 00000064]	Standard PS/2 Keyboard
[00000065 - 00000065]	Motherboard resources
[00000067 - 00000067]	Motherboard resources
[00000070 - 00000070]	Motherboard resources
[00000070 - 00000077]	System CMOS/real time clock
[00000080 - 00000080]	Motherboard resources
[00000081 - 00000091]	Direct memory access controller
[00000092 - 00000092]	Motherboard resources
[00000093 - 0000009F]	Direct memory access controller
[000000A0 - 000000A1]	Programmable interrupt controller
[000000A4 - 000000A5]	Programmable interrupt controller
[000000A8 - 000000A9]	Programmable interrupt controller
[000000AC - 000000AD]	Programmable interrupt controller
[000000B0 - 000000B1]	Programmable interrupt controller
[000000B2 - 000000B3]	Motherboard resources
[000000B4 - 000000B5]	Programmable interrupt controller
[000000B8 - 000000B9]	Programmable interrupt controller
[000000BC - 000000BD]	Programmable interrupt controller
[000000C0 - 000000DF]	Direct memory access controller
[000000F0 - 000000F0]	Numeric data processor
[000002F8 - 000002FF]	Communications Port (COM2)
[000003B0 - 000003BB]	Intel(R) Graphics Media Accelerator 3600 Series
[000003C0 - 000003DF]	Intel(R) Graphics Media Accelerator 3600 Series
[000003F8 - 000003FF]	Communications Port (COM1)
[00000400 - 0000047F]	Motherboard resources
[000004D0 - 000004D1]	Programmable interrupt controller
[00000500 - 0000057F]	Motherboard resources
[00000600 - 0000061F]	Motherboard resources
[00000680 - 0000069F]	Motherboard resources
[000006A0 - 000006AF]	Motherboard resources
[000006B0 - 000006FF]	Motherboard resources
[00000D00 - 0000FFFF]	PCI bus



















































-  [00001000 - 0000100F] Motherboard resources
-  [00001010 - 00001013] Motherboard resources
-  [00002000 - 00002FFF] Intel(R) N10/ICH7 Family PCI Express Root Port - 27D0
-  [00003020 - 0000303F] Intel(R) N10/ICH7 Family USB Universal Host Controller - 27CB
-  [00003040 - 0000305F] Intel(R) N10/ICH7 Family USB Universal Host Controller - 27CA
-  [00003060 - 0000307F] Intel(R) N10/ICH7 Family USB Universal Host Controller - 27C9
-  [00003080 - 0000309F] Intel(R) N10/ICH7 Family USB Universal Host Controller - 27C8
-  [000030A0 - 000030AF] Intel(R) N10/ICH7 Family Serial ATA Storage Controller - 27C0
-  [000030B0 - 000030B7] Intel(R) N10/ICH7 Family Serial ATA Storage Controller - 27C0
-  [000030B8 - 000030BF] Intel(R) N10/ICH7 Family Serial ATA Storage Controller - 27C0
-  [000030C0 - 000030C7] Intel(R) Graphics Media Accelerator 3600 Series
-  [000030C8 - 000030CB] Intel(R) N10/ICH7 Family Serial ATA Storage Controller - 27C0
-  [000030CC - 000030CF] Intel(R) N10/ICH7 Family Serial ATA Storage Controller - 27C0
-  [0000EFA0 - 0000EFBF] Intel(R) N10/ICH7 Family SMBus Controller - 27DA
-  [0000FFFF - 0000FFFF] Motherboard resources





















































C.2 <Memory Address Map>





































Memory	
[00000000 - 00000FFF]	Motherboard resources
[00000000 - 00000FFF]	Motherboard resources
[00000000 - 00003FFF]	Motherboard resources
[000A0000 - 000BFFFF]	Intel(R) Graphics Media Accelerator 3600 Series
[000A0000 - 000BFFFF]	PCI bus
[000C0000 - 000DFFFF]	PCI bus
[000E0000 - 000EFFFF]	PCI bus
[000F0000 - 000FFFFFF]	PCI bus
[BF800000 - BFFFFFFF]	PCI bus
[C0000000 - C001FFFF]	Intel(R) 82583V Gigabit Network Connection
[C0000000 - C00FFFFFF]	Intel(R) N10/ICH7 Family PCI Express Root Port - 27D0
[C0000000 - FEBFFFFFF]	PCI bus
[C0020000 - C0023FFF]	Intel(R) 82583V Gigabit Network Connection
[C0100000 - C01FFFFFF]	Intel(R) Graphics Media Accelerator 3600 Series
[C0200000 - C0203FFF]	High Definition Audio Controller
[C0204000 - C02043FF]	Intel(R) N10/ICH7 Family Serial ATA Storage Controller - 27C0
[C0204400 - C02047FF]	Intel(R) N10/ICH7 Family USB2 Enhanced Host Controller - 27CC
[FED00000 - FED003FF]	High precision event timer
[FED1C000 - FED1FFFF]	Motherboard resources
[FED45000 - FED8FFFF]	Motherboard resources
[FF000000 - FFFFFFFF]	Intel(R) 82802 Firmware Hub Device

C.3 <System IRQ Resources>

Interrupt request (IRQ)

	(ISA) 0x00000000 (00)	System timer
	(ISA) 0x00000001 (01)	Standard PS/2 Keyboard
	(ISA) 0x00000003 (03)	Communications Port (COM2)
	(ISA) 0x00000004 (04)	Communications Port (COM1)
	(ISA) 0x00000008 (08)	System CMOS/real time clock
	(ISA) 0x0000000C (12)	PS/2 Compatible Mouse
	(ISA) 0x0000000D (13)	Numeric data processor
	(ISA) 0x00000051 (81)	Microsoft ACPI-Compliant System
	(ISA) 0x00000052 (82)	Microsoft ACPI-Compliant System
	(ISA) 0x00000053 (83)	Microsoft ACPI-Compliant System
	(ISA) 0x00000054 (84)	Microsoft ACPI-Compliant System
	(ISA) 0x00000055 (85)	Microsoft ACPI-Compliant System
	(ISA) 0x00000056 (86)	Microsoft ACPI-Compliant System
	(ISA) 0x00000057 (87)	Microsoft ACPI-Compliant System
	(ISA) 0x00000058 (88)	Microsoft ACPI-Compliant System
	(ISA) 0x00000059 (89)	Microsoft ACPI-Compliant System
	(ISA) 0x0000005A (90)	Microsoft ACPI-Compliant System
	(ISA) 0x0000005B (91)	Microsoft ACPI-Compliant System
	(ISA) 0x0000005C (92)	Microsoft ACPI-Compliant System
	(ISA) 0x0000005D (93)	Microsoft ACPI-Compliant System
	(ISA) 0x0000005E (94)	Microsoft ACPI-Compliant System
	(ISA) 0x0000005F (95)	Microsoft ACPI-Compliant System
	(ISA) 0x00000060 (96)	Microsoft ACPI-Compliant System
	(ISA) 0x00000061 (97)	Microsoft ACPI-Compliant System
	(ISA) 0x00000062 (98)	Microsoft ACPI-Compliant System
	(ISA) 0x00000063 (99)	Microsoft ACPI-Compliant System
	(ISA) 0x00000064 (100)	Microsoft ACPI-Compliant System
	(ISA) 0x00000065 (101)	Microsoft ACPI-Compliant System
	(ISA) 0x00000066 (102)	Microsoft ACPI-Compliant System
	(ISA) 0x00000067 (103)	Microsoft ACPI-Compliant System
	(ISA) 0x00000068 (104)	Microsoft ACPI-Compliant System
	(ISA) 0x00000069 (105)	Microsoft ACPI-Compliant System
	(ISA) 0x0000006A (106)	Microsoft ACPI-Compliant System
	(ISA) 0x0000006B (107)	Microsoft ACPI-Compliant System
	(ISA) 0x0000006C (108)	Microsoft ACPI-Compliant System
	(ISA) 0x0000006D (109)	Microsoft ACPI-Compliant System
	(ISA) 0x0000006E (110)	Microsoft ACPI-Compliant System
	(ISA) 0x0000006F (111)	Microsoft ACPI-Compliant System
	(ISA) 0x00000070 (112)	Microsoft ACPI-Compliant System
	(ISA) 0x00000071 (113)	Microsoft ACPI-Compliant System
	(ISA) 0x00000072 (114)	Microsoft ACPI-Compliant System
	(ISA) 0x00000073 (115)	Microsoft ACPI-Compliant System
	(ISA) 0x00000074 (116)	Microsoft ACPI-Compliant System
	(ISA) 0x00000075 (117)	Microsoft ACPI-Compliant System
	(ISA) 0x00000076 (118)	Microsoft ACPI-Compliant System
	(ISA) 0x00000077 (119)	Microsoft ACPI-Compliant System
	(ISA) 0x00000078 (120)	Microsoft ACPI-Compliant System
	(ISA) 0x00000079 (121)	Microsoft ACPI-Compliant System
	(ISA) 0x0000007A (122)	Microsoft ACPI-Compliant System
	(ISA) 0x0000007B (123)	Microsoft ACPI-Compliant System
	(ISA) 0x0000007C (124)	Microsoft ACPI-Compliant System

	(ISA) 0x0000007D (125)	Microsoft ACPI-Compliant System
	(ISA) 0x0000007E (126)	Microsoft ACPI-Compliant System
	(ISA) 0x0000007F (127)	Microsoft ACPI-Compliant System
	(ISA) 0x00000080 (128)	Microsoft ACPI-Compliant System
	(ISA) 0x00000081 (129)	Microsoft ACPI-Compliant System
	(ISA) 0x00000082 (130)	Microsoft ACPI-Compliant System
	(ISA) 0x00000083 (131)	Microsoft ACPI-Compliant System
	(ISA) 0x00000084 (132)	Microsoft ACPI-Compliant System
	(ISA) 0x00000085 (133)	Microsoft ACPI-Compliant System
	(ISA) 0x00000086 (134)	Microsoft ACPI-Compliant System
	(ISA) 0x00000087 (135)	Microsoft ACPI-Compliant System
	(ISA) 0x00000088 (136)	Microsoft ACPI-Compliant System
	(ISA) 0x00000089 (137)	Microsoft ACPI-Compliant System
	(ISA) 0x0000008A (138)	Microsoft ACPI-Compliant System
	(ISA) 0x0000008B (139)	Microsoft ACPI-Compliant System
	(ISA) 0x0000008C (140)	Microsoft ACPI-Compliant System
	(ISA) 0x0000008D (141)	Microsoft ACPI-Compliant System
	(ISA) 0x0000008E (142)	Microsoft ACPI-Compliant System
	(ISA) 0x0000008F (143)	Microsoft ACPI-Compliant System
	(ISA) 0x00000090 (144)	Microsoft ACPI-Compliant System
	(ISA) 0x00000091 (145)	Microsoft ACPI-Compliant System
	(ISA) 0x00000092 (146)	Microsoft ACPI-Compliant System
	(ISA) 0x00000093 (147)	Microsoft ACPI-Compliant System
	(ISA) 0x00000094 (148)	Microsoft ACPI-Compliant System
	(ISA) 0x00000095 (149)	Microsoft ACPI-Compliant System
	(ISA) 0x00000096 (150)	Microsoft ACPI-Compliant System
	(ISA) 0x00000097 (151)	Microsoft ACPI-Compliant System
	(ISA) 0x00000098 (152)	Microsoft ACPI-Compliant System
	(ISA) 0x00000099 (153)	Microsoft ACPI-Compliant System
	(ISA) 0x0000009A (154)	Microsoft ACPI-Compliant System
	(ISA) 0x0000009B (155)	Microsoft ACPI-Compliant System
	(ISA) 0x0000009C (156)	Microsoft ACPI-Compliant System
	(ISA) 0x0000009D (157)	Microsoft ACPI-Compliant System
	(ISA) 0x0000009E (158)	Microsoft ACPI-Compliant System
	(ISA) 0x0000009F (159)	Microsoft ACPI-Compliant System
	(ISA) 0x000000A0 (160)	Microsoft ACPI-Compliant System
	(ISA) 0x000000A1 (161)	Microsoft ACPI-Compliant System
	(ISA) 0x000000A2 (162)	Microsoft ACPI-Compliant System
	(ISA) 0x000000A3 (163)	Microsoft ACPI-Compliant System
	(ISA) 0x000000A4 (164)	Microsoft ACPI-Compliant System
	(ISA) 0x000000A5 (165)	Microsoft ACPI-Compliant System
	(ISA) 0x000000A6 (166)	Microsoft ACPI-Compliant System
	(ISA) 0x000000A7 (167)	Microsoft ACPI-Compliant System
	(ISA) 0x000000A8 (168)	Microsoft ACPI-Compliant System
	(ISA) 0x000000A9 (169)	Microsoft ACPI-Compliant System
	(ISA) 0x000000AA (170)	Microsoft ACPI-Compliant System
	(ISA) 0x000000AB (171)	Microsoft ACPI-Compliant System
	(ISA) 0x000000AC (172)	Microsoft ACPI-Compliant System
	(ISA) 0x000000AD (173)	Microsoft ACPI-Compliant System
	(ISA) 0x000000AE (174)	Microsoft ACPI-Compliant System
	(ISA) 0x000000AF (175)	Microsoft ACPI-Compliant System
	(ISA) 0x000000B0 (176)	Microsoft ACPI-Compliant System

	(ISA) 0x000000A9 (169)	Microsoft ACPI-Compliant System
	(ISA) 0x000000AA (170)	Microsoft ACPI-Compliant System
	(ISA) 0x000000AB (171)	Microsoft ACPI-Compliant System
	(ISA) 0x000000AC (172)	Microsoft ACPI-Compliant System
	(ISA) 0x000000AD (173)	Microsoft ACPI-Compliant System
	(ISA) 0x000000AE (174)	Microsoft ACPI-Compliant System
	(ISA) 0x000000AF (175)	Microsoft ACPI-Compliant System
	(ISA) 0x000000B0 (176)	Microsoft ACPI-Compliant System
	(ISA) 0x000000B1 (177)	Microsoft ACPI-Compliant System
	(ISA) 0x000000B2 (178)	Microsoft ACPI-Compliant System
	(ISA) 0x000000B3 (179)	Microsoft ACPI-Compliant System
	(ISA) 0x000000B4 (180)	Microsoft ACPI-Compliant System
	(ISA) 0x000000B5 (181)	Microsoft ACPI-Compliant System
	(ISA) 0x000000B6 (182)	Microsoft ACPI-Compliant System
	(ISA) 0x000000B7 (183)	Microsoft ACPI-Compliant System
	(ISA) 0x000000B8 (184)	Microsoft ACPI-Compliant System
	(ISA) 0x000000B9 (185)	Microsoft ACPI-Compliant System
	(ISA) 0x000000BA (186)	Microsoft ACPI-Compliant System
	(ISA) 0x000000BB (187)	Microsoft ACPI-Compliant System
	(ISA) 0x000000BC (188)	Microsoft ACPI-Compliant System
	(ISA) 0x000000BD (189)	Microsoft ACPI-Compliant System
	(ISA) 0x000000BE (190)	Microsoft ACPI-Compliant System
	(PCI) 0x0000000A (10)	Intel(R) N10/ICH7 Family SMBus Controller - 27DA
	(PCI) 0x00000010 (16)	Intel(R) N10/ICH7 Family PCI Express Root Port - 27D0
	(PCI) 0x00000010 (16)	Intel(R) N10/ICH7 Family USB Universal Host Controller - 27CB
	(PCI) 0x00000011 (17)	Intel(R) N10/ICH7 Family PCI Express Root Port - 27D2
	(PCI) 0x00000012 (18)	Intel(R) N10/ICH7 Family PCI Express Root Port - 27D4
	(PCI) 0x00000012 (18)	Intel(R) N10/ICH7 Family USB Universal Host Controller - 27CA
	(PCI) 0x00000013 (19)	Intel(R) N10/ICH7 Family PCI Express Root Port - 27D6
	(PCI) 0x00000013 (19)	Intel(R) N10/ICH7 Family Serial ATA Storage Controller - 27C0
	(PCI) 0x00000013 (19)	Intel(R) N10/ICH7 Family USB Universal Host Controller - 27C9
	(PCI) 0x00000016 (22)	High Definition Audio Controller
	(PCI) 0x00000017 (23)	Intel(R) N10/ICH7 Family USB Universal Host Controller - 27C8
	(PCI) 0x00000017 (23)	Intel(R) N10/ICH7 Family USB2 Enhanced Host Controller - 27CC
	(PCI) 0xFFFFFFFF (-3)	Intel(R) 82583V Gigabit Network Connection
	(PCI) 0xFFFFFFFF (-2)	Intel(R) Graphics Media Accelerator 3600 Series

Appendix D <Watch Dog timer Setting>

The watchdog timer makes the system auto-reset while it stops to work for a period. The integrated watchdog timer can be setup as system reset mode by program.

Timeout Value Range

- 1 to 255
- Second or Minute

Program Sample

Watchdog timer setup as system reset with 5 second of timeout

O 2E 87	
O 2E 87	
O 2E 07	
O 2F 08	Logical Device 8
O 2E 30	
O 2F 01	Activate
O 2E F5	
O 2F 02	Set as Second*
O 2E F6	
O 2F 05	Set as 5

* Minute: bit 3 = 1; Second: bit 3 = 0

You can select Timer setting in the BIOS, after setting the time options, the system will reset according to the period of your selection.

This Page is Left for Blank)

Contact Information

Any advice or comment about our products and service, or anything we can help you please don't hesitate to contact with us. We will do our best to support you for your products, projects and business.

Taiwan Commate Computer Inc.

Address	19F., No.94, Sec. 1, Xintai 5th Rd., Xizhi Dist., New Taipei City 22102, Taiwan
TEL	+886-2-26963909
FAX	+886-2-26963911
Website	http://www.commell.com.tw
E-Mail	info@commell.com.tw (General Information) tech@commell.com.tw (Technical Support)
Facebook	https://www.facebook.com/pages/Taiwan-Commate-Computer-Inc/547993955271899
Twitter	https://twitter.com/Taiwan_Commate

Commell is our trademark of industrial PC division