



**TANCO AUTOWRAP
404 EH MINI BALE WRAPPER
OPERATORS HANDBOOK
WD03-404EH**

MODELS:

- **404 EH – Trailed with load arm and Automatic Control**
- **404 M – Linkage mounted with cut and start, tipping facility and manual control**
- **404 S -- Linkage mounted without cut and start or tipping facility**



GUARANTEE

Subject to hereunder provided, the sellers undertake to correct either by repair or at their election by replacement any defect of material or workmanship which occurs in any of its goods within twelve months after delivery of such goods to first user, with the exception of contractors or commercial users when warranty period is six months.

In respect of Autowraps the warranty period is for 12 months or 8000 bales, whichever occurs first.

The term goods when used in this document means the article or articles described in invoices as sold by the sellers but does not include equipment or proprietary parts or accessories not manufactured by the sellers. The sellers, however, undertake to pass on so far as they legally can to the first user the benefit of any warranty given to the sellers by the suppliers of such equipment, parts or accessories.

This understanding shall not apply to:-

- (a) Any goods that have been sold by the first user.
- (b) Any goods which have been injured by unfair wear and tear, neglect or improper use.
- (c) Any goods the identification marks of which have been altered or removed.
- (d) Any goods that have not received the basic normal maintenance such as tightening of bolts, nuts, tines, hose connections and fittings and normal lubrication with the recommended lubricant.
- (e) The use of any product on tractors exceeding the recommended horsepower.
- (f) Any goods that have been altered or repaired other than on instruction or with the written approval of the seller or to which any part not manufactured or having written approval by the sellers have been fixed.
- (g) Any second-hand goods or parts thereof.

Any allegedly defective part or parts returned to the seller must be sent carriage paid. No claim for repair or replacement will be entertained unless upon discovery of the alleged defect written notification is sent to the Sellers giving, at the same time, the name of the Buyer from whom the goods were purchased and the date of purchase, together with the full details of the alleged defect and the circumstances involved, also the serial number of the machine etc.

The sellers shall be under no liability to their Buyers and first or subsequent users of their goods or to any other person or persons for loss or damage howsoever arising in respect of either personal injuries or for arising out of, or in any other way connected with or arising from the manufacture sale, handling, repair, maintenance, replacement or use of its goods or the failure or malfunction of any of its goods.

Representation and/or warranties made by any persons (including Buyers and employees and other representatives of the Seller) which are inconsistent or conflicting with these conditions are not binding upon the sellers unless given in writing and signed by a director of sales.

CLAIMS

If you wish to make a claim under the guarantee:

- 1: Immediately, stop using the machine.
- 2: Photocopy and fill out the warranty claim form attached to the back of this manual. List the details of the machine, its serial number and the part number of the damaged part.
- 3: Consult with your Tanco dealer (supplier) and have him forward your claim and the damaged item to Tanco.



USER'S MANUAL

MINI WRAP 404 EH

CHAP. CONTENTS	PAGE
1.0 INTRODUCTION	4-5
2.0 SAFETY PRECAUTIONS	6-7
3.0 GENERAL INFORMATION ON BALE WRAPPING	8-9
4.0 SETTING UP / MOUNTING OF THE MACHINE	10
5.0 MOUNTING OF PLASTIC FILM	11-12
6.0 ADJUSTMENTS/OPERATING	13
7.0 OPERATING INSTRUCTION	14
8.0 INSTRUCTIONS CONTROL BOX	15-24
9.0 PERIODIC MAINTENANCE	23
10.0 CHECK POINTS BEFORE TROUBLESHOOTING	24
11.0 TROUBLE SHOOTING	25
12.0 ELECTRIC, HYDRAULIC CHART	26
13.0 OPEN/CLOSED CENTRE CONVERSION	28
14.0 WARRENTY CLAIM FORM	29
14.0 DECLARATION OF CONFORMITY	30

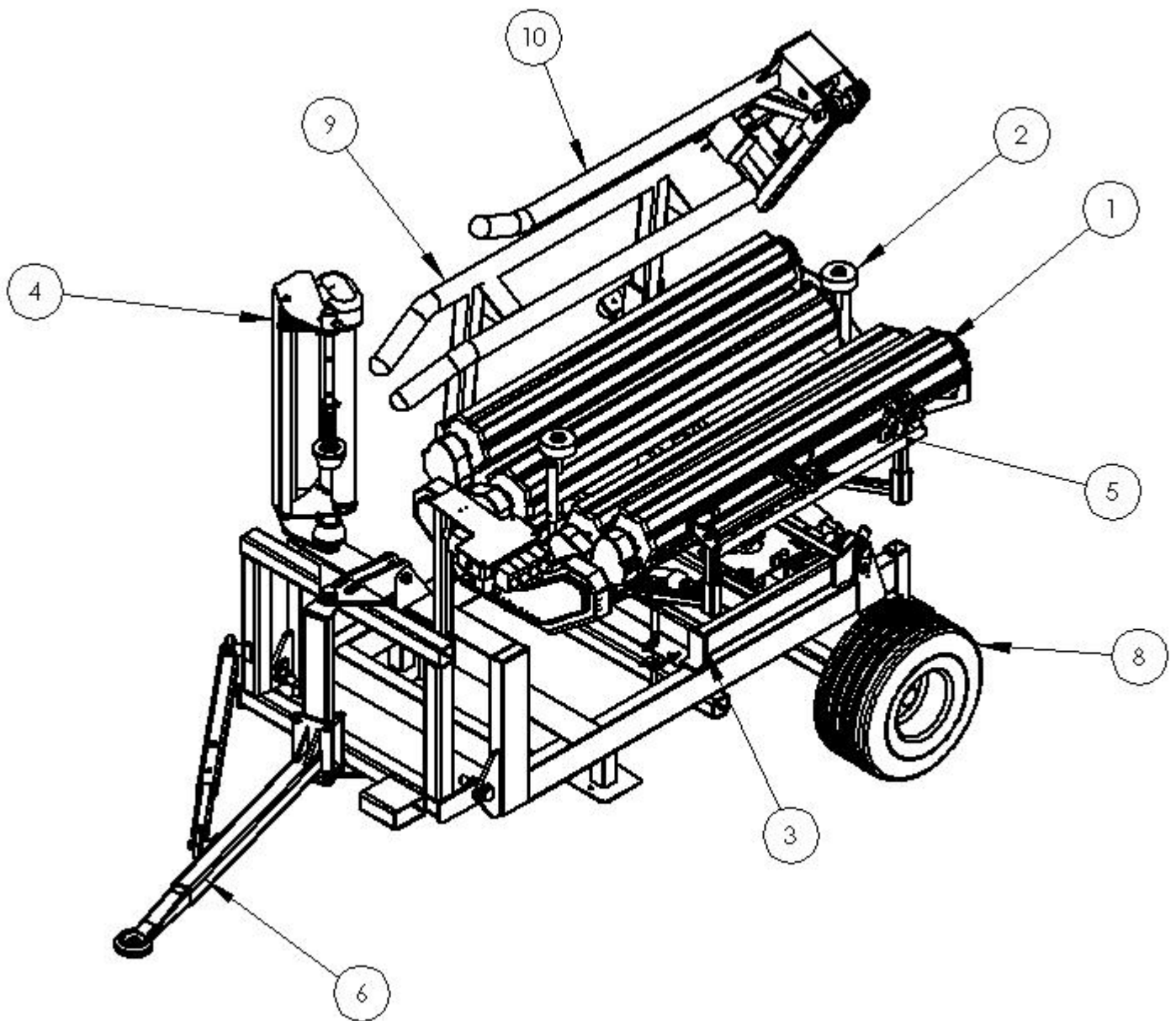

Fig 1.- 404 EH Model

1. Roller
2. End roller
3. Tilt Frame
4. Film Dispenser
5. Cutter
6. Drawbar
7. Jockey wheel
8. Wheel
9. Load arm
10. Squeeze arm



1.0 INTRODUCTION.

TANCO AUTOWRAP Ltd. congratulates you with the choice of MINI WRAP bale wrapping machine. We are certain you will be satisfied with the machine, and that you will have the pleasure of your investment for many years.

MINI WRAP 404 EH is hydraulically driven by the tractors hydraulic system, and is easy to operate with the RDS control box.

The MINI WRAP 404 EH is designed to be a simple and effective bale wrapping machine square bales.

MINI WRAP 404EH is estimated for wrapping bales of grass, hay or straw, it can handle bales from 35cm x 45cm up to 50cm x 50cm. The bales must have a weight of at least 35kg.

This manual is meant to explain how MINI WRAP is prepared, mounted, used and how it works, and shall together with the spare part's list be a reference for maintenance and troubleshooting. So take good care of the books, they are a part of the machine.

Read carefully through this manual, and specially chapter 2.0, safety instructions, before starting the machine, and follow the instructions thoroughly. If problems should occur, please contact your MINIWRAP dealer. Ask your dealer for advice before you make the problem worse than it is. See also chapter 13.0, Warranty terms.

Technical Specifications	MINI WRAP 404 EH
Height in working position	930 mm
Width	1640 mm
Length	3200 mm
Weight	625 kg
Turntable speed, recommended	22 rev, per minute
Turntable speed, max.	27 rev, per minute
Bale size, max.	500 x 500 x 1150 mm
Bale weight, min	35kg
Pre-stretcher	500 mm
Hydraulic connection	I single spool outlet + free return
Oil pressure / amount, mm.	100 bar / 15 liter per minute
Oil amount, max.	30 liter per minute
Counter pressure, max.	10 bar

TANCO AUTOWRAP Ltd can change the construction and/or technical specifications without warning and without rights to changes on already delivered products.

© Copyright. All rights reserved. Any copying and reproduction of this manual is not permitted without permission from TANCO AUTOWRAP Ltd

2.0 SAFETY PRECAUTIONS.

TANCO AUTOWRAP Ltd does not take the responsibility for damages that may occur on machine, persons or other equipment, because of the machine NOT being used as described in this manual, or because of the safety precautions NOT being followed.

2.1 SAFETY EQUIPMENT.

Before using the machine, make sure that all guards and covers are securely fitted. The machine must not be operated if a function does not work as described later in this manual. (See chapter 2.5).

2.2 BECOME FAMILIAR WITH THE OPERATIONS OF THE MACHINE.

If you are unsure how to operate the machine properly, either use of or maintenance to your Mini Wrap, please contact your Mini Wrap dealer.

2.3 ADJUSTMENTS' / MAINTENANCE.

Turn off the tractor and discharge the oil pressure before performing any adjustment or maintenance on the machine. Remember that a well-maintained machine is a safe machine.

2.4 IMPORTANT!

**ALWAYS MAKE SURE THAT NOBODY IS INSIDE
THE MACHINE'S WORKING AREA WHEN IT'S IN USE.
SAFETY DISTANCE IS 5 METRES**

**THE MACHINE MUST NEVER BE OPERATED BY PERSONS WHOM DOES NOT KNOW
ENOUGH ABOUT HOW TO SAFELY OPERATE THE MACHINE, OR BY PERSONS
UNDER 16 YEARS OF AGE.**

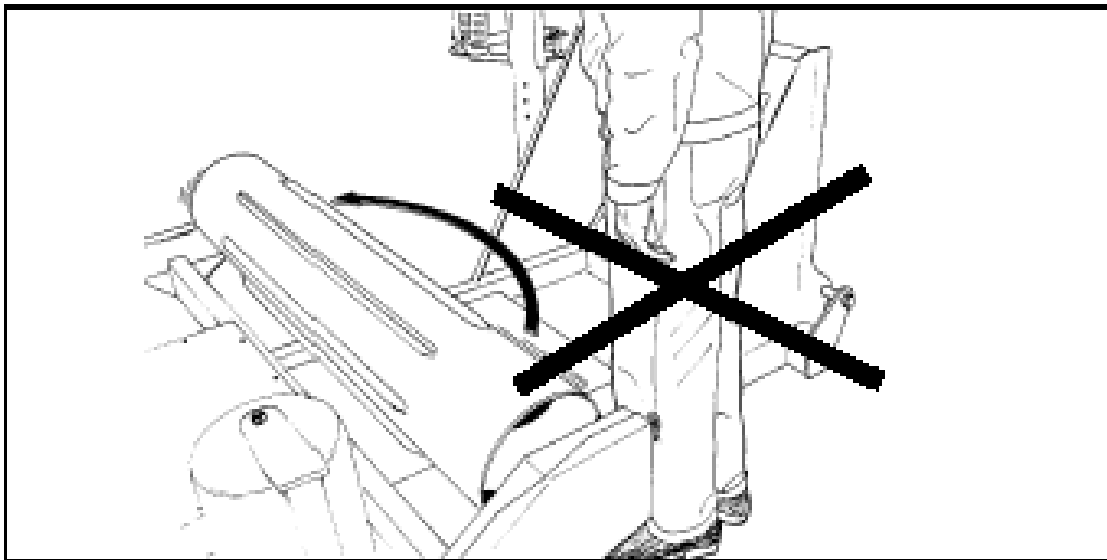

Fig. 2-1

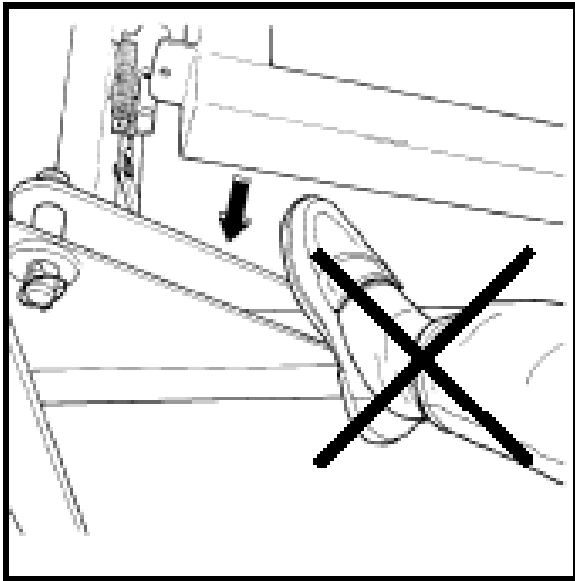

Fig. 2-2

2.5 DANGEROUS AREAS.

TANCO AUTOWRAP Ltd has given the safety to the operator the highest priority, but it is still impossible to secure oneself of every danger area on the machine. Therefore we will now go through some of the dangers that can occur when using the Mini Wrap bale wrapper.

1. Be especially aware of the rotating turntable. There is a danger of being squeezed between the turntable and the main frame.
2. When the wrapping of a bale is complete and tipped off the machine, the turntable has to be tipped back before wrapping next bale. When the middle frame with turntable is lowered, there is a squeeze danger between the middle frame and the main frame on both sides and in the back end of the machine. Keep therefore fingers and feet in safe distance. (Fig. 2-2).
3. When tipping the turntable, the bale will roll free off the machine. Staying behind the machine can cause danger for “overrunning” by the bale when it rolls off. Make therefore sure that nobody is behind the machine when unloading.

2.6 WHILE WRAPPING.

Please keep your hands on the controller during the wrapping process. The machine is to stand horizontally while the wrapping takes place. Make sure that nobody comes into the working area of the machine,

2.7 TRANSPORTING.

When transported on a public road there are certain safety measures that must be taken:

1. Make sure that the lift arm is in a raised position.
2. Make sure that the locking bolts on lift arm and the fall damper are mounted.
3. Make sure that the machine does not cover the tractors' lights. If necessary, mount extra lights.



3.0 GENERAL INFORMATION ON BALE WRAPPING.

3.1 THE PRINCIPLE.

The advantages of round/square bale silage are many, and include fewer feed units, a flexible harvesting system, large capacity and the possibility of selling feed units.

In principle, the same fermentation processes occur whether the fodder is placed in a silo or pressed into bales and packed in plastic, i.e. lactic acid fermentation in anaerobic conditions. The oxygen in the bale must be exhausted before fermentation begins.

The grass should be dried to approximately 30-40% solid content. The solid content can be determined by twisting the grass by hand. If drops of liquid are forced out of the grass, the solid content is less than 25%. Low solid content, (wet grass), can lead to increased butyric acid fermentation if preservatives are not added to the grass. If the solid content is too high, (over 50%), normal fermentation will not take place and there will be enough oxygen in the bale to produce mould fungus.

3.2 THE BALER.

It is vital that the baler produces compact, well-formed bales, as misshapen bales can be difficult to wrap. Wrapping will also often take longer, thereby increasing the amount of plastic used.

3.3 TYPES OF PLASTIC.

A good type of plastic with good adhesive properties, and which is recommended for bale wrapping, must be used. The thickness of the plastic film should be at least 25 micron. (25/1,000 mm). In order that the plastic tightens sufficiently around the bale, it is stretched before being wrapped, so it is somewhat thinner when it is put on the bale. With short-term storage, (up to eight weeks), it is recommended that bales have a minimum of four layers of plastic at the thinnest points, with at least 52-53% overlap.

For long-term storage, or when the grass is wet when it is wrapped, the bale should have 6 layers, and the same amount of overlap. If thinner plastic is used, more layers should be applied. If it is very hot the plastic will be stretched further, and more layers should be applied. It is better to have slightly too much than too little plastic on the bale.

From experience, light plastic produces slightly lower temperatures within the bale, and tends to improve feed quality.

3.4 STORAGE LOCATION.

Care should be taken in finding a suitable location for the storage of bales. The storage location should preferably be prepared before the bales are laid out. An elevation close to well-drained roads is recommended. If the wrapped bales are simply placed on stubble there is a danger of the plastic being pierced. A tarpaulin or a thin layer of sand should therefore be laid where the bales are to be stored over the winter.

Bales should be stored in the shade as far as possible. This reduces the danger of air leakage in the bales. A bale which is stored in sunlight and which therefore undergoes greater swings in temperature "pumps in" a great deal of air in comparison to a bale which is stored in the shade. According to ~'Teknik for Lantbruket" [Technology for Agriculture] in Sweden, a bale which is stored in the shade has only 40% of the air leakage of a bale which is stored in sunlight.

3.5 STACKING / PROTECTION.

If bales are hard and well formed, they can be stacked vertically, but loose and misshapen bales with low solid content should not be stacked higher than one layer, as this could easily cause deformity and the danger of runoff will be increased.

Bales can also be stored on their sides. The layer of plastic is thicker here, providing greater protection against piercing.

Bales should be covered with a tarpaulin or a fine-mesh net to protect against birds and small



rodents. If the plastic is pierced, it must be sealed with weatherproof, hard-wearing tape, preferably under the outermost layer of plastic. Ensure that the hole is adequately sealed.

3.6 The best wrapping results are obtained by...

1. ...Harvesting the grass early.
2. ...Drying it out to 30-40% solid content. If there is a danger of rain, bale and wrap the grass anyway.
3. ...Taking care not to mix any earth in with the grass.
4. ...Using a baler which produces even, firm bales.
5. ...Wrapping the bales soon after baling, never later than two hours afterwards.
6. ...Using a good type of plastic and six layers of plastic. This removes the need to use preservatives.
7. ...Storing bales in the shade to reduce the danger of air leakage.



4.0 SETTING UP / MOUNTING OF THE MACHINE.

4.1 Mounting the Drawbar.

The Drawbar should be positioned such that the machine is parallel with the ground when it is connected to the tractor.

4.2 Mount the loading arm and adjust the width on the lift arm in accordance with the bales diameter. Adjust the loading arms end stopper so that the bale will be placed in the middle of the table when loading.

4.3 Mount the Film Dispenser.

Adjust the height on the Dispenser so that the middle of the plastic meets with the bale's center.

4.4 Mount the safety arm to the Chassis

4.5 Lubricate the machine.

4.6 Check that all the bolts and nuts are tightened, specially the wheel bolts.

4.7 Remove the safety bolts used under transportation from the loading arm, insert the safety bolts into the parking holes.

4.8 Connect the machine to the tractors rear trailer hitch.

4.9 HYDRAULIC CONNECTION.

The hydraulic hoses between machine and tractor are equipped with 1/2' ISO male quick-couplers. Discharge the oil pressure before you connect the oil hoses. Use the tractors' hydraulic lever. Connect the hoses so that the turntable rotates counterclockwise.

To make sure that the bale wrapper works properly, the tractors' oil pressure has to be at least 100 bar. If you are unsure of what oil pressure the tractor gives, or what oil pressure the bale wrapper receives, please contact your machinery dealer.

NB! When connected to a tractor with closed center (e.g. JOHN DEERE) a special, closed centers, plug must be fitted to the valve to prevent the oil over heating (consult your dealer and parts book and see chapter 13.0).

4.10 CHECK LIST.

Before using the machine it is recommended to follow this check list:

1. Make it a habit to discharge the oil-pressure before connection or disconnection of the hydraulic hoses. (Use the tractors hydraulic control lever).
2. Hose with BLUE CAP = RETURN OIL.
3. Hose with RED CAP = PRESSURE.
4. Tie up loose hoses so that no squeeze damages occur.
5. Start the tractor and try out the functions. (It should rotate counterclockwise).
6. Check all connections, hoses and couplings. If there is any oil-leakage, it should be rectified immediately.

Your MINI WRAP bale wrapper has been tested in practical operation in approx. 2 hours at the factory.

5.0 MOUNTING OF THE PLASTIC FILM

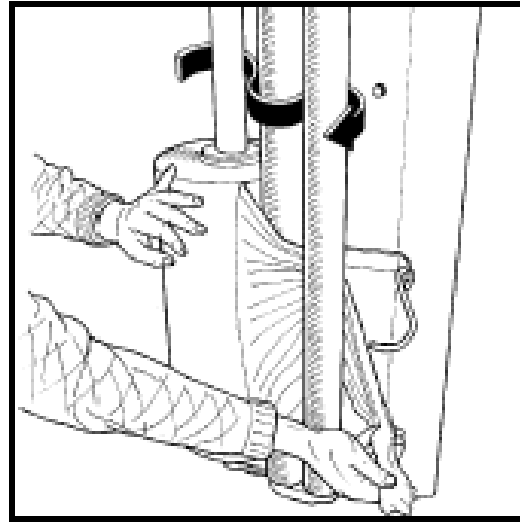
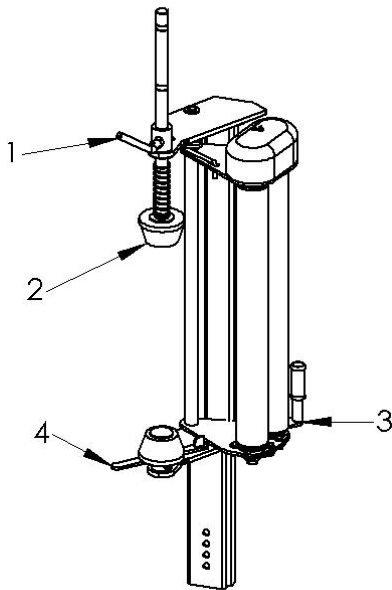

Fig. 5-2

- 5.1 When loading a plastic roll, first push back the Stretch rollers (3) until held in position by locking catch (4). Then loosen locking bolt (1) and raise top cone (2) and lock in raised position.
- 5.2 Place a roll of film on to the Dispenser. Drop the top cone down and apply pressure to the top of the shaft to compress the spring and allow the locking bolt to close one of the grooves in the shaft.
- 5.3 Pull the film between the rollers on the pre-stretcher in the direction of the arrow. (See fig. 5-2). (See also the sticker on the dispenser).
- 5.4 Release the locking catch and allow the rollers to lie against the roll of film
- 5.4 Pull out the film and tie it to the bale.

5.5 HEIGHT ADJUSTMENT OF DISPENSER/ PLASTIC FILM.

It is important that the plastic film is applied to the center of the bale, and therefore it can be necessary to adjust the height of the Dispenser. The Dispenser may be adjusted to different heights. Disconnect the locking bolt, and adjust the dispenser so that the plastic hits in the middle of the bale. Replace the locking bolt and the splint.

The Tanco film Dispenser supplied with all 404 machine is capable of using several different sizes of film rolls. 500 mm, 360 mm and 250 mm plastic film can all be used but care must be taken that the correct level of overlap is used as you need turntable roller speeds for different films. (see also 6.4 Overlap)

5.6 Tanco Dual Stretch Dispenser

Some Tanco Autowrap machines can optionally be fitted with a patented dual stretch gear system.

This system enables a quick change of stretch levels on the Film Dispenser.

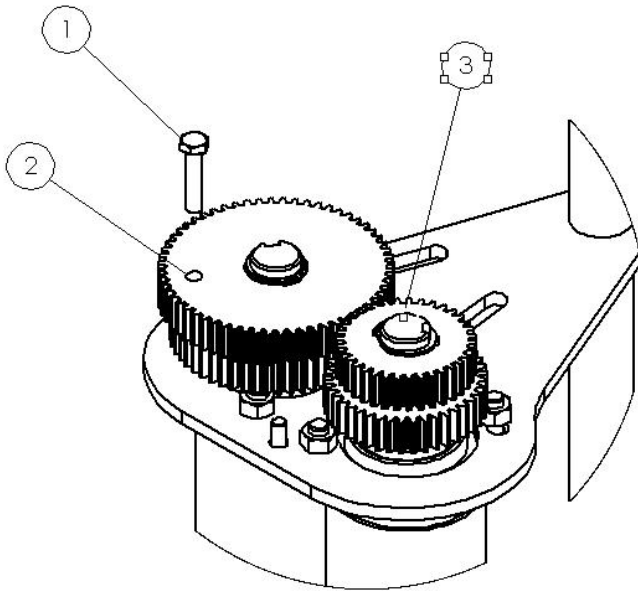

If the bolt (1) is fitted in position 2, the top set of gears provide the stretch (55%).

By removing the bolt from position 2 and fitting it in position 3, the bottom set of gears become the stretch gears giving 32% (for prestretched film)

Tanco Dispenser Gear Combinations

Inner Gear	Outer Gear	% Stretch
60 Tooth	35 Tooth	70%
58 Tooth	37 Tooth	55%
54 Tooth	41 Tooth	32%

6.0 ADJUSTMENT / OPERATING.

6.1 SUPPORT ROLLERS.

Place the bale you want to wrap on top of the rollers. Move the support rollers as tight to the bale



as possible. Make sure that the bale is in center of the rollers.

6.2 HEIGHT ADJUSTMENT OF DISPENSER.

The Dispenser can be placed in different positions. Disconnect the locking bolt, and adjust the pre-stretcher so that the plastic hits in the middle of the bale. Replace the locking bolt and the splint.

6.3 Operating the RDS control box

See chapter 8

6.4 REVOLUTION SPEED OF TURNTABLE.

Start the machine by operating the lever inside the tractor. All 404's are equipped with an adjustable valve on the outlet from the main valve block to the motor. Screw in to reduce turntable speed. Adjust this until the turntable speed is approx. 22 revolutions per minute (Just below 3 seconds per revolution) and lock the knob in position by tightening the allen-headed screw in it.

6.5 OVERLAP.

To control the overlap, stop the machine after a few turns. Use a marker to mark a line on the middle of the film wrapped on the bale. By the next turn this line should just be covered. It is now possible to use either the 500mm, 360mm or 250mm film on the MINI WRAP 404EH. The machine is generally delivered set up for use with the 360mm film. Tanco recommend this size of film for best results.

If using 250mm or 500 mm film, a special set of sprockets need to be fitted to the turntable (inside the large chain guard) to maintain correct bale indexing speed. See parts books or contact your dealer for advice. The chains from the turntable's main shaft must be lengthened or shortened as required to ensure correct chain tension. Note that these are twin sprockets. Fit chain to larger sprocket for 250 mm film and on smaller for 500 mm film.



7.0 OPERATING INSTRUCTION.

We shall now go through a complete wrapping process, from loading to storage place, and explain the practical use of the MINI WRAP 404.

7.1 LOADING.

On the 404 EH machine the standard load-arm enables easy loading of the bale. The Bale can be loaded manually by pressing and holding the load arm up button or automatically (if this option is enabled in the software) by pressing autostart button. Please note that factory set-up does not have auto-load facility enabled.

7.2 HEIGHT ADJUSTMENT OF DISPENSER.

The height of the pre-stretcher has to be adjusted so that the plastic film is always hitting the middle of the bale. (See more about this in chapter 5.5 and 6.2).

7.3 TIPS ON WRAPPING SQUARE BALES.

The MINI WRAP 404EH is assembled for delivery with the rollers in the outer position. If the bales to be wrapped are in some degree smaller than mean measure then the rollers must be moved. (Optimally the film should meet the bale being wrapped in the middle.) The chain cover must be removed, and the Rocking roller assembly moved either in or out. The chain length must be adjusted so ensure the chain-tension is tightened before finally the bolts are replaced. Remember that a hard and well packed bale will give the best result when wrapping.

7.4 START.

Remember that the plastic film end must be tied to the bale. This is normally only necessary on the first bale. Operate the hydraulic lever carefully to make a gently start. To quick start can rip off the plastic film, and then it has to be tied again.

7.5 OVERLAP.

Control that the overlap is correct. If not, see chapter 6.4.

7.6 HOW MANY LAYERS OF PLASTIC FILM?

When the bale is completely covered with film, read the counter that displays the number of revolutions done by the turntable. If you don't have a counter, you have to count the revolutions yourself, (or you can measure the time it takes). This number has to be multiplied by 2 or 3, depending on how many layers of film you want to have.

- * 4 layers multiply by 2.
- * 6 layers multiply by 3.

7.7 STOP / UNLOADING.

When the wrapping is complete, ensure the turntable is in the tip position (i.e at right angle to the chassis). To commence the tip off sequence press the auto-tip button on the controller. The table will tip up and cut the film and come back down automatically

7.8 NEW BALE.

The turntable automatically returns to load position after tipping down and the cycle can be resumed.



8.0 404EH CONTROL BOX

Service and Technical Support

PLEASE CONTACT YOUR NEAREST TANCO DEALER OR TANCO

Tanco Autowrap Ltd

Bagenalstown

Co. Carlow

Ireland

Tel: +353 (0)59 9721336

Fax: +353 (0)59 9721737

e-mail: info@tanco.ie

web: www.tanco.ie

Contents

8.1.	INTRODUCTION	15
8.1.1	IMPORTANT SAFETY INFORMATION!	15
8.1.2	Main operating Functions and Display	15
8.2	OPERATION	16
8.2.1	Operation in Automatic mode	17
8.2.2	Manually interrupting an automatic wrapping cycle	17
8.2.3	Manual options in Automatic mode	17
8.2.4	Operation in Manual mode	17
8.2.5	The Display Menu	18
8.2.6	Selecting a Store Total	19
8.2.7	Resetting a Store Total to Zero	19
8.2.8	Setting the Number of Wraps	19
8.3	OPERATOR SETUP MENU	20

8.1. Introduction

The Tanco Autowrap Bale Wrap Controller enables the operator to monitor and control the operation of the bale wrapper at any stage of the wrapping cycle. The controller is designed for models: 280ARC, 404EH, 580A, and 1080A table-type wrappers.

There are 2 main operating modes – Automatic and Manual. The automatic mode permits ‘one-touch wrapping’ to ease the workload on the operator. In addition to the standard auto-wrap cycle where the bale load arm is operated manually, for the 580A and 1080A wrappers, bale loading and unloading can be incorporated into the standard auto-wrap cycle (the ‘AUTOLOAD’ option).

The controller is fully programmable to optimise wrapping performance. Bale counts are automatically logged in any one of 10 selectable memory stores, in addition to a grand total memory store.

8.1.1



- Please read and understand the instructions for using this controller before operating the machine.
- This controller is fitted with a pushbutton type On/Off Emergency Stop switch. Always ensure the controller is switched OFF via this switch before attempting any adjustment or maintenance to the machine.
- The machine is fitted with a safety beacon which is automatically activated when a loading, wrapping or tipping operation is initiated via the controller. If the beacon is off, do not assume it is safe to move into the proximity of the machine unless you have confirmed that the controller is switched off and the machine power source is disengaged.
- For safety reasons the 280ARC machine beacon will begin flashing 3 seconds before the automatic cycle commences, after initiating the wrapping cycle via remote control. If the beacon begins flashing when you are in proximity to the machine, then **immediately** stand clear.
- Please follow ALL other safety instructions given in the manufacturers’ Operator Handbook for the machine.

8.1.2 Main operating Functions and Display

The principal instrument features and operating functions are shown in figure 1 below.

Figure

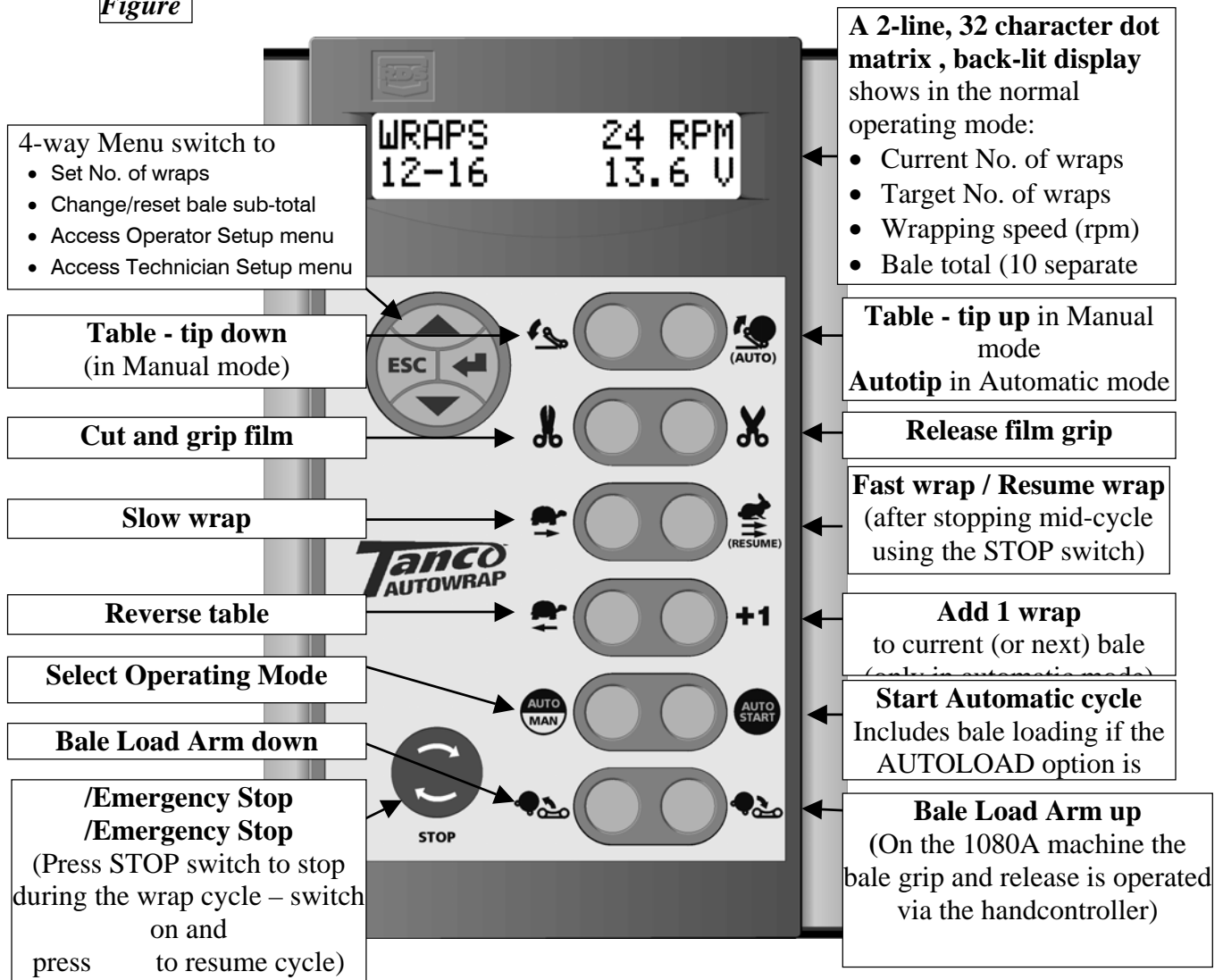

8.2 Operation

8.2.1 Operation in Automatic mode

The controller is generally used in automatic mode. With AUTOLOAD setup (580A / 1080A only), bale loading is incorporated into the automatic cycle for complete 'one touch wrapping'.

'A' on the display indicates that the controller is set in Automatic mode. If not, press  to select.

AUTOLOAD Sequence



Bring the machine up to the bale and press the  switch to commence the automatic sequence – Load, Wrap and Tip Off.

NOTE: The load arm cannot be operated manually to ready the next bale during the wrapping cycle.

Non-AUTOLOAD Sequence

1. Bring the machine up to the bale, then press and hold the  switch to load the bale.

NOTE: On the 1080A machine, the bale grip and release function is operated via the  buttons on the handcontroller.

2. Press and hold the  switch to lower the lift arm.
3. Press the  switch to commence the automatic wrapping cycle. The cycle is completed when the target number of wraps has been reached.
4. Press the  switch to tip the bale off and automatically position the table for loading.

8.2.2



Press the STOP switch. Pressing the  switch after switching the controller back on will resume the auto-wrap cycle from where it stopped.



For safety reasons, if it is necessary to work on the machine (e.g. in the event of a film break or the film running out), then it is strongly recommended that you disengage the machine power source.

8.2.3

With the controller in automatic mode, the following manual functions are possible.

 **SLOW WRAP** (only enabled outside of the wrapping sequence). Press  to resume the normal fast wrap.

 **REVERSE TABLE** (only enabled outside of the wrapping sequence). Press this button to nudge the table backwards to the desired position.

+1 **ADD 1 WRAP** Each time you press this button an additional wrap will be put on the current bale if the wrapping sequence is in progress, or onto the next bale if the automatic cycle has not yet been started. You can add as many wraps as required.

 **LOAD UP /LOAD DOWN** If the 'Autoload' sequence is not selected (580A /1080A only), then you can engage and pick up the next bale while the current bale is being wrapped.

8.2.4 Operation in Manual mode

'M' on the display indicates that the controller is set in manual mode. If not, press  to select.

In manual mode you have total control of every stage of the wrapping cycle.

The software logic determines which manual functions can be activated at any point in the wrapping cycle. Should the operator incorrectly select a function at a certain stage during the wrapping cycle, then that operation will not be performed.



8.2.5 The Display Menu

The Display menu is divided into 3 sections. At the top level are the settings used during the daily work with the machine – i.e. Store totals and No. of Wraps.

The Operator Setup section enables the operator to perform adjustments to the machine operation – e.g. time duration and time delay settings during the automatic cycle.

The Technician Setup menu is not normally accessible to the operator without a PIN access code. Technician Setup is not covered by this manual.

Use the 4-way switch to navigate the menu. Each menu screen indicates which keys to press to make the settings. The instrument will default back to the main operating display after 30 seconds if no other key is pressed

Here is a summary of the display menu;

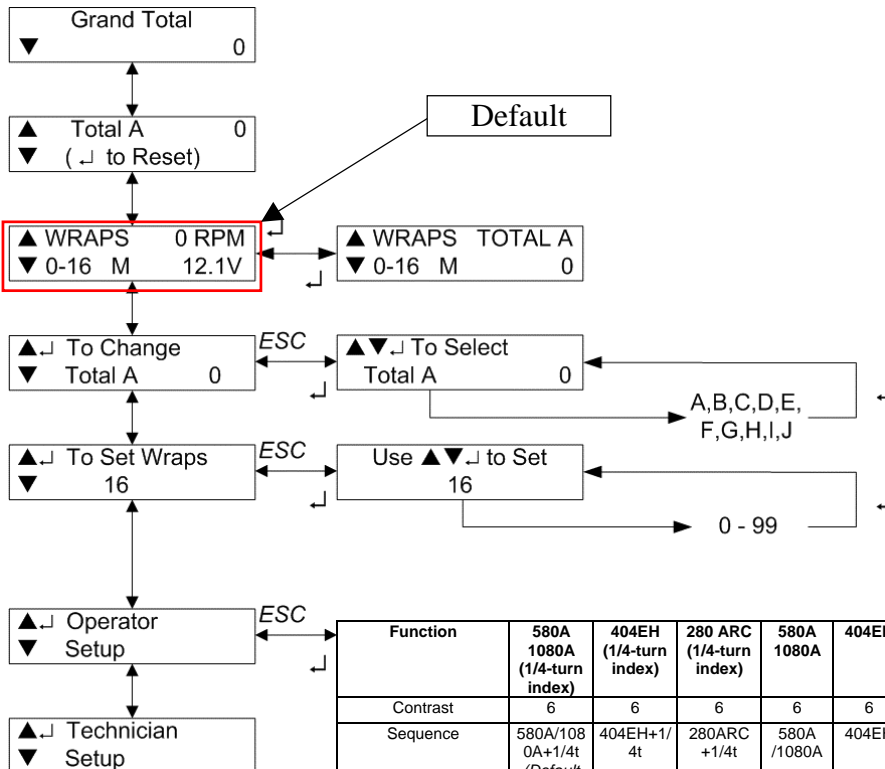

Function	580A 1080A (1/4-turn index)	404EH (1/4-turn index)	280 ARC (1/4-turn index)	580A 1080A	404EH	280 ARC	580A AUTO LOAD	1080A AUTO LOAD	Range	Res.
Contrast	6	6	6	6	6	6	6	6	0-12	1
Sequence	580A/1080A+1/4t (Default Seq.)	404EH+1/4t	280ARC+1/4t	580A/1080A	404EH	280ARC	580A Auto Load	1080A Auto Load		
Film Break	OFF	OFF	OFF	OFF	OFF	OFF	OFF	OFF	ON/OFF	
Cl Ctr Hyd	OFF	OFF	OFF	OFF	OFF	OFF	OFF	OFF	OC/CC	
Squeeze In Duration	0.0	0.0	0.0	0.0	0.0	0.0	0.0	2.0	0-9.9s	0.1s
Load Up Duration	0.0	0.0	0.0	0.0	0.0	0.0	5.0	5.0	0-9.9s	0.1s
Squeeze Out Duration	0.0	0.0	0.0	0.0	0.0	0.0	0.0	3.0	0-9.9s	0.1s
Load Down Pause	0.0	0.0	0.0	0.0	0.0	0.0	0.0	3.0	0-9.9s	0.1s
Tip Up Duration	4.0	4.0	4.0	4.0	4.0	4.0	4.0	4.0	0-9.9s	0.1s
Tip Up to Tip Down Delay	0.3	0.3	0.3	0.3	0.3	0.3	0.3	0.3	0-9.9s	0.1s
Tip Down Duration	4.8	4.8	4.8	4.8	4.8	4.8	4.8	4.8	0-9.9s	0.1s
Delay before Slow Stop	1.2	1.2	1.2	1.2	1.2	1.2	1.2	1.2	0-9.9s	0.1s
Delay to stop after last pulse	0.0	0.0	0.0	0.0	0.0	0.0	0.0	0.0	0-9.9s	0.1s
Language	English	English	English	English	English	English	English	English	E/F/D/N/L/DK	

NOTE: There are additional sequences selectable in the Operator Setup menu but not shown in the table. These sequences are for wrapper models to which this manual does not apply. Please refer to section 3 for further explanation of the Operator Setup functions given in the table above.



8.2.6 Selecting a Store Total

There are 10 individual memory registers labelled 'Store A' to 'Store J' for bale totals. Each time a bale cycle is completed, the currently selected store total and the grand total increments by 1.

The currently selected store is displayed on one of the two screens selectable in the normal operating mode.

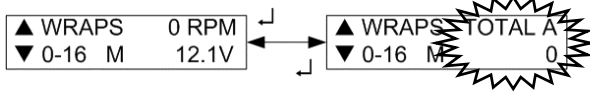

The default setting is Store A. To select a particular store, navigate the display menu using the 4-way switch.

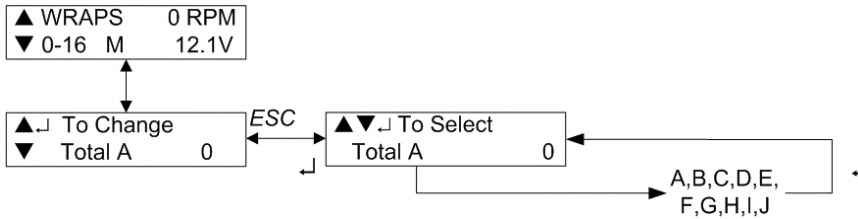

Press the up/down arrow keys to select the store, then press the ENTER key to confirm the selection.

8.2.7 Resetting a Store Total to Zero

Stores A to J can be individually reset to zero at any time. The Grand Total store cannot be reset. First select the store to be zeroed, then navigate the display menu as shown below.

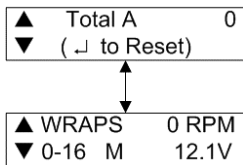

Press the ENTER key to reset.

8.2.8 Setting the Number of Wraps

The default number of wraps is 16. You can set the target number from 0 to 99 by navigating the display menu as shown below.

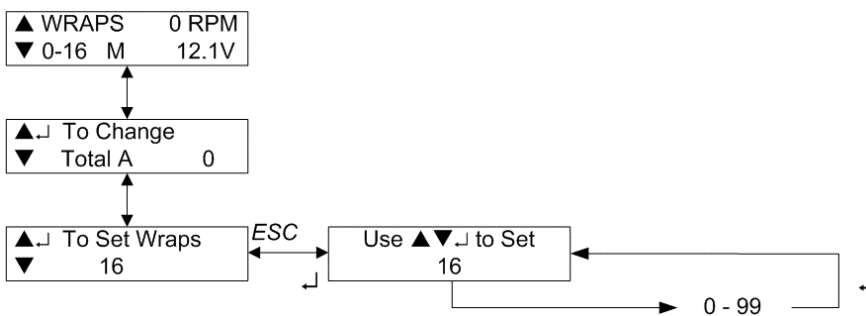



Tanco Autowrap 404 EH Operators manual

8.3 Operator Setup Menu

The default settings for the machine are developed by Tanco for optimal operation of the machine. However, the operator can change certain parameters in the 'Operator Setup' menu to take account of operational conditions.

Parameter	Default	Application	Description
'Film Break'	OFF	N/A	N/A
'CL CTR HYD'	OFF	All	Closed Centre Hydraulic Valve operation: 'OFF' – System pressure valve dumps to tank when no function is operating (for tractors with fixed-output hydraulic system). 'ON' – System pressure valve stays energised (for tractors with demand-sensing hydraulic system).
'Squeeze IN'	2.0s	1510S,1514S, 1514T only	The time period required for the gripper arm to grip the bale sufficiently. Increase setting if the bale grip is insufficient.
'Load UP'	5.0s	580A AUTOLOAD 1080A AUTOLOAD	The time period required for the load arm to reach the point at which the bale transfers onto the table. Adjustment may be required to set the optimum stopping point. If bale transfer is inconsistent, then increase setting to raise the stopping point
'Squeeze OUT'	3.0s	1080A AUTOLOAD only	The time period required for the gripper arm to release the bale. Increase setting if the bale gripper arm does not extend sufficiently.
'Load DOWN Pause'	0.0s 3.0s	All except 1080 AUTOLOAD 1080A AUTOLOAD	The pause duration after the load arm reaches its uppermost position, to allow for the bale to transfer onto the table rollers. Adjustment may be required depending on the size/type of bale. Increase setting if the bale does not transfer in sufficient time.
'Tip UP'	4.0s	All	The time period required for the table to reach the tip off position and offload the bale. Increase setting if the table does not tip far enough.
'Tip Up to DOWN'	0.3s	All	The pause duration after the table has tipped up, to allow for the bale to roll off.
'Tip Down'	4.8s	All	The time period required for the table to return to the horizontal position. Increase setting if the table does not fully return onto the supporting base
'Slow Stop Wait'	1.2s	All	Set the point at which the table slows down towards the end of the wrapping cycle. Adjustment may be required depending on the weight of the bale. Decrease setting if the table overshoots the Stop position.
'Delay to Stop'	0.0s	All	Set to adjust the table Stop position.
Language	English	All	Sets the language for the display prompts.

8.4 404 EH Sensors.

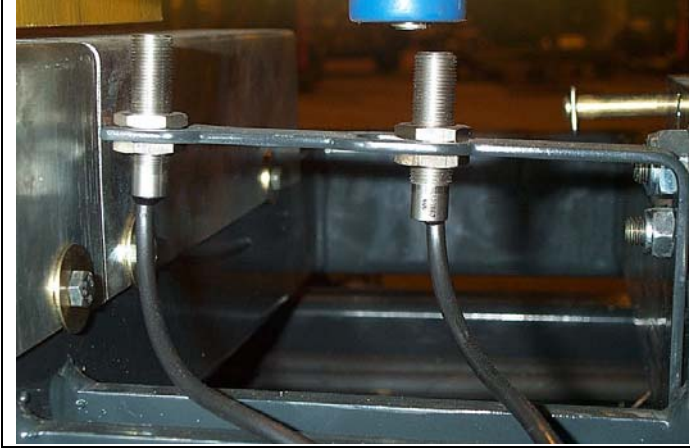

Fig 8.5.1- Rotate & Load Position Sensors

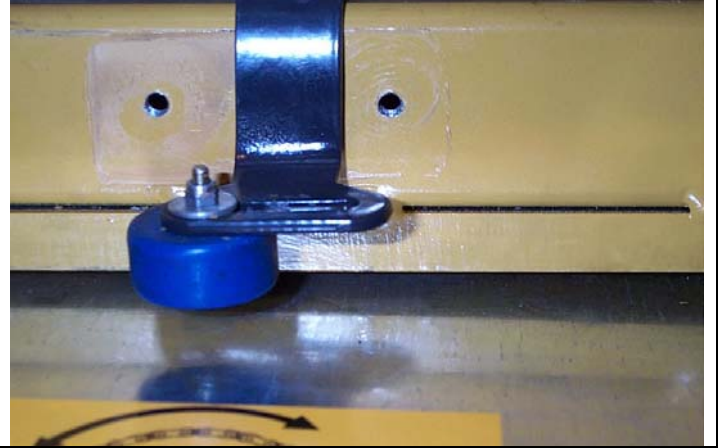

Fig. 8.5.2- Rotate Position Magnet

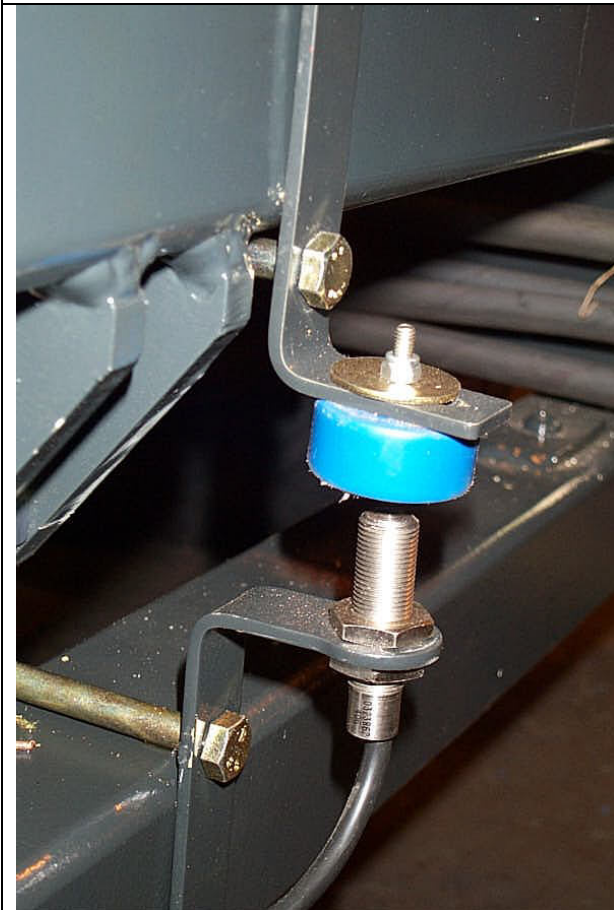

Fig 8.5.3- Table Horizontal Sensor



Fig 8.5.4 - Load Arm Down Sensor



8.5 CONDITIONS OF OPERATIONS:

In order to prevent the machine doing damage to itself, certain conditions have been put on the wrapper to ensure that it cannot damage itself.

8.5.1 Load arm function.

The sensor inputs required to enable operation of the load arm are:

- Table Horizontal
- Turntable in Load Position.

8.5.2 Turntable function.

The sensor inputs required to enable operation of the turntable are:

- Load arm down
- Table Horizontal

8.5.3 Tip up/down function.

The sensor inputs required to enable operation of the tipping function are:

- Turntable in Tip position (Rotate sensor active)



9.0 PERIODIC MAINTENANCE.

9.1 BEARINGS.

All ball-bearings are packed with grease, and do not need any more maintenance.

9.2 DISPENSER.

If the machine is in daily use, the guiding sleeves at the pre-stretcher should be oiled once a week or when needed. Gears on the pre-stretcher should also be greased when needed.

9.3 CHAINS.

Oil the chains at regular intervals. Take them off once a year for cleaning and oiling. Soak the chains in oil for 2-3 days and afterwards hang up for 10-12 hours to drain.

After some use, the chain from the motor to the turntable has to be adjusted. Unlock the nuts on the motor bracket, and tighten up the adjustment.

DO NOT TIGHT TOO MUCH, CAUSE THIS WILL INCREASE THE WEARING OF THE BEARINGS.

The chains on the square rollers also have to be adjusted. There is one chain tensioner on each side.

9.4 GEARS.

The Bevel gears in the turntable's center (below the cover) must be greased when required.

9.5 HYDRAULIC CYLINDERS.

Make sure that the hydraulic cylinder is closed when storing the machine.

9.6 CLEANING.

The machine should be cleaned and oiled regularly and by the end of the wrapping season.

NB! When using a steamer, you need to be careful with the electric equipment and bearings. Keep the counter protected from rain or water.

9.7 QUICK COUPLERS.

Be careful to keep the quick couplers clean and apply the dust caps after use. The connecting hoses are to be placed in the holders, on the side of the machine when not in use.

9.8 STORAGE.

The machine should be parked on a dry place during the closed season.



10.0 CHECK POINTS BEFORE TROUBLE SHOOTING.

In this chapter we have some general check points that have to be examined first if something is wrong with the machine. In chapter 11.0 we have a more detailed trouble shooting. There are two basic assumptions that have to be fulfilled if the machine shall function properly:

1. The oil pressure from tractor should be 180 bar.
2. The return flow of oil has to be as free as possible, max. 10 bar return pressure.

10.1 OIL PRESSURE.

In order to check that the oil pressure into the machine is high enough, fit a pressure gauge to the oil pressure hose, for example on the quick coupler. If the pressure is less than 180 bar (when energizing a function), there will be less power for the functions.

OIL AMOUNT.

The oil amount that the tractor delivers must be minimum 15 liters/minute, (Max. allowed oil amount is 45 litres/minute).

REMEMBER! Large oil amount = Valves get hot. (Small oil tank = insufficient cooling).

10.2 RETURN PRESSURE.

The return line pressure can be too high. With high return pressure the machine's functions will get less power. High return pressure means also that you need more power to operate the valves. **MAX. ALLOWED RETURN PRESSURE IS 10 BAR.**

If you are in doubt about the return pressure, arrange a "free return" directly to the tank.

**PLEASE CONTACT YOUR DEALER IF YOU ARE IN DOUBT OF ANYTHING.
(Remember always to give your dealer the serial number and production year of your machine when contacting dealer and when ordering spare parts).**



11.0 TROUBLE SHOOTING.

BEWARE OF MOVING PARTS WHEN TESTING THE MACHINE.

11.1 THE MACHINE DOES NOT WORK.

- a) The guage shows that there is enough pressure but there is no reaction from the machine. The problem can be that one or both of the quick couplers are not opening to let the oil through.

Change the quick couplers.

- b) The return pressure may be to high.
Max. return pressure is 10 bar

11.2 THE TABLE WILL NOT ROTATE.

- a) The safety valve on the motor, may be leaking, so that the oil passes the motor. Disengage the valve and check that the piston moves freely.
- b) Check if the oil motor is working.
Ask your dealer for advice BEFORE you make the error larger and more difficult to repair.

11.3 LOAD ARM, TILT, TABLE OR CUTTER DOES NOT FUNCTION.

The cables have degraded, and must be replaced or there is a loose connection somewhere. Consult your dealer.

11.4 RETURN OFF KNIFE CYLINDER. PRESSURE SETTING THE ACCUMULATOR.

- A. Drive the knife cylinder to closed position.
- b. Remove plug from the diverter valve behind the accumulator.
- c. Connect hose from + knife cylinder on the diverter valve.
- d. Open the knife with knife close function. (low pressure)
- e. Connect hose back to knife cylinder
- F. Test the knife.
- G. If the knife dos not close, let out oil pressure on the return side of the knife cylinder until the knife is closed
- H. If the knife dose not open, the pressure on return side its to high.

11.5 THE KNIFE WILL NOT HOLD THE PLASTIC FILM.

Check the pressure in the accumulator, see chapter 11.4.

There are 3 basics which must ALWAYS be followed if the machine is to function correctly.

NOTE !

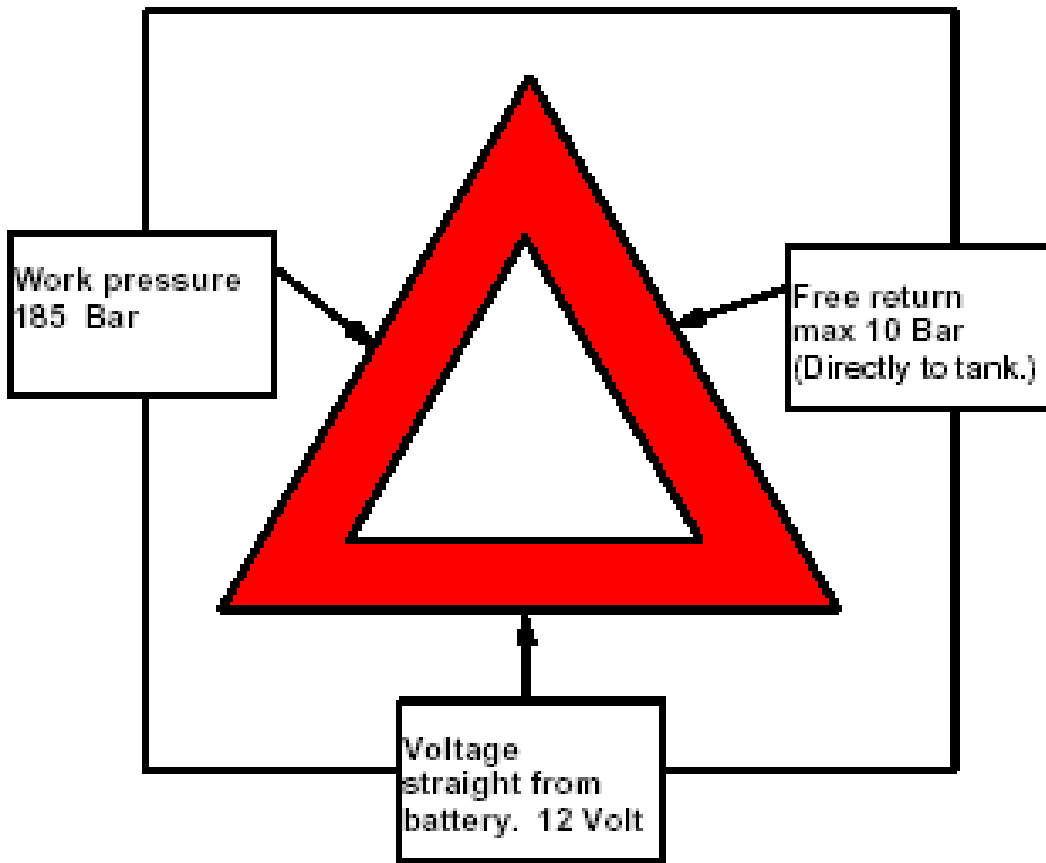

12.0 HYDRAULIC CHART

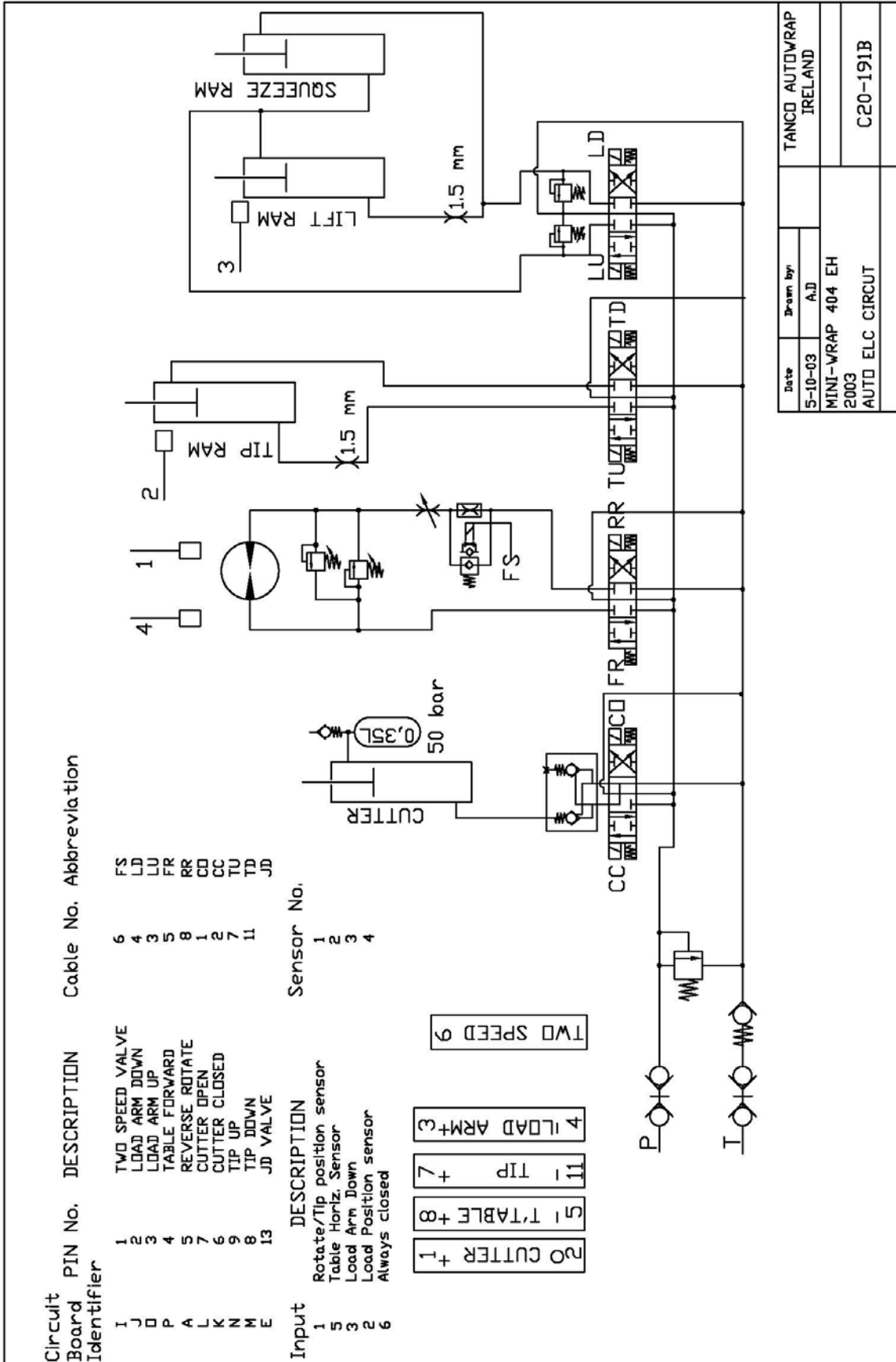

13.0 OPEN / CLOSED CENTRE CONVERSION

All Tanco machine are fitted with open center hydraulic systems. If you are using a tractor with a closed center system you will need to convert the machine to closed centers. The conversion between closed (e.g. if using a John Deere Tractor) and open center hydraulic system, is carried out by changing a plug in the main valve block. This plug is located on the valve just beside the outlet (T line). Remove the existing one and replace with closed center plug (Part No. Z01-03-A580J).

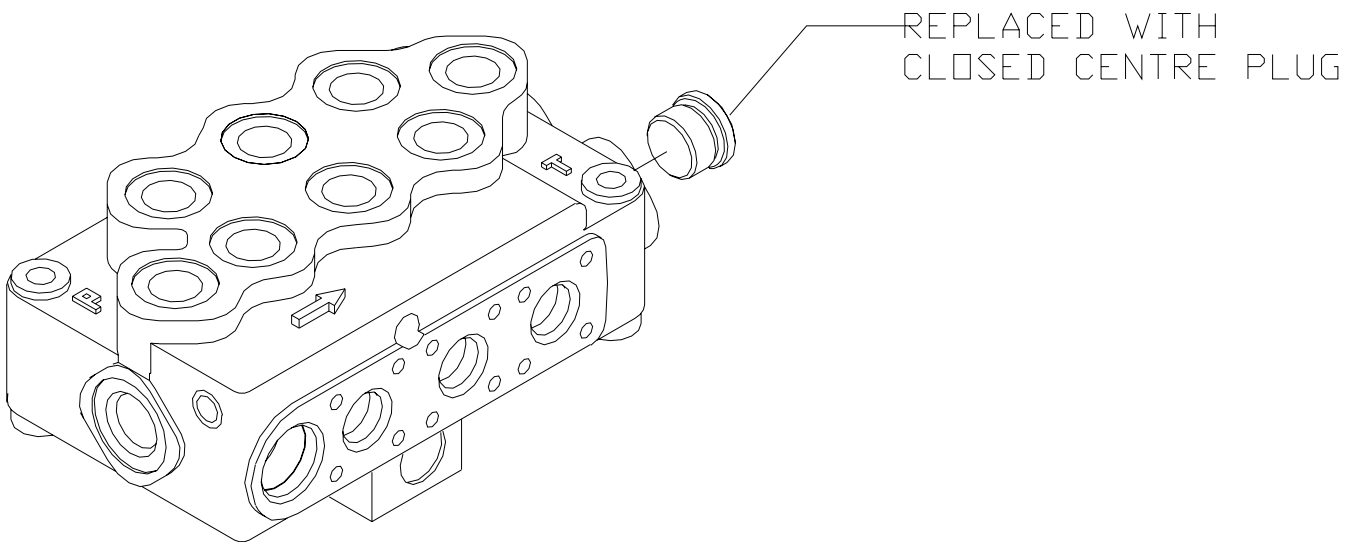

If you are likely to change frequently between open and closed centered hydraulic systems and special plug incorporating a tap can be ordered. (Part No. 1008050- closed center tap plug). This is fitted in the same position on the valve.



17. Warranty claim form

Customer details

Name & address;

Contact number and Name

Machine details

Date & dealer details purchased from;

/ /

Fault reported / work requested;

Work carried out;

Additional work required

Parts used

Part number or description	Qty	Cost
----------------------------	-----	------

Costs incurred

Miscellaneous costs

Total

=

Labour

Hrs X =

Parts cost

=

Grand total

=

Warranty Y /N ___ Claim No _____



EU DECLARATION OF CONFORMITY

ACCORDING TO DIRECTIVES 89/392/336/EEC AS AMENDED

Manufacture: TANCO AUTOWRAP LTD
BAGENALSTOWN
CO CARLOW
IRELAND

CERTIFIES THAT THE FOLLOWING PRODUCT:

AUTOWRAP

MODEL: 404 EH

SERIAL NO.:

To which this declaration relates, corresponds to essential requirements of the Directive 89/392/336/EEC as amended.

To conform to these essential health and safety requirements, the provisions of the following harmonised standards were particularly considered:

EN 292 – 1,2, EN 294, EN1152, prEN 703, prEN 811, prEN 1553, prEN 982.

DATE: __/__/____

SIGNATURE: _____

ANDREW DEASY
TECHNICAL MANAGER