

Tension Control Clutches



Models TCC-10, TCC-14, TCC-20



In accordance with Nexen's established policy of constant product improvement, the specifications contained in this manual are subject to change without notice. Technical data listed in this manual are based on the latest information available at the time of printing and are also subject to change without notice.

Technical Support: 800-843-7445
(651) 484-5900

www.nexengroup.com

	<p data-bbox="542 562 834 617"> DANGER</p> <p data-bbox="345 632 1179 852">Read this manual carefully before installation and operation. Follow Nexen's instructions and integrate this unit into your system with care. This unit should be installed, operated and maintained by qualified personnel ONLY. Improper installation can damage your system, cause injury or death. Comply with all applicable codes.</p>	
---	--	---

This document is the original, non-translated, version.

Conformity Declaration: In accordance with Appendix II B of CE Machinery Directive (2006/42/EC):

A Declaration of Incorporation of Partly Completed Machinery evaluation for the applicable EU directives was carried out for this product in accordance with the Machinery Directive. The declaration of incorporation is set out in writing in a separate document and can be requested if required.

This machinery is incomplete and must not be put into service until the machinery into which it is to be incorporated has been declared in conformity with the applicable provisions of the Directive.

Nexen Group, Inc.
560 Oak Grove Parkway
Vadnais Heights, Minnesota 55127

ISO 9001 Certified

Copyright 2014 Nexen Group, Inc.

TABLE OF CONTENTS

General Specifications	1
General Safety Precautions	1
Caliper & Housing Assembly	2
Straight Bore Assembly	3
QD Rotor Hub Assembly	4
Friction Facing Assembly	5
Lubrication	5
Air Connections	6
Operation	7
Maintenance	7
Troubleshooting	8
Parts Replacement	
Friction Facing Replacement	8
Airline Replacement	9
Diaphragm Replacement	9
Bearing Replacement	10
Replacement Parts List	11
Accessories	12
Warranty	13

GENERAL SPECIFICATIONS

Specifications	
Torque	Up to 1175 Nm (10400 in-lbs)
Actuation Pressure	1 - 5.5 bar (14.5 - 80 psi)
Service Temperature	4.5° - 104° C (40° - 220° F)
Approximate Weight	Up to 76 kg (168 lbs)

GENERAL SAFETY PRECAUTIONS



CAUTION

Use appropriate guarding for moving components. Failure to guard could result in serious bodily injury.



CAUTION

Use lifting aids and proper lifting techniques when installing, removing or placing this product in service.



CAUTION

Watch for sharp features when interacting with this product. The parts have complex shapes and machined edges.



WARNING

This product is capable of emitting a spark if misused, therefore is not recommended for use in any explosive environment.



CAUTION

This product has possible pinch points. Care should be taken when interacting with this product.



WARNING

Ensure proper guarding of the product is used. Nexen recommends the machine builder design guarding in compliance with OSHA 29 CFR 1910 "Occupational Safety and Health Hazards."

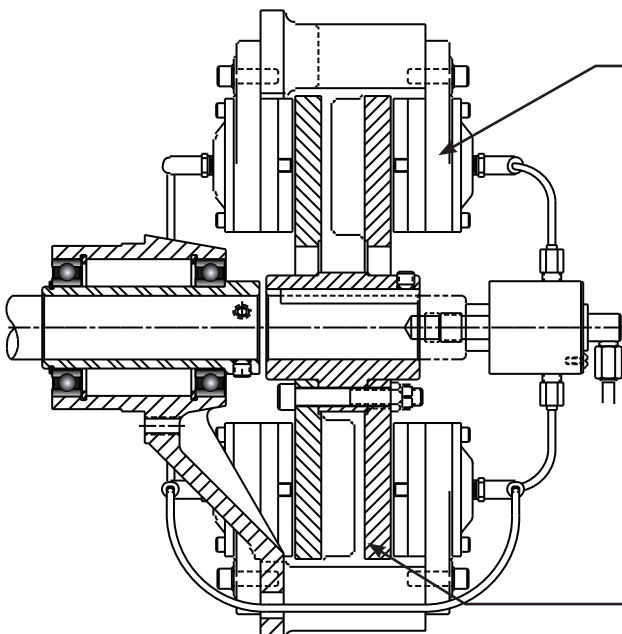



CAUTION

Surface temperature may exceed safe handling limits during operation. Do not touch.



CAUTION

This product has possible pinch points. Care should be taken when interacting with this product.

CALIPERS AND HOUSING ASSEMBLY

REFER TO FIGURES 1-5.

1. Drill a $37/64$ " diameter hole 1" deep and tap 5/8-18 UNF-2A by $25/32$ " deep into the end of the shaft. Install a Rotary Air Union into the shaft.

NOTE

Nexen recommends using a Nexen Rotary Air Union, part number 835139.

2. Use customer supplied cap screws to fasten the customer supplied sheave or sprocket to the pilot diameter of the Housing (Item 8).
3. Install either an Elbow Fitting (Item 15) or a Tee Fitting (Item 16), as required, on each caliper half.
4. Install a Friction Facing (Item 9) on each caliper half and secure it with the enclosed Machine Screw (Item 10). Tighten the Machine Screw to 18-19 in-lbs [2.0-2.1 Nm].

NOTE

Internal springs return the Caliper piston to the disengaged position to guarantee clearance between Friction Facing and Rotor when no air pressure is applied. The use of this spring is optional; the low air pressure setting is more sensitive without the springs. To remove the spring, refer to the Replacement Parts List.

5. Mount the Friction Facing and Caliper assembly on the Housing (Item 1) as directed in either the Straight Bore Rotor Hub assembly instructions or the Taper Bore Rotor Hub assembly instructions.

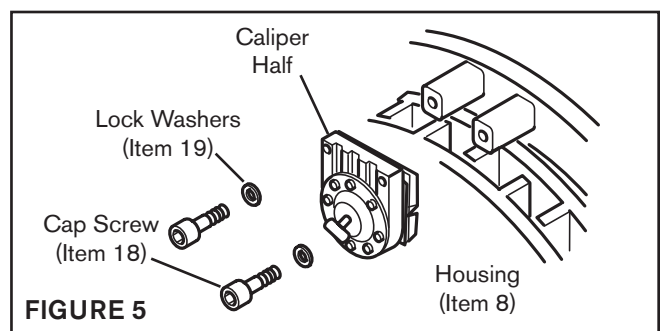
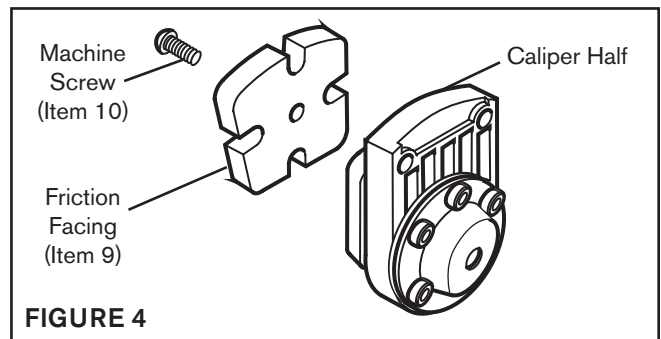
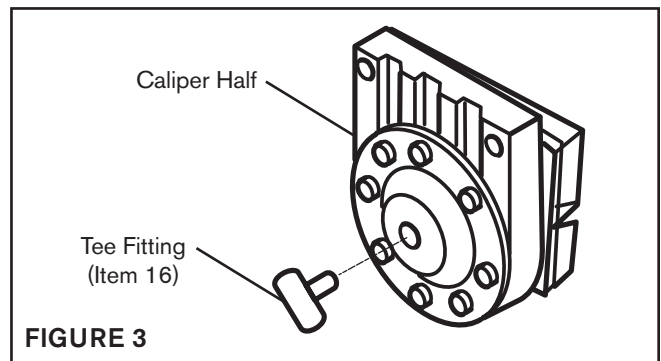
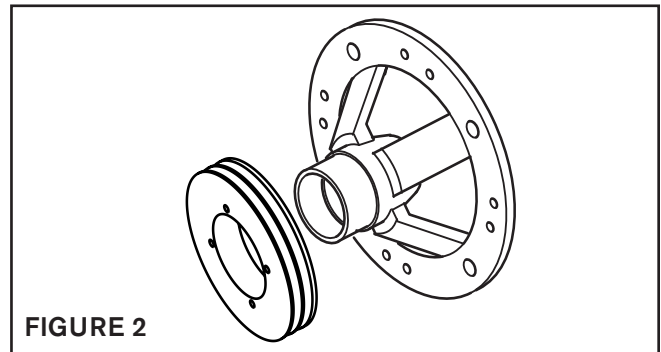
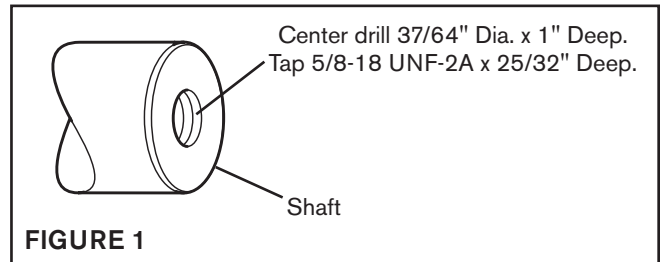

STRAIGHT BORE ROTOR HUB ASSEMBLY

Please verify that you are in the correct rotor section for your model. This is the Straight Bore Rotor Hub instruction section. The instructions for the Taper Bore Rotor Hub are in the following section.

REFER TO FIGURE 6.

1. Slide the Housing Assembly on to the shaft and tighten the Set Screw (Item 26) to the torque recommended in Table 1.
2. Align the Key (Item 6) with the Hub keyway and slide the Hub and Rotor assembly (Items 1-5) onto the shaft. Insert the Key (Item 6) into the keyway.
4. Tighten the Set Screw (Item 7) on the Hub (Item 1) to the recommended torque (See Table 1).
5. Use the Cap Screws (Item 18) and the Lock Washers (Item 19) to fasten one-half of the Caliper and Friction Facing assembly to the flange side of the Housing (Item 8) at each caliper position. Tighten the Cap Screws to 7 ft-lbs [9.5 Nm]

NOTE

Allow 1/16" [16 mm] clearance between the friction facings and the Rotor Disc (Item 2).

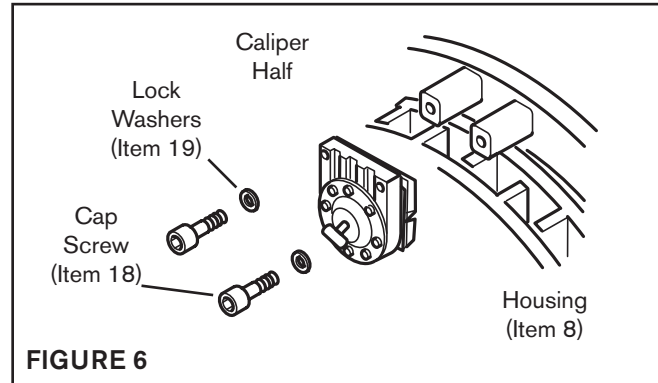

TABLE 1 Tightening Torques

Description	TCC-10	TCC-14	TCC-20
Rotor Set Screw (Item 7)	23 ft-lbs [30.9 Nm]	50 ft-lbs [67.5 Nm]	166 ft-lbs [224.0 Nm]
Housing Set Screw (Item 26)	23 ft-lbs [30.9 Nm]	50 ft-lbs [67.5 Nm]	166 ft-lbs [224.0 Nm]
Caliper Cap Screw (Item 18)	27 ft-lbs [36.4 Nm]	27 ft-lbs [36.4 Nm]	27 ft-lbs [36.4 Nm]

Q.D. (TAPER BORE) ROTOR HUB ASSEMBLY

Please verify that you are in the correct rotor section for your model. This is the Q.D. Taper Bore Rotor Hub section. The instructions for the Straight Bore Rotor Hub are in the previous section.

REFER TO FIGURES 7-8.

1. Thoroughly inspect the tapered bore of the splined hub and the tapered surface of the Q.D. bushing. Remove any dirt, grease, or foreign particles. Do not use any lubricants for this installation. Align the untapped holes in the bushing with the tapped holes in the hub and assemble the Q.D. bushing into the splined hub.
2. Insert the pull-up bolts with Lock Washers into the Q.D. bushing and hub and then alternate as you tighten them evenly to the recommended torque (See Table 2).

	CAUTION
Do not use lubricants or thread locking compounds on these bolts or they may tighten beyond the limits noted in Table 2 and the splined hub may burst.	

3. Place the Key in the shaft keyway, slide the rotor assembly onto the motor shaft.
4. Alternate as you evenly tighten the pull-up bolts to the recommended torque (See Table 2).

	CAUTION
The tightening force on the pull-up bolts is multiplied by the wedging action of the tapered surface. Do not tighten beyond the limits noted in Table 2 or the splined hub may burst.	

5. Use a Dial Indicator to minimize run-out as you tighten the Q.D. bushing pull-up bolts. To measure run-out, place the contact tip of the Dial Indicator on the machined surface of the Rotor. Maximum run-out must be less than 0.007" [18 mm].
6. Use the Cap Screws (Item 18) and the Lock Washers (Item 19) to fasten one-half of the Caliper and Friction Facing assembly to the flange side of the Housing (Item 8) at each caliper position. Tighten the Cap Screws to 7 ft-lbs [9.5 Nm]

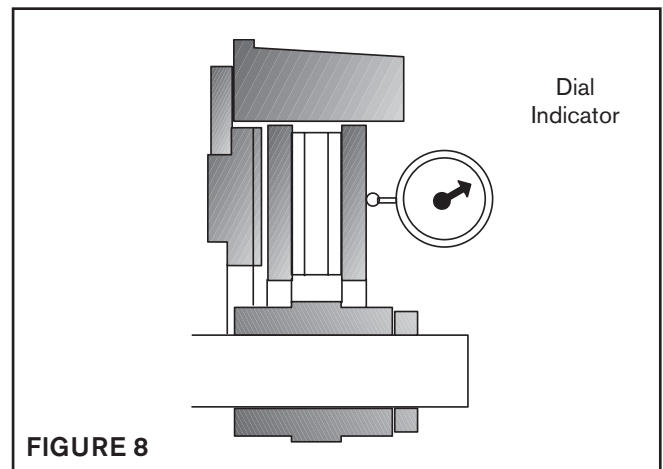
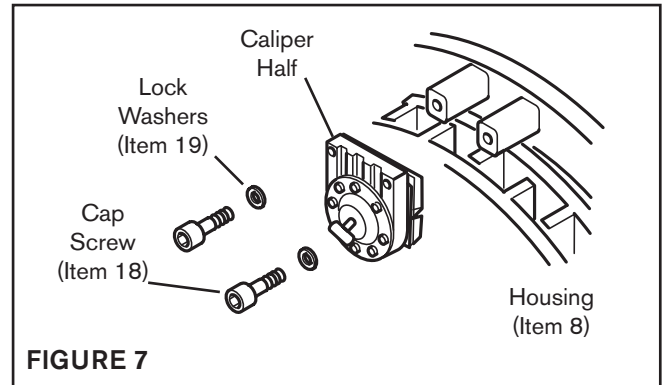

TABLE 2 Tightening Torques

Model	Bushing	Tightening Torque
TCC-10	JA	5 ft-lbs [6.7 Nm]
TCC-14	SK	15 ft-lbs [20.2 Nm]
TCC-20	J	135 ft-lbs [182.2 Nm]

FRICION FACING & CALIPER ASSEMBLY

REFER TO FIGURES 9 - 10.

1. Place a 1/16" [1.6 mm] shim between the friction facings and the Rotor Disc (Item 2). As you rotate the Rotor Disc past each caliper, check for equal clearance at all positions.
2. Use the Machine Screw (Item 10) to secure the Friction Facing to the caliper and install a Friction Facing (Item 9) onto each remaining caliper half. Tighten the Machine Screw to 18-19 in-lbs [2.0-2.1 Nm].
3. Use Lock Washers (Item 19) and Socket Head Cap Screws (Item 18) to attach the caliper halves at each caliper position. Tighten the Socket Head Cap Screws to 7 ft-lbs [9.5 Nm].
4. Install a Tee Fitting (Item 16) or an Elbow Fitting (Item 15) into each remaining caliper half.

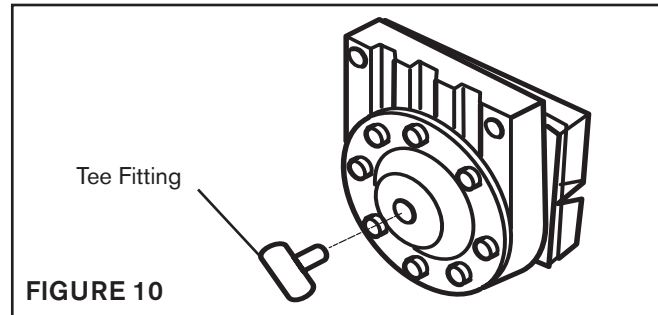
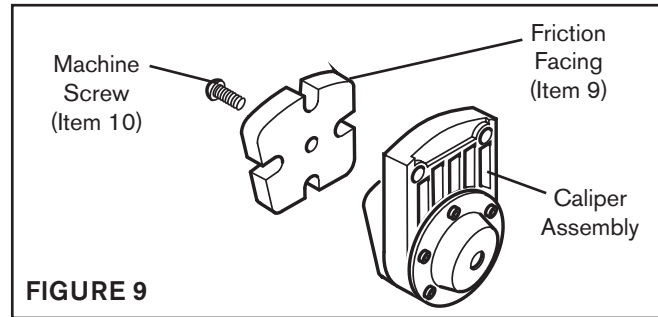

LUBRICATION

NOTE

Nexen pneumatically actuated devices require clean, pressure regulated air for maximum performance and life. All seals in Nexen pneumatically operated devices are lubricated for life, and do not require additional lubrication.

However, some customers prefer to use an air line lubricator, which injects oil into the pressurized air, forcing an oil mist into the air chamber. This is acceptable, but care must be taken to ensure once an air mist lubrication system is used, it is continually used over the life of the product as the oil mist may wash free the factory installed lubrication.

Locate the lubricator above and within ten feet of the product, and use low viscosity oil such as SAE-10.

Synthetic lubricants are not recommended.

Nexen product's bearings are shielded and pre-lubricated, and require no further lubrication.

LUBRICATOR DRIP RATE SETTINGS

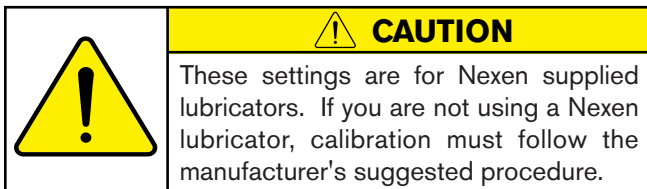

1. Close and disconnect the air line from the unit.
2. Turn the Lubricator Adjustment Knob counterclockwise three complete turns.
3. Open the air line.
4. Close the air line to the unit when a drop of oil forms in the Lubricator Sight Gage.
5. Connect the air line to the unit.
6. Turn the Lubricator Adjustment Knob clockwise until closed.
7. Turn the Lubricator Adjustment Knob counterclockwise one-third turn.
8. Open the air line to the unit.

NOTE

DO NOT lubricate the caliper diaphragms. If you use a lubricant on the air line for the controls, use a lubricant that is compatible with the silicone diaphragm.

AIR CONNECTIONS

All Nexen pneumatically actuated devices require clean, dry air that meets or exceeds ISO 8573.1:2001 Class 4.4.3 to quality.

NOTE

For quick response, Nexen recommends a quick exhaust valve and short air lines between the Control Valves and the unit. Align the air inlet ports to a down position to allow condensation to drain out of the air chambers of the product.



CAUTION

Low air pressure will cause slippage and overheating. Excessive air pressure will cause abrupt starts and stops, reducing product life.

Use the length of 5/32" [4 mm] O.D. nylon air line air line that is supplied to make the connections between the calipers. (See Table 3 for Air Line Specifications).

REFER TO FIGURES 11 - 12.

1. Screw the Rotary Air Union assembly into the shaft end.
2. Install the air line by pushing it into the fitting until it stops. The Elbow and Tee Fittings (Items 15 and 16) are push-lock fittings for instant connection and disconnection.

To disconnect, first push the fitting collar in and then pull the air line out. Make certain that all fittings are properly tightened.

NOTE

Each caliper comes with one elbow fitting, two tee fittings and 13.5" [34.3 cm] of air line tubing. Not all of the fittings are used to make caliper connections. Save the extra fittings for replacement parts.

2. Route the air lines from the Rotary Air Union to the individual caliper assemblies (See Figure 4).



CAUTION

Air lines must be the same length for the clutch to balance properly.

The following is a common air supply scheme used with this product. This is an example and not an all-inclusive list. All air circuits to be used with this product must be designed following ISO 4414 guidelines.

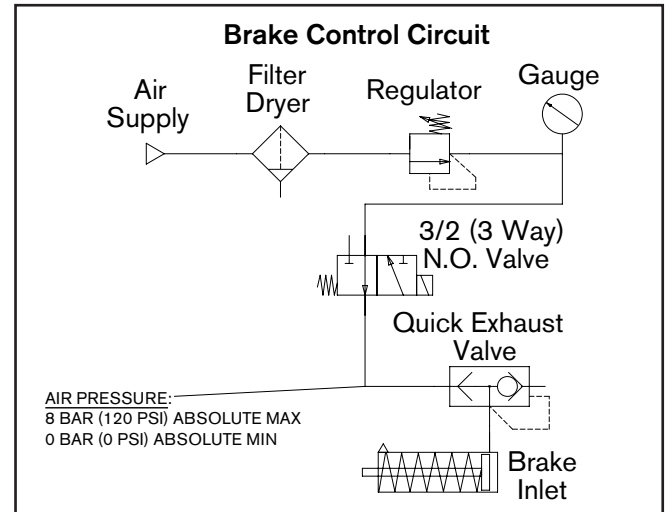

TABLE 3 Air Line Specifications

O.D.	I.D.	Min. Bend Radius	Burst Pressure	Material
0.1560" [4 mm]	0.106" [2.7 mm]	3/4" [19 mm]	1000 PSI @ 75° F	Nylon-11

Push in the push-lock collar and it will release the air line

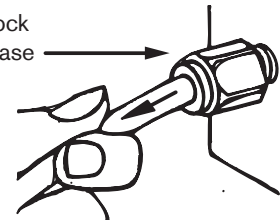
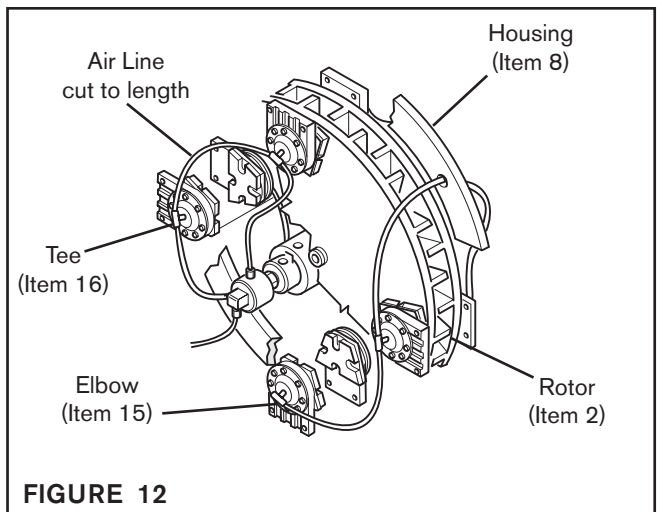





FIGURE 11



OPERATION



	 WARNING
Ensure proper guarding of the product is used. Nexen recommends the machine builder design guarding in compliance with OSHA 29 CFR 1910 "Occupational Safety and Health Hazards."	

	 WARNING
DO NOT exceed maximum operating speed (See Table 4). If you exceed maximum operating speeds, you may damage or decrease the performance and the life of the Tension Control Clutch.	

Check all screws and fasteners for proper tightening torque BEFORE operating the unit. (See Table 5). Overtightening can cause the screws and fasteners to fail. Under-tightening can reduce the performance of the Tension Control Clutch.

For optimum clutch action, connect the controls as close to the unit as possible. Nexen recommends the installation of an air line filter in the air line ahead of the controls.

For automatic tension control, use Nexen's Electronic Tension Control System. Contact your local Nexen Web Handling distributor or representative for information concerning this product.

	 CAUTION
Never exceed life of facing material. Facing life depends on the volume of material and the total energy over the life of the unit. Expected life (in hrs) can be found by: Time = $\frac{\text{Volume}}{(\text{Power} \cdot \text{Wear Rate})}$	



	 CAUTION
The temperature limits for this product line are 4.5° - 104° C (40°-220° F).	

TABLE 4 Maximum Operating Speeds

Model	RPM
TCC-10	1500
TCC-14	1200
TCC-20	900

TABLE 5 Screw & Fastener Tightening Torques

Description	TCC-10	TCC-14	TCC-20
Rotor Set Screw (Item 7)	23 ft-lbs [30.9 Nm]	50 ft-lbs [67.5 Nm]	166 ft-lbs [224.0 Nm]
Housing Set Screw (Item 26)	23 ft-lbs [30.9 Nm]	50 ft-lbs [67.5 Nm]	166 ft-lbs [224.0 Nm]
Caliper Cap Screw (Item 18)	27 ft-lbs [36.4 Nm]	50 ft-lbs [67.5 Nm]	27 ft-lbs [36.4 Nm]

MAINTENANCE

Inspect all cap screws and set screws on a regular basis and make sure they are tightened to the recommended torque. Inspect the friction facings regularly and replace them when worn to approximately 5/32" [4 mm] thick.

TROUBLESHOOTING

SYMPTOM	PROBABLE CAUSE	SOLUTION
Failure to engage.	Air not getting to TCC Clutch. Low air pressure. Control malfunction	Check for control valve malfunction or low air pressure. Check controls.
Failure to disengage.	Unexhausted air. Control malfunction.	Check for control valve malfunction. Check Controls.
Loss of torque.	Air leak.. Friction facing contamination.. Low air pressure. Worn friction facings.	Check for air leaks. Check air pressure. Replace facings.
Friction Facing squeal or chatter.	Air pressure too high. Wrong friction facing for application.	Reduce air pressure. Check friction facing.
Noise (other than facing squeal).	Bearing failure. Loose fasteners.	Replace bearings. Tighten fasteners.
Wobble or vibration.	Improper mounting. Faulty shaft.	Remount unit. Replace shaft.

PARTS REPLACEMENT

FRICION FACING REPLACEMENT

REFER TO FIGURES 13 & 14.

1. Stop the machine and shut off air supply to the unit.
2. Remove the Socket Head Cap Screws (Item 18) and the Lock Washers (Item 19).
3. Remove the Caliper Assembly from the Housing (Item 8).
4. Remove the Machine Screw (Item 10) from back of the Caliper Assembly and remove the Friction Facing (Item 9).
5. Install the new Friction Facing (Item 9) and secure it to the Caliper Assembly with the Machine Screw (Item 10). Tighten the Machine Screw to 18-19 In. Lbs. [2.0-2.1 Nm].
6. Place the Caliper Assembly in position and secure it to the Housing with Socket Head Cap Screws (Item 18) and Lock Washers (Item 19).
7. Tighten the Socket Head Cap Screws to 27 ft-lbs [36.4 Nm] torque.

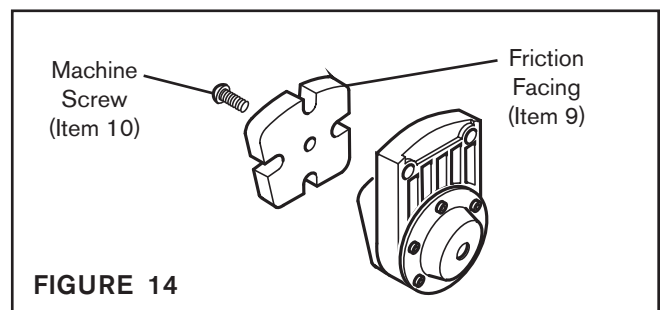
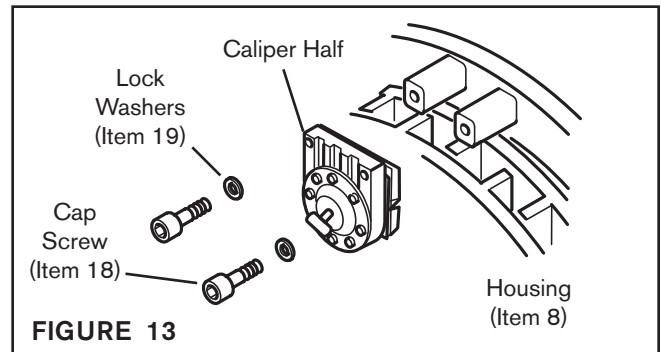

PARTS REPLACEMENT continued

AIRLINE REPLACEMENT

REFER TO FIGURE 15.

1. To disconnect an air line, first push the fitting collar in and then pull the air line out.
2. To install a new air line, push the air line into the fitting until it stops.

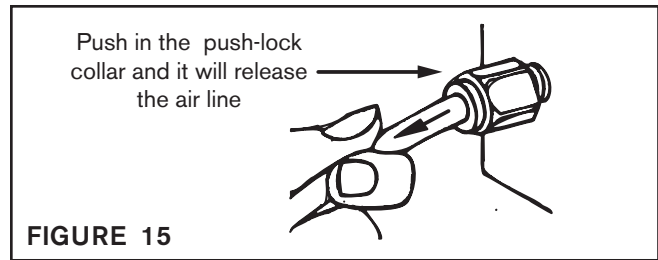

DIAPHRAGM REPLACEMENT

REFER TO FIGURE 16.

1. Disconnect the air line.
2. Remove the Socket Head Cap Screws (Item 18) and Lock Washers (Item 19).
3. Remove the Caliper Assembly from the Housing.
4. Remove six Cap Screws (Item 20) and the Cover (Item 13) from the Cylinder (Item 11).
5. Remove the Diaphragm (Item 14).

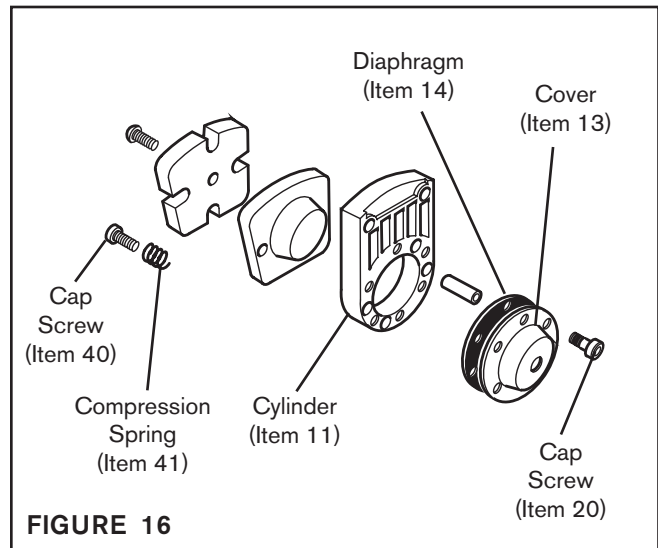

NOTE

Internal Compression Springs (Item 41) may also be removed at this time. These springs are optional; the low air pressure setting is more sensitive without the springs.

6. Reinsert the new Diaphragm (Item 14) and reassemble the Caliper.
7. Tighten the Cap Screw (Item 40) to 22 ft-lbs [29.6 Nm] and the Cap Screw (Item 20) to 5.5 ft-lbs [7.4 Nm] torque.

PARTS REPLACEMENT continued

BEARINGS REPLACEMENT

REFER TO FIGURE 17.

1. Stop the machine and shut off the air supply to the Tension Control Clutch.
2. Remove the Tension Control Clutch.

NOTE

To remove the Q.D. bushing, remove the Cap Screws; then, reinsert them into the threaded holes and tighten them to push the Rotor off the Q.D. bushing.

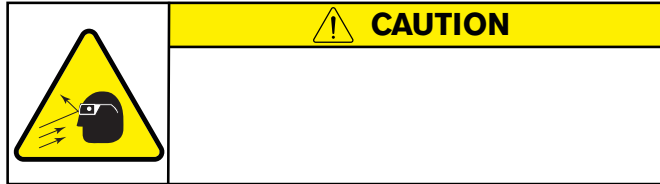

3. Remove all the caliper assemblies and air lines from the housing assembly.
4. Remove the Retaining Ring (Item 24) from the Hub (Item 30).
5. Fully support the Housing (Item 8), then press the Hub (Item 30) out of the Bearings (Item 23).
6. Use a bearing puller to remove the Bearings (Item 23) from the Housing (Item 8).
7. Clean the bore of the Housing (Item 8) with fresh safety solvent. Make sure that all of the old Loctite® residue is removed.
8. Apply Loctite® 680, or equivalent, to the outer race of the new bearing and press the bearings into the Housing.

NOTE

Carefully align the bearing O.D. with the Housing bore when you install the bearings.

9. Support the bearing inner race then press the Hub (Item 30) into the Housing (Item 8).
10. Reinsert the Retaining Ring (Item 24).
11. Reinstall the Tension Control Clutch

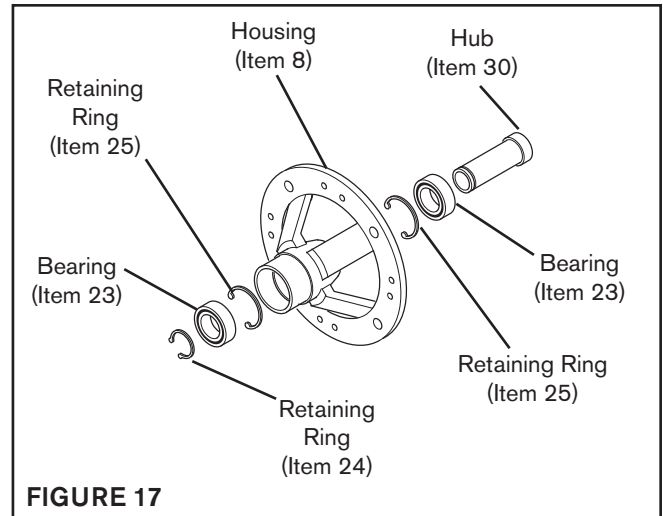

REPLACEMENT PARTS LIST

The item or balloon number for all Nexen products is used for part identification on all product parts lists, product price lists, unit assembly drawings, bills of materials, and instruction manuals.

When ordering replacement parts, specify model designation, item number, part description, and quantity. Purchase replacement parts through your local Nexen Distributor.

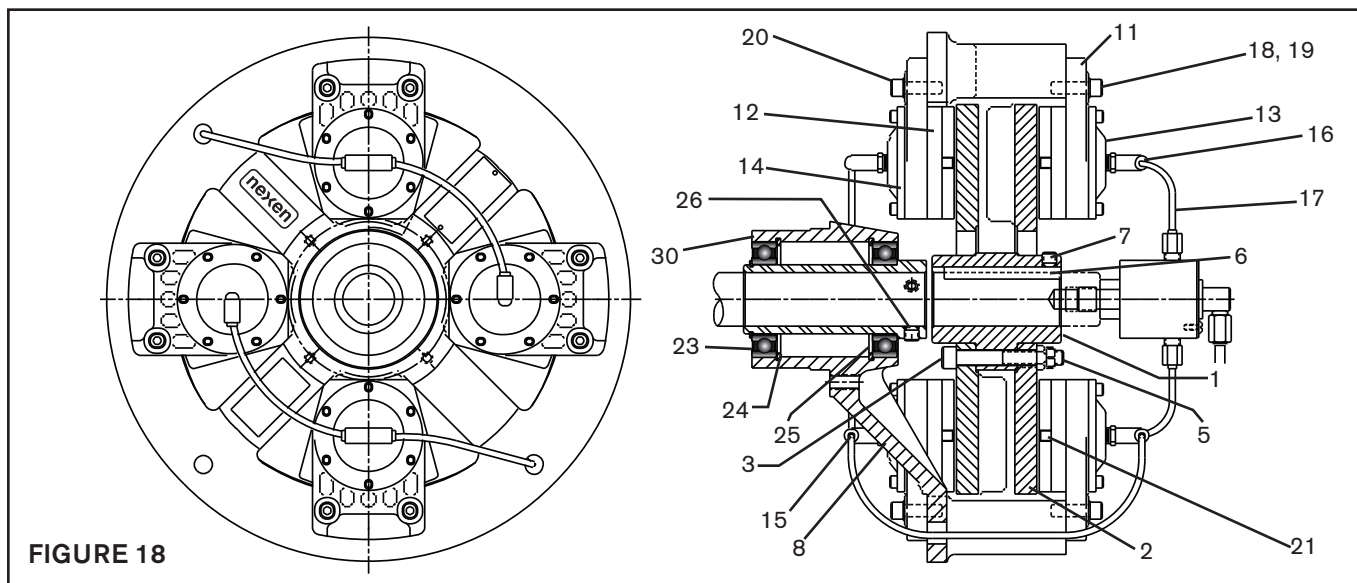

FIGURE 18

Housing

ITEM	DESCRIPTION	QTY
8	Housing	1
23	Bearing	2
24	Retaining Ring	1
25	Retaining Ring	2
26	Set Screw	3
30	Hub	1

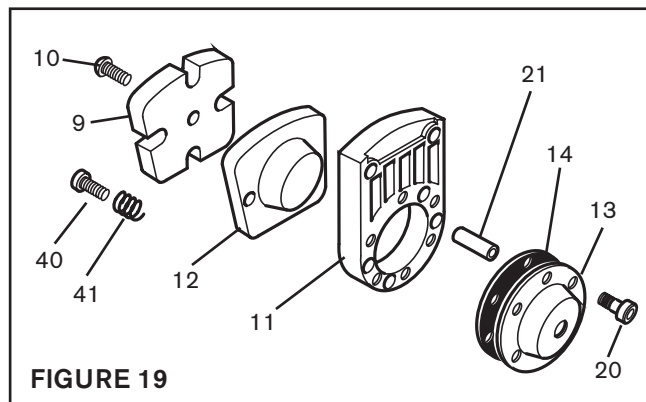

FIGURE 19

Caliper

ITEM	DESCRIPTION	QTY
9	Friction Facing	1
10	Machine Screw	1
11	Cylinder	2
12	Piston	2
13	Cover	2
14	Diaphragm	2
15	Elbow Fitting, 90°	1
16	Tee Fitting	2
17	Air Line	13 1/2"
18	Socket Head Cap Screw	4
19	Lock Washer	4
20	Cap Screw	12
21	Spring Pin	4
40	Cap Screw	4
41	Compression Spring	4

Hub

ITEM	DESCRIPTION	QTY
1	Hub ¹	1
2	Rotor Disc	2
3	Cap Screw	3
5	Hex Nut	3
6	Square Key	1
7	Set Screw	2

¹ Specify taper or straight bore. Give diameter of straight bore.

ACCESSORIES

FRICION FACING KITS

The Friction Facing kit contains two friction facings of the specific coefficient of friction listed in Table 6. One facing kit is required per Caliper Assembly.

NOTE

Caliper Assemblies and Friction Facing Kits are common to all Tension Control Clutch models. When ordering replacement kits, specify one Caliper Assembly and Friction Facing Kit for each caliper position.

TABLE 6

Coefficient	Description	Product Number
.20	LOCO	835113
.35	STD.	835112
.45	HICO	835111

WARRANTY

Warranties

Nexen warrants that the Products will (a) be free from any defects in material or workmanship for a period of 12 months from the date of shipment, and (b) will meet and perform in accordance with the specifications in any engineering drawing specifically for the Product that is in Nexen's current product catalogue, or that is accessible at the Nexen website, or that is attached to this Quotation and that specifically refers to this Quotation by its number, subject in all cases to any limitations and exclusions set out in the drawing. NEXEN MAKES NO OTHER WARRANTY, EXPRESS OR IMPLIED, AND ALL IMPLIED WARRANTIES, INCLUDING WITHOUT LIMITATION, IMPLIED WARRANTIES OF MERCHANTABILITY AND FITNESS FOR A PARTICULAR PURPOSE ARE HEREBY DISCLAIMED. This warranty applies only if: (a) the Product has been installed, used and maintained in accordance with any applicable Nexen installation or maintenance manual for the Product; (b) the alleged defect is not attributable to normal wear and tear; (c) the Product has not been altered, misused or used for purposes other than those for which it was intended; and (d) Buyer has given written notice of the alleged defect to Nexen, and delivered the allegedly defective Product to Nexen, within one year of the date of shipment.

Exclusive Remedy

The exclusive remedy for the Buyer for any breach of any warranties provided in connection with this agreement will be, at the election of Nexen: (a) repair or replacement with new, serviceably used, or reconditioned parts or products; or (b) issuance of credit in the amount of the purchase price paid to Nexen by the Buyer for the Products.

Agent's Authority

Buyer agrees that no agent, employee or representative of Nexen has authority to bind Nexen to any affirmation, representation, or warranty concerning the Products other than those warranties expressly set forth herein.

Limitation on Nexen's Liability

TO THE EXTENT PERMITTED BY LAW NEXEN SHALL HAVE NO LIABILITY TO BUYER OR ANY OTHER PERSON FOR INCIDENTAL DAMAGES, SPECIAL DAMAGES, CONSEQUENTIAL DAMAGES OR OTHER DAMAGES OF ANY KIND OR NATURE WHATSOEVER, WHETHER ARISING OUT OF BREACH OF WARRANTY OR OTHER BREACH OF CONTRACT, NEGLIGENCE OR OTHER TORT, OR OTHERWISE, EVEN IF NEXEN SHALL HAVE BEEN ADVISED OF THE POSSIBILITY OR LIKELIHOOD OF SUCH POTENTIAL LOSS OR DAMAGE. For all of the purposes hereof, the term "consequential damages" shall include lost profits, penalties, delay damages, liquidated damages or other damages and liabilities which Buyer shall be obligated to pay or which Buyer may incur based upon, related to or arising out of its contracts with its customers or other third parties. In no event shall Nexen be liable for any amount of damages in excess of amounts paid by Buyer for Products or services as to which a breach of contract has been determined to exist. The parties expressly agree that the price for the Products and the services was determined in consideration of the limitation on damages set forth herein and such limitation has been specifically bargained for and constitutes an agreed allocation of risk which shall survive the determination of any court of competent jurisdiction that any remedy herein fails of its essential purpose.

Inspection

Buyer shall inspect all shipments of Products upon arrival and shall notify Nexen in writing, of any shortages or other failures to conform to these terms and conditions which are reasonably discoverable upon arrival without opening any carton or box in which the Products are contained. Such notice shall be sent within 14 days following arrival. All notifications shall be accompanied by packing slips, inspection reports and other documents necessary to support Buyer's claims. In addition to the foregoing obligations, in the event that Buyer receives Products that Buyer did not order, Buyer shall return the erroneously shipped Products to Nexen within thirty (30) days of the date of the invoice for such Products; Nexen will pay reasonable freight charges for the timely return of the erroneously shipped Products, and issue a credit to Buyer for the returned Products at the price Buyer paid for them, including any shipping expenses that Nexen charged Buyer. All shortages, overages and nonconformities not reported to Nexen as required by this section will be deemed waived.

Limitation on Actions

No action, regardless of form, arising out of any transaction to which these terms and conditions are applicable may be brought by the Buyer more than one year after the cause of action has accrued.

nexen[®]

Nexen Group, Inc.
560 Oak Grove Parkway
Vadnais Heights, MN 55127

800.843.7445
Fax: 651.286.1099
www.nexengroup.com

ISO 9001 Certified