

**Gefen**  
**TOOLBOX**  
**Extender**  
**for HDMI® 3DTV**  
**GTB-HDMI-3DTV-BLK**  
**User Manual**



[www.gefentoolbox.com](http://www.gefentoolbox.com)

## ASKING FOR ASSISTANCE

---

### Technical Support:

Telephone (818) 772-9100  
(800) 545-6900

Fax (818) 772-9120

### Technical Support Hours:

8:00 AM to 5:00 PM Monday thru Friday.

### Write To:

Gefen LLC  
c/o Customer Service  
20600 Nordhoff St  
Chatsworth, CA 91311

[www.gefentoolbox.com](http://www.gefentoolbox.com)  
[support@gefentoolbox.com](mailto:support@gefentoolbox.com)

### Notice

Gefen LLC reserves the right to make changes in the hardware, packaging and any accompanying documentation without prior written notice.

**GefenToolbox Extender for HDMI 3DTV** is a trademark of Gefen LLC

© 2010 Gefen LLC, All Rights Reserved.

HDMI®, the HDMI Logo, and High-Definition Multimedia Interface are trademarks or registered trademarks of HDMI Licensing LLC in the United States and other countries.

All trademarks are the property of their respective owners

# CONTENTS

---

- 1 Introduction
- 2 Operation Notes
- 3 Features
- 4 Sender Unit Layout
- 5 Sender Unit Descriptions
- 6 Receiver Unit Layout
- 7 Receiver Unit Descriptions
- 8 Connecting and Operating The Extender For HDMI 3DTV
- 9 DIP Switch Configuration
- 11 Network Cable Wiring Diagram
- 12 Wall Mounting Instructions
- 13 Specifications
- 14 Warranty

# INTRODUCTION

---

Congratulations on your purchase of the Extender for HDMI® 3DTV. Your complete satisfaction is very important to us.

## **GefenToolbox**

GefenToolbox is a unique product line catering to the growing needs for innovative home theater solutions. We specialize in total integration for your home theater, while also focusing on going above and beyond customer expectations to ensure you get the most from your hardware. We invite you to explore our distinct product line and hope you find your solutions. Don't see what you are looking for here? Please call us so we can better assist you with your particular needs.

## **The GefenToolbox Extender for HDMI 3DTV**

The GefenToolbox Extender for HDMI 3DTV extends HDMI® and 3D content including multi-channel digital audio at resolutions of up to 1080p Full HD up to 330 feet (100 meters) from any Hi-Def source using one CAT-5 cable. This product also provides an IR backchannel to control AV sources using the same CAT-5 cable extension. Using this remote IR back-channel with an optional IR Blaster, you can point to any one of the of the AV device sources, by pointing towards the IR sensor to control Hi-Def sources as if they were located in the same room or proximity to the display.

## **How It Works**

Connect the GefenToolbox Extender for HDMI 3DTV sender unit to the 3D Hi-Def source using the supplied HDMI cable. Connect the receiver unit to the 3DTV Display. Use a single CAT-5 cable, up to 330 feet (100 meters) in length, to connect the sender and the receiver units. Connect the locking power supplies to both sender and receiver units and apply power to the 3D Hi-Def source and 3DTV Display. 3D content can now be displayed on the 3DTV Display along with audio embedded in the HDMI signal.

## OPERATION NOTES

---

### READ THESE NOTES BEFORE INSTALLING OR OPERATING THE EXTENDER FOR HDMI 3DTV

- CAT-5 or CAT-6 cables should not exceed 330 feet (100 meters).
- Shielded (STP) CAT-5 or CAT-6 is recommended. However, unshielded (UTP) CAT-5 or CAT-6 is acceptable.

**NOTE:** Shielded cable has an advantage by providing immunity to Electromagnetic Interference (EMI) from cell phones and A/C motors.

- The Extender for HDMI 3DTV features the ability to generate compatible EDID and Hot Plug signals for troubleshooting purposes when dealing with difficult interfacing issues between Source devices and Displays. Please see the section on pages 9 - 10 for troubleshooting purposes.

# FEATURES

---

## Features

- Extends HDMI at 1080p up to 330 ft (100 m).
- Supports HDMI 1.3 with 3DTV.
- Supports high bit-rate multi-channel audio formats (Dolby TrueHD / DTS Master Audio) embedded in the HDMI 1.3 signal.
- Internal / External EDID Management.
- Locking power connectors.
- Built-in IR backchannel allows IR remote control of Source devices.
- Metal enclosure improves RF shielding.
- All-digital signal transmission for zero signal loss.
- Optional IR Blaster allowing IR remote control of Hi-Def source devices from the remote viewing location.
- This product is HDMI and HDCP-compliant.

## HDMI 1.3 Features

- 225 MHz (up to 12-bit YUV 4:4:4 @ 1080p60)
- Dolby<sup>™</sup> TrueHD & DTS<sup>™</sup> Master Audio
- Deep Color Support (x.v. Color)
- Lip-Sync Pass-Through
- CEC Pass-Through

## Package Includes

- (1) Extender for HDMI 3DTV Sender Unit
- (1) Extender for HDMI 3DTV Receiver Unit
- (2) 6 ft. Locking HDMI cables
- (2) 5V DC Locking Power Supplies
- (1) User Manual

# SENDER UNIT LAYOUT

---

Left

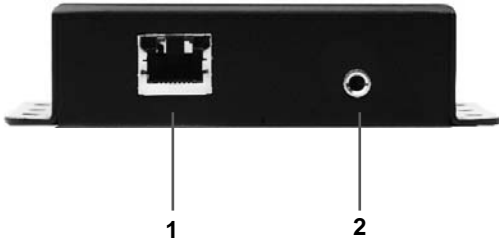

Top



Right

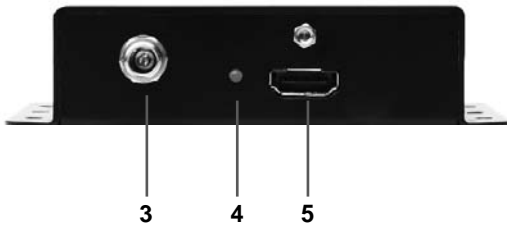

## SENDER UNIT DESCRIPTIONS

---

**1 CAT-5 Output Jack**

Connects the Sender to the Receiver unit using CAT-5 cabling.

**2 IR Blaster Port**

Connect an IR Blaster cable from this port to the Hi-Def source to control the source from the viewing location (IR Blaster not included).

**3 5V DC Locking Power Connector**

Connect the included 5V DC locking power supply to this connector. Only use the power supply shipped with this unit.

**4 Power Indicator**

This LED will turn bright red once the included 5V DC locking power supply has been properly connected to the unit and the locking power supply has been connected to an available wall outlet.

**5 Locking HDMI Port**

Connect a 3D Hi-Def source device to this HDMI port. Please see the Features section on page 3 for supported HDMI 1.3 features.



# RECEIVER UNIT LAYOUT

---

Left

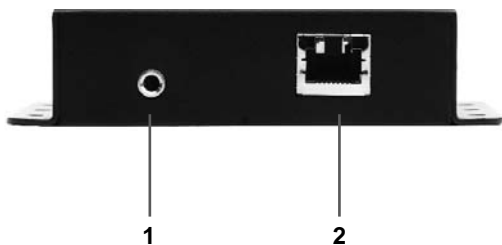

Top



Right

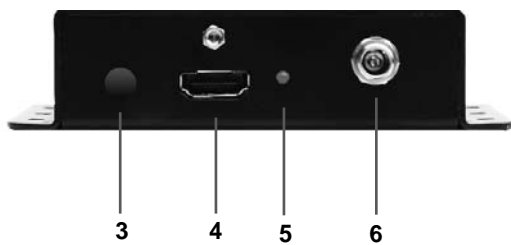

## RECEIVER UNIT DESCRIPTIONS

---

**1 *IR Extender Port***

Connect an IR extender to this port.

**2 *CAT-5 Input Port***

Connects the Receiver to the Sender unit using CAT-5 cabling.

**3 *IR Sensor***

Receives signals from the 3D source IR remote control. The IR signals are sent back to the source device, when using an IR Blaster on the Sender.

**4 *Locking HDMI Port***

Connect a 3D display to this HDMI port. Please see the Features section on page 3 for supported HDMI 1.3 features.

**5 *Power Indicator***

This LED will turn bright red once the included 5V DC locking power supply has been properly connected to the unit and the locking power supply has been connected to an available wall outlet.

**6 *5V DC Locking Power Connector***

Connect the included 5V DC locking power supply to this connector. Only use the power supply shipped with this unit.

# CONNECTING AND OPERATING THE EXTENDER FOR HDMI 3DTV

## How to Connect the Extender for HDMI 3DTV

1. Position the Extender for HDMI 3DTV sender unit near the Hi-Def source and the receiver unit next to the display. Connect the Hi-Def source to the sender with the provided locking HDMI cable. Connect the HDTV display to the receiver unit with the supplied HDMI cable.
2. Connect the sender and receiver units together using a single user-supplied CAT-5e or CAT-6 cables.

**NOTE:** If terminating network cables in the field, please adhere to the TIA/EIA568B specification (please see page 11).

3. Connect a 5V DC locking power supplies to the sender unit. Connect a 5V DC locking power supply to the receiver unit. Do not overtighten the locking connectors. Plug the two power supplies to an available wall outlet. The LED on both the Sender and Receiver will turn bright red, indicating that both units are powered.
4. Power on the HDTV display and the Hi-Def source. A vibrant HDTV HD picture will be seen, along with multichannel digital audio (if the display supports audio).

**NOTE:** If the source and display support 3D then the Extender for HDMI 3DTV will pass through the 3D signal.

## Wiring Diagram for the Extender for HDMI 3DTV

**Gefen  
TOOLBOX**

**CAT5 LINK CABLE**  (Up to 330 ft)  
**HDMI CABLE** 

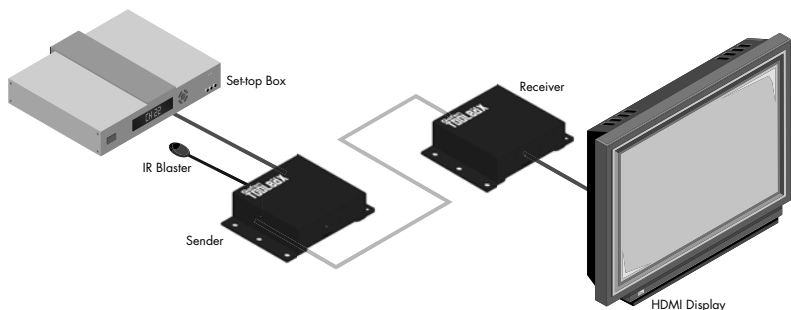

**GTB-HDMI-3DTV**

# DIP SWITCH CONFIGURATION

## DIP Switch Location

On the bottom of the Extender for HDMI 3DTV Receiver unit there are four (4) DIP switches.

The DIP switches allow advanced EDID management of the Extender for HDMI 3DTV which may be necessary when troubleshooting or using different brands of hardware. The DIP switches allow control over the EDID and the HPD (Hot Plug Detect) status.

## Receiver Unit (bottom)

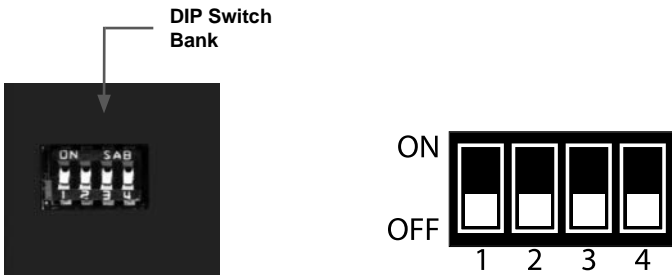

**NOTE:** DIP switch 4 is not used.

## Default settings for DIP switches

DIP Switch	Position
1	ON
2	OFF
3	OFF
4	NOT USED

# DIP SWITCH CONFIGURATION

---

## DIP 1 - EDID Mode

ON (default) - External EDID Mode

- DDC and HPD are passed through. Both the connection status and the full A/V capabilities of the display. The HPD status will also be detected by the source device.

OFF - Internal EDID Mode

- Local EDID is used instead of the EDID from the display device. EDID features newer than HDMI 1.3 are removed when the display is read. This provides a general EDID which is compatible with more displays.

## DIP 2\* - Hot-Plug Detect

ON - HPD Pass-Through

- HPD follows upstream HPD towards the source. The HPD signal will reflect the connection status between the display device and the source device. If the source or display is temporarily disconnected then reconnected, there will be a delay of 20 - 30 seconds before the A/V content is restored to the display.

OFF (default) - HPD Always High

- The HPD signal remains high regardless of the downstream HPD state. If the source or display device does not properly handle HPD (no picture after connecting / reconnecting source or display), set this DIP switch to the OFF position.

## DIP 3\* - Supports DVI Connections

ON

- If a DVI connection is used, set DIP 3 to the ON position.

OFF (default)

- If HDMI is connected, set DIP 3 in the OFF position.

*\*DIP switch is only functional when DIP switch 1 is set to OFF.*

## NETWORK CABLE WIRING DIAGRAM

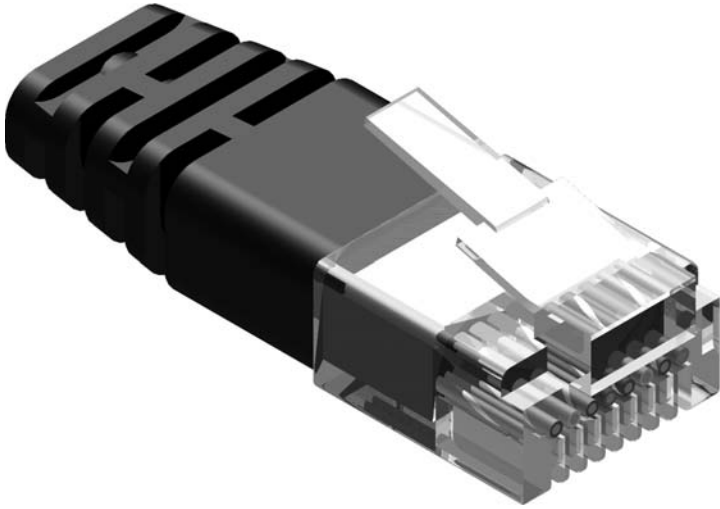

Gefen recommends the TIA/EIA-568-B wiring option. Please adhere to the table below when field terminating cable for use with Gefen products.

Pin	Color
1	Orange / White
2	Orange
3	Green / White
4	Blue
5	Blue / White
6	Green
7	Brown / White
8	Brown

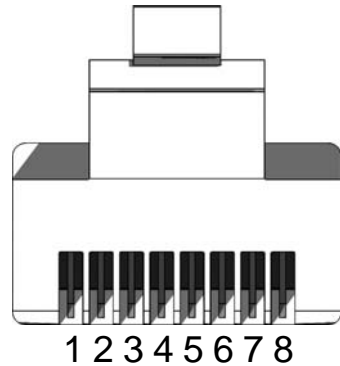

CAT-5, CAT-5e, and CAT-6 cabling comes in stranded and solid core types. Gefen recommends using solid core cabling. CAT-6 cable is also recommended.

It is recommended to use one continuous run from one end to the other. In some cases, connecting through a patch might not work.

## WALL MOUNTING INSTRUCTIONS

---

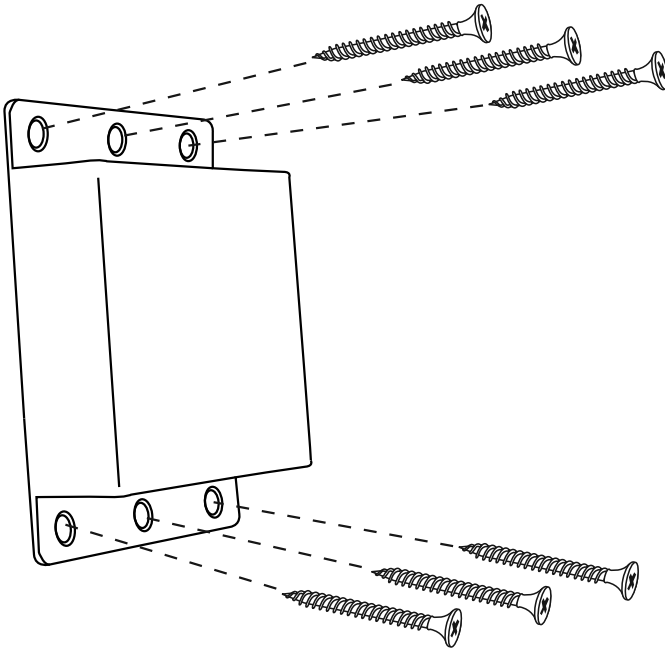

The GefenToolbox Extender for HDMI 3DTV should be mounted vertically on a wall or inside / outside a cabinet with wood / drywall screws as shown in the diagram above. There should be an inch or two of clearance between the edges of the unit and any walls or vertical surfaces to allow for enough clearance for connection and disconnection of the HDMI cable.

For installation on a drywall surface, use a #6 drywall screw. When installing, it is recommended to use the center hole on a stud.

## SPECIFICATIONS

---

Video Amplifier Bandwidth.....	225 MHz
Input Video Signal.....	1.2 V p-p
Input DDC Signal.....	5 V p-p (TTL)
Maximum Video Resolution.....	1080p, supports 3D HDMI signals
HDMI Input Connector.....	Type A 19-pin (F)
Link Connector.....	RJ-45 Shielded
Power Indicator.....	LED (red)
Dimensions.....	4.5" L x 3.25" W x 1.0" H
Power Supply.....	5 V DC
Power Consumption.....	10 W per unit (max.)
Operating Temperature .....	0 - 40 °C
Shipping Weight.....	2 lbs