

mitsubishi

CC-Link IE Controller Network Interface Board

User's Manual
(Hardware)

**Q80BD-J71GP21-SX
Q80BD-J71GP21S-SX**

Thank you for purchasing the Mitsubishi program logic controller MELSEC-Q series.

Prior to use, please read this and relevant manuals thoroughly to fully understand the product.

MELSEC-Q
Mitsubishi Programmable
Controller

MODEL	MNETG-B-SW1-H
MODEL CODE	13JY32
IB(NA)-0800386-D(0809)MEE	

● SAFETY PRECAUTIONS ●

(Be sure to read these instructions before using the product.)

Before using this product, read this manual and the relevant manuals introduced in this manual carefully and handle the product correctly with full attention to safety.

Note that these precautions apply only to this product. Refer to the user's manual of your CPU module for safety precautions on programmable controller systems. In this manual, the safety instructions are ranked as "DANGER" and "CAUTION".

 **DANGER**

Indicates that incorrect handling may cause hazardous conditions, resulting in death or severe injury.

 **CAUTION**

Indicates that incorrect handling may cause hazardous conditions, resulting in minor or moderate injury or property damage.

Note that failure to observe the  CAUTION level instructions may also lead to serious results depending on the circumstances.

Be sure to observe the instructions of both levels to ensure personal safety. Please store this manual in a safe place for future reference. This manual must be forwarded to the end user.

[Installation Precautions]

DANGER

- Do not touch connectors while current is applied.
Doing so may cause an electric shock or malfunction.
- Be sure to shut off all phases of the external power supply used by the system before installing the CC-Link IE Controller Network board to or removing it from the personal computer.
Failure to do so may cause an electric shock or damage to the product.

CAUTION

- Use the CC-Link IE Controller Network board in an environment that meets the general specifications provided in this manual. Using it in an environment that does not meet the general specifications may result in an electric shock, fire, malfunction, damage to or deterioration of the product.
- Securely insert the CC-Link IE Controller Network board into the PCI bus slot following the board installation instruction of the personal computer.
Incorrect insertion of the CC-Link IE Controller Network board may lead to a malfunction, failure or drop of the board.
- When installing the CC-Link IE Controller Network board, take care not to get injured by an implemented component or a surrounding member.
- Before handling the CC-Link IE Controller Network board, touch a grounded metal object to discharge the static electricity from the human body. Failure to do so may cause a failure or malfunction of the CC-Link IE Controller Network board.
- Handle the CC-Link IE Controller Network board in a place where static electricity will not be generated.
Failure to do so may cause a failure or malfunction.
- Do not directly touch a conductive part of the CC-Link IE Controller Network board.
Doing so may cause a failure or malfunction.
- Fix the CC-Link IE Controller Network board by tightening the board-fixing screws within the specified torque range.
Insufficient tightening may result in a malfunction.
- The CC-Link IE Controller Network board is included in an antistatic envelope.
When storing or transporting it, be sure to put it in the antistatic envelope.
Failure to do so may cause a failure or malfunction.
- Do not disassemble or remodel the CC-Link IE Controller Network board.
Doing so may result in a failure, malfunction, injuries and/or a fire.
- Do not drop or apply a strong impact to the CC-Link IE Controller Network board.
Doing so may cause a failure or malfunction.

[Wiring Precautions]

DANGER

- Be sure to shut off all phases of the external power supply used by the system before installing the CC-Link IE Controller Network board or starting wiring.
Failure to do so may cause an electric shock, damage to the product or malfunction.
- Before applying power to operate the system after installation of the CC-Link IE Controller Network board and wiring, be sure to put the cover on the module.
Failure to do so may result in an electric shock.

CAUTION

- Special skills and tools are required to connect the communication cable to the connector plug, which is an exclusive product.
When purchasing it, please consult your local Mitsubishi representative.
Incomplete connection can result in a short, fire or malfunction.
- Securely plug the communication cable to the connector of the CC-Link IE Controller Network board. Then, check for any incomplete connection.
Poor contact may cause an erroneous input or output.
- Place the communication cables and external power supply cable connected to the CC-Link IE Controller Network board in a duct or clamp them.
If not, dangling cables may swing or inadvertently be pulled, resulting in damage to the board or cables or malfunctions due to poor cable contact.
- When disconnecting the cable from the CC-Link IE Controller Network board, do not pull the cable part.
Pulling the cable that is still connected to the CC-Link IE Controller Network board may damage the board and/or cable, or cause a malfunction due to poor contact.
- Prevent foreign matter such as chips or wiring debris from getting into the personal computer.
Failure to do so can result in a fire, failure or malfunction.
- Verify the rated voltage and pin-out, and connect the external power supply cable properly.
Connecting a power supply with a different voltage rating, imperfect cable crimping or faulty wiring may cause a fire or failure.
- Use a specified tool for crimping of the cable and contacting pin. Imperfect crimping may cause a malfunction.
- Verify the pin-out and fully insert the crimped contacting pin into the connector. Imperfect insertion may cause a failure or malfunction.

[Wiring Precautions]

CAUTION

- Insert the wired external power supply cable into the external power supply cable connector until a click is heard.
Imperfect insertion may cause a failure or malfunction.
- Keep the external power supply cable away from the main circuit cable, power cables and/or the load cables for any other than programmable controllers. Ensure a distance of 100 mm (3.94 in.) between them. Failure to do so may result in a malfunction due to noise, surge or induction.
- Always ground the personal computer to the protective ground conductor.
Failure to do so may cause a malfunction

[Disposal Precautions]

CAUTION

- When disposing of this product, treat it as industrial waste.

Revisions

* The manual number is given on the bottom right of the cover.

Print Date	*Manual Number	Revision
Apr., 2007	IB(NA)-0800386-A	First edition
Oct., 2007	IB(NA)-0800386-B	<u>Correction</u> Chapter 5, Section 7.2, Chapter 8
Jan., 2008	IB (NA)-0800386-C	<u>Correction</u> SAFETY PRECAUTIONS, Manual, Chapter 1, Chapter 2, Chapter 3, Chapter 4, Chapter 5, Chapter 6, Chapter 7
Sep., 2008	IB (NA)-0800386-D	<u>Correction</u> Chapter 2

This manual confers no industrial property rights or any rights of any other kind, nor does it confer any patent licenses. Mitsubishi Electric Corporation cannot be held responsible for any problems involving industrial property rights which may occur as a result of using the contents noted in this manual.

CONTENTS

1. OVERVIEW.....	1
2. PERFORMANCE SPECIFICATIONS	2
3. HANDLING	4
3.1 Handling precautions	4
3.2 Installation environment.....	6
4. PART NAMES.....	7
5. EMC AND LOW VOLTAGE DIRECTIVE	10
5.1 Requirements for conformance to EMC Directive	10
5.1.1 Standards applicable to the EMC Directive.....	11
5.1.2 Installing devices in the control panel	12
5.1.3 Noise filter (power supply line filter)	14
5.2 Requirements for conformance to Low Voltage Directive	14
6. WIRING.....	15
6.1 Optical fiber cable	18
6.2 External power supply cable.....	19
7. INSTALLING SOFTWARE PACKAGES	21
7.1 Installation procedures	21
7.2 Icons to be Registered.....	23
8. EXTERNAL DIMENSIONS	24

Manual

The following is the manual relevant to this product.
Please purchase it if necessary.

Relevant Manuals

Manual Name	Manual Number (Model Code)
MELSECNET/G Network System Reference Manual (Controller Network) This manual explains the system configuration, performance specification, functions, handling and wiring instructions, and troubleshooting of the CC-Link IE Controller network system. (Sold separately)	SH-080668ENG (13JV16)
CC-Link IE Controller Network Interface Board User's Manual (For SW1DNC-MNETG-B) This manual explains the system configuration, software package installation and uninstallation, operating method for utilities, accessible ranges and devices, and troubleshooting of the CC-Link IE Controller Network board. (Sold separately)	SH-080691ENG (13JZ02)

1. OVERVIEW

This manual explains the handling of the Q80BD-J71GP21(S)-SX CC-Link IE Controller Network interface board (hereinafter referred to as CC-Link IE Controller Network board).

The CC-Link IE Controller Network board can be used as a control station or normal station in the CC-Link IE Controller network system.

The packing list of the CC-Link IE Controller Network board is given below.

Item	Quantity	
	Q80BD-J71GP21-SX	Q80BD-J71GP21S-SX
Q80BD-J71GP21-SX CC-Link IE Controller Network interface board	1	—
Q80BD-J71GP21S-SX CC-Link IE Controller Network interface board	—	1
Connector set (for external power supply cable)	—	1
CC-Link IE Controller Network Interface Board User's Manual (Hardware)	1	1
SW1DNC-MNETG-B CC-Link IE Controller Network software package (CD- ROM)*1	1	1
Software license agreement	1	1
Software registration card	1	1

*1 The CD-ROM contains the User's Manual in PDF format.

2. PERFORMANCE SPECIFICATIONS

Performance specifications of the CC-Link IE Controller Network board are shown below.

Q80BD-J71GP21-SX, Q80BD-J71GP21S-SX

Item		Specification	
		Q80BD-J71GP21-SX	Q80BD-J71GP21S-SX
Max. link points per network	LB	32K points (32768 points, 4K bytes)	
	LW	128K points (131072 points, 256K bytes)	
	LX	8K points (8192 points, 1K byte)	
	LY	8K points (8192 points, 1K byte)	
Max. link points per station	LB	16K points (16384 points, 2K bytes)	
	LW	16K points (16384 points, 32K bytes)	
	LX	8K points (8192 points, 1K byte)	
	LY	8K points (8192 points, 1K byte)	
Transient transmission capacity		Up to 1920 bytes	
Communications speed		1G bps	
Number of stations per network		120 stations (Control station: 1; Normal station: 119)	
Connection cable		Optical fiber cable (Multi-mode fiber)	
Overall cable distance		66000 m (When 120 stations are connected)	
Station-to-station distance	Min.	2 m	
	Max.	550 m (Core/clad = 50/125 (μ m))	
Max. number of networks		239	
Max. number of groups		32	
Transmission path		Duplex loop	
Communication method		Token ring method	
Synchronization method		Flag synchronization (Frame synchronization)	
Encoding method		8B10B	
Transfer format		Ethernet II	
Error control system		FCS (Frame Check Sequence, CRC32 of the frame, Ethernet-compliant)	
RAS functions		Loop back function by error detection and cable disconnection, System-down prevention by control station switching, Error detection by link special relays and link special registers, etc.	
Transient transmission		N: N communications	

Item	Specification	
	Q80BD-J71GP21-SX	Q80BD-J71GP21S-SX
Number of boards that can be installed	Up to 4*1	
Installation slot	PCI bus slot (Half size) or PCI-X bus slot (Half size)	
Occupied slots	1 slot	
External power supply*2	Voltage	20.4 V to 31.2 V DC
	Current	0.27 A
	Connector	Connector set (Accessory)
	Applicable cable size	0.50 to 1.25 mm ² [AWG20-16]
	Allowable momentary power failure time	(No external power supply) 1ms (level PS1)
	Noise durability	Noise voltage: 500vp-p Noise width: 1μs (By the noise simulator with noise frequency 25 to 60Hz)
PCI bus performance	Bus width: 32 bit Bus frequency: 33MHz Bus voltage: 5V or 3.3 V DC (Universal PCI compliance)	
5 V DC Internal current consumption	0.88 A	0.88 A
Weight	0.12 kg	0.14 kg

*1 This indicates the number of CC-Link IE Controller Network boards that can be installed to a personal computer, not including any other boards such as MELSECNET/H boards.

Note that it cannot exceed the number of physical PCI slots of the personal computer.

*2 Use the power complies with CLASS2.

3. HANDLING

This section explains precautions for handling and installation environment of the CC-Link IE Controller Network board.

3.1 Handling precautions

The following explains precautions for handling the CC-Link IE Controller Network board.



DANGER

- Do not touch connectors while current is applied. Doing so may cause an electric shock or malfunction.
- Be sure to shut off all phases of the external power supply used by the system before installing the CC-Link IE Controller Network board to or removing it from the personal computer. Failure to do so may cause an electric shock or damage to the product.



CAUTION

- Securely insert the CC-Link IE Controller Network board into the PCI bus slot following the board installation instruction of the personal computer.
Incorrect insertion of the CC-Link IE Controller Network board may lead to a malfunction, failure or drop of the board.
- When installing the CC-Link IE Controller Network board, take care not to get injured by an implemented component or a surrounding member.
- Before handling the CC-Link IE Controller Network board, touch a grounded metal object to discharge the static electricity from the human body.
Failure to do so may cause a failure or malfunction of the CC-Link IE Controller Network board.
- Handle the CC-Link IE Controller Network board in a place where static electricity will not be generated.
Failure to do so may cause a failure or malfunction.
- Do not directly touch a conductive part of the CC-Link IE Controller Network board.
Doing so may cause a failure or malfunction.
- Fix the CC-Link IE Controller Network board by tightening the board-fixing screws within the specified torque range.
Insufficient tightening may result in a malfunction.
- The CC-Link IE Controller Network board is included in an antistatic envelope.
When storing or transporting it, be sure to put it in the antistatic envelope.
Failure to do so may cause a failure or malfunction.
- Do not disassemble or remodel the CC-Link IE Controller Network board.
Doing so may result in a failure, malfunction, injuries and/or a fire.
- Do not drop or apply a strong impact to the CC-Link IE Controller Network board.
Doing so may cause a failure or malfunction.
- Prevent foreign matter such as chips or wiring debris from getting into the personal computer.
Failure to do so can result in a fire, failure or malfunction.
- When disposing of this product, treat it as industrial waste.

For the tightening torque of the CC-Link IE Controller Network board-fixing screws, refer to the manual supplied with the personal computer.

3.2 Installation environment

For installation of the personal computer in which the CC-Link IE Controller Network board is installed, refer to the manual for the personal computer.



CAUTION

- Use the CC-Link IE Controller Network board in an environment that meets the general specifications provided in this manual.
Using it in an environment that does not meet the general specifications may result in an electric shock, fire, malfunction, damage to or deterioration of the product.
- Always ground the personal computer to the protective ground conductor.
Failure to do so may cause a malfunction.

4. PART NAMES

This section explains each part name and setting of the CC-Link IE Controller Network board.

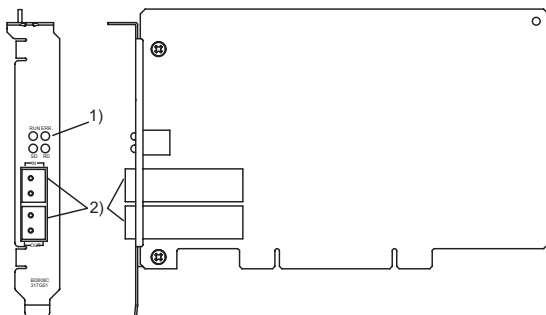

(1) Q80BD-J71GP21-SX

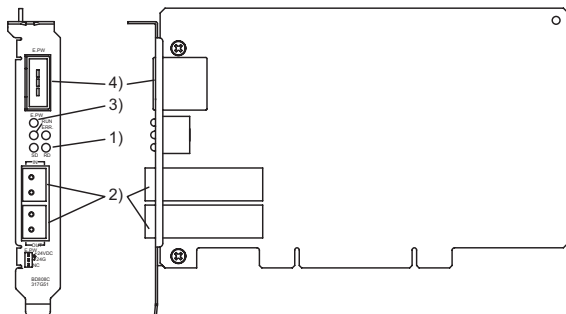

(2) Q80BD-J71GP21S-SX

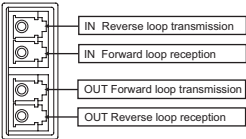

No.	Name	Description																																															
1)	Indicator LED RUN ERR. ○ ○ ○ ○ SD RD	<p>Indicates the operating status of the CC-Link IE Controller Network board.</p> <p>The display format has three types: normal mode, error mode and channel number confirmation.</p> <p>(1) Normal mode</p> <p>When the RUN LED is OFF or ON, the LED display becomes normal mode.</p> <p>If a communication error occurs in the mode, determine the error in Select station network device status display on the "CC-Link IE Controller Network diagnostics result" screen of the CC IE Control utility.</p> <p>For the Select station network device status display, refer to "CC-Link IE Controller Network Interface Board User's Manual (For SW1DNC-MNETG-B)".</p> <table border="1" data-bbox="324 441 912 714"> <thead> <tr> <th>LED name</th> <th>Status</th> <th>Description</th> </tr> </thead> <tbody> <tr> <td rowspan="2">RUN</td> <td>OFF</td> <td>A WDT error occurred or the board is being reset.</td> </tr> <tr> <td>ON</td> <td>In normal operation</td> </tr> <tr> <td rowspan="2">SD</td> <td>OFF</td> <td>Data has not been sent.</td> </tr> <tr> <td>ON</td> <td>During data transmission</td> </tr> <tr> <td rowspan="2">RD</td> <td>OFF</td> <td>Data has not been received.</td> </tr> <tr> <td>ON</td> <td>During data reception</td> </tr> <tr> <td rowspan="2">ERR.</td> <td>OFF</td> <td>No error</td> </tr> <tr> <td>ON</td> <td>Error</td> </tr> </tbody> </table> <p>(2) Error mode</p> <p>When the RUN LED is flashing, the LED display becomes error mode.</p> <p>If an error occurs in the mode, check the error description on the Event Viewer screen.</p> <table border="1" data-bbox="324 856 912 1156"> <thead> <tr> <th>LED name</th> <th>Status</th> <th>Description</th> </tr> </thead> <tbody> <tr> <td rowspan="3">RUN</td> <td>Flashing</td> <td>Indicates the display format is in error mode.</td> </tr> <tr> <td>ON</td> <td rowspan="2">Indicates the display format is not in error mode.</td> </tr> <tr> <td>OFF</td> </tr> <tr> <td rowspan="2">SD</td> <td>OFF</td> <td>—</td> </tr> <tr> <td>ON</td> <td>—</td> </tr> <tr> <td rowspan="2">RD</td> <td>OFF</td> <td>No driver response error</td> </tr> <tr> <td>ON</td> <td>A driver response error occurred.</td> </tr> <tr> <td rowspan="2">ERR.</td> <td>OFF</td> <td>No PCI bus error</td> </tr> <tr> <td>ON</td> <td>A PCI bus error occurred.</td> </tr> </tbody> </table> <p>(3) Channel number confirmation mode</p> <p>This mode is for checking the channel No. of each board. The LED displays the channel No. assigned to each board. For details, refer to "CC-Link IE Controller Network Interface Board User's Manual (For SW1DNC-MNETG-B)".</p>	LED name	Status	Description	RUN	OFF	A WDT error occurred or the board is being reset.	ON	In normal operation	SD	OFF	Data has not been sent.	ON	During data transmission	RD	OFF	Data has not been received.	ON	During data reception	ERR.	OFF	No error	ON	Error	LED name	Status	Description	RUN	Flashing	Indicates the display format is in error mode.	ON	Indicates the display format is not in error mode.	OFF	SD	OFF	—	ON	—	RD	OFF	No driver response error	ON	A driver response error occurred.	ERR.	OFF	No PCI bus error	ON	A PCI bus error occurred.
LED name	Status	Description																																															
RUN	OFF	A WDT error occurred or the board is being reset.																																															
	ON	In normal operation																																															
SD	OFF	Data has not been sent.																																															
	ON	During data transmission																																															
RD	OFF	Data has not been received.																																															
	ON	During data reception																																															
ERR.	OFF	No error																																															
	ON	Error																																															
LED name	Status	Description																																															
RUN	Flashing	Indicates the display format is in error mode.																																															
	ON	Indicates the display format is not in error mode.																																															
	OFF																																																
SD	OFF	—																																															
	ON	—																																															
RD	OFF	No driver response error																																															
	ON	A driver response error occurred.																																															
ERR.	OFF	No PCI bus error																																															
	ON	A PCI bus error occurred.																																															

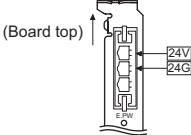
No.	Name	Description									
2)	Optical fiber cable connector	<p>Connector for connecting optical fiber cable (1) The cable terminal is as shown below.</p>  <p>(2) For wiring of an optical fiber cable, refer to "CC-Link IE Controller Network Interface Board User's Manual (For SW1DNC-MNETG-B)".</p>									
3)	External power supply LED E.PW 	<p>Indicates the status of external power supply.</p> <table border="1" data-bbox="363 457 951 588"> <thead> <tr> <th data-bbox="363 457 503 486">LED name</th> <th data-bbox="503 457 605 486">Status</th> <th data-bbox="605 457 951 486">Description</th> </tr> </thead> <tbody> <tr> <td data-bbox="363 486 503 535">E.PW</td> <td data-bbox="503 486 605 535">OFF</td> <td data-bbox="605 486 951 535">External power supply is not supplied.</td> </tr> <tr> <td data-bbox="363 535 503 588">E.PW</td> <td data-bbox="503 535 605 588">ON</td> <td data-bbox="605 535 951 588">External power supply is being supplied.</td> </tr> </tbody> </table>	LED name	Status	Description	E.PW	OFF	External power supply is not supplied.	E.PW	ON	External power supply is being supplied.
LED name	Status	Description									
E.PW	OFF	External power supply is not supplied.									
E.PW	ON	External power supply is being supplied.									
4)	External power supply cable connector	<p>Connector for connecting external power supply cable The cable terminal is as shown below.</p> 									

5. EMC AND LOW VOLTAGE DIRECTIVE

For the products sold in European countries, the conformance to the EMC Directive, which is one of the European Directives, has been a legal obligation since 1996. Also, conformance to the Low Voltage Directive, another European Directive, has been a legal obligation since 1997.

Manufacturers who recognize their products must conform to the EMC and Low Voltage Directives are required to declare that their products conform to these Directives and put a "CE mark" on their products.

5.1 Requirements for conformance to EMC Directive

The EMC Directive specifies that products placed on the market must "be so constructed that they do not cause excessive electromagnetic interference (emissions) and are not unduly affected by electromagnetic interference (immunity)". The applicable products are requested to meet these requirements.

The sections 5.1.1 through 5.1.3 summarize the precautions on conformance to the EMC Directive of the machinery constructed using the CC-Link IE Controller Network board.

The details of these precautions has been prepared based on the control requirements and the applicable standards. However, we will not assure that the overall machinery manufactured according to these details conforms to the above-mentioned directives.

The final decision on the method for the EMC Directive conformance and the application must be made by the manufacturer of the machinery.

5.1.1 Standards applicable to the EMC Directive

The standards applicable to the EMC Directive are listed below.
All test items were tested by installing each device on a personal computer bearing a CE certification logo.

Specification	Test item	Test details	Standard value
EN61131-2: 2003	EN61000-6-4 Radiated noise	Measures electromagnetic emissions from the product.	30M-230MHz QP: 30 dB μ V/m (30 m in measurement range) ^{*1} 230M-1000MHz QP: 37 dB μ V/m (30 m in measurement range) ^{*1}
	EN61000-6-4 Conducted noise	Measures electromagnetic emissions from the product to the power line.	150k-500kHz QP: 79 dB, Mean: 66 dB ^{*1} 500k-30MHz QP: 73 dB, Mean: 60 dB ^{*1}
	EN61000-4-2 Electrostatic immunity	Immunity test in which static electricity is applied to the cabinet of the equipment.	4 kV Contact discharge 8 kV Aerial discharge
	EN61000-4-4 Electrical fast transient/ burst immunity	Immunity test in which a burst noise is applied to a power line and signal line.	Power line: 2 kV Data communication: 1 kV Digital/Analog I/O (shielded): 1 kV
	EN61000-4-3 Radiated electromagnetic field immunity (AM modulation)	Immunity test in which a field is irradiated to the product.	10 V/m, 26-1000 MHz, 80%AM modulation@1 kHz
	EN61000-4-6 Conducted disturbances immunity	Immunity test in which a high frequency noise is applied to a power line and signal line.	3 V
	EN61000-4-5 Surge immunity	Immunity test in which a lightning surge is applied to a power line and signal line.	Power line: 2 kV (CM), 1 kV (DM) Data communication (shielded): 1 kV (CM) Digital/Analog I/O (shielded): 1 kV (CM)

*1 QP: Quasi-peak value, Mean: Mean value

5.1.2 Installing devices in the control panel

Installing devices in the control panel has a considerable effect, not only securing safety but also shielding the noise generated from the personal computer in the control panel.

(1) Control panel

- (a) Use a conductive control panel.
- (b) When attaching the control panel's top plate or base plate, mask painting and weld so that good surface contact can be made between the panel and plate.
- (c) To ensure good electrical contact with the control panel, mask the paint on the installation bolts of the inner plate in the control panel so that contact between surfaces can be ensured over the widest possible area.
- (d) Ground the control panel with a thick wire so that a low impedance connection to ground can be ensured even at high frequencies.
- (e) Holes made in the control panel must be 10 cm (3.94 in.) diameter or less. If the holes are 10 cm (3.94 in.) or larger, radio frequency noise may be emitted.

In addition, because radio waves leak through a clearance between the control panel door and the main unit, reduce the clearance as much as practicable. The leakage of radio waves can be suppressed by the direct application of an EMI gasket on the paint surface.

Maker name	Series type
KITAGAWA INDUSTRIES CO., LTD.	US series
ZIPPERTUBING (JAPAN) LTD.	71TS series
SEIWA ELECTRIC MFG CO., LTD.	E02S□□□A

Our tests have been carried out on a panel having the damping characteristics of 37 dB max. and 30 dB mean (measured by 3 m method with 30 to 300MHz).

(2) Connection of power and ground cable

The power supply cable and ground cable for a personal computer should be laid out as follows:

- (a) Provide a grounding point near the power supply of personal computer. Ground the FG (frame ground) terminal of the personal computer and the SLD (shield) terminal of the CC-Link IE Controller Network board with the thickest and shortest grounding wire (wire for grounding) possible (about 30 cm (11.81 in.) or less in length). Since the FG and SLD terminals function to ground the noise generated in the personal computer, it is necessary to ensure the lowest possible impedance.

As the wires are used to relieve the noise, the wire itself contains a large amount of noise and thus short wiring prevents from functioning as an antenna.

- (b) Twist the ground cable leading to the ground point with the power supply cable. By twisting it with the ground cable, the noise leaking from the power supply cable may be grounded at a higher rate. However, twisting the power supply cable with the ground cable may not be necessary if a noise filter is installed on the power supply cable.

5.1.3 Noise filter (power supply line filter)

A noise filter is a component which has an effect on conducted noise. It is not required to fit the noise filter to the power supply line, but fitting it can further suppress noise. (The noise filter has the effect of reducing conducted noise of 10MHz or less.)

The precautions required when installing a noise filter are described below.

- (1) Do not bundle the wires on the input side and output side of the noise filter.

When they are bundled, the output side noise will induct into the input side wires.

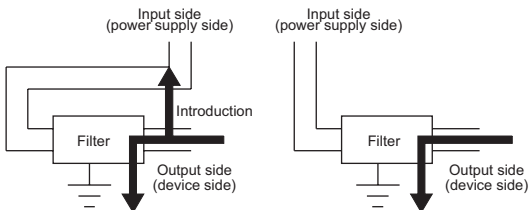

- (a) The noise will induct into input side when the input and output wires are bundled. (b) Separate the input and output wires.

- (2) Ground the ground terminal of the noise filter to the control panel using as short wiring as possible (about 10 cm (3.94 in.)).

Remarks

Reference noise filters are shown below.

Noise filter type	Maker name	Rated current	Rated voltage
FN343-3/01	SCHAFFNER	3 A	250 V
FN660-6/06		6 A	
ZHC2203-11	TDK	3 A	



5.2 Requirements for conformance to Low Voltage Directive

The CC-Link IE Controller Network board is out of the requirement for conformance to the Low Voltage Directive, since it does not use the power supply in the range of 50 to 1000V AC and 75 to 1500V DC.

6. WIRING

This section explains precautions for connecting cables to the CC-Link IE Controller Network board.

(1) Precautions for general wiring

 DANGER	<ul style="list-style-type: none">● Be sure to shut off all phases of the external power supply used by the system before installing the CC-Link IE Controller Network board or starting wiring. Failure to do so may cause an electric shock, damage to the product or malfunction.● Before applying power to operate the system after installation of the CC-Link IE Controller Network board and wiring, be sure to put the cover on the module. Failure to do so may result in an electric shock.
 CAUTION	<ul style="list-style-type: none">● When disconnecting the cable from the CC-Link IE Controller Network board, do not pull the cable part. Pulling the cable that is still connected to the CC-Link IE Controller Network board may damage the board and/or cable, or cause a malfunction due to poor contact.● Prevent foreign matter such as chips or wiring debris from getting into the personal computer. Failure to do so can result in a fire, failure or malfunction.● Always ground the personal computer to the protective ground conductor. Failure to do so may cause a malfunction.

(2) Precautions for communication cable wiring



CAUTION

- Special skills and tools are required to connect the communication cable to the connector plug, which is an exclusive product.
When purchasing it, please consult your local Mitsubishi representative.
Incomplete connection can result in a short, fire or malfunction.
- Securely plug the communication cable to the connector of the CC-Link IE Controller Network board. Then, check for any incomplete connection.
Poor contact may cause an erroneous input or output.
- Place the communication cables connected to the CC-Link IE Controller Network board in a duct or clamp them.
If not, dangling cables may swing or inadvertently be pulled, resulting in damage to the board or cables or malfunctions due to poor contact.

Remarks

For optical fiber cables, refer to the "MELSECNET/G Network System Reference Manual (Controller Network)".

(3) Precautions for external power supply cable wiring



CAUTION

- Verify the rated voltage and pin-out, and connect the external power supply cable properly. Connecting a power supply with a different voltage rating, imperfect cable crimping or faulty wiring may cause a fire or failure.
- Use a specified tool for crimping of the cable and contacting pin. Imperfect crimping may cause a malfunction.
- Verify the pin-out and fully insert the crimped contacting pin into the connector. Imperfect insertion may cause a failure or malfunction.
- Insert the wired external power supply cable into the external power supply cable connector until a click is heard. Imperfect insertion may cause a failure or malfunction.
- Keep the external power supply cable away from the main circuit cable, power cables and/or the load cables for any other than programmable controllers. Ensure a distance of 100 mm (3.94 in.) between them. Failure to do so may result in a malfunction due to noise, surge or induction.
- Place the external power supply cables connected to the CC-Link IE Controller Network board in a duct or clamp them.
If not, dangling cables may swing or inadvertently be pulled, resulting in damage to the board or cables or malfunctions due to poor contact.

Remarks

For details of the wiring method, refer to "CC-Link IE Controller Network Interface Board User's Manual (For SW1DNC-MNETG-B)".

6.1 Optical fiber cable

The following explains precautions for connecting the optical fiber cables with the Q80BD-J71GP21-SX and Q80BD-J71GP21S-SX.

(1) Precautions for connection

- (a) Use the dedicated optical fiber cable shown below for the controller network system.

Type	Model name (maker)
Multi-mode fiber (GI)	QG series (Mitsubishi electric system & service Co., Ltd.)

- (b) When connecting an optical fiber cable to the Q80BD-J71GP21-SX and Q80BD-J71GP21S-SX, the cable bend radius is restricted.
For details, check the specifications of the cable used.
- (c) When laying the optical fiber cables, do not touch the fiber cores of the cable-side and board-side connectors, and protect them from dirt and dust.
If oil from the hand, dirt or dust is attached to the core, it can increase transmission loss, causing a problem in data link.
- (d) When connecting or disconnecting an optical fiber cable, hold the connector part of the cable.
- (e) Make a full connection between the cable-side and board-side connectors until a "click" can be heard.
- (f) When installing the Q80BD-J71GP21-SX or Q80BD-J71GP21S-SX to the personal computer, secure a space of around 10 mm (0.39 in.) to the right and left of the optical connector. Depending on the adjacent boards and installing slot position, connecting/disconnecting the optical cable may be difficult. In this case, use the following dedicated tool.

Model name	Maker
SCT-SLM	Mitsubishi electric system & service Co., Ltd.

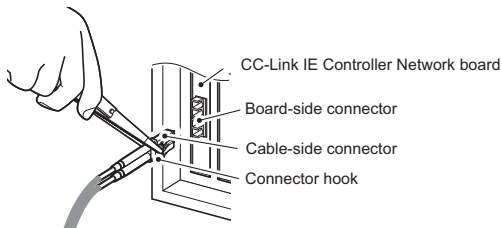

6.2 External power supply cable

This section explains the method for connecting external power supply cable to the Q80BD-J71GP21S-SX.

(1) Parts and tools required for external power supply cable

The following parts and tools are required for making external power supply cable.

(a) Connector set (accessories)

Check that the following parts are included with the attached connector set.

Type	Model name	Applicable wire size	Quantity
Connector	1-178288-3	—	1
Contact	175218-2	AWG#20-16	3 (Spare 1)

(b) Cable

Use an external power supply cable with heat-resistant vinyl sheath of 0.5 to 1.25 mm² [AWG 20 to 16].

(c) Tool

Use the following specified crimp tools.

Model	Applicable wire size	Inquiry
91558-1	AWG#20-16	Tyco Electronics
1762956-1		

(2) Making external power supply cable

(a) Crimping a contacting pin

Using a crimp tool, crimp the cable and contacting pin.

Set the contacting pin and cable in the grooves of the crimp tool, squeeze the handle, and make them stick together tightly. For details of the crimp, refer to the instruction of the tool. A strip length of the cable should be 5 to 7 mm (1/5 to 2/7 in.)

(b) Check for a crimp

Check if the cable (including a part of the sheath) is evenly crimped to the contacting pin.

If the cable part is crimped but not the sheath part or the cable is stuck out, the cable cut or a malfunction may result.

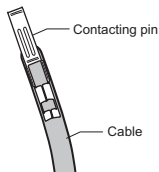

- (c) Connecting to the connector
According to the following pin-out, fully insert the crimped cable to the connector until a click is heard.

Pin No.	Description
1	24V
2	24G
3	Open

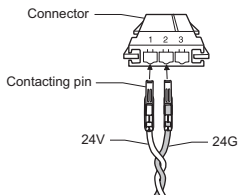

- (3) Connecting external power supply cable to the board
Properly insert the wired external power supply cable to the external power supply cable connector of the Q80BD-J71GP21S-SX until a click is heard.
Keep the cable away from the main circuit cable, power cables and/or the load cables for any other than programmable controllers.
Ensure a distance of 100 mm (3.94 in.) between them.

POINT	
-------	--

Be sure to twist the external power supply cable.

7. INSTALLING SOFTWARE PACKAGES

This chapter explains about installing the software packages and icons to be registered.

For the uninstallation method, refer to "CC-Link IE Controller Network Interface Board User's Manual (For SW1DNC-MNETG-B)".

7.1 Installation procedures

For details of the installation procedure, refer to "CC-Link IE Controller Network Interface Board User's Manual (For SW1DNC-MNETG-B)".

POINT
(1) Multi-processor personal computers cannot be used because the driver does not support them. For details of the operating environment, refer to "CC-Link IE Controller Network Interface Board User's Manual (For SW1DNC-MNETG-B)".
(2) Log on as a user having administrator authority.
(3) Cancel all applications registered in Startup and install the driver after restarting Windows®.
(4) Make sure to close other applications running on Windows® (including resident software such as antivirus software) before installation.
(5) If the installation failed, uninstall the software package if possible.
(6) When reinstalling the software package, do so after uninstalling the current software package and restarting the personal computer.

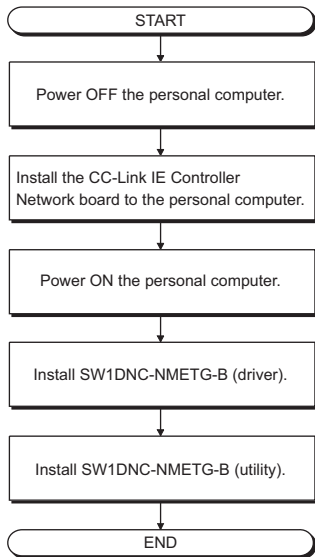



7.2 Icons to be Registered

After installing the software packages, the icons shown below are registered in [MELSEC], selected from [Start] - [Program].

Remarks

When using Windows® XP Professional/Windows® XP Home Edition/Windows Vista®*1, the following icons are registered in [Start] - [All Programs] - [MELSEC].

Icon	Utility name	Description
	CC IE Control utility	Starts CC IE Control utility.
	Device Monitor Utility	Starts Device monitor utility.
	MELSEC Data Link Function HELP	Starts HELP for the data link function.

- *1 Generic term for Microsoft® Windows Vista® Home Basic Operating System, Microsoft® Windows Vista® Home Premium Operating System, Microsoft® Windows Vista® Business Operating System, Microsoft® Windows Vista® Ultimate Operating System, and Microsoft® Windows Vista® Enterprise Operating System.

8. EXTERNAL DIMENSIONS

(1) Q80BD-J71GP21-SX

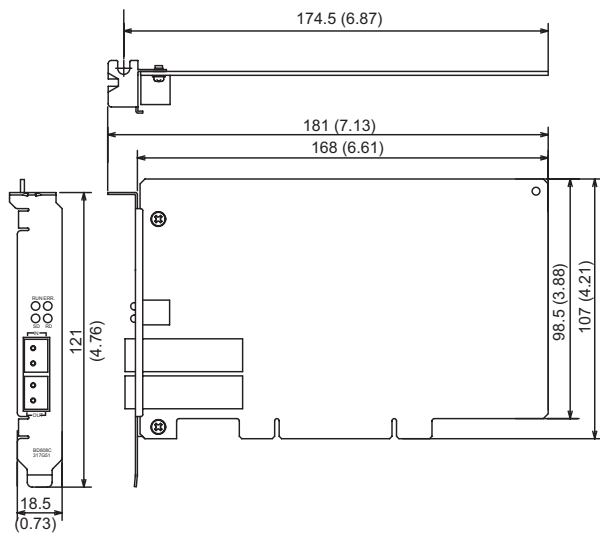

(Unit: mm (inch))

(2) Q80BD-J71GP21S-SX

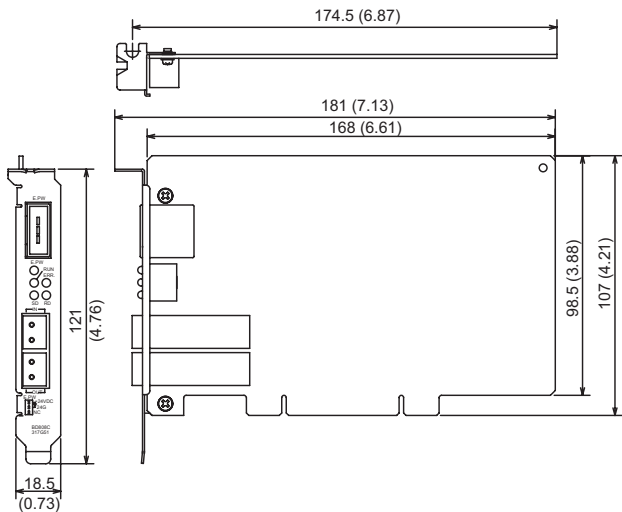

(Unit: mm (inch))

Microsoft and Windows are registered trademarks of Microsoft Corporation in the United States and other countries.

Ethernet is a registered trademark of Xerox.co.ltd in the United States.

Other company names and product names used in this document are trademarks or registered trademarks of respective companies.

Warranty

Mitsubishi will not be held liable for damage caused by factors found not to be the cause of Mitsubishi; machine damage or lost profits caused by faults in the Mitsubishi products; damage, secondary damage, accident compensation caused by special factors unpredictable by Mitsubishi; damages to products other than Mitsubishi products; and to other duties.

For safe use

- This product has been manufactured as a general-purpose part for general industries, and has not been designed or manufactured to be incorporated in a device or system used in purposes related to human life.
- Before using the product for special purposes such as nuclear power, electric power, aerospace, medicine or passenger movement vehicles, consult with Mitsubishi.
- This product has been manufactured under strict quality control. However, when installing the product where major accidents or losses could occur if the product fails, install appropriate backup or failsafe functions in the system.

Country/Region	Sales office/Tel	Country/Region	Sales office/Tel
U.S.A	Mitsubishi Electric Automation Inc. 500 Corporate Woods Parkway Vernon Hills, IL 60061 Tel : +1-847-478-2100	Hong Kong	Ryoden Automation Ltd. 10th Floor, Manulife Tower, 169 Electric Road, North Point, HongKong Tel : +852-2887-8870
Brazil	MELCO-TEC Rep. Com.e Assessoria Tecnica Ltda. Rua Correia Dias, 184, Edificio Paraiso Trade Center-8 andar Paraiso, Sao Paulo, SP Brazil Tel : +55-11-5908-8331	China	Ryoden Automation Shanghai Ltd. 3F Block5 Building Automation Instrumentation Plaza 103 Cao Bao Rd. Shanghai 200233 China Tel : +86-21-6120-0808
Germany	Mitsubishi Electric Europe B.V. German Branch Gothaer Strasse 8 D-40880 Ratingen, GERMANY Tel : +49-2102-486-0	Taiwan	Setsuyo Enterprise Co., Ltd. 6F., No.105 Wu-Kung 3rd.RD., Wu-Ku Hsiang, Taipei Hsine, Taiwan Tel : +886-2-2299-2499
U.K	Mitsubishi Electric Europe B.V. UK Branch Travellers Lane, Hatfield, Herts., AL10 8XB,UK Tel : +44-1707-276100	Korea	HAN NEUNG TECHNO CO.,LTD. 1F Dong Seo Game Channel Bldg., 660-11, Deungchon-dong Kangsec-ku, Seoul, Korea Tel : +82-2-3660-9552
Italy	Mitsubishi Electric Europe B.V. Italian Branch Centro Dir. Colleoni, Pal. Perseo-Ing.r 2 Via Paracelso 12, 20041 Agrate B., Milano, Italy Tel : +39-039-6053344	Singapore	Mitsubishi Electric Asia Pte, Ltd. 307 Alexandra Road #05-01/02, Mitsubishi Electric Building Singapore 159943 Tel : +65-6473-2308
Spain	Mitsubishi Electric Europe B.V. Spanish Branch Carretera de Rubi 76-80 08190 Sant Cugat del Valles, Barcelona, Spain Tel : +34-93-565-3131	Thailand	F. A. Tech Co.,Ltd. 898/28,29,30 S.V.City Building,Office Tower 2, Floor 17-18 Rama 3 Road, Bangkokpongpan, Yannawa, Bangkok 10120 Tel : +66-2-682-6522
France	Mitsubishi Electric Europe B.V. French Branch 25 Boulevard des Bouvets, F-92741 Nanterre Cedex, France TEL: +33-1-5568-5568	Indonesia	P.T. Autoteknindo SUMBER MAKMUR Jl. Muara Karang Selatan Block a Utara No.1 Kav. No.11 Kawasan Industri/ Pergudangan Jakarta - Utara 14440 Tel : +62-21-663-0833
South Africa	Circuit Breaker Industries LTD. Tripswitch Drive, Elandsfontein Gauteng, South Africa Tel : +27-11-928-2000	India	Messung Systems Put.Ltd. Electronic Sadan NO:111 Unit No15, M.I.D.C BHOSARI,PUNE-411026, India Tel : +91-20-712-2807
		Australia	Mitsubishi Electric Australia Pty. Ltd. 348 Victoria Road, PostalBag, No 2, Rydalmere, N.S.W 2116, Australia Tel : +61-2-9684-7777



MITSUBISHI ELECTRIC CORPORATION

HEAD OFFICE : 1-8-12, OFFICE TOWER 2 14F HARUMI CHUO-KU 104-6212, JAPAN
NAGOYA WORKS : 1-14, YADA-MINAMI 5-CHOME, HIGASHI-KU, NAGOYA, JAPAN

When exported from Japan, this manual does not require application to the Ministry of Economy, Trade and Industry for service transaction permission.

Specifications subject to change without notice.
Printed in Japan on recycled paper.