



HIRSCHMANN

A **BELDEN** BRAND

User Manual

Installation

Open Dual-Band Industrial Access-Point / Client / Access-Bridge

OpenBAT-Family: BAT-R

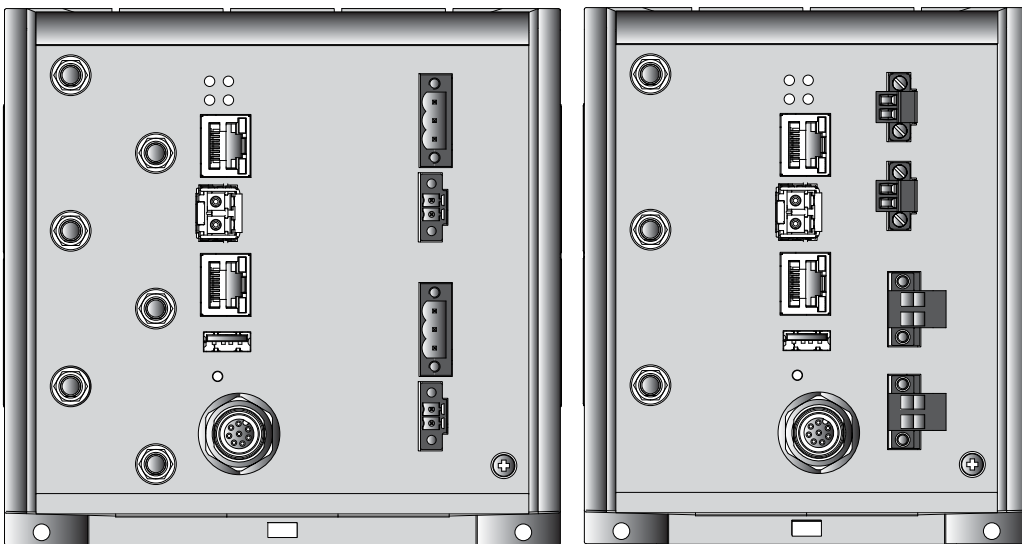

The naming of copyrighted trademarks in this manual, even when not specially indicated, should not be taken to mean that these names may be considered as free in the sense of the trademark and tradename protection law and hence that they may be freely used by anyone.

© 2014 Hirschmann Automation and Control GmbH

Manuals and software are protected by copyright. All rights reserved. The copying, reproduction, translation, conversion into any electronic medium or machine scannable form is not permitted, either in whole or in part. An exception is the preparation of a backup copy of the software for your own use. For devices with embedded software, the end-user license agreement on the enclosed CD/DVD applies.

The performance features described here are binding only if they have been expressly agreed when the contract was made. This document was produced by Hirschmann Automation and Control GmbH according to the best of the company's knowledge. Hirschmann reserves the right to change the contents of this document without prior notice. Hirschmann can give no guarantee in respect of the correctness or accuracy of the information in this document.

Hirschmann can accept no responsibility for damages, resulting from the use of the network components or the associated operating software. In addition, we refer to the conditions of use specified in the license contract.

You can get the latest version of this manual on the Internet at the Hirschmann product site (www.hirschmann.com).

Printed in Germany
Hirschmann Automation and Control GmbH
Stuttgarter Str. 45-51
72654 Neckartenzlingen
Germany
Tel.: +49 1805 141538

Contents

Safety instructions	5
About this manual	19
Key	19
1 Description	20
1.1 General description	20
1.2 Device name and product code	21
1.3 Combination options	25
1.4 Device view	27
1.5 Power supply	29
1.5.1 Working voltage with the characteristic value C	29
1.5.2 Working voltage with the characteristic value K	29
1.5.3 Working voltage with the characteristic value P	29
1.5.4 Working voltage with the characteristic value W	29
1.6 Ethernet ports	30
1.6.1 Gigabit combo port	30
1.6.2 10/100/1000 Mbit/s twisted-pair connection (optional)	32
1.7 Connections for antennas	32
1.8 Display elements	33
1.8.1 Meaning of the LEDs	33
1.8.2 Device state	33
1.8.3 Port state	34
1.9 Management interfaces	35
1.9.1 V.24 interface (external management)	35
1.9.2 USB interface	37
1.10 Signal contact	37
1.11 Operation element (reset button)	37
2 Installation	38
2.1 Overview	38
2.2 Unpacking and checking the content of the package	38
2.3 Installing and grounding the device	39
2.3.1 Installing the device onto the DIN rail	40
2.3.2 Mounting on a vertical flat surface	40
2.3.3 Grounding the device	41

2.4	Installing an SFP transceiver (optional)	41
2.5	Installing the antennas	42
2.6	Connecting the terminal blocks (optional)	43
2.6.1	Working voltage with the characteristic value C	43
2.6.2	Working voltage with the characteristic value K	44
2.6.3	Working voltage with the characteristic value W	45
2.6.4	Signal contact	46
2.7	Operating the device	46
2.7.1	Connecting the power supply through a terminal block	46
2.7.2	Connecting the power supply through PoE	47
2.8	Connecting data cables	47
2.8.1	Gigabit combo port	47
2.8.2	10/100/1000 Mbit/s twisted-pair connection (optional)	47
3	Configuration	48
3.1	Basic set-up	48
3.2	Configuring antennas	48
4	Operation	51
4.1	Restarting the device (soft reset/reboot)	51
4.2	Resetting the configuration (hard reset)	51
4.3	Loading the configuration	52
5	Maintenance and service	53
6	Disassembly	54
6.1	Removing the device	54
6.2	Removing an SFP transceiver (optional)	55
7	Technical data	56
A	Further Support	75

Safety instructions

■ General safety instructions

You operate this device with electricity. The proper and safe operation of this device depends on proper handling during transportation, proper storage and assembly, and conscientious operation and maintenance procedures. Improper use of this device is associated with the risk of personal injury or property damage.

- Read this documentation as well as the safety instructions and warnings before connecting any cables.
- Never start operation with damaged components.
- The device does not contain any service components. If the device is not functioning correctly, or if it is damaged, switch off the voltage supply and return the device to Hirschmann for inspection.

WARNING

UNCONTROLLED MACHINE ACTIONS

To avoid uncontrolled machine actions caused by data loss, configure all the data transmission devices individually.

Before you start any machine which is controlled via data transmission, be sure to complete the configuration of all data transmission devices.

Failure to follow these instructions can result in death, serious injury, or equipment damage.

■ Qualification requirements for personnel

- Only allow qualified personnel to work on the device.

Qualified personnel have the following characteristics:

- ▶ Qualified personnel are properly trained. Training as well as practical knowledge and experience make up their qualifications. This is the prerequisite for grounding and labeling circuits, devices, and systems in accordance with current standards in safety technology.
- ▶ Qualified personnel are aware of the dangers that exist in their work.
- ▶ Qualified personnel are familiar with appropriate measures against these hazards in order to reduce the risk for themselves and others.
- ▶ Qualified personnel receive training on a regular basis.

■ **Intended usage**

- Use the product solely for the application cases described in the Hirschmann product information, including this manual.
- Operate the product solely according to the technical specifications.
[See “Technical data” on page 56.](#)
- Connect to the product solely components suitable for the requirements of the specific application case.

■ **Grounding the device**

Grounding the device is by means of a separate ground connection on the device.

- Ground the device before connecting any other cables.
- Disconnect the grounding solely after disconnecting all other cables.

The overall shield of a connected shielded twisted-pair cable is connected to the ground connector on the front panel as a conductor.

■ **Working voltage**

The working voltage is electrically isolated from the housing.

- Connect solely an working voltage that corresponds to the type plate of your device.
- Solely for device variants featuring working voltage with the characteristic value K:

[See “Device name and product code” on page 21.](#)

Every time you connect the electrical conductors, make sure that the following requirements are met:

- ▶ The power supply conforms to overvoltage category I or II.
- ▶ The voltage supply has an easily accessible disconnecting device (e.g. a switch or a plug). This disconnecting device is clearly identified. So in the case of an emergency, it is clear which disconnecting device belongs to which line.
- ▶ The electrical wires are voltage-free.
- ▶ Supply with AC voltage:
A fuse is located in the outer conductor of the power supply. The neutral conductor is on ground potential. Otherwise, a fuse is also located in the neutral conductor.
Regarding the properties of this fuse: [See “General technical data” on page 56.](#)
- ▶ Supply with DC voltage:
A fuse suitable for DC voltage is located in the plus conductor of the power supply.
The minus conductor is on ground potential. Otherwise, a fuse is also located in the minus conductor.
Regarding the properties of this fuse: [See “General technical data” on page 56.](#)

- ▶ Supply with AC voltage:
The wire diameter of the power supply cable is at least 0.75 mm² (North America: AWG18) on the working voltage input.
- ▶ Supply with DC voltage:
The wire diameter of the power supply cable is at least 1 mm² (North America: AWG16) on the working voltage input.
- ▶ The cross-section of the protective conductor is the same size as or bigger than the cross-section of the power supply cables.
- ▶ The power supply cables used are permitted for the temperature range required by the use case.
- ▶ Relevant for North America:
The power cords are suitable for ambient air temperatures of at least 167 °F (75 °C). The power cord wires are made of copper.

Start connecting the electrical wires solely if **all** the above requirements are fulfilled.

- Solely for device variants featuring working voltage with the characteristic value C or W:

[See “Device name and product code” on page 21.](#)

Every time you connect the electrical conductors, make sure that the following requirements are met:

- ▶ The power supply conforms to overvoltage category I or II.
- ▶ The power supply is Class 2 compliant.
- ▶ The working voltage inputs are designed for operation with safety extra-low voltage. Connect solely SELV circuits with voltage restrictions in line with IEC/EN 60950-1 to the working voltage connections.
- ▶ The voltage supply has an easily accessible disconnecting device (e.g. a switch or a plug). This disconnecting device is clearly identified. So in the case of an emergency, it is clear which disconnecting device belongs to which line.
- ▶ The electrical wires are voltage-free.
- ▶ A fuse suitable for DC voltage is located in the plus conductor of the power supply.
The minus conductor is on ground potential. Otherwise, a fuse is also located in the minus conductor.
Regarding the properties of this fuse: [See “General technical data” on page 56.](#)
- ▶ The wire diameter of the power supply cable is at least 1 mm² (North America: AWG16) on the working voltage input.
- ▶ The cross-section of the protective conductor is the same size as or bigger than the cross-section of the power supply cables.

- ▶ The power supply cables used are permitted for the temperature range required by the use case.
- ▶ Relevant for North America:
The power cords are suitable for ambient air temperatures of at least 167 °F (75 °C). The power cord wires are made of copper.

Start connecting the electrical wires solely if **all** the above requirements are fulfilled.

- Use undamaged parts.
- Internal fuses are triggered solely in the case of a detected error in the device. In case of damage or malfunction of the device, turn off the working voltage and return the device to the plant for inspection.
- Only switch on the operating voltage for the device when the following requirements are fulfilled:
 - ▶ The housing is closed
 - ▶ The terminal blocks are wired correctly
 - ▶ The terminal blocks for the operating supply are connected
- For power supply connections with protective conductor connection: First connect the protective conductor before connecting the wires for the working voltage.
If your device comprises a 2nd working voltage connection of this type: First connect the protective conductor before connecting the wires for the working voltages.

■ Housing

Only technicians authorized by the manufacturer are permitted to open the housing.

- Never insert pointed objects (narrow screwdrivers, wires, etc.) into the device or into the connection terminals for electric conductors. Do not touch the connection terminals.
- Keep the ventilation slits free to ensure good air circulation.
- Install the device in the vertical position.
- At ambient temperatures > 140 °F (60 °C):
The surfaces of the device housing may become hot. Avoid touching the device while it is operating.

■ Installation site requirements

- Applies to device variants with the characteristic value B and D for mounting (indoor service access area, and outdoors):
[See “Device name and product code” on page 21.](#)
Install this device solely in a switch cabinet or in an operating site with restricted access, to which maintenance staff have exclusive access.

- Verify that there is at least 4 in (10 cm) of space above and below the device.
- Verify that there is at least 0.8 in (2 cm) of space on the right and left sides of the device.
- Install the device in a fire protected enclosure according to EN 60950-1.

In the following exceptional cases, you do **not** require a fire-protected shell:

- ▶ You are supplying voltage to the device only via PoE.
- ▶ You are supplying only 24 V to the device and are using a fuse.
Regarding the properties of this fuse: [See “General technical data” on page 56.](#)

■ **Lightning protection**

- See the information in the “WLAN Outdoor Guide”, chapter “Lightening and Surge Voltage Protection”.
- Install over voltage protector devices on every outdoor Ethernet cable.
- Protect antennas installed outside with lightening protection devices (e.g. lightening conductors).
- Take lightening protection measures which mitigate the effects of lightning strikes.
- ▶ The installation of the device occurs in accordance with valid standards (such as VDE 0185 and IEC 62305), and in accordance with the lightening protection procedures recognized and proven for the application and the environment.

■ **Operating conditions**

- When installing external antennas, adhere to the regulations of the country in which you are operating the WLAN device.
- Solely connect components to the device which meet the IP degree of protection requirements for the application case.
- Solely connect components to the device which are suitable for the ambient air temperature of the application case.

■ **National and international safety regulations**

- Verify that the electrical installation meets local or nationally applicable safety regulations.

■ **CE marking**

The labeled devices comply with the regulations contained in the following European directive(s):

2011/65/EU (RoHS)

Directive of the European Parliament and of the Council on the restriction of the use of certain hazardous substances in electrical and electronic equipment.

1999/5/EC (R&TTE)

Directive of the European Parliament and the council for radio installations and telecommunication systems and for the mutual recognition of their conformity.

This directive also contains the goals of directive 2004/108/EC of the European Parliament and the council for standardizing the regulations of member states relating to electromagnetic compatibility, and directive 2006/95/EC of the European Parliament and the council for standardizing the regulations of member states relating to electrical equipment to be used within specific voltage ranges, but without applying the lower voltage threshold.

 This product may be operated in all EU (European Union) countries under the condition that it has been configured correctly. In accordance with the above-named EU directive(s), the EU conformity declaration will be at the disposal of the relevant authorities at the following address:

Hirschmann Automation and Control GmbH
Stuttgarter Str. 45-51
72654 Neckartenzlingen
Germany
Tel.: +49 1805 141538

The product can be used in living areas (living area, place of business, small business) and in industrial areas.

■ E marking

The labeled devices comply with the regulations contained in the following European directive(s):

Rule No. 10 of the Economic Commission for Europe (ECE): Devices with an approval are labeled with the E type-approval mark.

The optical transceivers M-SFP-SX/LC EEC und M-SFP-LX/LC EEC can be used (relevant for devices with certificates characteristic value M). Devices featuring working voltage with the characteristic value C are not specified for operation during the motor start phase.

■ **LED or laser components**

LED or LASER components according to IEC 60825-1 (2007):
CLASS 1 LASER PRODUCT
CLASS 1 LED PRODUCT

■ **Relevant for use in Ex Zone 2 according to ATEX 95 (European directive 94/9/EC):**

In Ex zone 2, solely the devices with a corresponding label may be operated.

When operating the BAT-R types with the characteristic value G for approvals 1 (ATEX zone 2), the following applies:

- Never use the working voltage with the characteristic value K in Ex zone 2.



II 3 G

Ex nA IIC T4 Gc

-40 °F ... +158 °F (-40 °C ... +70 °C) for characteristic value T and E for temperature range
+32 °F ... +140 °F (0 °C ... +60 °C) for characteristic value S for

temperature range

DEKRA 13ATEX0027 X

Temperature code T4	Ambient -40 °C ... +158 °F (-40 °C ... +70 °C; characteristic value T and E for temperature range) Ambient +32 °F ... +140 °F (0 °C ... +60 °C; characteristic value S for temperature range)
List of standards	EN 60079-0:2009 EN 60079-15:2010

DO NOT OPEN THE DEVICE WHEN IT IS CONNECTED TO ELECTRICITY.

THE USB CONNECTOR MUST NOT BE USED WHEN THE DEVICE IS OPERATED IN EXPLOSIVE HAZARDOUS LOCATIONS.

Special conditions for safe use

- For characteristic value C and W for working voltage:
Take appropriate protective measures to prevent the voltage caused by transients from exceeding 119 V on the working voltage connection.
- When the temperature under rated conditions exceeds 158 °F (70 °C) on the cable or at conduit entry point, or 176 °F (80 °C) at the branching point of the conductors, take measures that the temperature specification of the selected cable is in compliance with the actual measured temperature values.
- The modules shall be installed in a suitable enclosure in accordance with EN 60079-15 providing a degree of protection of at least IP54 according to EN 60529, taking into account the environmental conditions under which the equipment will be used.

■ Relevant for use in explosion hazard areas (Hazardous Locations, Class I, Division 2):

In Ex zone 2, solely the devices with a corresponding label may be operated in explosion hazard areas Class I, Division 2.

When operating the BAT-R types in explosion hazard areas Class I, Division 2, the following applies:

Class I, Div. 2 Groups A, B, C and D



Temperature code T4	Ambient: -40 °F ... +158 °F (-40 °C ... +70 °C; for characteristic value T and E for temperature range) Ambient: +32 °F ... +140 °F (0 °C ... +60 °C; for characteristic value S for temperature range)
List of standards	FM3600, FM3611

DO NOT OPEN THE DEVICE WHEN ENERGIZED.



Ordinary Location, Non-Hazardous Area,
non-explosive atmosphere



Explosive Atmosphere
Class I, Div. 2 Groups A, B, C, D
Hazardous Location

Relay contacts. Equipment with nonincendive field wiring parameters. Polarity is not relevant.

THE RELAY TERMINALS ARE DEPENDENT UPON THE FOLLOWING ENTITY PARAMETERS:

$$U_i = 30 \text{ V} \quad I_i = 90 \text{ mA} \quad L_i = 1 \mu\text{H} \quad C_i = 2 \text{ nF}$$

WARNING! The USB is for temporary connection only, for maintenance use. Do not use, connect or disconnect unless the area is known to be non-hazardous. Connection or disconnection in an explosive atmosphere could result in an explosion!

- Power Supply unit type W: 18 V DC – 32 V DC
- Power Supply unit type C: 18 V DC – 60 V DC
- Power Supply unit type K: 88 V AC – 265 V AC or 48 V DC – 320 V DC

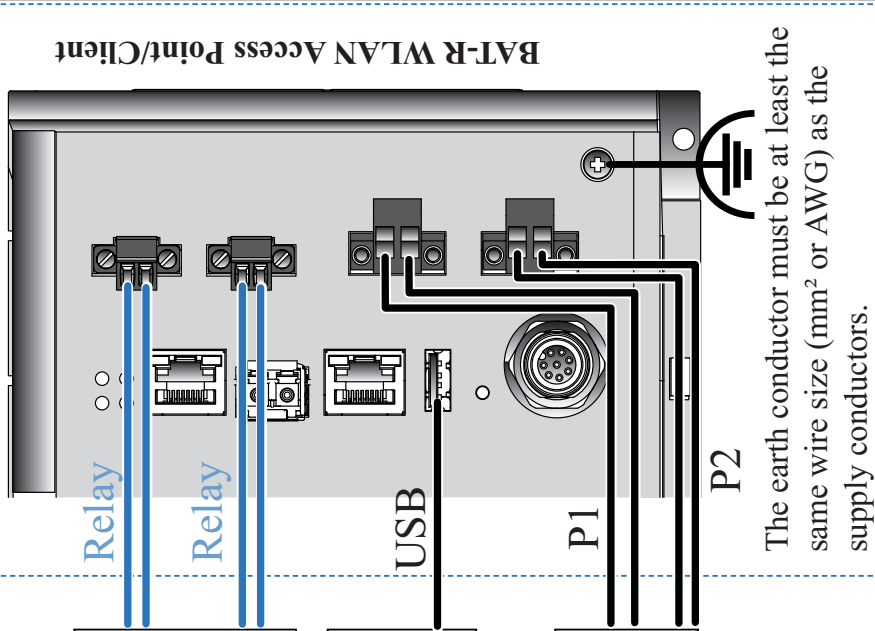

The earth conductor must be at least the same wire size (mm² or AWG) as the supply conductors.



Control Drawing for BAT-R devices according to Class I, Div. 2 Haz. Locations

Rev.: 1 Document No.: 000170957DNR

Page 1 of 2

Temperature Code: T4

Ambient Temperature rating:

Ta : 0 °C to +60°C for “S” temperature types

Ta: -40°C to +70°C for “T” or “E” temperature types

(Refer to the temperature code of the type designation on the device.)

**For Use in Hazardous Locations Class I, Division 2 Groups A, B, C, D:
Only allowed for BAT-R model No's. which are individually labelled “FOR USE IN HAZARDOUS LOCATIONS”**

Nonincendive field wiring circuits must be wired in accordance with the National Electrical Code (NEC), NFPA 70 , article 501.

WARNING – EXPLOSION HAZARD – SUBSTITUTION OF ANY COMPONENTS MAY IMPAIR SUITABILITY FOR HAZARDOUS LOCATIONS OR EXPLOSIVE ATMOSPHERES.

WARNING – EXPLOSION HAZARD – DO NOT DISCONNECT EQUIPMENT UNLESS POWER HAS BEEN SWITCHED OFF OR THE AREA IS KNOWN TO BE NONHAZARDOUS.

Notes:

The nonincendive field wiring circuit concept allows interconnection of nonincendive field wiring apparatus and associated nonincendive field wiring apparatus using any of the wiring methods permitted for unclassified locations when certain parametric conditions are met.

Capacity: $C_a \text{ or } C_0 \geq C_i + C_{\text{Cable}}$;

Inductivity: $L_a \text{ or } L_0 \geq L_i + L_{\text{Cable}}$



Control Drawing for BAT-R devices according to Class I, Div. 2 Haz. Locations

Rev.: 1

Document No.: 000170957DNR

Page 2 of 2

■ **FCC note:**

This device complies with part 15 of the FCC rules.

Operation is subject to the following two conditions:

- ▶ This device may not cause harmful interference, and
- ▶ This device must accept any interference received, including interference that may cause undesired operation.

This equipment has been tested and found to comply with the limits for a Class B digital device, pursuant to part 15 of the FCC Rules. These limits are designed to provide reasonable protection against harmful interference in a residential installation. This equipment generates, uses and can radiate radio frequency energy and, if not installed and used in accordance with the instructions, may cause harmful interference to radio communications. However, there is no guarantee that interference will not occur in a particular installation. If this equipment does cause harmful interference to radio or television reception, which can be determined by turning the equipment off and on, the user is encouraged to try to correct the interference by one or more of the following measures:

- Reorient or relocate the receiving antenna.
 - Increase the separation between the equipment and receiver.
 - Connect the equipment into an outlet on a circuit different from that to which the receiver is connected.
 - Consult the dealer or an experienced radio/TV technician for help.
- Changes or modifications not expressly approved by the holder of the certificate could void the user's authority to operate this equipment.

Important note:

The following section applies to BAT-R variants with the characteristic value US (USA/Canada) for country approvals which are labeled as follows:

Contains Transmitter Module

FCC ID: U99EWLAN1

IC: 4019A-EWLAN1

This equipment complies with FCC and IC RSS-102 radiation exposure limits set forth for an uncontrolled environment. This equipment should be installed and operated with minimum distance of 19.7 inches (50 cm) (related to a 9 dBi antenna) between the radiator and your body.

The antenna used for this transmitter must not be co-located with any other transmitters within a host device, except in accordance with FCC multi-transmitter product procedures.

This transmitter is restricted to indoor use only within the 5.15-5.25 GHz band to reduce potential for harmful interference to co-channel mobile satellite systems.

This Class B digital apparatus complies with Canadian ICES-003.
Cet appareil numérique de la classe B est conforme à la norme NMB-003 du Canada.

To reduce potential radio interference to other users, the antenna type and its gain should be so chosen that the equivalent isotropically radiated power (EIRP) is not more than that permitted for successful communication.

This device has been designed to operate with the antennas listed below in point-to-multipoint systems, and having a maximum gain of 9 dBi:

Antennas operating with this device model:	Permitted band of operation		
	2.4 GHz band	5.15 GHz ... 5.25 GHz band	5.725 GHz ... 5.825 GHz band
BAT-ANT-RSMA-2AGN-R ⁽¹⁾	Yes	Yes	Yes
BAT-ANT-N-3AGN-IP67	Yes	Yes	Yes
BAT-ANT-N-MiMoDB-5N-IP65	Yes	Yes	Yes
BAT-ANT-N-MiMo5-9N-IP65	No	Yes	Yes
BAT-ANT-N-8G-DS-IP65	Yes	No	No

Antennas not included in this list are strictly prohibited for use with this device. The required antenna impedance is 50 ohms.

Note (1): When using 3 antennas type BAT-ANT-RSMA-2AGN-R, you must align each antenna in another spatial direction (x-y-z) so that one antenna is arranged vertically to the device and the other two antennas are arranged at right angles to each other.

Important note:

The following section applies to BAT-R variants with the characteristic value US (USA/Canada) for country approvals which are labeled as follows:

Contains Transmitter Module
FCC ID: U99EWLAN2
IC: 4019A-EWLAN2

This equipment complies with FCC and IC RSS-102 radiation exposure limits set forth for an uncontrolled environment. This equipment should be installed and operated with minimum distance of 19.7 inches (50 cm) (related to a 18 dBi antenna) between the radiator and your body.

The antenna used for this transmitter must not be co-located with any other transmitters within a host device, except in accordance with FCC multi-transmitter product procedures.

This transmitter is restricted to indoor use only within the 5.15-5.25 GHz band to reduce potential for harmful interference to co-channel mobile satellite systems.

This Class B digital apparatus complies with Canadian ICES-003.
Cet appareil numérique de la classe B est conforme à la norme NMB-003 du Canada.

To reduce potential radio interference to other users, the antenna type and its gain should be so chosen that the equivalent isotropically radiated power (EIRP) is not more than that permitted for successful communication.

This device has been designed to operate with the antennas listed below having a maximum gain of 18 dBi:

Antennas operating with this device model:	Permitted band of operation		
	2.4 GHz band	5.15 GHz ... 5.25 GHz band	5.725 GHz ... 5.825 GHz band
BAT-ANT-RSMA-2AGN-R ⁽¹⁾	Yes	Yes	Yes
BAT-ANT-N-3AGN-IP67	Yes	Yes	Yes
BAT-ANT-N-MiMoDB-5N-IP65	Yes	Yes	Yes
BAT-ANT-N-MiMo5-9N-IP65	No	Yes	Yes
BAT-ANT-N-8G-DS-IP65	Yes	No	No
BAT-ANT-N-MiMo-18N-IP65 ⁽²⁾	No	No	Yes

Antennas not included in this list are strictly prohibited for use with this device. The required antenna impedance is 50 ohms.

Note (1): When using 3 antennas type BAT-ANT-RSMA-2AGN-R, you must align each antenna in another spatial direction (x-y-z) so that one antenna is arranged vertically to the device and the other two antennas are arranged at right angles to each other.

Connect the BAT-ANT-N-MiMo-18N-IP65 to the WLAN module as follows:

- Connect the antenna port "Ver" with the WLAN antenna port 1.
- Connect the antenna port "+45°" with the WLAN antenna port 2.
- Connect the antenna port "-45°" with the WLAN antenna port 3.

- Connect the BAT-ANT-N-MiMo-18N-IP65 in this way exclusively. Other connection combinations are not permitted.

■ Japan note

This note applies to BAT-R variants with the characteristic value JP (Japan) for country approvals which are labeled as follows:

- ▶ "Contains MIC ID: 204-310014"
- ▶ "5GHz band: この製品は屋内においてのみ使用可能です"

Devices with the characteristic value JP for country approvals are suitable for usage with the following antennas:

Antennas for operation with this device:	Permissible frequency bands	
	2.4 GHz band	5 GHz band
BAT-ANT-N-3AGN-IP67	Yes	Yes
BAT-ANT-RSMA-2AGN-R	Yes	Yes
BAT-ANT-6ABG-IP65	Yes	Yes
BAT-ANT-N-MiMoDB-5N-IP65	Yes	Yes
BAT-ANT-N-8G-DS-IP65	Yes	No
BAT-ANT-N-9A-DS-IP65	No	Yes
BAT-ANT-N-6G-IP65	Yes	No
BAT-ANT-N-5A-IP65	No	Yes
BAT-ANT-N-MiMo-9N-IP65	No	Yes

The usage of antennas missing in this list is prohibited. The 5 GHz band is restricted to indoor usage.

■ **Recycling note**

After usage, this device must be disposed of properly as electronic waste, in accordance with the current disposal regulations of your county, state, and country.

About this manual

The “Installation” user manual contains a device description, safety instructions, a description of the display, and the other information that you need to install the device.

You will find additional documents as PDF files on the enclosed CD/DVD.

The Industrial HiVision network management software provides you with additional options for smooth configuration and monitoring:

- ▶ ActiveX control for SCADA integration
- ▶ Auto-topology discovery
- ▶ Browser interface
- ▶ Client/server structure
- ▶ Event handling
- ▶ Event log
- ▶ Simultaneous configuration of multiple devices
- ▶ Graphical user interface with network layout
- ▶ SNMP/OPC gateway

Key

The symbols used in this manual have the following meanings:

▶	Listing
□	Work step
■	Subheading

1 Description

1.1 General description

The devices allow you to set up WLANs (Wireless Local Area Networks) in a local network. In contrast to a conventional network connection through copper cables and fiber optic cables, some of the communication is performed by means of a radio link.

The devices allow you to install a new LAN or expand an existing LAN. Thanks to their high level of flexibility, the OpenBAT device is suitable for a wide range of applications. Anywhere that high bandwidths, stable operation and network security is required, WLAN with these devices provides the ideal solution.

The devices are dual-band industrial high-performance wireless LAN access points or clients complying with IEEE 802.11a/b/g/h and 802.11n. They provide a high radio output with a bandwidth of up to 450 Mbit/s. The devices support MIMO (Multiple Input Multiple Output) and Multipath. The bandwidth is increased by using the multipath transmission by means of reflections. Each WLAN module has 3 antennas for sending and receiving, to ensure stable network coverage with few shadow areas.

You can choose from between a wide range of variants. You have the option to set up your device individually based on different criteria:

- ▶ Access point or client
- ▶ Number of WLAN modules
- ▶ Number of ports
- ▶ Working voltage range
- ▶ Installation area
- ▶ Software options
- ▶ Temperature range

The BAT-R devices are designed for the special requirements of industrial automation. They meet the relevant industry standards, provide very high operational reliability, even under extreme conditions, and also long-term reliability and flexibility.

The devices work without a fan.

The following installation options are available:

- ▶ simply snapping them onto a DIN rail
- ▶ Mounting on a vertical flat surface

You have the option of choosing various media to connect to the terminal devices and other network components:

- ▶ twisted pair cable
- ▶ multimode F/O
- ▶ singlemode F/O

There are convenient options for managing the device. Administer your devices via:

- ▶ a Web browser
- ▶ SSH
- ▶ Telnet
- ▶ HiDiscovery (Software for putting the device into operation)
- ▶ management software (e.g. Industrial HiVision, LANconfig/LANmonitor)
- ▶ a V.24 interface (locally on the device)

The devices provide you with a large range of functions, which the manuals for the operating software inform you about. You will find these manuals as PDF files on the enclosed CD/DVD, or you can download them from the Internet on the Hirschmann product pages (www.hirschmann.com). The Hirschmann network components help you ensure continuous communication across all levels of the company.

1.2 Device name and product code

The device name corresponds to the product code. The product code is made up of characteristics with defined positions. The characteristic values stand for specific product properties.

Item	Product characteristic	Characteristic value	Description
1 ... 5	Devices of the OpenBAT family	BAT-R	DIN Rail housing
6 ... 7	Country approvals	AU	Australia
		CN	China
		EU	Europe (CE)
		JP	Japan
		SG	Singapore
		US	United States/Canada (FCC/ICC)
8	Slot 1	W	WLAN module
9	Slot 2	W	WLAN module
		9	Not assembled
10	Slot 3	9	Not assembled
11	Access point or client	A	Access Point
		C	Client

Table 1: Device name and product code

Item	Product characteristic	Characteristic value	Description
12	Working voltage 1	C	Rated voltage range DC 24 V ... 48 V
		K	Rated voltage range DC 60 V ... 250 V
		P ^a	Rated voltage range AC 110 V ... 230 V, 50 Hz ... 60 Hz
		W	Nominal voltage DC 24 V
13	Working voltage 2	C	Rated voltage range DC 24 V ... 48 V
		K	Rated voltage range DC 60 V ... 250 V
			Rated voltage range AC 110 V ... 230 V, 50 Hz ... 60 Hz
		W	Nominal voltage DC 24 V
		9	Not present
14	Approvals 1	F	Class I, Division 2 Groups A, B, C, D Hazardous Locations
		G	ATEX Zone 2
		I	Substation applications (EN 61850)
		K	Rail applications (EN 50155)
		M	Motor vehicles applications (E type approval indicator, ECE No. 10)
		9	No additional approvals
15	Approvals 2	H	WLAN module version for high-gain antennas
		M	Motor vehicles applications (E type approval indicator, ECE No. 10)
		9	No additional approvals
16	Mounting	A	Indoor operator access area ^b
		B	Indoor service access area ^c
17 ... 18	Ethernet port 1	O7	Combo port – you can use these ports for alternative purposes: <ul style="list-style-type: none"> ▶ alternatively, depending on device variant <ul style="list-style-type: none"> ▶ Power supply unit characteristic value C and K: RJ45 socket for 10/100/1000 Mbit/s twisted-pair port ▶ Power supply unit characteristic value P and W: RJ45 socket for 10/100/1000 Mbit/s PoE PD port ▶ SFP slot for 1000 Mbit/s F/O port

Table 1: Device name and product code

Item	Product characteristic	Characteristic value	Description
19 ... 20	Ethernet port 2	T1	RJ45 socket for 10/100/1000 Mbit/s twisted-pair port
		99	Not present
21	Temperature range	E	Extended with conformal coating -40 °F ... +158 °F (-40 °C ... +70 °C)
		K	Extended with conformal coating and approvals 1, characteristic value K, railway applications: -40 °C ... +55 °C
		S	Standard 0 °C ... +60 °C (+32 °F ... +140 °F)
		T	Extended -40 °F ... +158 °F (-40 °C ... +70 °C)
22	Software option 1	A	VPN-5
		B	VPN-50
		C	VPN-100
		9	Not present
23	Software option 2	9	Not present
24	Software option 3	D	Public Spot
		9	Not present
25	Configuration	Z	Equipment package
		9	Hirschmann standard
26	Device model	H	Hirschmann standard

Table 1: Device name and product code

- a. The power supply for this type is exclusively via the LAN as a Powered Device according to Power over Ethernet (PoE) 802.3af
- b. Location for which one of the following conditions apply when one operates it correctly:
 - The area is accessible without tools.
 - The person responsible for the area has provided access for the operator intentionally.
 - The operator knows of the access possibilities, regardless of whether they need a tool.
- c. Location outside the operator area to which the service personnel has access, even when the device is switched on.

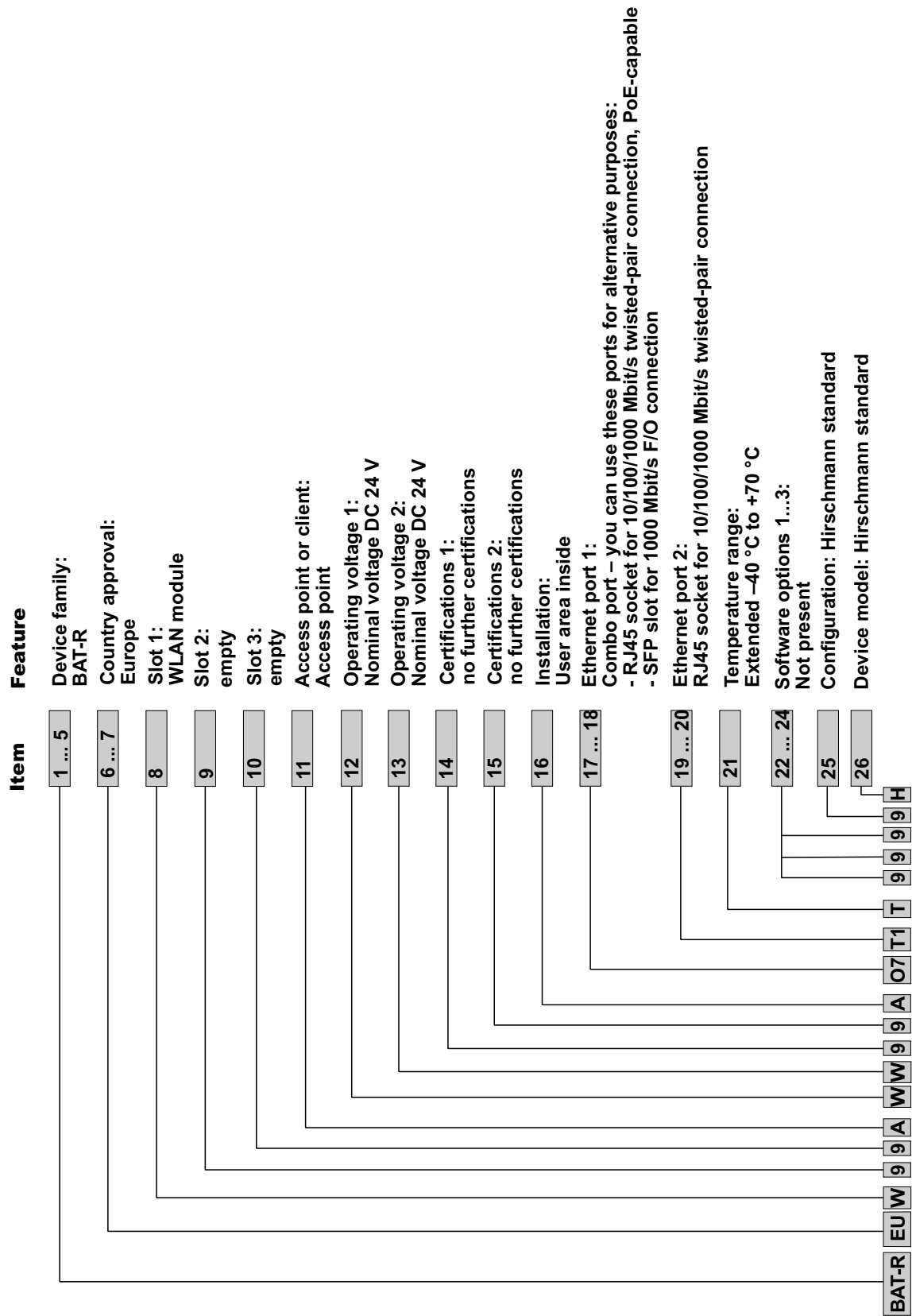

Figure 1: Example of a device name:
BAT-REUW99AWW99AO7T1T999

1.3 Combination options

Product characteristic	Country approvals		Slots 1 to 3	Access point or client	Working voltage 1 and 2	Approvals 1:	Approvals 2:	Mounting	Ethernet port 1	Ethernet port 2	Temperature range	Software options 1 to 3			Configuration	Device model
	Model											23	24	25		
Item	1 ... 5	6 ... 7	8 ... 10	11	12 ... 13	14	15	16	17 ... 18	19 ... 20	21	22	23	24	25	26
Attribute values	BAT-R	AU; CN; EU; JP; SG	W99	A; C	WW	F; G; I; M; 9	9	A; B	O7	T1; 99	E; S; T	A; B; C; 9	9	D; 9	Z; 9	H
	BAT-R	US	W99	A; C	WW	F; I; M; 9	H; 9	A; B	O7	T1; 99	E; S; T	A; B; C; 9	9	D; 9	Z; 9	H
	BAT-R	AU; CN; EU; JP; SG	W99	A; C	WW	K	M; 9	A; B	O7	T1; 99	E	A; B; C; 9	9	D; 9	Z; 9	H
	BAT-R	US	W99	A; C	WW	K	H; M; 9	A; B	O7	T1; 99	E	A; B; C; 9	9	D; 9	Z; 9	H
	BAT-R	AU; CN; EU; JP; SG	WW9; W99	A; C	CC	F; G; I; M; 9	9	A; B	O7	T1; 99	E; S; T	A; B; C; 9	9	D; 9	Z; 9	H
	BAT-R	US	WW9; W99	A; C	CC	F; I; M; 9	H; 9	A; B	O7	T1; 99	E; S; T	A; B; C; 9	9	D; 9	Z; 9	H
	BAT-R	AU; CN; EU; JP; SG	WW9; W99	A; C	KC; KK; K9	F; G; I; 9	9	B	O7	T1; 99	E; S; T	A; B; C; 9	9	D; 9	Z; 9	H
	BAT-R	US	WW9; W99	A; C	KC; KK; K9	F; I; 9	H; 9	B	O7	T1; 99	E; S; T	A; B; C; 9	9	D; 9	Z; 9	H

Table 2: Combination options of the BAT-R device variants

Product characteristic	Model	Country approvals	Slots 1 to 3	Access point or client	Working voltage 1 and 2	Approvals 1:	Approvals 2:	Mounting	Ethernet port 1	Ethernet port 2	Temperature range	Software options 1 to 3	Configuration	Device model		
Item	1 ... 5	6 ... 7	8 ... 10	11	12 ... 13	14	15	16	17 ... 18	19 ... 20	21	22	23	24	25	26
	BAT-R	AU; CN; EU; JP; SG	W99	A; C	P9	F; G; I; M; 9	9	A; B	O7	T1; 99	E; S; T	A; B; C; 9 9	D; 9	Z; 9	H	
	BAT-R	US	W99	A; C	P9	F; I; M; 9	H; 9	A; B	O7	T1; 99	E; S; T	A; B; C; 9 9	D; 9	Z; 9	H	
	BAT-R	AU; EU; JP; SG; US	W99	A; C	P9	K	H; 9	A; B	O7	T1; 99	E	A; B; C; 9 9	D; 9	Z; 9	H	
	BAT-R	EU	WW9	A; C	WW	K	9	A; B	O7	T1; 99	K	A; B; C; 9 9	D; 9	Z; 9	H	

Table 2: Combination options of the BAT-R device variants

1.4 Device view

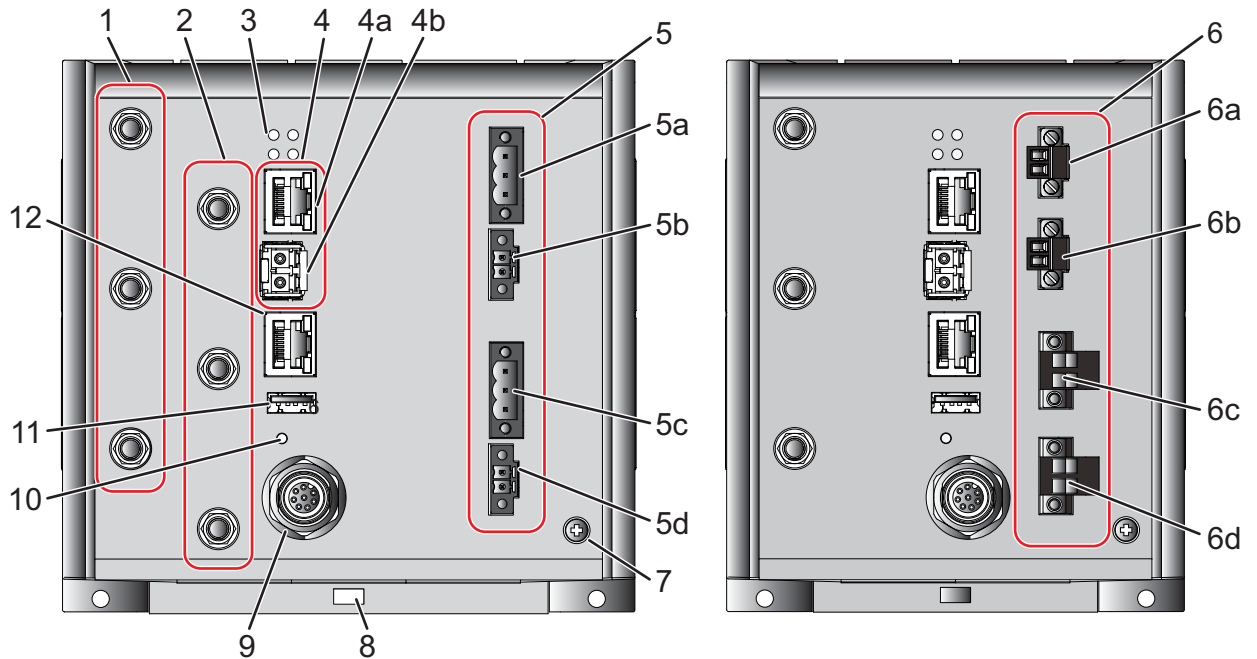

1	WLAN module 1:	3 × reverse SMA connection
2	Optional:	WLAN module 2: 3 × reverse SMA connection
3	LED display elements for device status	
4	Ethernet port 1 Combo port – you can use these ports for alternative purposes:	
4a	alternatively, depending on device variant	
	▶	Power supply unit characteristic value C and K: RJ45 socket for 10/100/1000 Mbit/s twisted-pair port
	▶	Power supply unit characteristic value P and W: RJ45 socket for 10/100/1000 Mbit/s PoE PD port
4b	SFP slot for 1000 Mbit/s F/O port	

Table 3: Front view of the BAT-R-devices:

Left: device variants featuring working voltage with the characteristic value C or K

Right: device variants featuring working voltage with the characteristic value W

Not shown: device variants featuring working voltage with the characteristic value P9

5	Device variants featuring working voltage with the characteristic value C or K	
5a	Power supply connection 1	
	<ul style="list-style-type: none"> ▶ Working voltage with the characteristic value C 2-pin terminal block ▶ Working voltage with the characteristic value K 3-pin terminal block 	
5b	Connection for signal contact 1	
5c	Optional:	Power supply connection 2
		<ul style="list-style-type: none"> ▶ Working voltage with the characteristic value C 2-pin terminal block ▶ Working voltage with the characteristic value K 3-pin terminal block
5d	For devices with 2 power supply connections:	Connection for signal contact 2
6	Device variants featuring working voltage with the characteristic value W	
6a	Connection for signal contact 1 2-pin terminal block	
6b	Connection for signal contact 2 2-pin terminal block	
6c	Power supply connection 1 2-pin terminal block	
6d	Power supply connection 2 2-pin terminal block	
7	Connection for protective grounding	
8	Locking gate for removing the device	
9	V.24 interface	
10	Reset button	
11	USB interface	
12	Optional:	RJ45 socket for 10/100/1000 Mbit/s twisted-pair port Ethernet port 2

Table 3: *Front view of the BAT-R-devices:*

Left: device variants featuring working voltage with the characteristic value C or K

Right: device variants featuring working voltage with the characteristic value W

Not shown: device variants featuring working voltage with the characteristic value P9

1.5 Power supply

Solely for device variants featuring working voltage with the characteristic value C, K or W:

For redundant and failure-resistant power supply, you have the option of connecting multiple voltage sources in any combination at the same time. The device selects the used voltage source automatically.

Switching to a redundant voltage source possibly occurs with a short delay. If the voltage source currently active fails and another voltage source takes over the supply of voltage to the device, the device reboots if necessary to activate the redundant power supply.

1.5.1 Working voltage with the characteristic value C

A 2-pin terminal block is available to supply the device.

You will find further information under [“Working voltage with the characteristic value C” on page 43](#).

1.5.2 Working voltage with the characteristic value K

A 3-pin terminal block is available to supply the device.

You will find further information under [“Working voltage with the characteristic value K” on page 44](#).

1.5.3 Working voltage with the characteristic value P

Your device is a PD (powered device). PSE (power sourcing equipment) connected via a twisted pair cable on the PoE PD port serves as the PoE power supply voltage. The PoE power supply means that no separate power supply is required for your device.

Note: With working voltage with the characteristic value P, the signal contact is omitted.

You will find further information under [“10/100/1000 Mbit/s PoE PD port” on page 30](#).

1.5.4 Working voltage with the characteristic value W

You have the following options to supply your device with voltage:

■ Power supply through a terminal block

A 2-pin terminal block is available to supply the device.

You will find further information under [“Working voltage with the characteristic value W” on page 45](#).

■ Power supply through PoE

Note: If your device has two WLAN modules, it is not possible to supply power via PoE.

Your device is a PD (powered device). PSE (power sourcing equipment) connected via a twisted pair cable on the PoE PD port serves as the PoE power supply voltage. The PoE power supply means that no separate power supply is required for your device.

You will find further information under [“10/100/1000 Mbit/s PoE PD port” on page 30](#).

1.6 Ethernet ports

You can connect terminal devices and other segments on the ports of the device via twisted pair cables or F/O cables.

1.6.1 Gigabit combo port

You have the option to alternatively connect F/O (via SFP transceivers) or twisted pairs to a combo port.

- Only plug a connector or SFP transceiver that you want to use for the data transmission into the socket of the combo port.

■ 10/100/1000 Mbit/s PoE PD port

Device variants featuring working voltage with the characteristic value P or W have this port exclusively.

The 10/100/1000 Mbit/s PoE PD port offers you the ability to connect network components according to the IEEE 802.3 10BASE-T/100BASE-TX/1000BASE-T and IEEE 802.3af/at standard.

This port supports:

- ▶ Autocrossing (if autonegotiation is activated)
- ▶ Autonegotiation
- ▶ Autopolarity
- ▶ 10 Mbit/s half-duplex mode, 10 Mbit/s full duplex mode
- ▶ 100 Mbit/s half-duplex mode, 100 Mbit/s full duplex mode
- ▶ 1000 Mbit/s full duplex

Delivery state: autonegotiation active.

The socket housing is electrically connected with the front panel.

The pin assignment corresponds to MDI-X.

When using 10/100 Mbit/s, the PoE power is supplied via the signal-transmitting wire pair (phantom voltage) or via the free wire pairs (spare pair supply).

	Pin	Function	PoE PD voltage
	1	RD+ Receive path	—
	2	RD- Receive path	—
	3	TD+ Transmission path	—
	4	— —	x pin
	5	— —	x pin
	6	TD- Transmission path	—
	7	— —	y pin
	8	— —	y pin

Table 4: Pin assignment of the 10/100 Mbit/s PoE PD port, RJ45 socket, MDI-X mode, spare pair voltage

	Pin	Function	PoE PD voltage
	1	RD+ Receive path	x pin
	2	RD- Receive path	x pin
	3	TD+ Transmission path	y pin
	6	TD- Transmission path	y pin
	4,5,7,8	—	—

Table 5: Pin assignment of the 10/100 Mbit/s PoE PD port, RJ45 socket, MDI-X mode, phantom voltage

	Pin	Function	PoE PD voltage
	1	BI_DB+	x pin
	2	BI_DB-	x pin
	3	BI_DA+	y pin
	4	BI_DD+	y pin
	5	BI_DD-	y pin
	6	BI_DA-	y pin
	7	BI_DC+	x pin
	8	BI_DC-	x pin

Table 6: Pin assignment of the 10/100/1000 Mbit/s PoE PD port, RJ45 socket, 1000 Mbit/s mode, MDI-X mode

■ 10/100/1000 Mbit/s twisted pair port

Device variants featuring working voltage with the characteristic value C or K have this port exclusively.

The 10/100/1000 Mbit/s twisted pair port offers you the ability to connect network components according to the IEEE 802.3 10BASE-T/100BASE-TX/1000BASE-T standard.

This port supports:

- ▶ Autocrossing (if autonegotiation is activated)
- ▶ Autonegotiation
- ▶ Autopolarity

- ▶ 10 Mbit/s half-duplex mode, 10 Mbit/s full duplex mode
- ▶ 100 Mbit/s half-duplex mode, 100 Mbit/s full duplex mode
- ▶ 1000 Mbit/s full duplex

Delivery state: autonegotiation active.

The socket housing is electrically connected with the front panel.

The pin assignment corresponds to MDI-X.

	Pin	Function
	1	BI_DB+
	2	BI_DB-
	3	BI_DA+
	4	BI_DD+
	5	BI_DD-
	6	BI_DA-
	7	BI_DC+
	8	BI_DC-

Table 7: Pin assignment of the 10/100/1000 Mbit/s twisted pair port, RJ45 socket, 1000 Mbit/s mode, MDI-X mode

■ 1000 Mbit/s F/O port

The 1000 Mbit/s F/O port offers you the ability to connect network components according to the IEEE 802.3 1000BASE-SX/1000BASE-LX standard.

This port supports:

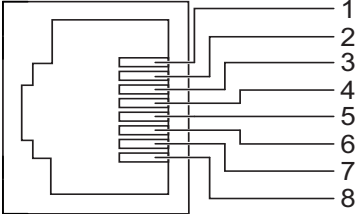
- ▶ Full duplex mode

1.6.2 10/100/1000 Mbit/s twisted-pair connection (optional)

See the properties of this port “[10/100/1000 Mbit/s twisted pair port](#)” on [page 31](#).

1.7 Connections for antennas

You require antennas for operating the devices.

The devices have 3 reverse SMA connections (SMA = Sub-Miniature Version A) on each WLAN module.

For optimum reception and transmission power, you need antennas suitable for the particular application. The BAT Planner of Hirschmann assists you in the selection of suitable antennas. You can obtain the BAT Planner for free at www.hirschmann.com.

The “Antenna Guide” document provides an overview of the antennas that can be used as well as the suitable antenna accessories.

This document is available as a PDF file on the enclosed CD/DVD or as a download from the Hirschmann product pages (www.hirschmann.com).

1.8 Display elements

After the working voltage is set up, the software starts and initializes itself. Afterwards, the device performs a self-test. During this process, various LEDs light up.

These actions take less than 1 minute.

1.8.1 Meaning of the LEDs

The following terms describe the behavior of the LEDs:

- ▶ **Regular flashing** means that the LED is running through the described statuses in the specified sequence at intervals (e.g. red/green or red/off).
- ▶ **Brief flashing** means that the LED lights up very briefly in the color specified, then is switched off for a much longer time (about 10x as long).
- ▶ **Inverse flashing** means that the LED is switched off for a brief time and then lights up for considerably longer (about 10x as long) in the specified color.
- ▶ **Flickering** means that the LED switches on and off at irregular intervals.
- ▶ **Running light** means the coordinated glowing of several LEDs. This gives the optical impression that a light source is moving from left to right and back.

1.8.2 Device state

These LEDs provide information about conditions which affect the operation of the whole device.

LED display elements for device status

P1○ ○P2

WLAN1○ ○WLAN2

P1	Power supply connection 1
P2	Power supply connection 2
WLAN1	WLAN module 1
WLAN2	For device variants with 2 WLAN modules: WLAN module 2

Note: For device variants with 1 WLAN module, this LED is unlabeled and solely lights up after the configuration is reset (hard reset).

See [“Operation element \(reset button\)” on page 37](#).

P1, P2 (green/red LED)		Power
off		Connection is voltage-free ^a
green	on continuously	Voltage present, device is operational.
red/green	flashing (slowly)	Charge lock active. ^b
red/green	flashing (quickly)	Unprotected configuration as no password or the default password is set. ^a
red/off	flashing (quickly)	Hardware error detected. ^b

P1, P2 (green/red LED)		Power
red/green	Running light of P1 and P2	A BAT controller WLC with an incompatible protocol is connected.
green	Running light of P1 and P2	Device is searching for a BAT controller WLC.

- If both connections are voltage-free, the power supply is possibly running via an active Ethernet connection on the PoE port. The port status LEDs directly on the port show you whether an Ethernet connection is active.
- Which LED displays the corresponding response depends on the configuration of the power supply connections. P2 always performs signaling if a voltage is solely present on the connection for working voltage 2. In all other cases, signaling is performed by P1.

WLAN 1, WLAN 2 (green/red LEDs)		WLAN connection and WLAN data traffic of internal WLAN modules
Off		No WLAN network defined or WLAN module deactivated. The WLAN module does not send any beacons.
Green		At least one WLAN network defined and WLAN module activated. The WLAN module sends beacons.
Green	flashing inversely	Number of flashes = number of connected WLAN stations and P2P radio lines, then there is a break.
Green	flashing	DFS scanning or another scan procedure.
Red	flashing	Hardware error detected in the WLAN module.

1.8.3 Port state

These LEDs display port-related information.
The LEDs are directly located on the ports.

LS/DA (green/yellow LED)		Data, link status Status of the LAN interfaces
Off		No network device connected
Green	on continuously	Ethernet connection active
Yellow	flickering	Data traffic

1.9 Management interfaces

1.9.1 V.24 interface (external management)

This interface is designed as an 8-pin, A-coded M12 plug.

The V.24 user interface is serial and allows you to connect the following devices directly:

- ▶ External management station (VT100 terminal or PC with appropriate terminal emulation). With this management station, the Command Line Interface (CLI) is available to you. Furthermore, the system monitor is available to you at the system start.

You will find more information here:

- [See table 9 on page 36.](#)

- ▶ BAT-R device. Connecting the BAT-R device allows you to automate the configuration of a point-to-point WLAN line by connecting two devices directly via the serial interface.

You will find more information here:

- User Manual Configuration and Administration Guide
- [See table 10 on page 36.](#)

VT 100 terminal settings

Speed	115200 bit/s
Data	8 bit
Stopbit	1 bit
Handshake	Hardware
Parity	none

The socket housing is electrically connected to the front panel of the device. The V.24 interface is electrically insulated from the working voltage.

- Only use a shielded cable.

Pins of the M12 socket on the device	Pin	Function	Description of functions
	1	GND	Ground
	2	DTR	Data terminal ready
	3	TxD	Transmit data
	4	RxD	Receive data
	5	DCD	Data carrier detect
	6	DSR	Datset ready
	7	RTS	Request to send
	8	CTS	Clear to send

Table 8: Pin assignment of the V.24 interface, 8-pin, A-coded M12 socket

Pins of the M12 socket on the device	Pin assignment for the connection with a cable	Pins of the DB9 plug on the external device
	<pre> 1 ————— 5 2 ————— 4 3 ————— 3 4 ————— 2 5 ————— 1 6 ————— 6 7 ————— 7 8 ————— 8 </pre>	

Table 9: Pin assignment for the connection with a cable:
8-pin, A-coded M12 plug to DB9 connector

You can order a terminal cable M12, 8-pin, to DB9 as an accessory.
See “Accessories” on page 69.

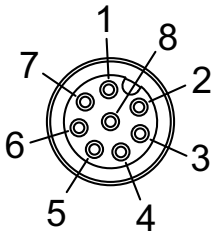
Pins of the M12 socket on the device	Pin assignment for the connection with a cable	Pins of the M12 socket on the device
	<pre> 1 ————— 1 2]————— [2 3]————— [3 4]————— [4 5]————— [5 6]————— [6 7]————— [7 8]————— [8 </pre>	

Table 10: Pin assignment for the connection with a cable:
8-pin, A-coded M12 plug to 8-pin, A-coded M12 plug (point-to-point WLAN line)

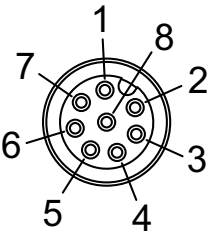
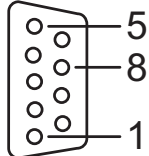
Note: With the point-to-point WLAN line, the following pins are short-circuited at both ends:

- ▶ 2 (DTR) + 6 (DSR)
- ▶ 7 (RTS) + 8 (DSR)

1.9.2 USB interface

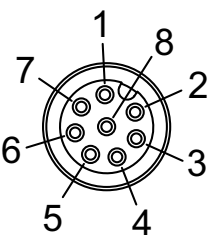
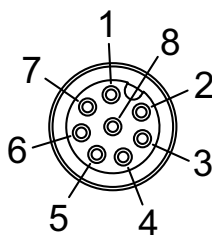
This interface offers you the ability to connect the storage medium AutoConfiguration AdapterACA21-USB. This storage medium is used for saving/loading the configuration and diagnostic functions, and for loading the software.

The USB interface has the following properties:

- ▶ Supports the USB master mode
- ▶ Supports USB 1.1 (data rate max. 12 MBit/s)
- ▶ Connectors: type A
- ▶ Supplies current of max. 500 mA
- ▶ Voltage not potential-separated

Figure	Pin	Operation
	1	VCC (VBus)
	2	- Data
	3	+ Data
	4	Ground (GND)

Table 11: Pin assignment of the USB interface

1.10 Signal contact

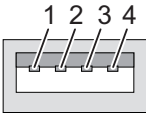

Figure 2: Signal contact: 2-pin terminal block with screw locking

Device variants featuring working voltage with the characteristic value C, K or W have a signal contact exclusively.

You have the option of setting the signal contact manually using the device management.

1.11 Operation element (reset button)

The device has a reset button.

You will find further information under [“Operation” on page 51](#).

2 Installation

- Before installing and starting up the device, read the safety instructions. See [“Safety instructions” on page 5](#).

2.1 Overview

The devices have been developed for practical application in a harsh industrial environment.

On delivery, the device is ready for operation.

The following steps should be performed to install and configure a device:

- ▶ [Unpacking and checking the content of the package](#)
- ▶ [Installing and grounding the device](#)
- ▶ [Installing an SFP transceiver \(optional\)](#)
- ▶ [Installing the antennas](#)
- ▶ [Connecting the terminal blocks \(optional\)](#)
- ▶ [Operating the device](#)
- ▶ [Connecting data cables](#)

2.2 Unpacking and checking the content of the package

- Check whether the package includes all items named in section [“Scope of delivery” on page 68](#).
- Check the individual parts for transport damage.

2.3 Installing and grounding the device

WARNING

FIRE HAZARD

Install the device in a fire protected enclosure according to EN 60950-1. In the following exceptional cases, you do **not** require a fire-protected shell:

- ▶ You are supplying voltage to the device only via PoE.
- ▶ You are supplying only 24 V to the device and are using a fuse.
Regarding the properties of this fuse: [See “General technical data” on page 56.](#)

Failure to follow these instructions can result in death, serious injury, or equipment damage.

WARNING

ELECTRIC SHOCK

Applies to device variants with the characteristic value B and D for mounting (indoor service access area, and outdoors):
Install this device solely in a switch cabinet or in an operating site with restricted access, to which maintenance staff have exclusive access.

Failure to follow these instructions can result in death, serious injury, or equipment damage.

2.3.1 Installing the device onto the DIN rail

To mount the device onto a horizontally mounted 35 mm DIN rail according to DIN EN 60715, proceed as follows:

- Slide the upper snap-in guide of the device into the DIN rail.
- Pull down the locking gate using a screwdriver, and press the lower part of the device against the DIN rail.
- Snap in the device by releasing the locking gate.

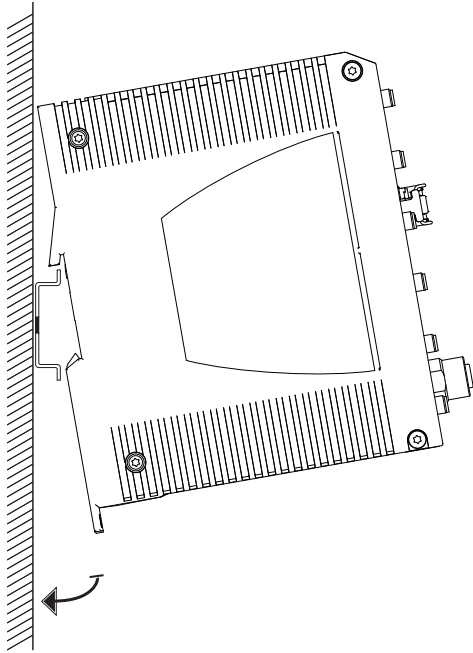

Figure 3: Mounting on the DIN rail

2.3.2 Mounting on a vertical flat surface

You have the option of attaching the device to a vertical flat surface. The necessary wall mounting plate you obtain as an accessory.

[See “Accessories” on page 69.](#)

Enclosed with every wall mounting plate is a mounting instruction that takes you through the mounting procedure.

- Follow the mounting instruction enclosed with the accessory.

2.3.3 Grounding the device

WARNING

ELECTRIC SHOCK

Ground the device before connecting any other cables.

Failure to follow these instructions can result in death, serious injury, or equipment damage.

The device is grounded via the separate ground screw.

The device variants featuring working voltage with the characteristic value K and K have a protective ground.

The device variants featuring working voltage with the characteristic value W have a functional ground.

- Ground the device via the ground screw.

2.4 Installing an SFP transceiver (optional)

- Before attaching an SFP transceiver, first remove the protective cap from the SFP transceiver.
- Push the SFP transceiver with the lock closed into the socket until you hear it latch in.



- For this device, only use suitable SFP modules from Hirschmann.
[See “Accessories” on page 69.](#)

2.5 Installing the antennas

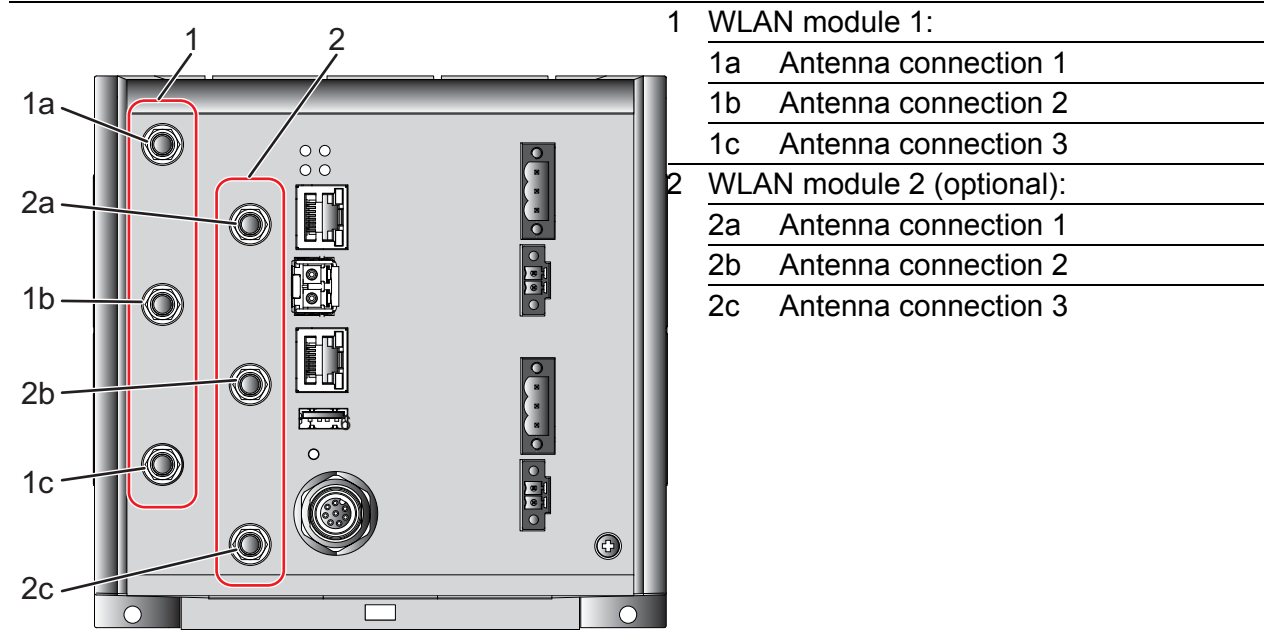

Table 12: Antenna connections

Note: When installing antennas, observe the regulations of the country in which you are operating the WLAN device with regard to the general operating permission and the maximum emission levels.

If you connect to 2 BAT-R devices antennas to 2 WLAN modules, ensure that there is a distance of at least 2 m between the BAT-R devices.

If you would like to connect several antennas to a WLAN module, align the antennas so that the points of the antennas point away from each other in a star shape.

- Install at least one antenna on the WLAN module that you would like to use.
- Insert the terminators supplied into the unused sockets to avoid radio signals from one WLAN module being received by the other WLAN module.

Relevant for use of BAT-ANT-N-MiMo-18N-IP65 with FCC and approval 2, characteristic value H. The devices are labeled as follows:

► “FCC ID: U99EWLAN2 and IC: 4019A-EWLAN2”

Connect the BAT-ANT-N-MiMo-18N-IP65 to the WLAN module as follows:

- Connect the antenna port "Ver" with the WLAN antenna port 1.
- Connect the antenna port "+45 °" with the WLAN antenna port 2.
- Connect the antenna port "-45 °" with the WLAN antenna port 3.
- Connect the BAT-ANT-N-MiMo-18N-IP65 in this way exclusively.

2.6 Connecting the terminal blocks (optional)

WARNING

ELECTRIC SHOCK

Never insert pointed objects (narrow screwdrivers, wires, etc.) into the device or into the connection terminals for electric conductors. Do not touch the connection terminals.

Start connecting the electrical wires solely if **all** the above requirements are fulfilled.

See [“Working voltage” on page 6.](#)

Failure to follow these instructions can result in death, serious injury, or equipment damage.

Note: The working voltage is electrically isolated from the housing.

Note: For devices with 2 power supply connections:

You have the option of supplying the working voltage redundantly, without load distribution.

Both working voltage inputs are uncoupled.

2.6.1 Working voltage with the characteristic value C

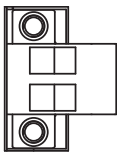

Figure 4: Working voltage with the characteristic value C: 2-pin terminal block with screw locking

Type of the voltages that can be connected	Specification of the working voltage	Pin assignment on the device
DC voltage	Rated voltage range DC 24 V ... 48 V	+ Plus terminal of the working voltage
	Voltage range DC incl. maximum tolerances 18 V ... 60 V	- Minus terminal of the working voltage

Table 13: Working voltage with the characteristic value °C: Type and specification of the working voltage, pin assignment on the device

For the working voltage to be connected—for device variants with 2 working voltage connections of this type, for **every** working voltage to be connected—perform the following steps:

- Remove the power connector from the device.
- Connect the wires according to the pin assignment on the device with the clamps.
- Fasten the wires connected by tightening the terminal screws.

2.6.2 Working voltage with the characteristic value K

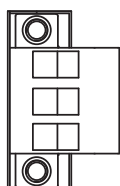

Figure 5: Working voltage with the characteristic value K: 3-pin terminal block with screw locking



Type of the voltages that can be connected	Specification of the working voltage	Pin assignment on the device
DC voltage	Rated voltage range DC 60 V ... 250 V Voltage range DC incl. maximum tolerances 48 V ... 320 V	+/L Plus terminal of the working voltage
		-/N Minus terminal of the working voltage
		 Protective conductor
AC voltage	Rated voltage range AC 110 V ... 230 V, 50 Hz ... 60 Hz Voltage range AC incl. maximum tolerances 88 V ... 265 V, 47 Hz ... 63 Hz	+/L Outer conductor
		-/N Neutral conductor
		 Protective conductor

Table 14: Working voltage with the characteristic value K: Type and specification of the working voltage, pin assignment on the device

For **every** working voltage to be connected, perform the following steps:

WARNING

ELECTRIC SHOCK

Install this device solely in a switch cabinet or in an operating site with restricted access, to which maintenance staff have exclusive access.

Failure to follow these instructions can result in death, serious injury, or equipment damage.

- Remove the power connector from the device.
- Connect the protective conductor according to the pin assignment on the device with the clamp.
- Fasten the wires connected by tightening the terminal screws.
- Connect the wires according to the pin assignment on the device with the clamps.
- Fasten the wires connected by tightening the terminal screws.

2.6.3 Working voltage with the characteristic value W

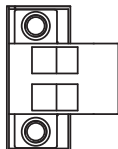

Figure 6: Operating voltage type W: 2-pin terminal block with screw locking

Type of the voltages that can be connected	Specification of the working voltage	Pin assignment on the device
DC voltage	Nominal voltage DC 24 V	+ Plus terminal of the working voltage
	Voltage range DC incl. maximum tolerances 18 V ... 32 V	- Minus terminal of the working voltage

Table 15: Working voltage with the characteristic value W: Type and specification of the working voltage, pin assignment on the device

For **every** working voltage to be connected, perform the following steps:

- Remove the power connector from the device.
- Connect the wires according to the pin assignment on the device with the clamps.
- Fasten the wires connected by tightening the terminal screws.

2.6.4 Signal contact

Device variants featuring working voltage with the characteristic value C, K or W have a signal contact exclusively.

For every signal contact to be connected, make sure the following requirements are met:

- ▶ The electrical wires are voltage-free.
- ▶ The connected voltage is limited by a current limitation device or a fuse.
- Observe the electrical threshold values for the signal contact.
[See “General technical data” on page 56.](#)
- Connect the wires according to the pin assignment on the device with the clamps.
- Mount the terminal block on the device using screws.

2.7 Operating the device

WARNING

ELECTRIC SHOCK

Ground the device before connecting any other cables.
Connect solely an working voltage that corresponds to the type plate of your device.

Failure to follow these instructions can result in death, serious injury, or equipment damage.

By connecting the working voltage via a terminal block or a twisted-pair cable (Power over Ethernet), you start the operation of the device.

2.7.1 Connecting the power supply through a terminal block

Note: Relevant for North America:

The torque for tightening the working voltage terminal block on the device is 4.5 lb-in (0.51 Nm).

The torque for tightening the terminal block for the signal contact on the device is 3 lb-in (0.34 Nm).

- Use screws to secure the connectors to the device.
- Enable the working voltage.

2.7.2 Connecting the power supply through PoE

Note: In a PoE installation, solely use devices that comply with the 802.3af/at standard.

Solely for device variants featuring working voltage with the characteristic value P or W:

By connecting the working voltage via PoE, you start the operation of the device.

2.8 Connecting data cables

2.8.1 Gigabit combo port

■ 10/100/1000 Mbit/s PoE PD port

You will find further information under [“10/100/1000 Mbit/s PoE PD port” on page 30](#).

Install the data lines according to your requirements.

■ 1000 Mbit/s F/O port

You will find further information under [“1000 Mbit/s F/O port” on page 32](#).

Note: Make sure that you connect LH ports exclusively with LH ports, SX ports exclusively with SX ports, and LX ports exclusively with LX ports.

Install the data lines according to your requirements.

2.8.2 10/100/1000 Mbit/s twisted-pair connection (optional)

You will find further information under [“10/100/1000 Mbit/s twisted-pair connection \(optional\)” on page 32](#).

Install the data lines according to your requirements.

3 Configuration

Note: Two or more devices configured with the same IP address can cause unpredictable operation of your network.

Install and maintain a process that assigns a unique IP address to every device in the network.

3.1 Basic set-up

You find information on the basic settings of the device and on the state on delivery in the following documentation on the supplied CD/DVD:

- ▶ User Manual Configuration and Administration Guide
- ▶ User Manual Operation and Maintenance Guide

3.2 Configuring antennas

Note: When installing antennas, observe the regulations of the country in which you are operating the WLAN device with regard to the general operating permission and the maximum emission levels.

■ Transmission power

The operator of a WLAN radio installation must adhere to the applicable transmission threshold values.

- Use the LANconfig or the Webconfig to start the configuration of the device. (This software is located on the CD/DVD provided.)
- Go to the settings for Wireless LAN.
- Enter the country in which you are installing the device (see the following figure):

General Security Stations 802.11i/WEP IEEE 802.1X WLC Trace

General

This is where you can program common settings for all wireless LAN interfaces.

Country

ARP handling

Indoor only mode activated

Email address for WLAN events (max. 254 characters)

Interfaces

This is where you can program further settings for each physical wireless LAN interface.

[Physical WLAN settings - Operation](#)

[Physical WLAN settings - Radio](#)

[Physical WLAN settings - Performance](#)

[Physical WLAN settings - Point-to-Point](#)

[Physical WLAN settings - Client mode](#)

[Point-to-Point partners - Point-to-Point](#)

[Point-to-Point partners - Alarms](#)

This is where you can program further settings for each logical wireless LAN network (MultiSSID).

This is where you can program further settings for the logical wireless LAN network.

[Logical WLAN settings - Network](#)

[Logical WLAN settings - Transmission](#)

[Logical WLAN settings - Alarms](#)

- Open the configuration for the physical interface to which you are connecting the antenna. On the Radio tab you will find an entry field for the antenna gain (see the following figure):

Physical WLAN settings - Radio

Interface	<input type="text" value="WLAN interface 1"/>
Frequency band	5 GHz (802.11a/n) <input type="button" value="v"/>
Sub-bands	1+2+3 <input type="button" value="v"/>
Channel number	<input type="text" value="Automatic selection"/>
Channel number	Automatic selection <input type="button" value="v"/>
2.4 GHz mode	802.11g/b/n (mixed) <input type="button" value="v"/>
5 GHz mode	802.11a/n (mixed) <input type="button" value="v"/>
Double bandwidth (20/40MHz)	Allow 40 MHz <input type="button" value="v"/>
Antenna grouping	Auto <input type="button" value="v"/>
Antenna gain	<input type="text" value="0"/> dBi (possible values: 0 - 255)
TX power reduction	<input type="text" value="0"/> dB (possible values: 0 - 255)
Access point density	Low <input type="button" value="v"/>
Maximum distance	<input type="text" value="0"/> km (possible values: 0 - 65535)
Channel list	<input type="text" value=""/> (max. 48 characters)
Background scan	<input type="text" value="0"/> (possible values: 0 - 2147483647)
Background scan unit	seconds <input type="button" value="v"/>

- Subtract the cable attenuation and any losses due to over voltage protector installed devices from the antenna gain, and enter the result in dB in the antenna gain field.

4 Operation

The device has a reset button.

Depending on how long you press the reset button, you have different functions available.

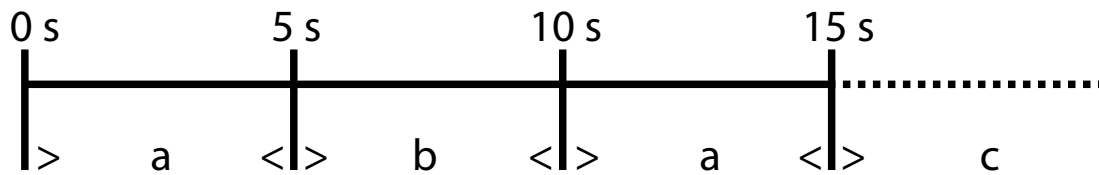

Figure 7: Functions of the reset button

a – soft reset

b – hard reset

c – load configuration; if the device does not provide a configuration: soft reset

4.1 Restarting the device (soft reset/reboot)

The soft reset/reboot is used to reset the device to the current configuration.

- Press the reset button for maximum 4 seconds or 11 to 15 seconds.

4.2 Resetting the configuration (hard reset)

The hard reset is used to reset the device to the factory settings. You require this function, for example, if the connection to the device configuration is interrupted or if you want to reconfigure the device.

Note: When performing a hard reset, the user settings get lost, and the device starts with the factory settings based on the firmware that you have been using. Therefore, if applicable, save the current configuration of the device before the reset.

- Press the reset button for 6 to 9 seconds. During this process, the LEDs light up for a long period.

4.3 Loading the configuration

- To load a configuration saved on the device, press the reset button for at least 16 seconds.

If the device does not provide a saved configuration, the device restarts (= soft restart/reboot).

5 Maintenance and service

- ▶ When designing this device, Hirschmann largely avoided using wear parts. The parts subject to wear and tear are dimensioned to last longer than the lifetime of the product when it is operated normally. Operate this device according to the specifications (see on page 56 “Technical data”).
- ▶ Relays are subject to natural wear. This wear depends on the frequency of the switching operations. Check the resistance of the closed relay contacts and the switching function depending on the frequency of the switching operations.
- ▶ Hirschmann continually works on improving and developing the software. Regularly check whether there is a new version of the software that provides you with additional benefits. You find software information and downloads on the Hirschmann product pages (www.hirschmann.com).
- ▶ Depending on the degree of pollution in the operating environment, check at regular intervals that the ventilation slots in the device are not obstructed.

Note: You will find information about the complaints and returns procedures in the Internet under

<http://www.beldensolutions.com/en/Service/Repairs/index.phtml> .

6 Disassembly

6.1 Removing the device

WARNING

ELECTRIC SHOCK

Disconnect the grounding solely after disconnecting all other cables.

Failure to follow these instructions can result in death, serious injury, or equipment damage.

- Disconnect the data cables.
- Disable the working voltage.
- Disconnect the terminal blocks.
- Remove the antennas.
- Disconnect the grounding.

To remove the device from the DIN rail, you proceed as follows:

- Insert a screwdriver horizontally below the housing into the locking gate.
- Pull the locking gate down without tilting the screwdriver.
- Fold the device up.

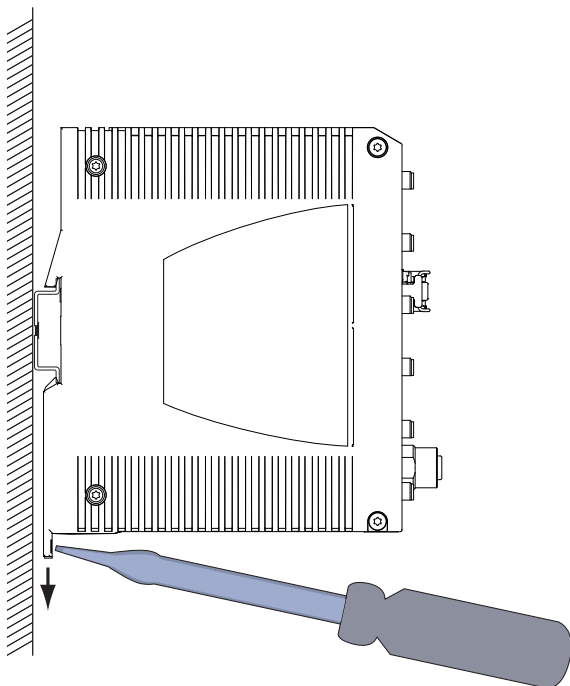

6.2 Removing an SFP transceiver (optional)

- Pull the SFP transceiver out of the socket by means of the opened lock.
- Close the socket with the protective cap.



7 Technical data

■ General technical data

Weight	Device variants featuring working voltage with the characteristic value W	approx. 1200 g		
	Device variants featuring working voltage with the characteristic value C or K	approx. 1500 g		
Working voltage with the characteristic value C	Class 2			
	Rated voltage range DC	24 V ... 48 V		
	Voltage range DC incl. maximum tolerances	18 V ... 60 V		
	Connection type	2-pin terminal block		
	Power failure bypass	> 10 ms at 20.4 V DC		
	Overload current protection at input	Non-replaceable fuse		
	Back-up fuse for each voltage input when supply is via 2 inputs	Nominal rating:	Max. 1.5 A	
		Characteristic:	slow blow	
	Back-up fuse when 1 voltage input used ^a	Nominal rating:	Max. 3.15 A	
		Characteristic:	slow blow	
Working voltage with the characteristic value K	Back-up fuse when installed in a fire-protection shell according to EN 60950-1	Nominal rating:	Max. 6.3 A	
		Characteristic:	slow blow	
	Rated voltage range AC	110 V ... 230 V, 50 Hz ... 60 Hz		
	Voltage range AC incl. maximum tolerances	88 V ... 265 V, 47 Hz ... 63 Hz		
	Rated voltage range DC	60 V ... 250 V		
	Voltage range DC incl. maximum tolerances	48 V ... 320 V		
	Connection type	3-pin terminal block		
	Power failure bypass	> 10 ms at 98 V AC		
	Overload current protection at input	Non-replaceable fuse		
	Back-up fuse for each voltage input	Nominal rating:	2.5 A	
	Characteristic:	slow blow		
Working voltage with the characteristic value P	Power supply solely through PoE			

Working voltage with the characteristic value W	Class 2	
	Nominal voltage DC	24 V
	Voltage range DC incl. maximum tolerances	18 V ... 32 V
	Connection type	2-pin terminal block
	Power failure bypass	> 10 ms at 20.4 V DC
	Overload current protection at input	Non-replaceable fuse
	Back-up fuse for each voltage input when supply is via 2 inputs	Nominal rating: Max. 1.5 A Characteristic: slow blow
	Back-up fuse when using 1 voltage input ^b	Nominal rating: Max. 3.15 A Characteristic: slow blow
Climatic conditions during operation	Back-up fuse when installed in a fire-protection shell according to EN 60950-1	Nominal rating: Max. 6.3 A Characteristic: slow blow
	Ambient air temperature ^c .	Devices with operating temperature characteristic value S (standard): 0 °C ... +60 °C (+32 °F ... +140 °F) Devices with operating temperature characteristic value E and T (extended): -40 °F ... +158 °F (-40 °C ... +70 °C) ^d Devices with operating temperature characteristic value K (Extended and approvals 1, characteristic value K): -40 °C ... +55 °C
	Humidity	10 % ... 95 % (non-condensing)
	Air pressure	Up to 2000 m (795 hPa), higher altitudes on request maximum 1060 hPa (-1312 ft; -400 m)
	Ambient air temperature ^e .	-40 °F ... +185 °F (-40 °C ... +85 °C)
Climatic conditions during storage	Humidity	10 % ... 95 % (non-condensing)
	Air pressure	minimum 700 hPa (+9842 ft; +3000 m) maximum 1060 hPa (-1312 ft; -400 m)
	Switching current	max. 1 A, SELV
"FAULT" signal contact	Switching voltage	Power supply unit characteristic value C and K: max. 60 V DC or max. 30 V AC, SELV Working voltage with the characteristic value W: max. 30 V DC, SELV
	Pollution degree	2
Protection classes	Laser protection	Class 1 in compliance with IEC 60825-1
	Degree of protection	IP20

- When supplied with 24 V, possible as alternative to back-up fuse:
Voltage supply based on NEC Class 2 or EN 60950-1 Limited Power Source
- As an alternative to the back-up fuse is possible:
Voltage supply according to Class 2 or EN 60950-1 Limited Power Source
- Temperature of the ambient air at a distance of 2 inches (5 cm) from the device
- Only use SFP transceivers with the "EEC" extension.
- Temperature of the ambient air at a distance of 2 inches (5 cm) from the device

■ Dimension drawings

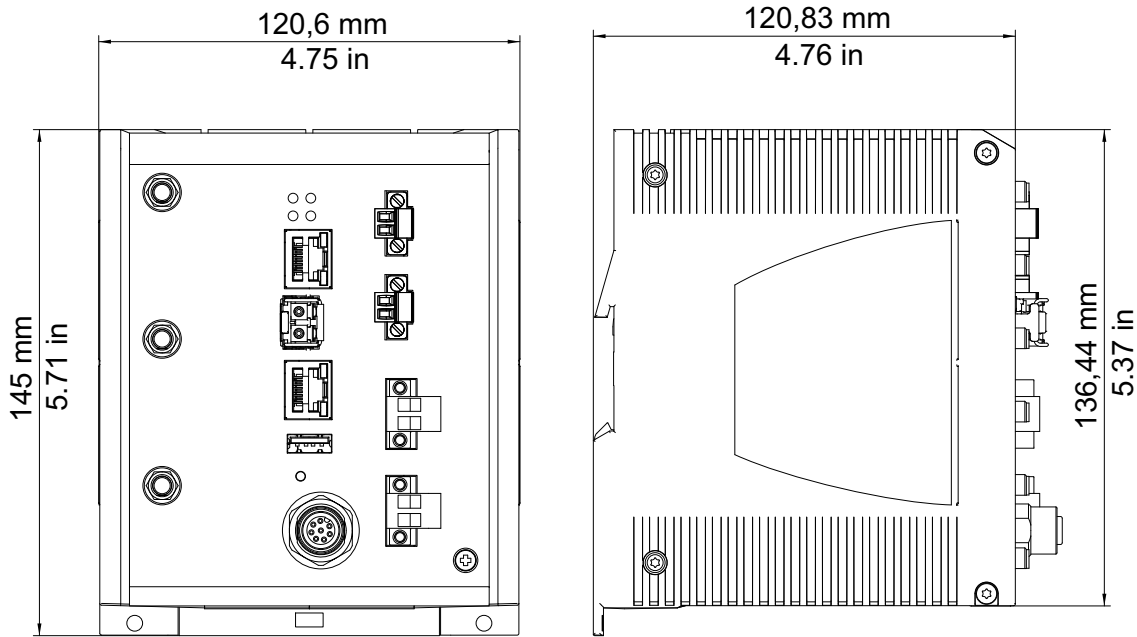

Figure 8: Dimensions of device variants featuring working voltage with the characteristic value W or type P. See table 1 on page 21.

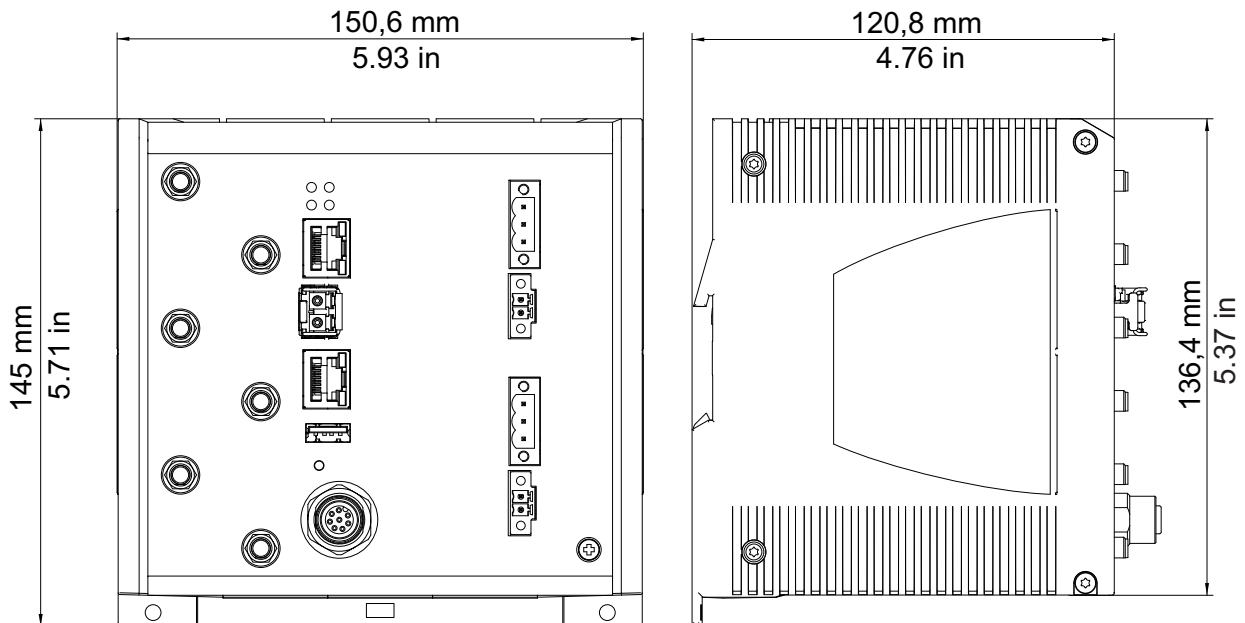

Figure 9: Dimensions of device variants featuring working voltage with the characteristic value C or type K. See table 1 on page 21.

■ Radio technology

Antenna connection	For each WLAN module: 3 × reverse SMA connection
Range	Up to 12.4 miles (20 km, depending on antenna used, frequency range and data rate)
Encryption	<ul style="list-style-type: none">▶ IEEE 802.11i/WPA2 with passphrase or IEEE 802.1x and hardware-accelerated AES▶ User authentication with IEEE 802.1x/EAP or LEPS▶ IEEE-802.1x supplicant in the Client Mode▶ WPA/TKIP▶ WEP▶ Access Control Lists▶ WLAN port and protocol filter▶ RADIUS client and server▶ Integrated firewall with QoS▶ Port filter▶ Protocol filter▶ IDS and DoS protection▶ PMK caching and preauthentication for faster roaming with IEEE 802.1x
Frequency range	Support of 2.4 GHz and 5 GHz: 2400 MHz to 2483.5 MHz (ISM) and 5170 MHz to 5850 MHz
Modulation technology	22M0F7D (DSSS/OFDM) with 2.4 GHz 20M0G7D (OFDM) with 5 GHz
Radio topology	Access point device variants: WLAN access point, bridge, router, point-to-point, client, client-bridge mode, fixed mesh with RSTP Client device variants: WLAN client, client-bridge mode
Roaming	Seamless handover, IAPP support, IEEE 802.11d support, background scanning for rogue AP detection and fast roaming

■ Receive sensitivity, transmission power and data rate according to IEEE 802.11a/b/g/n

The values shown in the following tables show maximum values of the WLAN module version for high-gain antennas. The values are in no case to be perceived as a guaranteed property of the overall product. In some country profiles, the module automatically reduces the data rate and transmit power downward. This is due to national standards.

Data rate	Typical transmission power	Typical receive sensitivity
06 Mbps	16 dBm	-93 dBm
09 Mbps	16 dBm	-93 dBm
12 Mbps	16 dBm	-93 dBm
18 Mbps	16 dBm	-91 dBm
24 Mbps	16 dBm	-88 dBm
36 Mbps	15 dBm	-84 dBm
48 Mbps	13 dBm	-80 dBm
54 Mbps	12 dBm	-79 dBm

Table 16: Receive sensitivity, transmission power and data rate according to IEEE 802.11a

Data rate	Typical transmission power	Typical receive sensitivity
1 Mbps	19 dBm	-94 dBm
11 Mbps	19 dBm	-94 dBm

Table 17: Receive sensitivity, transmission power and data rate according to IEEE 802.11b

Data rate	Typical transmission power	Typical receive sensitivity
06 Mbps	18 dBm	-94 dBm
09 Mbps	18 dBm	-94 dBm
12 Mbps	18 dBm	-90 dBm
18 Mbps	18 dBm	-89 dBm
24 Mbps	18 dBm	-85 dBm
36 Mbps	17 dBm	-82 dBm
48 Mbps	16 dBm	-78 dBm
54 Mbps	15 dBm	-77 dBm

Table 18: Receive sensitivity, transmission power and data rate according to IEEE 802.11g

Data rate	Typical transmission power	Typical receive sensitivity
MCS0	18 dBm	-87 dBm
MCS1	18 dBm	-90 dBm
MCS2	18 dBm	-86 dBm
MCS3	18 dBm	-82 dBm
MCS4	18 dBm	-79 dBm
MCS5	16 dBm	-75 dBm
MCS6	16 dBm	-73 dBm
MCS7	15 dBm	-72 dBm
MCS8	22 dBm	-87 dBm
MCS9	21 dBm	-90 dBm
MCS10	22 dBm	-86 dBm
MCS11	21 dBm	-82 dBm
MCS12	16 dBm	-79 dBm
MCS13	16 dBm	-75 dBm
MCS14	15 dBm	-73 dBm
MCS15	15 dBm	-72 dBm
MCS16	23 dBm	-87 dBm
MCS17	23 dBm	-90 dBm
MCS18	23 dBm	-86 dBm
MCS19	23 dBm	-82 dBm
MCS20	16 dBm	-79 dBm
MCS21	17 dBm	-75 dBm
MCS22	17 dBm	-73 dBm
MCS23	16 dBm	-72 dBm

Table 19: Receive sensitivity, transmission power and data rate according to IEEE 802.11n and for the 2.412 GHz – 2.472 GHz bandwidth

Data rate	Typical transmission power	Typical receive sensitivity
MCS0	17 dBm	-92 dBm
MCS1	17 dBm	-91 dBm
MCS2	17 dBm	-89 dBm
MCS3	17 dBm	-84 dBm

Table 20: Receive sensitivity, transmission power and data rate according to IEEE 802.11n and for the 5.180 GHz – 5.825 GHz bandwidth

Data rate	Typical transmission power	Typical receive sensitivity
MCS4	17 dBm	-81 dBm
MCS5	15 dBm	-77 dBm
MCS6	14 dBm	-75 dBm
MCS7	14 dBm	-73 dBm
MCS8	20 dBm	-92 dBm
MCS9	20 dBm	-91 dBm
MCS10	19 dBm	-89 dBm
MCS11	20 dBm	-84 dBm
MCS12	18 dBm	-81 dBm
MCS13	15 dBm	-77 dBm
MCS14	15 dBm	-75 dBm
MCS15	14 dBm	-73 dBm
MCS16	21 dBm	-92 dBm
MCS17	21 dBm	-91 dBm
MCS18	21 dBm	-89 dBm
MCS19	21 dBm	-84 dBm
MCS20	16 dBm	-81 dBm
MCS21	15 dBm	-77 dBm
MCS22	14 dBm	-75 dBm
MCS23	14 dBm	-73 dBm

Table 20: Receive sensitivity, transmission power and data rate according to IEEE 802.11n and for the 5.180 GHz – 5.825 GHz bandwidth

■ **Receiver sensitivity, transmit power, and data rate of the WLAN module version for high-gain antennas (approvals 2, characteristic value H) according to IEEE 802.11a/b/g/n**

The values shown in the following tables show maximum values of the WLAN module version for high-gain antennas. The values are in no case to be perceived as a guaranteed property of the overall product. In some country profiles, the module automatically reduces the data rate and transmit power downward. This is due to national standards.

Data rate	Typical transmission power	Typical receive sensitivity
06Mbps	10 dBm	-93 dBm
09Mbps	10 dBm	-93 dBm
12Mbps	10 dBm	-93 dBm
18Mbps	10 dBm	-91 dBm
24Mbps	10 dBm	-88 dBm
36Mbps	9 dBm	-84 dBm
48Mbps	7 dBm	-80 dBm
54Mbps	6 dBm	-79 dBm

Table 21: Receive sensitivity, transmission power and data rate according to IEEE 802.11a

Data rate	Typical transmission power	Typical receive sensitivity
1Mbps	19 dBm	-94 dBm
11Mbps	19 dBm	-94 dBm

Table 22: Receive sensitivity, transmission power and data rate according to IEEE 802.11b

Data rate	Typical transmission power	Typical receive sensitivity
06Mbps	18 dBm	-94 dBm
09Mbps	18 dBm	-94 dBm
12Mbps	18 dBm	-90 dBm
18Mbps	18 dBm	-89 dBm
24Mbps	18 dBm	-85 dBm
36Mbps	17 dBm	-82 dBm

Table 23: Receive sensitivity, transmission power and data rate according to IEEE 802.11g

Data rate	Typical transmission power	Typical receive sensitivity
48Mbps	16 dBm	-78 dBm
54Mbps	15 dBm	-77 dBm

Table 23: Receive sensitivity, transmission power and data rate according to IEEE 802.11g

Data rate	Typical transmission power	Typical receive sensitivity
MCS0	18 dBm	-87 dBm
MCS1	18 dBm	-90 dBm
MCS2	18 dBm	-86 dBm
MCS3	18 dBm	-82 dBm
MCS4	18 dBm	-79 dBm
MCS5	16 dBm	-75 dBm
MCS6	16 dBm	-73 dBm
MCS7	15 dBm	-72 dBm
MCS8	22 dBm	-87 dBm
MCS9	21 dBm	-90 dBm
MCS10	22 dBm	-86 dBm
MCS11	21 dBm	-82 dBm
MCS12	16 dBm	-79 dBm
MCS13	16 dBm	-75 dBm
MCS14	15 dBm	-73 dBm
MCS15	15 dBm	-72 dBm
MCS16	23 dBm	-87 dBm
MCS17	23 dBm	-90 dBm
MCS18	23 dBm	-86 dBm
MCS19	23 dBm	-82 dBm
MCS20	16 dBm	-79 dBm
MCS21	17 dBm	-75 dBm
MCS22	17 dBm	-73 dBm
MCS23	16 dBm	-72 dBm

Table 24: Receive sensitivity, transmission power and data rate according to IEEE 802.11n and for the 2.412 GHz – 2.472 GHz bandwidth

Data rate	Typical transmission power	Typical receive sensitivity
MCS0	11 dBm	-92 dBm
MCS1	11 dBm	-91 dBm
MCS2	11 dBm	-89 dBm
MCS3	11 dBm	-84 dBm
MCS4	11 dBm	-81 dBm
MCS5	9 dBm	-77 dBm
MCS6	8 dBm	-75 dBm
MCS7	8 dBm	-73 dBm
MCS8	7 dBm	-92 dBm
MCS9	7 dBm	-91 dBm
MCS10	6 dBm	-89 dBm
MCS11	7 dBm	-84 dBm
MCS12	5 dBm	-81 dBm
MCS13	2 dBm	-77 dBm
MCS14	2 dBm	-75 dBm
MCS15	1 dBm	-73 dBm
MCS16	8 dBm	-92 dBm
MCS17	8 dBm	-91 dBm
MCS18	8 dBm	-89 dBm
MCS19	8 dBm	-84 dBm
MCS20	3 dBm	-81 dBm
MCS21	2 dBm	-77 dBm
MCS22	1 dBm	-75 dBm
MCS23	1 dBm	-73 dBm

Table 25: Receive sensitivity, transmission power and data rate according to IEEE 802.11n and for the 5.180 GHz – 5.825 GHz bandwidth

■ EMC and immunity

EMC interference immunity		
EN 61000-4-2	Electrostatic discharge	
	Contact discharge, test level 4	± 8 kV
	Air discharge, test level 4	± 15 kV
EN 61000-4-3	Electromagnetic field	
	80 MHz ... 1000 MHz	20 V/m
	1400 MHz ... 2700 MHz	10 V/m
EN 61000-4-4	Fast transients (burst), test level 4	
	DC power line	± 4 kV
	AC Power Line	± 4 kV
	Data line	± 4 kV
EN 61000-4-5	Voltage surges	
	DC power line	± 2 kV line/ground; ± 1 kV line/line
	AC Power Line	± 4 kV line/ground; ± 2 kV line/line
	Data line, shielded	± 4 kV line/ground
	Data line, unshielded	± 2 kV line/ground
	Data line, unshielded	± 1 kV line/line
EN 61000-4-6	Conducted interference voltages, test level 3	
	150 kHz ... 80 MHz	10 V
EN 61000-4-9	Pulse magnetic fields	300 A/m
EMC interference emission		
EN 55022	Class B	
FCC 47 CFR Part 15	Class A	
Stability		
Vibration	IEC 60068-2-6 Test FC test level according to IEC 61131-2	
Shock	IEC 60068-2-27 Test Ea test level in accordance with IEC 61131-2, EN 50155	

■ Radio standards

EN 300 328	Electromagnetic compatibility and radio spectrum matters (ERM) - bandwidth transfer systems - data transmission equipment operating in 2.4 GHz ISM band and using spread spectrum modulation technology
EN 301 489-1	Electromagnetic compatibility for radio equipment and services
EN 301 489-17	Electromagnetic compatibility (EMC) for radio equipment and services - specific conditions for 2.4 GHz broadband transmission systems and 5 GHz high-performance RLAN equipment
EN 302 502	Broadband radio access networks (BRAN) – permanently installed broadband data transmission systems with 5.8 GHz band
EN 301 893	Broadband radio access networks (BRAN) – 5 GHz high performance Remote Local Area Network (RLAN)

■ Network range

Note: The line lengths specified for the transceivers apply for the respective fiber data (fiber attenuation and BLP/dispersion).

Product code M-SFP-...	Wave length	Fiber	System attenuation	Example for F/O line length ^a	Fiber attenuation	BLP ^b /dispersion
-SX/LC...	MM 850 nm	50/125 μm	0-7.5 dB	0-550 m	3.0 dB/km	400 MHz×km
-SX/LC...	MM 850 nm	62.5/125 μm	0-7.5 dB	0-275 m	3.2 dB/km	200 MHz×km
-LX/LC...	MM 1310 nm ^c	50/125 μm	0-10.5 dB	0-550 m	1.0 dB/km	800 MHz×km
-LX/LC...	MM 1310 nm ^d	62.5/125 μm	0-10.5 dB	0-550 m	1.0 dB/km	500 MHz×km
-LX/LC...	SM 1310 nm	9/125 μm	0-10.5 dB	0-20 km ^d	0.4 dB/km	3.5 ps/(nm×km)
-LH/LC...	LH 1550 nm	9/125 μm	5-22 dB	23-80 km	0.25 dB/km	19 ps/(nm×km)
-LH+/LC	LH 1550 nm	9/125 μm	15-30 dB	71-108 km	0.25 dB/km	19 ps/(nm×km)
-LH+/LC	LH 1550 nm	9/125 μm	15-30 dB	71-128 km	0.21 dB/km (typically)	19 ps/(nm×km)

Table 26: Fiber port 1000BASE-FX (SFP fiber optic Gigabit Ethernet Transceiver)

- including 3 dB system reserve when compliance with the fiber data is observed
- The bandwidth length product cannot be used to calculate the expansion.
- With F/O adapter compliant with IEEE 802.3-2002 clause 38 (single-mode fiber offset-launch mode conditioning patch cord)
- including 2.5 dB system reserve when compliance with the fiber data is observed

MM = Multimode, SM = Singlemode, LH = Singlemode Longhaul

10/100/1000 Mbit/s twisted pair port

Length of a twisted pair segment max. 100 m (for cat5e cable)

■ Power consumption/power output

Conditions	Maximum power consumption	Power output
When equipped with 1 WLAN module	12.95 W	44.19 BTU (IT)/h
When equipped with 2 WLAN modules	17.5 W	59.71 BTU (IT)/h

■ Scope of delivery

Number	Article
1 ×	Installation user manual
1 ×	CD/DVD with manual
1 ×	Device
1 ×	Terminal cable: M12 connector, 8-pin on DB9 socket
2 ×	50-Ω terminators for equipping free antenna connections (for device variants with 1 wireless module exclusively)
3 ×	50-Ω terminators for equipping free antenna connections (only for device variants with 2 wireless modules)
1 × for each power supply connection	2-pin terminal block for signal contact Note: With working voltage with the characteristic value P, the signal contact is omitted.
1 × for each power supply connection	2-pin terminal block for the working voltage (for device variants featuring working voltage characteristic value C or W exclusively)
1 × for each power supply connection	3-pin terminal block for the working voltage (for device variants featuring working voltage characteristic value K exclusively)
3 × per WLAN module	3-dBi dipole dual-band antennas for initial operation

Figure 10: List of accessories characteristic value Z

Number	Article
1 ×	Installation user manual
1 ×	CD/DVD with manual
1 ×	Device
1 × for each power supply connection	2-pin terminal block for the working voltage (for device variants featuring working voltage characteristic value C or W exclusively)
1 × for each power supply connection	2-pin terminal block for signal contact Note: With working voltage with the characteristic value P, the signal contact is omitted.
1 × for each power supply connection	3-pin terminal block for the working voltage (for device variants featuring working voltage characteristic value K exclusively)

Figure 11: List of accessories characteristic value 9

■ Accessories

Note: Please note that products recommended as accessories may have characteristics that do not fully correspond to those of the device. This may limit their possible usage in the overall system.

For optimum reception and transmission power, you need antennas suitable for the particular application. The BAT Planner of Hirschmann assists you in the selection of suitable antennas. You can obtain the BAT Planner for free at www.hirschmann.com.

The “Antenna Guide” document provides an overview of the antennas that can be used as well as the suitable antenna accessories.

This document is available as a PDF file on the enclosed CD/DVD or as a download from the Hirschmann product pages (www.hirschmann.com).

Gigabit Ethernet SFP transceiver	Order number
M-SFP-SX/LC	943 014-001
M-SFP-SX/LC EEC	943 896-001
M-SFP-LX/LC	943 015-001
M-SFP-LX/LC EEC	943 897-001
M-SFP-LH/LC	943 042-001
M-SFP-LH/LC EEC	943 898-001
M-SFP-LH+/LC	943 049-001

Note: IP67 V1 connector housings according to IEC 61076-3-106 (Variant 1) you will receive from BTR NETCOM GmbH.

Other accessories	Order number
AutoConfiguration Adapter ACA 21-USB	943 271-002
For device variants with the characteristic value C or W for the working voltage: 2-pin terminal block (50 pieces) for working voltage	943 845-009
For device variants with the characteristic value K for the working voltage: 3-pin terminal block (50 pieces) for working voltage	943 845-008
Network management software Industrial HiVision	943 156-xxx
Rail Power Supply RPS60/48V EEC	943 952-001
Rail Power Supply RPS 30	943 662-003
Rail Power Supply RPS 80 EEC	943 662-080
Rail Power Supply RPS 120 EEC (CC)	943 662-121
Terminal cable: M12 connector, 8-pin on DB9 socket	942 087-001
Wall mounting plate for DIN rail mounting, width 5.91 in. (150 mm)	943 971-004
2-pin terminal block (50 pieces) for signal contact	943 845-010
50-Ω terminators for equipping unused antenna connections, R-SMA (10 pieces)	942 117-001

■ Underlying technical standards

Name	
ATEX 95 (94/9/EG)	ATEX – Intended use of equipment and protection systems in in potentially explosive areas.
EN 45545-1	Railway applications - Fire protection on railway vehicles - Part 1: General
EN 45545-2	Railway applications - Fire protection on railway vehicles - Part 2: Requirements for fire behaviour of materials and components.
ECE Nr. 10	E type approval for use in vehicles
EN 50155	Railway applications - Electronic equipment used on rolling stock
EN 55022	Information technology equipment – Radio disturbance characteristics – Limits and methods of measurement
EN 60079-0	Explosive atmospheres – Part 0: Equipment – General requirements
EN 60079-15	Explosive atmospheres – Part 15: Equipment protection by type of protection „n“
EN 60529	Degrees of protection provided by enclosures – IP code.
EN 60950-1	Information technology equipment – Safety – Part 1: General requirements
EN 61000-6-2	Electromagnetic compatibility (EMC) – Part 6-2: Generic standards – Immunity for industrial environments
EN 61131-2	Programmable controllers – Part 2: Equipment requirements and tests
FCC 47 CFR Part 15	Code of Federal Regulations
FM3600	Approval Standard for Electrical Equipment for Use in Hazardous (Classified) Locations - General Requirements
FM3611	Approval Standard for Nonincendive Electrical Equipment for Use in Class I and Class II, Division 2, and Class III, Divisions 1 and 2, Hazardous (Classified) Locations
IEEE 802.1D	MAC Bridges (switching function)
IEEE 802.1Q	Virtual LANs (VLANs, MRP, Spanning Tree)
IEEE 802.1w	Rapid Reconfiguration
IEEE 802.11a/b/g/h/n	WLAN
IEEE 802.3	Ethernet
IEEE 802.3af	Power over Ethernet

Table 27: List of norms and standards

The device has an approval based on a specific standard or de facto standard solely if the approval indicator appears on the housing. If your device has a shipping approval according to Germanischer Lloyd, you find the approval mark printed on the device label. You will find out whether your device has other shipping approvals on the Hirschmann website under www.hirschmann.com in the product information. The device generally fulfills the norms and standards named in their current versions.

A Further Support

■ Technical Questions

For technical questions, please contact any Hirschmann dealer in your area or Hirschmann directly.

You will find the addresses of our partners on the Internet at <http://www.hirschmann.com>

Contact our support at <https://hirschmann-support.belden.eu.com>

You can contact us

in the EMEA region at

- ▶ Tel.: +49 (0)1805 14-1538
- ▶ E-mail: hac.support@belden.com

in the America region at

- ▶ Tel.: +1 (717) 217-2270
- ▶ E-mail: inet-support.us@belden.com

in the Asia-Pacific region at

- ▶ Tel.: +65 6854 9860
- ▶ E-mail: inet-ap@belden.com

■ Hirschmann Competence Center

The Hirschmann Competence Center is ahead of its competitors:

- ▶ Consulting incorporates comprehensive technical advice, from system evaluation through network planning to project planning.
- ▶ Training offers you an introduction to the basics, product briefing and user training with certification.

The current technology and product training courses can be found at <http://www.hicomcenter.com>

- ▶ Support ranges from the first installation through the standby service to maintenance concepts.

With the Hirschmann Competence Center, you have decided against making any compromises. Our client-customized package leaves you free to choose the service components you want to use.

Internet:

<http://www.hicomcenter.com>



HIRSCHMANN

A **BELDEN** BRAND