



# XMT1200MS USER MANUAL

## TOOLS NEEDED



## PACKAGE CONTENTS

Before starting assembly, verify that all parts are included and undamaged. If any parts are missing or damaged, do not return the item to your dealer; contact customer service number listed on the back cover. Never use damaged parts.

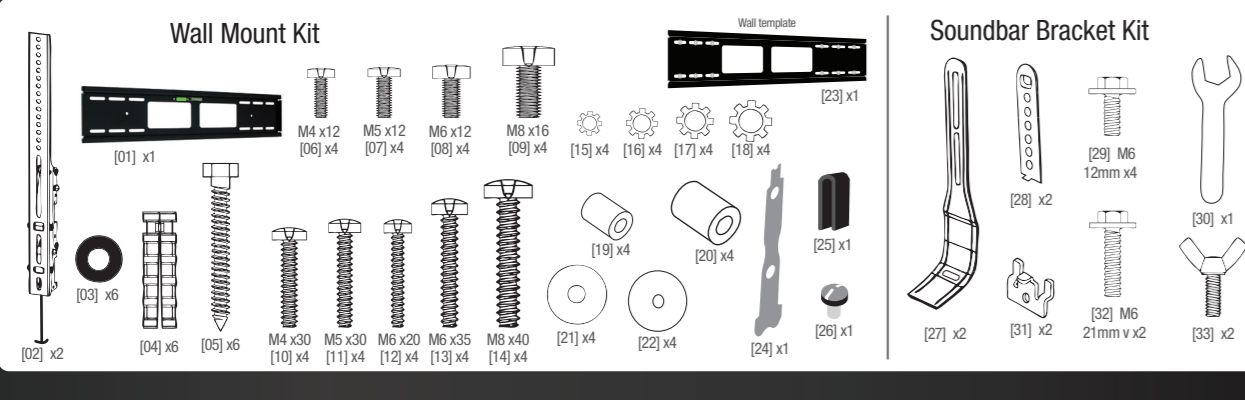

## 1A MOUNTING TO WALLS WITH WOOD STUDS

**CAUTION:** You must attach the TV wall mount to a wall that has at least 2" x 4" wood studs to avoid property damage or injury.

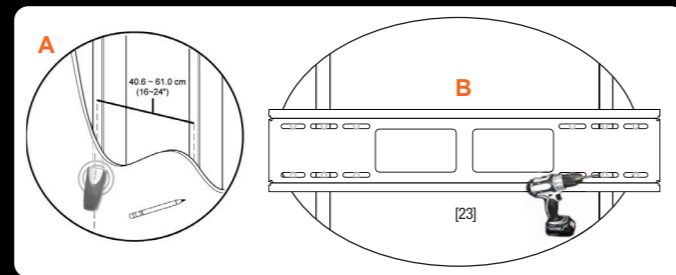

**A. Locate wall studs**  
1. Using a stud finder, locate two wood studs that are 16" to 24" apart.  
2. With a pencil, mark the location of the studs.

**B. Mark and drill holes**  
1. Tape the included Wall Mount Template to the wall so the holes align with the studs. Hold the wall plate [1] up to the Wall Mount Template and use the built-in level to make sure the Wall Mount Template is level. Put the wall plate [1] aside.  
2. Drill 4 holes with the 7/32" drill bit, 2-1/2" deep. Remove the Wall Mount Template.

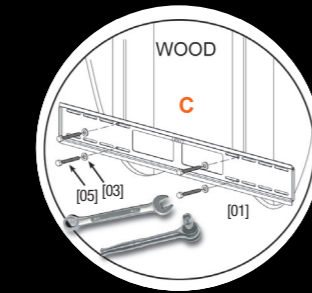

**C. Anchor mount to wall**  
1. Using a 1/2" wrench or socket, attach the wall plate [1] to the wall with the supplied lag bolts and washers [05] & [03].  
2. Use the level before tightening bolts.  
Note: It is important to make sure the wall plate is level.  
Note: Do not over-tighten lag bolts. Tighten only until they are firmly against the wall plate.

## 1B MOUNTING TO SOLID CONCRETE WALLS

**CAUTION:** Concrete anchors must be flush with the concrete surface.

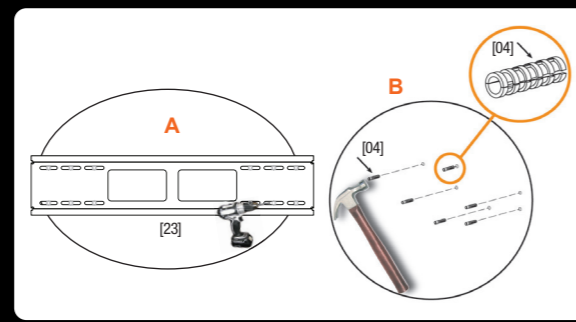

**A. Mark and drill holes**  
1. Tape the included Wall Mount Template to the wall. Hold the wall plate [1] up to the Wall Mount Template and use the built-in level to make sure it is level. Put the wall plate [1] aside.  
2. Drill 6 holes with a 1/2" masonry bit, 2-1/2" deep where indicated. Remove the Wall Mount Template.

**B. Install anchors**  
1. Install the provided anchors [04] in the holes, flush with the wall so that the hinged end faces out.

## 1B MOUNTING TO SOLID CONCRETE WALLS (continue)

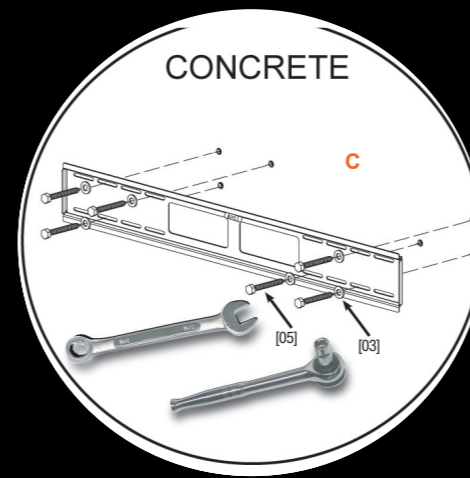

**C. Anchor mount to wall**  
1. Using a 1/2" wrench or socket, attach the wall plate [1] to the wall with the supplied lag bolts and washers [05] & [03].  
2. Use the level before tightening bolts.

Note: It is important to make sure the wall plate is level.  
Note: Do not over-tighten lag bolts. Tighten only until they are firmly against the wall plate.

## 2 ATTACH THE SCREEN BRACKETS

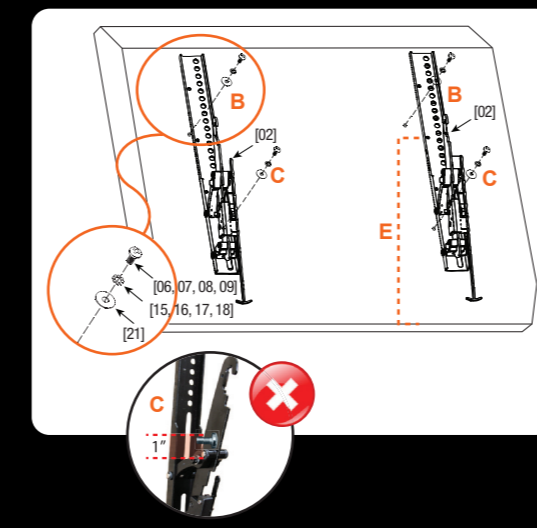

**A.** Lay the TV face down on a clean, flat surface.  
**B.** Center the brackets [02] on the TV leaving a 1/2" clearance from the bottom of the TV to the bottom of the quick release latch. **NOTE: There are two screws on the side of the quick release latch that can be removed to adjust its length.** Insert screws [06, 07, 08, or 09] and washers [15, 16, 17, or 18 & 21] to attach the top portion of the bracket to the TV.  
**C.** Raise the bracket hinge to reveal two elongated holes that can be used to connect the bottom portion of the bracket. Insert the screws [06, 07, 08, or 09] and washers [15, 16, 17, or 18 & 21] anywhere along these two holes but refrain from using the lower half portion of the top elongated hole as it interferes with the tilt mechanism.  
**D.** Fully tighten the screws.  
**E.** Measure the distance from the small hole that lies to the left of the bracket hook to the bottom of the TV. Be sure to account for any curvature the bottom of the TV may have. This length cannot exceed 14.5" and will be used to adjust the Soundbar bracket length for an appropriate fit.

## 3 ASSEMBLE SOUNDBAR BRACKETS

**A.** When assembling the Soundbar bracket, the length from the top of the square hole on the top bracket [28] to the indicated lower mid-section on the curved bracket [27] should be adjusted to equal the length measured in step 2E. The images on the right are an example of a possible assembly setup.  
**B.** Attach the top bracket [28] to the back of the curved bracket [27] by inserting the short bolt [29] into any of the holes in the top bracket. The higher the hole, the shorter the length of the overall bracket, and vice versa. Make sure the hooks of the top bracket [28] face away from the curved bracket [27] and point up. DO NOT fully tighten the bolt.  
**C.** The bracket length can be further adjusted by sliding the brackets while the bolt is attached. Once the desired location is obtained, fully tighten the bolt.  
**D.** Attach the bottom bracket [31] to the back of the curved bracket [27] by inserting the short bolt [29]. The top tip of the bottom bracket [31] should always be placed directly beneath the top bracket [28] unless the middle divider prevents this. Make sure the hooks of the bottom bracket [31] face away from the curved bracket [27] and point up. DO NOT fully tighten the bolt.  
**E.** The long bolt [32] is used to stabilize the Soundbar and depending on your configuration can be screwed into any hole of the top bracket [28] and may or may not go through the curved bracket [27] but it MUST make contact with the wall plate [1] behind. DO NOT fully tighten the bolt yet.  
**F.** Repeat the above steps with the other bracket.

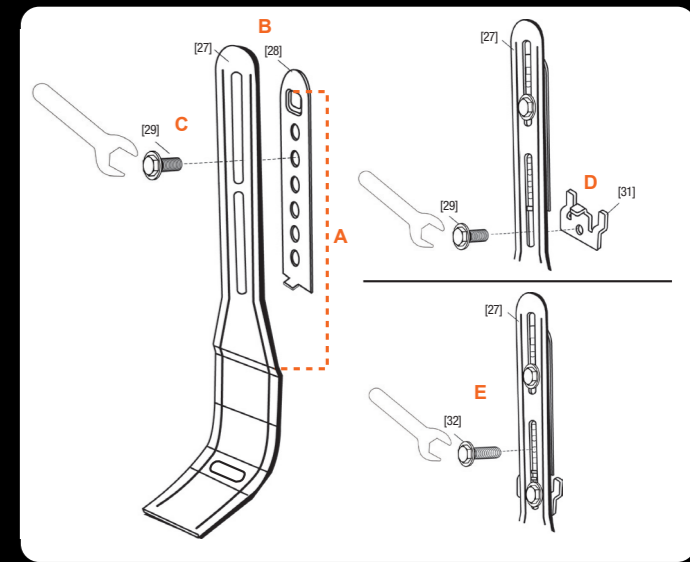

## 4 ATTACH SOUNDBAR BRACKET TO SOUNDBAR

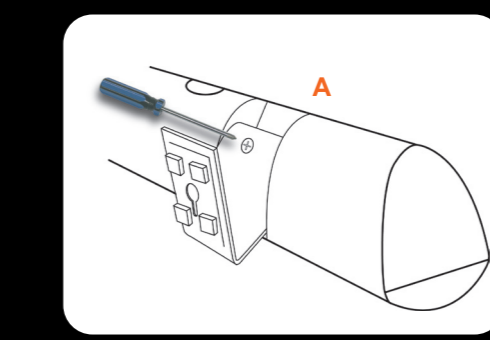

**A.** Remove the stands from the Soundbar by removing the screw. Use a Phillips screwdriver to loosen it if needed.

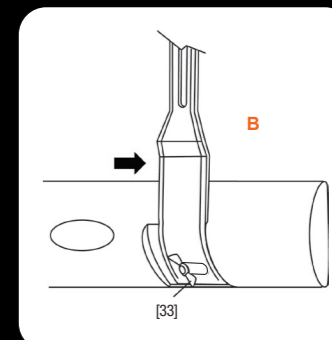

**B.** Align the Soundbar you assembled in the previous step with the outside edges of the opening in the Soundbar and secure with the wing screw [33].

## 5 ATTACH SOUNDBAR BRACKETS TO WALL PLATE

**A.** Anchor the top bracket hooks [28] to the top rail of the wall plate [01]. Position the Soundbar to the desired location on the wall plate.  
**B.** Slide the bottom bracket hooks [31] up until they are anchored on the bottom rail of the wall plate.  
**C.** Hold the hooks firmly in place while you tighten them with the wrench [30].  
**D.** Tighten all of the bolts. Do not over tighten.  
**E.** Remove the Soundbar by unscrewing the wing screws [33]. We had you attach it to set the width of the brackets. You will reattach it later, after the TV has been mounted.

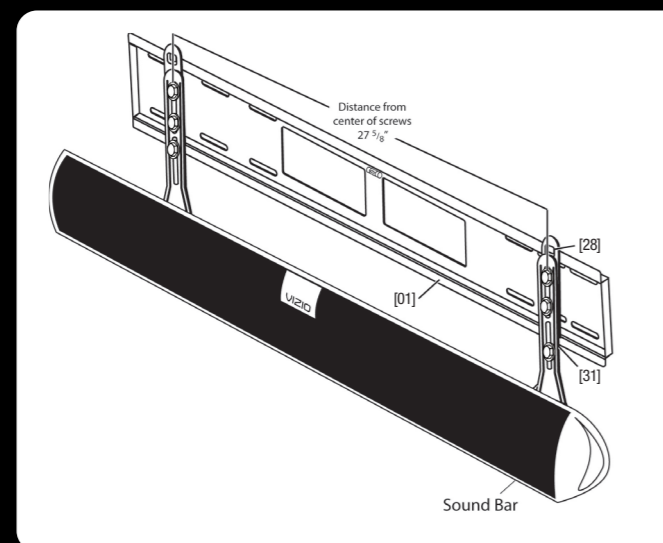

## 6 CONNECT CABLES TO TV

**A.** Connect one end of the Soundbar RCA Stereo cable to the AV1 Audio L/R jacks on the TV. Do not connect the other end of the audio cable to the Soundbar yet. You will do that after the TV is mounted on the wall.  
**B.** Connect the power cable to the back of the TV. Do not connect the power cable to the wall outlet yet. You will do that after the TV is mounted on the wall.  
**C.** See the documentation that came with the TV to connect the cables needed for any device (i.e. DVD player, cable box, etc.) you want to connect to the TV. Do not connect the other end of the cables to the devices yet. You will do that after the TV is mounted on the wall.

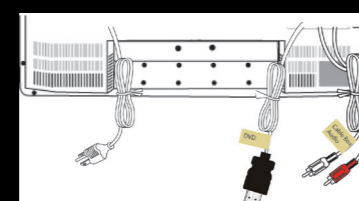

TIP: Create and attach labels to the cables, identifying the cables to make it easier to later connect the cables to the devices.

## 7 ATTACH TV TO WALL PLATE

**CAUTION:** For safety, we recommend having two people lift the TV onto the mount.

**A.** Lift the TV onto the wall plate [1].  
**B.** Center the TV between the Soundbar brackets.

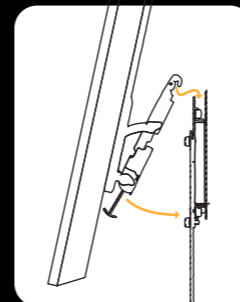

## 8 SECURITY LOCK FEATURE

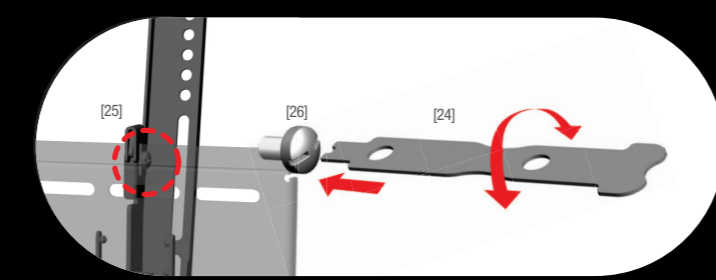

Prevent theft by applying security screws (key included).

## 9 REATTACH SOUNDBAR TO BRACKETS

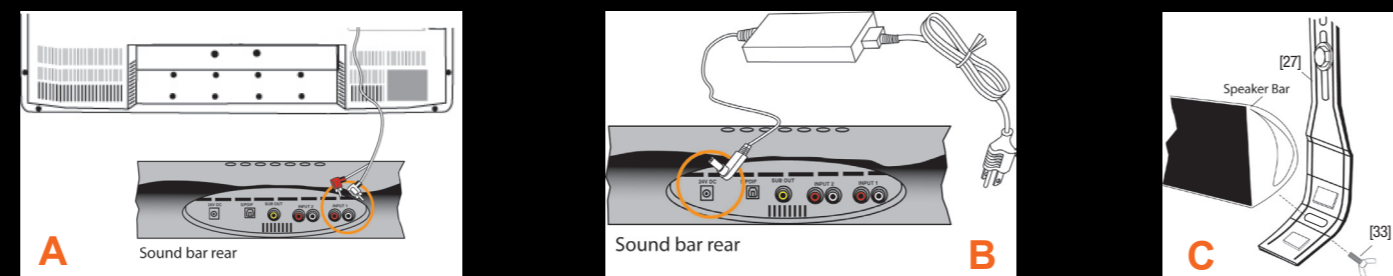

**A.** Connect the other end of the Soundbar RCA Stereo cable that is hanging down from the TV to the INPUT 1 jacks on the Soundbar.  
**B.** Connect one end of the Soundbar AC adapter into the 24V DC jack on the back of the Soundbar.  
**C.** See the documentation that came with the Soundbar to connect other audio devices to the Soundbar. Reattach the Soundbar to the brackets using the wing screws [33].  
Note: If the Soundbar is not level with the TV, slightly unscrew the screws [29 & 32] using the wrench [14] then reposition the Soundbar and re-tighten the screws.

## 10 CONNECT CABLES AND POWER

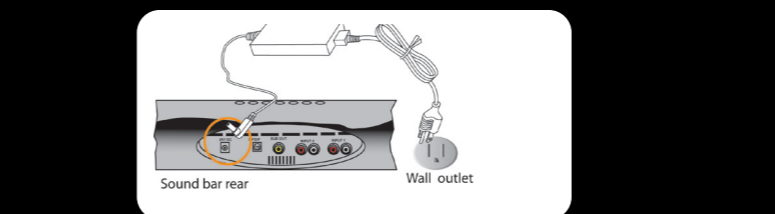

**A.** Connect the other ends of the cables that are hanging from the TV to the appropriate devices (i.e. DVD player, cable box, etc.).  
**B.** Connect the other end of the Soundbar AC adapter into a wall outlet.

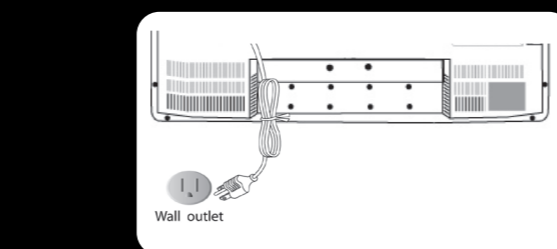

**C.** Connect the other end of the TV power cable into a wall outlet.

## 11 TIGHTEN SAFETY SCREWS

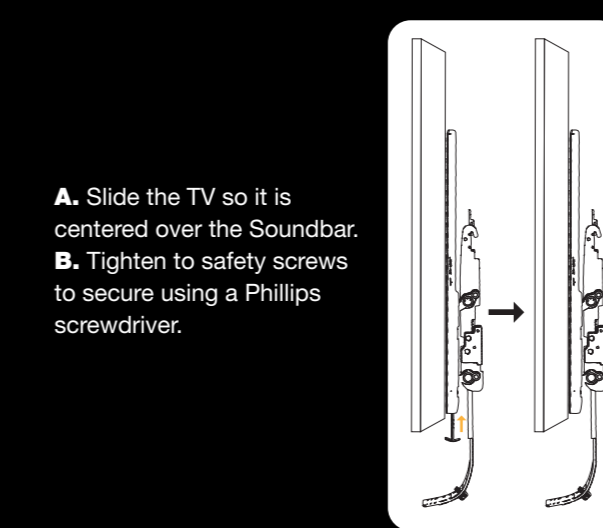

**A.** Slide the TV so it is centered over the Soundbar.  
**B.** Tighten to safety screws to secure using a Phillips screwdriver.

## IMPORTANT SAFETY INSTRUCTIONS

When using this tilt mounting system, basic precautions should be followed, including:

- Follow the entire installation/user's manual and the important safety instructions before attempting to install or use this mounting system.
- Manufacturer is not liable for damage or injury caused by incorrect mounting, assembly, or use.
- If you have any doubts about the ability of the wall to support the TV and the mounting system, contact a qualified contractor.
- This mount and Soundbar bracket bundle supports screens from 37" to 47".
- The maximum screen and weight this mounting system can support is 60" and not more than 120 lbs (54 Kg).
- Attaching a screen that is heavier than the maximum weight specified above may result in instability, and possible personal injury.
- Only attach this mount system on vertical walls as instructed in this manual.
- If you have any doubts about the ability of the wall to support the TV and the mounting system, contact a qualified contractor.
- This product contains small items that could be a choking hazard if swallowed.
- Keep these items away from children.
- For indoor use only.

## TELEPHONE AND TECHNICAL SUPPORT

For technical assistance contact our VIZIO Technical Support Department via email or phone.  
Email: techsupport@vizio.com  
(877) 698-4946 Fax: (949) 585-9563  
Hours of operation: Monday - Friday: 6 am to 9 pm  
Saturday - Sunday: 8 am to 4 pm

Please have your VIZIO model number, serial number, and date of purchase available before you call.  
**VIZIO**  
39 Tesla • Irvine, CA 92618, USA  
Telephone: (949) 428-2525 Fax: (949) 585-9514  
Web: www.vizio.com

## ONE-YEAR LIMITED WARRANTY & INSURANCE

Covers units purchased as new in United States and Puerto Rico. Only VIZIO warrants for a period of one (1) year from the date of purchase to the original purchaser of its mounting brackets, that the bracket shall be free from defects in assembly, material, or workmanship and will repair or replace, at its sole discretion, a defective bracket free of charge, provided the bracket is returned to VIZIO with shipping prepaid by purchaser. Unauthorized service or repairs by anyone other than VIZIO or a pre-approved repair facility renders this warranty void and shall release VIZIO from any further responsibility or obligation.

Insurance: VIZIO will repair or replace up to a maximum of \$10,000.00, at its option, any component (television, projector, monitor or screen) which is damaged by a VIZIO bracket's failure to perform when that product is properly installed for its intended use. This insurance is subject to the limitations and exclusions set forth herein. VIZIO will repair or replace the damaged television, monitor or screen ("Component") at VIZIO's option, up to an amount equal to the fair market value of the damaged Component or the original purchase price of the equipment, whichever is less, up to \$10,000.00.

Other Terms & Conditions: VIZIO reserves the right to inspect the damaged component, the VIZIO bracket alleged to have failed, and the site where the damage occurred. Damaged Components and bracket must remain available for inspection until the claim is finalized. VIZIO may require you to ship, at your expense, the VIZIO bracket and damaged Component to VIZIO for inspection. VIZIO reserves the right to allocate the costs of repair. VIZIO determines, in its sole discretion, that it is impractical to ship the damaged component or bracket. VIZIO may designate, in its sole discretion, a component repair facility to inspect and estimate the cost to repair. The cost, if any, of shipping the Component to and from such repair facility and of such estimate shall be borne solely by the purchaser. Whenever claims are settled, VIZIO reserves the right to be subrogated under any existing insurance policies the claimant/purchaser may have.

The protections described herein shall be IN LIEU of any other warranty, express or implied, including but not limited to, any warranty of MERCHANTABILITY or FITNESS FOR A PARTICULAR PURPOSE. In no event shall VIZIO be liable for incidental, special, direct, indirect, consequential or multiple damages such as, but not limited to, lost business or profits arising out of the sale, use or inability to sell or use any VIZIO products, even if advised of the possibility of damages. This Limited Warranty & Insurance gives you specific legal rights, and you may also have other rights, which may vary from state to state. Some states do not allow the exclusion or limitation of incidental or consequential damage so the above limitations may not apply to you. This Limited Warranty & Insurance is valid only for the original purchaser of the product and only if the original purchaser registers the purchase on-line at www.vizio.com or by mailing a copy of the purchase receipt (showing the date of purchase) and product warranty registration card to VIZIO, 39 Tesla, Irvine, CA 92618. All damage claims must be made to VIZIO within fifteen (15) days from the date of the occurrence and must be accompanied by the purchase receipt for the damaged bracket or this Limited Warranty & Insurance as well. This Limited Warranty & Insurance is only valid in USA and Canada. To make a warranty or insurance claim, please call (877) MY VIZIO (877-688-4848) within fifteen (15) days of the occurrence. Please provide to us or have the following information available:

- a. The date of the occurrence and the part number of the VIZIO bracket involved.
- b. The Component that was used with the VIZIO bracket at the time of the occurrence.
- c. The Component that was damaged during the occurrence and the extent of the damage.
- d. A detailed description of any additional damage from the occurrence.
- e. A legible copy of the original receipt showing the place and date of purchase of the VIZIO bracket.
- f. A legible copy of the original receipt for the damaged Component.
- g. Photos (if any) of the damaged bracket.
- h. Serial number which is located on the carton box and the wall plate.

\* All above warranties and insurance are null and void if: the VIZIO bracket is used during the occurrence in any manner not provided for in the user's manual; the VIZIO bracket is not used in accordance with the instructions; the VIZIO bracket has been tampered with, altered in any way or tampered with; or if it is determined by VIZIO that the damage did not result from the VIZIO product's failure or that in fact no occurrence took place; or the repair or replacement of the damaged Component is covered under a manufacturer's warranty; or VIZIO determines that the Component was not used under normal operating conditions or in accordance with any labels or instructions. Improper installation voids this Limited Warranty & Insurance. VIZIO's Limited Warranty & Insurance only protects against:  
\*\* Failure to perform in accordance with that bracket's specifications sheet or product manual.  
\*\*\* Properly installed in accordance with that bracket's installation instruction sheet or bracket manual and only when mounted on approved surfaces.  
\*\*\*\* VIZIO reserves the right to require additional supporting evidence to substantiate any additional damage claims.