

# Operator Control and Monitoring Devices

## Mobile Panels - 170 Series

### SIMATIC Mobile Panel 170

#### Overview



- Mobile operator panel for direct operation of machines and plants from any location
- Provides an optimum view of the workpiece or the process and, at the same time, direct access and view of the operator unit
- Flexible use due to simple reconnection during operation
- Pixel graphics 5.7" color STN Touch Screen (analog/resistive), 16 colors
- 14 freely-configurable and freely-inscribable function keys (8 with LEDs)
- Two 3-level enabling keys;  
Optional versions with:
  - STOP keys
  - STOP keys, handwheel, key switches and illuminated push-button units
- Connection to the PLC and power supply is via the connection box and connecting cable

#### Benefits

- Hot swapping during normal operation without interruption of the emergency stop circuit (with junction box Plus) and without causing any bus errors
- Fast, accurate set up and positioning
- Reliable operation with well-proven safety system concept (Safety Category 3 to EN 954-1)
- Ergonomic and compact with low weight (approx. 1.3 kg)
- Rugged for industrial use
- Can be used worldwide:
  - 21 languages can be configured (including Asiatic and Cyrillic character sets)
  - Up to 5 languages are selectable online

#### Area of application

SIMATIC Mobile Panels are suitable for industrial applications in all sectors. They can be used wherever mobile, on-site operation of machines and plants is required: for example with larger production plants, complex or encapsulated machines, long transfer or production lines, or with conveying technology.

#### Design

- Ergonomic and compact with various holding and gripping positions (suitable for right-handed and left-handed persons)
- Pixel graphics 5.7" color STN Touch Screen (analog/resistive)
- 14 freely-configurable and freely-inscribable function keys (8 with LEDs)
- The product is resistant to various oils, greases and standard detergents
- Two 3-level enabling keys
- Optional product versions with
  - STOP button or
  - STOP button, handwheel, key switch and illuminated push-buttonThe STOP button is secured with a protective collar.  
If the STOP button is looped into the emergency stop circuit, it will have the functionality of an emergency stop pushbutton.
- Extremely resistant to shock thanks to the double wall construction and the round housing shape (they will survive a fall from a height of 1.5 m without any damage)
- Dust-tight and splashproof housing to the IP 65 degree of protection
- Integrated, serial, MPI and PROFIBUS interface (up to 12 Mbit/s)
- Slot for one Compact Flash card (CF card)
- Connection to the control via the reliable and rugged junction box to the IP 65 degree of protection:
  - Junction box Basic: allows the STOP button to be integrated into the safety circuit
  - Junction box Plus: allows the STOP button to be integrated into the safety circuitThe emergency stop circuit always remains closed irrespective of whether the mobile panel is connected or not. Monitoring of the STOP button is possible.

#### Proven safety concept

The two enable keys (to EN 60204-1) with three switching steps each, guarantee the protection of man and machine in critical situations. They are integrated in the rear handle.

The STOP button (to EN 60204-1) is hard-wired and latches positively when operated. It can be looped into the emergency stop circuit of a monitored system in which case it has the functionality of an emergency stop pushbutton, but it differs with respect to its gray color. There is therefore no danger of confusion with an emergency stop device. This is particularly important if the mobile control unit is not connected to the machine. SIMATIC Mobile Panels make it possible to provide safety functions at any point of a machine or system.

STOP and enabling switches are designed with dual circuits according to the safety directives, and meet the requirements of safety category 3 to EN 954-1.

### Design (cont.)

#### Innovative connection concept

The mobile panel is simply connected to the junction box where required in the system or on the machine, and is immediately available for use. The junction box can be mounted anywhere, also outside the control cabinet. It guarantees fault-free hot swapping, making it possible to swap the operating locations simply and reliably if there are several connection points in a system or machine. The mobile panel can be configured such that the associated user-interface is selected depending on the connection point.

#### Configuration options with looping into emergency stop

The versions with STOP switches can be incorporated into the emergency stop circuit of a machine or system via the junction boxes. Pressing the STOP switch on the mobile panel then triggers the emergency stop. The STOP switch on the mobile panel supplements the emergency stop device according to EN 418 which is fixed to the machine, but does not replace it. When disconnecting the mobile panel, the junction box Plus automatically closes the emergency stop circuit, thus ensuring safe, fault-free operation when swapping its connection point.

#### Connection at one point of the machine

If a junction box Basic is used, disconnecting of the mobile panel results in opening the emergency stop circuit, and thus triggering of the emergency stop function. This configuration is therefore suitable for connecting the mobile panel to a fixed point on the machine.

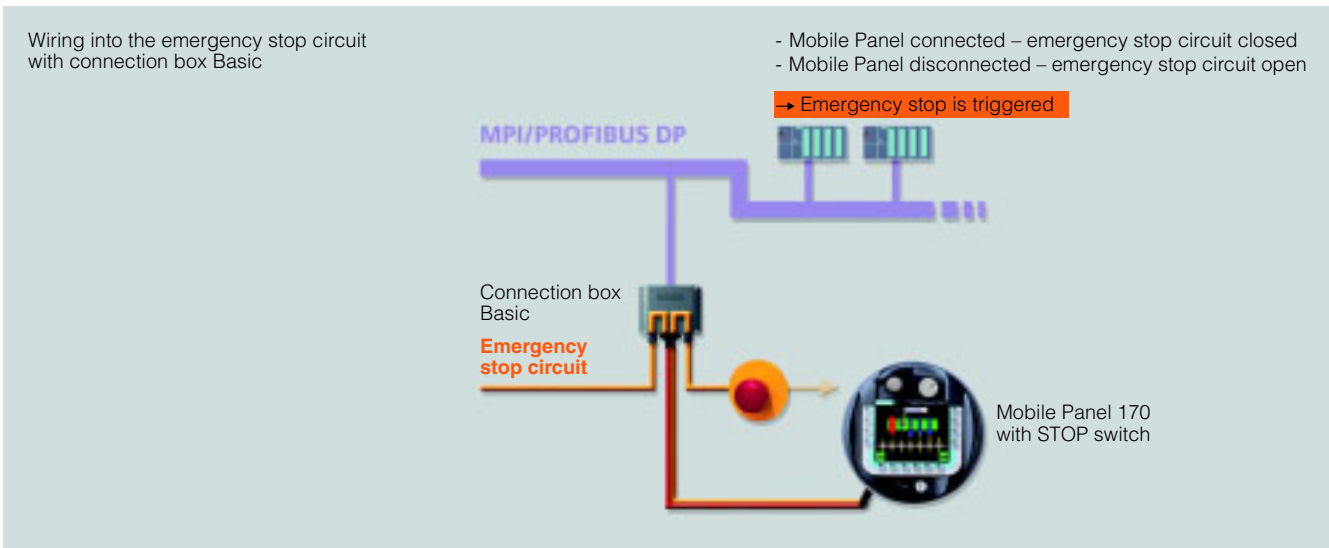

#### Variable connection to different stations of a machine or system

If a Mobile Panel 170 with STOP switch is used together with the junction box Plus, it is possible to design a configuration in which the mobile panel can be used variably and is looped into the emergency stop circuit at the same time. The emergency stop circuit remains closed irrespective of whether the mobile panel is connected or disconnected. When the mobile panel is con-

nected, the STOP button is looped into the emergency stop circuit, when the STOP button is pressed, the circuit is opened and the emergency stop function is activated. If the mobile panel is disconnected during operation, the emergency stop circuit in the junction box Plus is automatically closed.

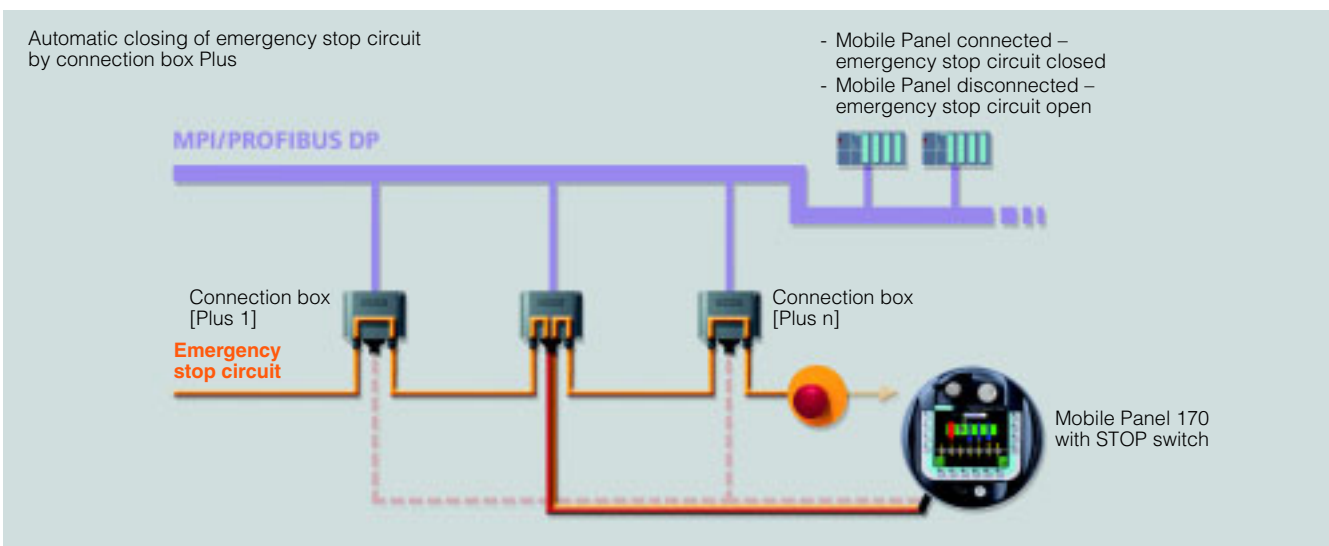

# Operator Control and Monitoring Devices

## Mobile Panels - 170 Series

### SIMATIC Mobile Panel 170

#### Functions

- Input/output fields for displaying and changing process parameters
- Function keys for direct initiation of functions and actions. Up to 16 functions can be configured simultaneously on function keys. The function keys can be used directly as PROFIBUS DP input peripherals.
- Control elements (handwheel, key switch and illuminated pushbutton) can be used directly as PROFIBUS DP input peripherals
- Direct control of the additional operating elements (handwheel, key-operated switch and illuminated pushbutton) as PROFIBUS DP input periphery (DP direct keys)
- Buttons for direct initiation of functions and actions. Up to 16 functions can be configured simultaneously on buttons.
- Graphics can be used as ICONs instead of text to label function keys or buttons. They can also be used as background displays (wallpaper). In the configuration tool, a library is available containing extensive graphics and a wide variety of objects. All editors with an OLE interface can be used as graphics editor (such as Paint Shop, Designer or CorelDraw).
- Vector graphics; basic geometric shapes (e.g. lines, circles and rectangles) can be created direct in the configuration tool
- Fixed texts for labeling function keys, process diagrams and process values in any character size
- Curve functions and bar charts are used to visualize dynamic values
- Display selection from the PLC supports operator prompting from the PLC
- Language selection; 5 online languages, 21 configuration languages incl. Asiatic and Cyrillic character sets
- Password protection with 10 levels
- Message system; administration of operating, fault and system messages
- Recipe management
  - With additional data storage (on CF card)
  - Online/offline editing on the panel
  - Storing of recipe data in standard Windows format (CSV)
  - External processing with standard Excel and Access tools
- Help texts for process diagrams, messages and variables
- Mathematical functions
- Limit value monitoring for reliable process control of inputs and outputs
- Indicator light for machine and plant status indication
- Interval timer for cyclic function processing
- Print; hardcopy and messages (see "recommended printers")
- Dynamic positioning of objects and dynamic hiding and showing of objects
- Permanent window; permanently defined screen area for outputting general information (e.g. important process variables, date and time)

- Simple maintenance and configuration through
  - Backup and restoring the configuration, operating system, data records and firmware on the optional CF card (Compact Flash card)
  - Backup and restoring the configuration, operating system, data records and firmware on a PC using ProSave
  - Downloading/uploading the configuration via MPI/PROFIBUS DP/RS232 or CF Card
  - Automatic transfer identification
  - Individual contrast settings
  - Configuration simulation directly on the configuration computer
  - No batteries are necessary

#### Configuration

Configuring is performed using the configuration software SIMATIC ProTool/Lite, SIMATIC ProTool or SIMATIC ProTool/Pro Configuration Version 6.0 SP2 upwards (see configuration or visualization software).

#### Integration

Communication with the PLC is via PROFIBUS DP at up to 12 Mbit/s, via MPI, or via the serial interface. The interfaces are already integrated. The cable can be up to 10 meters long. A wide range of drivers – also for third-party PLCs – are included in the standard scope of supply. The handwheel, keyswitch and illuminated pushbutton are directly controlled via a DP I/O (DP direct key function).

The junction box allows the mobile panel to be connected to:

- SIMATIC S7:S7-200/-300-400
- SIMATIC WinAC Software/Slot PLC
- SIMOTION
- SIMATIC S5
- SIMATIC 505
- Third-party controllers
  - Allen Bradley
  - Mitsubishi
  - Telemecanique
  - Modicon Modbus
  - GE-Fanuc
  - Lucky Goldstar GLOFA
  - OMRON



#### Note:

For further information see "System interfaces"

# Operator Control and Monitoring Devices

## Mobile Panels - 170 Series

SIMATIC Mobile Panel 170

2

### Technical specifications

Type	Mobile Panel 170
<b>Display</b>	STN liquid crystal display (LCD)
• Size in inches / W x H in mm	5.7" / 116 x 87
• Resolution (pixels)	320 x 240
• Colors	16 colors
• MTBF of backlighting (at 25°C)	Approx. 50000 hours
<b>Control elements</b>	
• Type of operator control	Touch and keys
• Programmable, freely inscribable function keys	14 (8 with LED)
• Numeric/alphanumeric input	Yes/yes
• Enabling button (EN 60204-1)	2-channel, 3-stage
• STOP button (EN 60204-1)	Optional, 2-channel, forced blocking, can be looped into the emergency stop circuit
• Keyswitch	Optional, 3 switching positions
• Illuminated pushbutton	Optional
• Handwheel	Optional
<b>Expansions for operator control of the process</b>	
• DP direct keys/LEDs (OP keys/LEDs as I/O peripherals)	F1...F14
• DP direct keys/LEDs (TP buttons as I/O peripherals)	4-byte or encoded
<b>Operating system</b>	Win CE
<b>Memory</b>	
• Type	Flash / RAM
• Useable memory for user data	768 KB
<b>Interfaces</b>	2 x RS232, 1 x RS422, 1 x RS485 max. 12 Mbit/s
• CF card slot	1 x CF card slot
<b>Interface with PLC</b>	S5, S7-200, S7-300/400, 505, WinAC Soft-PLC/Slot-PLC (V 3.0 upwards), SIMOTION, Allen Bradley (DF1), Mitsubishi (FX), Telemecanique (Uni-Telway), Modicon (Modbus), further PLCs from other vendors
<b>Clock</b>	Hardware clock, unbuffered, synchronized
<b>Supply voltage</b>	Via junction box
<b>Degree of protection</b>	IP 65
<b>Ambient conditions</b>	
• Temperature	
- Operation	0 °C to 40 °C
- Transport, storage	-20 °C to 60 °C
• Relative humidity, max.	80 %

Type	Mobile Panel 170
<b>Dimensions</b>	
• External dimensions in mm	W 245 / D 58
<b>Weight (kg)</b>	1.3
<b>Certification</b>	cULus, CE, SIBE
<b>Functions</b>	
Message system	
• Operating messages	1000
• Fault messages	1000
• System messages	Yes
• Message length (lines x characters)	1 x 70
• Message buffer	Circulating buffer, 256 each, no battery back-up
Recipes	100
• Records per recipe	200
• Entries per record	200
• Recipe memory	32 KB integrated flash, expandable
Process diagrams	100
• Text objects	2000 text elements
• Graphics objects	Bitmaps, icons, background images, vector graphics
• Dynamic objects	Graphs, bars, hidden buttons
- Libraries	Yes
Variables	1000
Password protection (levels)	10
Printer functions	Hardcopy, messages
Online languages	5
• Project languages	Danish, German, traditional Chinese, simplified Chinese, English, Finnish, French, Greek, Italian, Japanese, Korean, Dutch, Norwegian, Polish, Portuguese, Russian, Swedish, Spanish, Czech, Turkish, Hungarian
Character set	Tahoma, freely scalable
Help text	Yes
Timer	Yes
<b>Configuration tool</b>	ProTool/Lite Version 6.0 SP2 upwards, executable under Windows 98/SE/ME/NT/2000/XP Professional (must be ordered separately)
• Configuration transfer	Serial / MPI / PROFIBUS DP / automatic transfer detection

Type	Junction box Basic:	Junction box Plus:
Ports	1 x RS232, 1 x RS422, 1 x RS485 max. 12 Mbit/s	1 x RS232, 1 x RS422, 1 x RS485 max. 12 Mbit/s
Expansions for operator control of the process		
• Hot swapping	With interruption in emergency stop circuit	Without interruption in emergency stop circuit
• Monitoring of the STOP button	No	Yes
• Location identification	Yes	Yes
Housing degree of protection	IP 65	IP 65
Power supply	24 V DC	24 V DC
Dimensions		
• External dimensions W x H x D (mm)	160 x 120 x 70	160 x 120 x 70
Weight	0.35 kg	0.4 kg
Ambient conditions		
• Temperature		
- Operation (vertical installation)	0 °C to +50 °C	0 °C to +50 °C
- Transport, storage	-20 °C to +70 °C	-20 °C to +70 °C
• Relative humidity, max.	85 %	85 %

# Operator Control and Monitoring Devices

## Mobile Panels - 170 Series

### SIMATIC Mobile Panel 170

#### Ordering Data

	Order No.
<b>SIMATIC Mobile Panel 170</b>	
• With integrated enabling button	<b>6AV6 545-4BA16-0CX0</b>
• With integrated enabling button and STOP button	<b>6AV6 545-4BB16-0CX0</b>
• With integrated enabling button, STOP button, handwheel, keyswitch and illuminated push-button	<b>6AV6 545-4BC16-0CX0</b>
<b>Junction box</b>	
• Basic	<b>6AV6 574-1AE04-4AA0</b>
• Plus	<b>6AV6 574-1AE14-4AA0</b>
<b>Connection cable</b>	
• 5m	<b>6XV1 440-4AH50</b>
• 10m	<b>6XV1 440-4AN10</b>
<b>Wall bracket for Mobile Panel 170</b>	<b>6AV6 574-1AF04-4AA0</b>
<b>Starter package Basic</b>	<b>6AV6 575-1AJ06-0CX0</b>
• Mobile Panel 170 with integrated enabling button	
• Junction box Basic:	
• Connection cable, 10m	
• Wall bracket	
• SIMATIC ProTool/Lite	
• Documentation CD, 5-language (English, French, German, Italian, Spanish)	
• Software update service for 1 year	
<b>Starter package Plus</b>	<b>6AV6 575-1AJ16-0CX0</b>
• Mobile Panel 170 with integrated enabling button, STOP button, handwheel, keyswitch and illuminated pushbutton	
• Junction box Plus	
• Connection cable, 10m	
• Wall bracket	
• SIMATIC ProTool/Lite	
• Documentation CD, 5-language (English, French, German, Italian, Spanish)	
• Software update service for 1 year	
<b>Configuration</b>	
with SIMATIC ProTool and SIMATIC ProTool/Pro	<b>see Section 4</b>

	Order No.
<b>Documentation (to be ordered separately)</b>	
<b>Manual Mobile Panel 170</b>	
• German	<b>6AV6 591-1DC30-0AA0</b>
• English	<b>6AV6 591-1DC30-0AB0</b>
• French	<b>6AV6 591-1DC30-0AC0</b>
• Italian	<b>6AV6 591-1DC30-0AD0</b>
• Spanish	<b>6AV6 591-1DC30-0AE0</b>
<b>Short startup guide for Mobile Panel 170</b>	
• German	<b>6AV6 591-1EC30-0AA0</b>
• English	<b>6AV6 591-1EC30-0AB0</b>
• French	<b>6AV6 591-1EC30-0AC0</b>
• Italian	<b>6AV6 591-1EC30-0AD0</b>
• Spanish	<b>6AV6 591-1EC30-0AE0</b>
<b>ProTool user manual Configuring Windows-based Systems</b>	
• German	<b>6AV6 594-1MA06-1AA0</b>
• English	<b>6AV6 594-1MA06-1AB0</b>
• French	<b>6AV6 594-1MA06-1AC0</b>
• Italian	<b>6AV6 594-1MA06-1AD0</b>
• Spanish	<b>6AV6 594-1MA06-1AE0</b>
<b>Communications manual for Windows-based systems</b>	
• German	<b>6AV6 596-1MA06-0AA0</b>
• English	<b>6AV6 596-1MA06-0AB0</b>
• French	<b>6AV6 596-1MA06-0AC0</b>
• Italian	<b>6AV6 596-1MA06-0AD0</b>
• Spanish	<b>6AV6 596-1MA06-0AE0</b>
<b>Accessories for reordering</b>	
<b>CF card, 16 MB</b>	<b>6AV6 574-2AC00-2AA0</b>
<b>Protective membrane</b>	
for protecting the touch front against dirt and scratches (pack of 10)	<b>6AV6 574-1AD04-4AA0</b>
<b>Protective envelopes</b>	
for labeling strips (pack of 5)	<b>6AV6 574-1AB04-4AA0</b>
<b>Service package</b>	<b>6AV6 574-1AA04-4AA0</b>
Comprising:	
• Blanking plug for cable inlet	
• 2 x Pg screwed cable gland for junction box	
• 1 set of screws for junction box cover	
• 2 x terminal box (12-pole)	

#### Dimension drawings

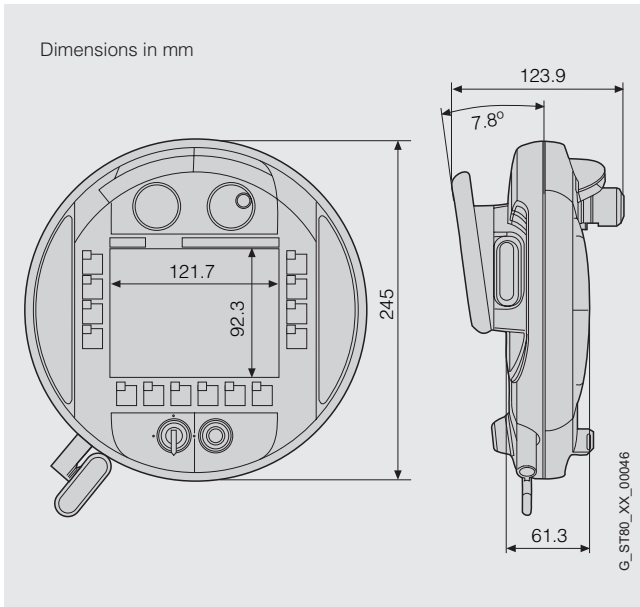

SIMATIC Mobile Panel front and side view

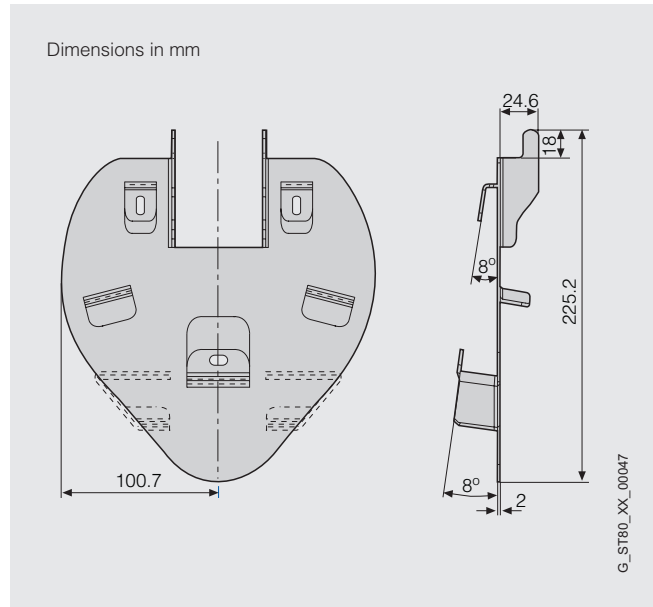

Wall mounting for SIMATIC Mobile Panel

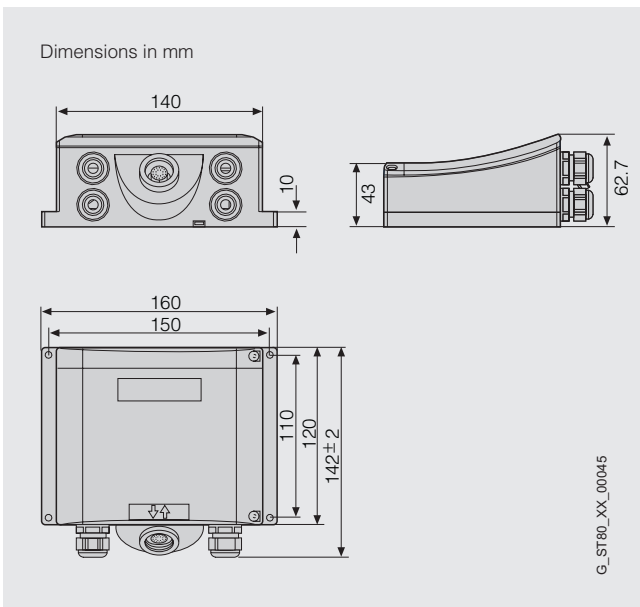

Connection box for SIMATIC Mobile Panel

#### Further Information

For further information, visit our website at



<http://www.siemens.com/mobile-panels>