



SFF 6135hfd

Register your product and get support at
www.philips.com/welcome

EN User Manual

PHILIPS

Introduction

EN

Dear Customer

With the purchase of this device, you have chosen a quality PHILIPS product brand. Their device fulfils the most varied requirements for private use or in your office and business everyday.

You use the power and toner saving functions to save electricity and toner, by switching the device to power saving mode or printing in toner saving mode. Use the **ECO-** button to make toner saving copies quickly and simply.

For printing purposes, your device utilises the most up-to-date laser printing technology. A starter cartridge is provided with the device. This starter cartridge is already installed; however you must remove the packaging used for transportation before you can use the device.

You can insert a supply of paper into the paper tray of up to 250 sheets. You can insert special paper formats, envelopes, slides, sheets of labels or printed documents into the manual paper feed.

The device is equipped with an automatic document feeder. Up to 50 Documents can be feed automatically into the machine to be scanned, faxed or copied. You can scan single documents or smaller templates using the flatbed scanner.

Your device has the image and text enhancement function Crystal with which you achieve optimal printing and copying quality for your documents.

Using the business card copy, you can copy both sides of a small document (for example of a business card) onto one page

Your device prints a weekly overview as a calendar page for you – for the current week, the coming week or a freely selectable week.

If you want, your device can print Sudoku puzzles in four different difficulty levels with solution.

In the telephone book of your device, you can save entries with multiple numbers and collect multiple entries into groups. You can assign various ring tones to the entries.

You have many functions available to you for fax transmission, for example, different resolutions or the timer function. You can secure your fax reception with a code. In that case, incoming faxes are not printed out, but rather are stored in the fax memory. With the fax polling function, you can retrieve faxes that lie ready in the dialled device.

The device prints the date and the exact arrival time on every incoming fax received. This allows you to document the exact time at which you have received a fax transmission. A memory buffer in the device ensures that the correct date and time of reception will be maintained even after a power loss.

With fax reception onto a USB storage medium, the device saves incoming faxes onto a connected USB storage medium. Fax messages are saved as TIFF files with receipt date and time.

The selection menu for USB storage media appears on the display as soon as you connect a USB storage medium (USB stick, external hard drive etc.) to the USB host port on the front of the device. You can print a list of all saved documents or individual documents as well as delete files. Save scanned documents or incoming faxes on to the USB storage medium.

You can connect the device to a computer and use it as a printer or scanner. You'll find the software on the supplied installation CD **Companion Center SFX**. In this way, you can scan and edit photos and texts, send and receive faxes and access the device's web interfaces, with which you can change many settings.

A WLAN adapter enables you to connect the device to an existing network as a network printer. All computers in the network can then access the device and scan or print.



WLAN is Optional

WLAN is optional and functions only with an original adapter, which you can purchase through our order service. More information: www.philips.com

We hope you enjoy your device and its many functions!

Table of Contents

Introduction	2	Make Copies Using User-Defined Settings	31
1 General Safety Information	5	Make Enlarged or Compressed Copies	32
2 Overview	8	Copying both Sides of a Document onto One Side (= Business Card Copy)	32
Device Overview	8	Configure Settings for Second Profile	32
Connections on the Rear Side	8	9 Telephone Functions	34
Panel with Display	9	Placing a Call on the Device	34
Overview of the Menu Functions	10	Chain Dialling	34
3 Initial Operation	12	Getting Outside Line	34
Packing Contents	12	Insert Dialling Pause	34
Removing Packaging Material	12	Calling Additional Telephone Functions	34
Connecting the Telephone Handset	14	Calling Line Identification (CLIP)	34
Connecting the Telephone Cable	14	Missed Calls	35
Connecting the Mains Cable	15	10 Telephone Book of the Device	36
Initial Installation	15	Looking up an Entry	36
Connecting to the Computer	16	Saving Entry	36
4 Companion Center SFX	17	Edit Entry	36
Requirements	17	Delete an Entry	36
Installing the Driver and Software	17	Delete all Entries	37
5 Web Interface	18	Printing the Telephone Book	37
Calling the Web Interface	18	Groups	37
Access the Web Interface with an Internet Browser	18	Exporting/Importing the Telephone Book	37
6 Scanner	19	11 Fax	39
Loading Documents	19	Send a Fax Using Standard Settings	39
Scan Document and Save to a Computer	20	Loading Documents	39
Scan Document and Save onto a USB Storage Medium	20	Dialling a Number	40
Scanning with the Companion Center SFX	21	Chain Dialling	40
7 Printer and Printing Media	23	Getting Outside Line	40
Specifications for Print Media	23	Insert Dialling Pause	41
Insert Paper into the Paper Tray	23	Sending Fax Later (= Timer Function)	41
Load Paper into the Manual Paper Feed	25	Sending Fax Manually	41
Loading Envelopes	25	Using Fax Templates	41
Inserting Slides and Labels	25	Faxing with the Companion Center SFX	41
Loading Pre-printed Material	25	Fax Reception	43
Print a List of Available Documents on USB Storage Medium	26	Receiving Fax Manually	43
Print Document from USB Storage Medium	26	Receive Faxes Silently	43
Delete Files on USB Storage Medium	27	Receiving Faxes onto USB Storage Medium	44
Print Calendar	28	Time Stamp	44
Sudoku: Printing a Game	28	Setting Protected Fax Reception	44
8 Copier	29	Polling Faxes	44
Loading Documents	29	Jobs	45
Make Copy Using Standard Settings	30	12 Networks	46
Creating Multiple Copies	30	Wireless Network (WLAN)	46
Creating Crystal Copy with Image and Text Enhancement (Crystal)	30	Setting Up a Wireless Network (WLAN)	46
Make Copies Using the Second Profile	31	Connect WLAN Adapter	47
		Switching Wireless Networking (WLAN) On/Off	47
		Setting up a Wireless Network (WLAN)	47
		Using the Wizard	47
		Setting Up a Wireless Network (WLAN) Manually	48
		Additional Wireless Network Settings	50

13 Settings	51
Set Up Power Saving Function	51
Set Up Toner Saving Function	51
Set Up Paper Saving Function	51
Selecting the Country	51
Selecting the Language	51
Setting the Date and Time	51
Entering Your Telephone Number and Name	52
Setting the Ring Tones	52
Deactivating the Button Tones	53
Configure Paper Settings	53
Set Resolution	53
Adjust contrast	53
Setting the Brightness	54
Additional Scanner Options	54
Additional Copier Options	54
Setting the Fax Reception Mode	54
Silent Fax Reception	55
Additional Options for Fax Transmission	55
Additional Fax Reception Options	55
Locking the Device	56
Print Lists and Reports	57
14 Telephone Lines and Additional Devices	58
Switching Caller Line Identification (CLIP) On/Off	58
Selecting the Dialling Process	58
Set up the Public Switch Telephone Network (PSTN)	58
Set up Private Branch Exchange (PABX)	58
DSL Connection	59
ISDN Connection	59
Registering and De-Registering Additional Cordless Telephones	59
Connecting Additional Devices	60
Using Additional Telephones (Easylink)	60
Using an External Answering Machine	60
15 Service	61
Access Help Pages	61
Display Counter Levels	61
Displaying the Toner Level	61
Checking the Firmware Version	61
Updating Firmware	62
Changing the Toner Cartridge	62
Fixing a Paper Jam	64
Cleaning	66
Calibrating the Scanner	67
Using Service Codes	67
Power Cycling	68
Problems and Possible Causes	69
Error Messages and Possible Causes	71
Glossary	74
16 Appendix	77
Technical Data	77
Guarantee	79

1 General Safety Information

Your device has been tested in conformity with standards EN 60950-1 and IEC 60950-1 and should only be operated with telephone systems and power equipment that meet these standards. The device was built exclusively for use in the indicated sales region.

Do not make any changes or settings that are not described in this user manual. Physical injury or damage to the device or loss of data can result from improper handling. Take note of all warning and safety notes indicated.

Setting Up the Device

The device should be placed securely on a stable, flat surface. If the device should fall, it can be damaged or can cause injury to people, especially small children. Position all cables in such a way that no one will stumble on them, thus avoiding possible injuries to persons or damage to the device itself. If the device is dropped it should be inspected by a technical service center.

The distance between the device and other devices or objects must be at least 15 centimetres; this also applies to the use of additional cordless telephones. Do not place the device in the vicinity of radios or televisions.

Protect the device against direct sunlight, heat, large temperature fluctuations and moisture. Do not place the device in the vicinity of heaters or air conditioners. Observe the information on temperature and humidity in the technical data.

The device must have sufficient ventilation and may not be covered. Do not put your device in closed cabinets or boxes. Do not place the machine on soft surfaces such as tablecloths or carpets and do not cover the ventilation slits. Otherwise the device could overheat or catch fire.

The area in which you operate the device must be adequately ventilated, especially if the device is used frequently. Set up your device in such a way that the flow of the exhaust air stream points away from the work station.

In the event that the device becomes too hot, or if you see smoke coming from the device, you must immediately pull the power cable out of the power socket. Have your device examined by trained professionals at a technical service location. To prevent the spread of fire, open flames should be kept away from the device.

Do not plug in the device in moist rooms. Never touch the mains cable, the mains connection or the telephone socket with wet hands.

Do not allow liquids to enter into the device. Disconnect the device from the electrical power source and from the telephone network, if liquids or foreign objects have entered the device and have your device examined by trained professionals at a technical service location.

Do not allow children to handle the device without supervision. The packing materials should be kept out of the hands of children.

Do not press forcefully on the scanner cover when you scan thicker documents or three-dimensional items, this could damage the scanner cover and/or the scanner glass.

Power Supply/Telephone Line

Check whether the mains voltage of your device (indicated on the type label) matches the mains voltage available at the setup location.

The device corresponds to EN 55022 Class B. Use only the supplied power and telephone cables. Before you use the device make sure that you connected the telephone cable supplied as described.

Never touch the power or telephone cable if the insulation is damaged. Replace damaged wires immediately. Use suitable cables only; if necessary please contact our technical customer service or your retailer.

Disconnect your device from the mains and telephone network during an electrical storm in order to avoid electrical surge damage. If this is not possible, do not use the device during an electrical storm.

Before cleaning the surface of your device, disconnect it from the power and telephone networks. Use a soft, lint-free cloth. Never use liquid, gaseous or easily flammable cleansers (sprays, abrasives, polishes, alcohol). Do not allow any moisture to reach the interior of the device.

Only clean the display with a dry, soft cloth. If the display breaks, a mildly corrosive liquid may escape. Avoid all contact with your skin and eyes.

In the event of a power failure, your device will not function; saved data is retained.

In rare cases, the saved settings can be partly or completely reset to factory defaults when the device is deactivated or in the event of a power outage. Do not deactivate the device directly after a print job or after entering settings.

Computer Connection

Use only a custom high speed certified USB cable to connect the device to your computer. The cable should be no longer than 1.5 metres.

Wireless Network (WLAN)

The functioning of security systems, medical equipment or sensitive devices can be disrupted by the transmission power of the device. Observe any usage regulations (or restrictions) in the vicinity of such equipment.

The use of this device can affect the operation of insufficiently shielded medical devices and hearing aids and pacemakers through the release of high frequency radiation. Also consult a doctor or the manufacturer of the medical device to establish whether these are sufficiently shielded from external high frequency radiation.

USB Storage Media

Only use storage media that are compatible with the device. Ensure that the power of a USB device does not exceed the permitted amp limit of the USB connection. You can only connect **one** high power device (USB 2.0) to each USB connection. Do not connect additional devices—such as batteries, fans, charging devices—to your machine. The device only recognises storage media which are formatted with **FAT16** or **FAT32**. **NTFS** is not supported.

Never pull out the storage medium while the device is accessing it. This could cause data to be damaged or lost.

When carrying out a Firmware update only use the Firmware file for your device from the website: www.philips.com. Using other Firmware files can lead to your device not functioning properly. Sagemcom accepts no liability for device malfunctions which can be traced back to the use of third party Firmware.

The firmware running on the device is partly licensed under GPL. If you have any questions about the licensing of a specific part of the firmware, feel free to contact us on the e-mail address: support.service@sagemcom.com. We can send you a CD containing the relevant source code for the cost of production.

Consumable Materials

Use only original consumable materials. These are available from a specialised retailer or through our order service (see back side of this user manual). Other consumable materials could damage the device or shorten its service life.

Dispose of old consumable materials according to the waste regulations of your country.

Caution when Handling Toner Powder:

If you breathe in toner powder, go into the fresh air immediately. Call a doctor immediately!

If you have swallowed toner powder, drink small amounts of water. Try **NOT** to vomit. Call a doctor immediately!

If you get toner powder in your eyes, rinse them with a lot of water for at least 15 minutes. Call a doctor immediately!

Never open a toner cartridge. Store both new and used cartridges in a place where they will not come into the hands of children.

In case of a paper jam, remove the paper carefully out of the device. Throw the paper away carefully; it is possible that the toner may not be completely set on the print-out, and toner dust could be released into the air.

If toner dust is released into the air, you should avoid allowing it to contact your skin and eyes. Do not inhale the released toner dust. Remove the toner dust from clothing or objects with cold water; hot water would only cause the toner to set. Never remove loose toner dust with a vacuum cleaner.

Repairs

The fuser unit and its surroundings inside the device become hot during operation. Do not touch these parts if you have opened the device. Proceed with care when you are removing a paper jam for instance.

Should disruptions occur, follow the instructions on the display and on the error report.

Do not make any repairs to the device yourself. Improper maintenance can result in injuries or damage to the device. Only have your device repaired by an authorised service centre.

Do not remove the type label from your device; this would void the warranty.

Laser Safety

With specific reference to lasers, the equipment complies with laser product performance standards set by governmental, national, and international agencies as a Class 1 Laser Product. The device is designed in such a way that the user is not exposed to any laser radiation that exceeds the values for Class 1 under normal operating conditions and with proper maintenance and use.

Direct (or indirect reflected) eye contact with the laser beam might cause serious eye damage. Safety precautions and interlock mechanisms have been designed to prevent any possible laser beam exposure to the operator. Only a qualified service technician should open the device and carry out service operations.

 **Class 1 Laser Product**

About this User Manual

With the installation guide on the following pages, you can start using your device quickly and easily. Detailed descriptions can be found in the following sections of this user manual.

Read the entire user manual carefully. Follow all safety instructions in order to ensure proper operation of your device. The manufacturer accepts no liability if these instructions are not followed.

Symbols Used



Troubleshooting

This symbol designates tips that will help you to use your device more effectively and easily.

CAUTION!



Damage to the Device or Loss of Data!

This symbol gives warning of damage to the device and possible loss of data. These damages can result from improper handling.

DANGER!



Danger to Persons!

This symbol gives warning of danger to persons. Physical injury or damage can result from improper handling.

DANGER—LASER!



Radiation Hazard!

This symbol in the user manual or inside the device indicates a danger of visible and invisible radiation. Eye injuries or other damage can result from improper handling.

DANGER—HEAT!



Heat risk!

This symbol in the user manual or inside the device indicates a danger of hot surfaces. Physical injury or damage can result from improper handling.

2 Overview

EN

Device Overview

- ① Scanner cover
- ② Panel with display
- ③ Printout and Fax Outlet
- ④ Printer output tray
- ⑤ Paper tray
- ⑥ Manual paper feed
- ⑦ socket—USB Host connection for storage medium
- ⑧ Telephone handset with spiral cable

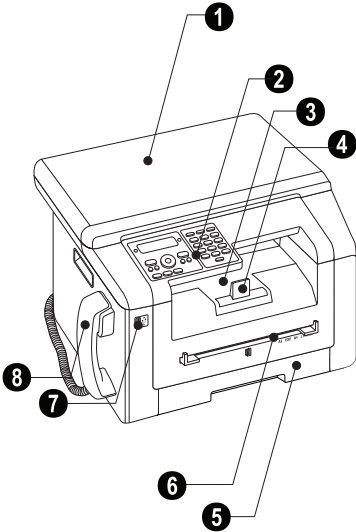

- ① Scanner glass
- ② Toner cartridge
- ③ Paper jam door (print unit)

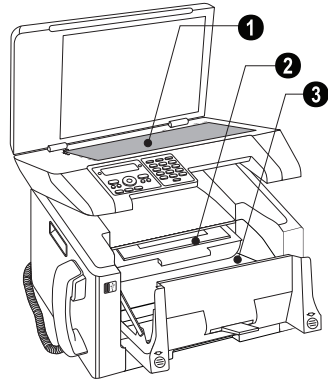

Connections on the Rear Side

- ① FAX/☎ socket—Connection socket for telephone cable
- ② AUX./☎ socket—Connection socket for additional devices
- ③) socket—Connection socket for the telephone handset
- ④ Tension lever of the fixer unit (**Two levers!**)
- ⑤ ↔ socket—USB Host connection for storage medium
- ⑥ ↔ socket—USB connection for the computer
- ⑦ Paper jam door (fuser unit)
- ⑧ Mains cable socket
- ⑨ On/Off switch

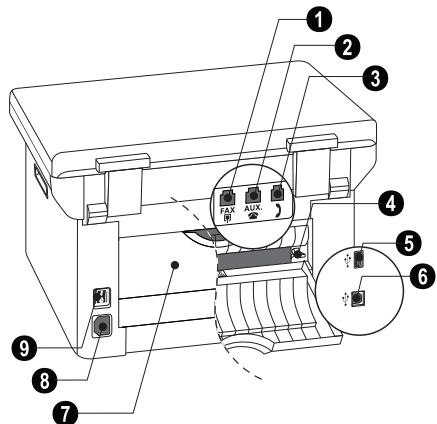

Panel with Display

Red lamp —If the lamp flashes or is lit, please read what is indicated on the display

Green Lamp —The green lamp on the panel will flash whenever there is a fax present in the memory.

—Function abort / return to the starting mode

C—Calling the menu functions / Returning to the previous menu level / deleting individual digits

—Setting number of copies / navigation within the menu / selecting options / moving the cursor

OK—Press twice: making copies automatically. Press once: adjusting copies / Menu Navigation: confirming input

—Starting transmission of message / starting action

—Set the contrast for the scanner

/**ZOOM**—Set the zoom parameter (reduced or enlarged scans)

/**DUPLEX**—Select double-sided or one-sided printing (Duplex/Simplex)

—Setting higher resolution for faxes (DEFAULT, FINE, SFINE, PHOTO) and copying (AUTO, TEXT, QUALITY, PHOTO)

FAX—Start a fax transmission or fax reception

COPY—Press twice: making copies automatically. Press once: adjusting copies

SCAN—Open selection menu for scanning functions

—Redial / caller list: The redial / caller list contains the last numbers dialled and the last calls received (* indicates the numbers dialled, † the calls received and * the calls missed).

R—Insert short line interruption (Hook Flash) as office index on PABX or for calling special functions in the public telephone network (PSTN)

—Calls up telephone book functions

Numeric keypad—Inputting digits, characters and special characters

ECO—Retrieves the paper, power and toner saving / make a copy using the toner saving function

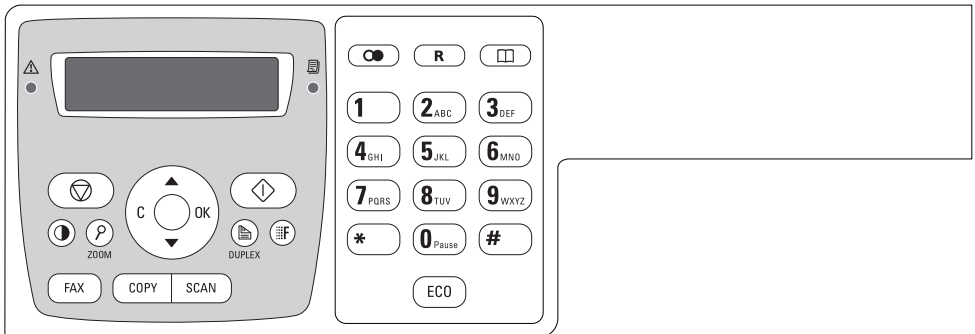

Overview of the Menu Functions

The following functions are available on your device. There are ways in which you can call functions.

Navigating in the Menu: Press **C** to access the function menu. Page through **▲/▼** menu entries. Use **OK** to select a menu function. Press **C** to return to the previous menu level. Press **⏻** to close the menu and return to the starting mode.

Calling Functions Directly: You can call a menu function directly using the function number. Press **C** and enter the appropriate function number using the numeric keypad. Confirm with **OK**. You will find the function number in the following list.

0 Settings

0 0 2 Setting the Paper, Power and Toner Saving Functions. ...	page 51
0 0 7 Deactivating the Button Tones ...	page 53
0 1 Setting the Date and Time ...	page 51
0 2 1 Entering Name ...	page 52
0 2 2 Entering Number ...	page 52
0 3 1 Setting the Country ...	page 51
0 3 2 Set the telephone network* ...	page 58
0 3 3 Setting the Language ...	page 51
0 4 1 Setting the Fax Reception Mode ...	page 54
0 4 2 Setting the Number of Ring Tones for Fax Reception ...	page 53
0 5 1 Switch PABX Operation On/Off ...	page 58
0 5 2 2 Enter a dialling code for the PABX operation ...	page 59
0 5 3 Set the dialling mode (tone/pulse dialling)* ...	page 58
0 5 4 Selecting the Ring Tone ...	page 52
0 5 5 Setting the Ring Volume ...	page 52
0 5 7 Switching Caller Line Identification (CLIP) On/Off ...	page 58

*Function is not supported in all countries and networks

1 Copier

1 0 Set the copier settings ...	page 53
1 1 Make Copy Using Standard Settings ...	page 30
1 2 Make Copies Using the Second Profile ...	page 31
1 3 Make Enlarged or Compressed Copies ...	page 32

1 5 Creating Crystal Copy with Image and Text Enhancement (Crystal) ...	page 30
1 6 Copying both Sides of a Document onto One Side (= Business Card Copy) ...	page 32

2 Printer

2 0 Configure Paper Settings ...	page 53
2 1 1 Print a List of Available Documents on USB Storage Medium ...	page 26
2 1 2 Print Document from USB Storage Medium ...	page 26

3 Scanner

3 1 Scan Document and Save to a Computer ...	page 20
3 2 Scan Document and Save onto a USB Storage Medium ...	page 20
3 0 Configure Scanner Settings ...	page 54

4 Fax

4 0 1 Set Fax Transmission ...	page 55
4 0 2 Set Fax Reception ...	page 55
4 0 3 Setting Protected Fax Reception ...	page 44
4 0 4 Switches Time Stamp On/Off ...	page 55
4 1 Sending a Fax ...	page 39
4 2 Poll Faxes ...	page 44
4 4 Receiving Faxes onto USB Storage Medium ...	page 44
4 5 Printing the Fax Templates ...	page 41

5 Telephone Book

5 1 1 Looking up an Entry ...	page 36
5 1 2 Saving Entry ...	page 36
5 1 3 Creating Group ...	page 37
5 1 4 Edit Entry ...	page 36
5 1 5 Deleting an Entry ...	page 36
5 1 6 Printing the Telephone Book ...	page 57
5 1 7 Load Telephone Book from USB Storage Medium ...	page 38
5 1 8 Saving Telephone Book onto USB Storage Medium ...	page 38

5 Cordless Telephone

5 2 1 Registering cordless telephone* ...	page 59
5 2 2 De-registering cordless telephone* ...	page 60
5 2 3 Locating cordless phones* ...	page 60

*Function is optional and functions only with an original adapter, which you can purchase through our order service. More information: support.service@sagem-com.com

7 Jobs

- 7 1** Immediate Job Execution ... page 45
- 7 2** Changing a Job ... page 45
- 7 3** Deleting a Job ... page 45
- 7 4** Printing a Job ... page 45
- 7 5** Printing the Job List ... page 57

- 0 8 4** Set Static IP Address Assignment ... page 49
- 0 8 5** Verify DHCP Settings ... page 49
- 0 8 6** Additional Wireless Network Settings ... page 50

8 Lists and Reports

- 8 0** Printing List of Settings ... page 57
- 8 1** Printing the List of Available Functions ... page 57
- 8 2** Printing Fax Journal ... page 57
- 8 3** Printing the Telephone Book ... page 57
- 8 4** Printing the Job List ... page 57
- 8 5** Print Calendar ... page 28
- 8 6** Sudoku: Printing a Game ... page 28
- 8 7** Printing the Fax Templates ... page 41

9 USB Storage Medium

- 9 1 1** Print a List of Available Documents on USB Storage Medium ... page 26
- 9 1 2** Print Document from USB Storage Medium ... page 26
- 9 1 3** Scan Document and Save onto a USB Storage Medium ... page 20
- 9 1 4** Receiving Faxes onto USB Storage Medium ... page 44
- 9 1 5** Delete Files on USB Storage Medium ... page 27

9 Miscellaneous

- 9 2** Locking the Device ... page 56
- 9 3 1** Calibrating the Scanner ... page 67
- 9 3 3** Using Service Codes ... page 67
- 9 3 4** Checking the Firmware Version ... page 61
- 9 4** Query the counter levels ... page 61
- 9 4 6** Displaying the Toner Level ... page 61

08 Wireless Network (WLAN)



WLAN is Optional

WLAN is optional and functions only with an original adapter, which you can purchase through our order service. More information: www.philips.com

- 0 8 0** Switching Wireless Network (WLAN) On/Off ... page 47
- 0 8 1** Setting up a Wireless Network (WLAN) Using the Wizard ... page 47
- 0 8 2** Setting Up a Wireless Network (WLAN) Manually ... page 48
- 0 8 3** Set IP Address Assignment ... page 49

3 Initial Operation

EN

Packing Contents

- 1 Device
- 2 Starter cartridge (already installed)
- 3 Mains cable with plug (country-specific)
- 4 Telephone cable with plug (country-specific)
- 5 Paper tray (already installed)
- 6 Spiral cable for telephone handset
- 7 Telephone handset

Installation-CD (not depicted)

User manual with installation guide (not depicted)

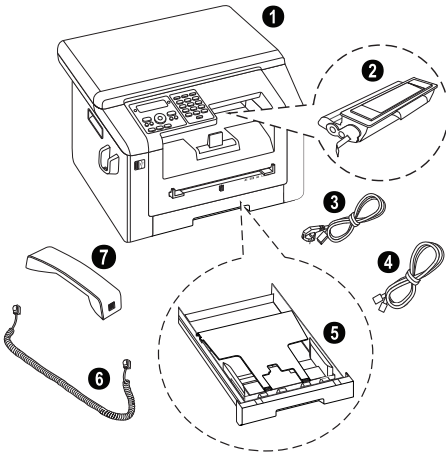

Missing Package Contents

If any of the parts are missing or damaged, please contact your retailer or our customer service.

Removing Packaging Material

Removing Packaging Material from the Device

Remove the existing tape used for transportation from the device.

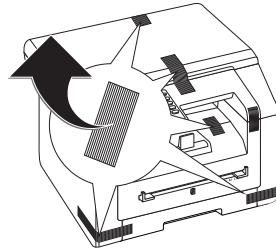

Remove the Packaging Material from the Toner Cartridge

1. Open the upper device cover by gripping the cover on the arrow marks on the outside and lift upwards,

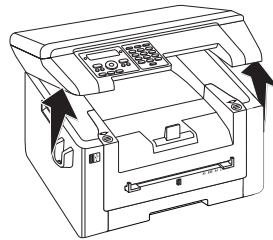

2. Open the device by lifting the device cover forwards

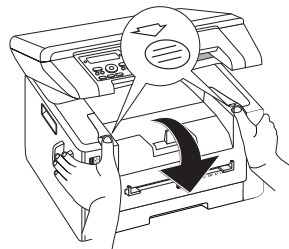

3. Remove the toner cartridge by gripping the handle in the middle and pulling it forwards out of the device

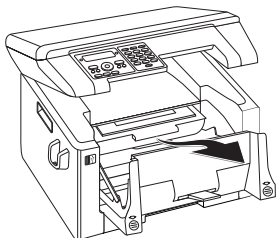

4. Remove the tape and protective paper, but do not remove the protective strip from the cartridge yet.

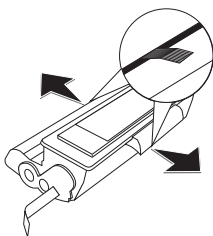

DANGER!



Escaping Toner Dust!

Never open a toner cartridge. If toner dust is released into the air, you should avoid allowing it to contact your skin and eyes. Do not inhale the released toner dust. Remove the toner dust from clothing or objects with cold water; hot water would only cause the toner to set. Never remove loose toner dust with a vacuum cleaner.

5. Shake the new toner cartridge back and forth several times in order to distribute the toner evenly, thereby improving the print quality.

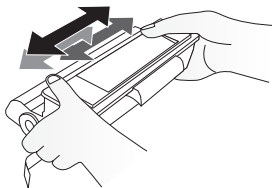

6. Only after completely pull off the protection strip located on the left side of the cartridge.

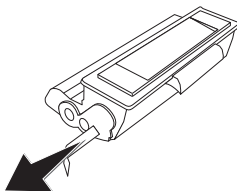

DANGER!



Escaping Toner Dust!

Once you have removed the protection strip, do not shake the toner cartridge any more. Otherwise, it is possible that toner dust will be released into the air.

7. Place the toner cartridge into your device. The cartridge should snap securely into position.

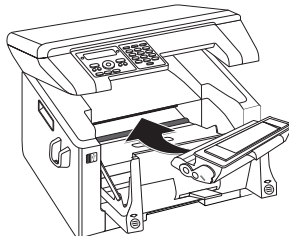

8. Close the device.

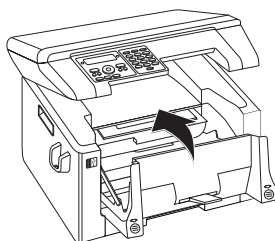

CAUTION!



Toner Cartridge Not Inserted Correctly!

If the device cover would not close, the toner cartridge is not inserted correctly. Take the toner cartridge out and insert it again correctly.

9. Close the upper device cover.

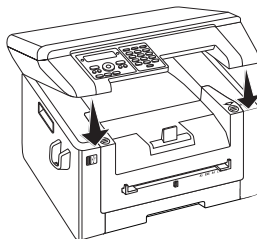

Remove the Packaging Material from the Paper Tray

1. Pull the paper tray out of the device.

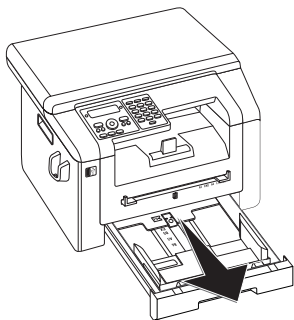

2. Lift up the cover of the paper tray

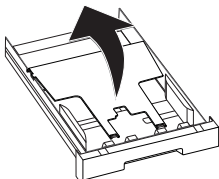

3. Please remove the protective cardboard from the paper tray before loading paper.

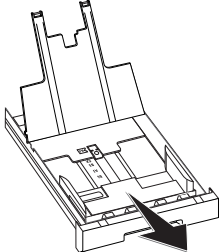

4. Removing the tape in the paper tray which was used for transportation purposes.



Loading Paper

Adjust the paper tray to the paper and insert the paper (see also chapter *Printer and Printing Media*, page 23).

5. Close the paper tray cover.

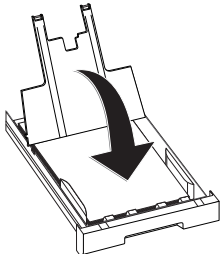

Cover of the Paper Tray

If the cover of the paper tray has become detached, fasten the lid into the supports. Ensure that the flat side of the cover (with the inscription) faces upwards.

6. Push the paper tray into the device all the way to the stopping point.

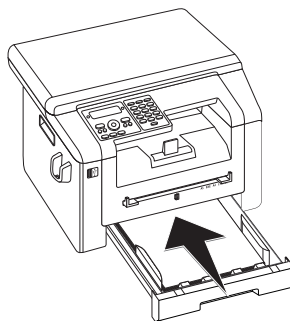

Connecting the Telephone Handset

Plug one end of the spiral cable into the socket on the telephone handset. Insert the other end into the socket designated with the  symbol.

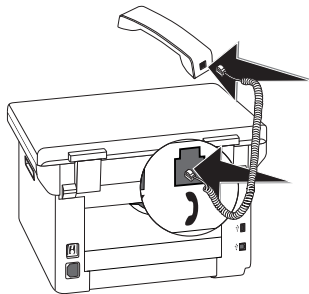

Connecting the Telephone Cable

Connect the telephone cable to the device by inserting it in the socket designated with **FAX**/ (RJ-11-Connector). Insert the telephone plug into your PTT line socket.

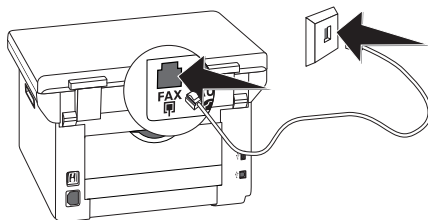

CAUTION!**Connection to an ISDN system!**

You can not connect your devices directly to the digital output of the ISDN system. Details for ISDN connections can be found in the instructions provided with the terminal adapter or the dial-up router.

**Connection to Private Automatic Branch Exchange**

If you connect your device as extension to a telephone system, you must set it for working as an extension (see also chapter *Telephone Lines and Additional Devices*, page 58).

Connecting the Mains Cable

CAUTION!**Mains Voltage at the Site of Installation!**

Check whether the mains voltage of your device (indicated on the type label) matches the mains voltage available at the setup location.

1. Insert the mains cable into the connection located on the rear side of the device. Plug the power cable into the electrical outlet.

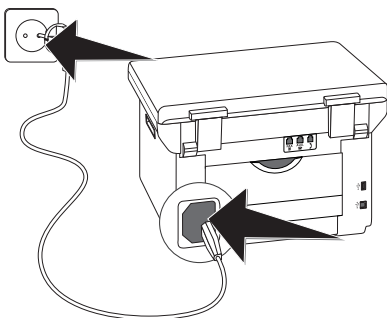

2. Switch the device on using the on/off switch on the rear.

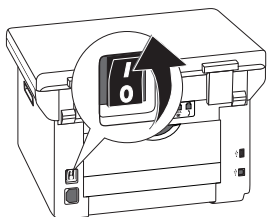

Initial Installation

After you connect your device to the mains voltage, the device starts. During the booting process, the lights flash. Wait until the initial installation process begins.

Selecting the Language

1. Use ▲/▼ to select the desired display language.
2. Confirm with **OK**.

Selecting the Country

CAUTION!**Setting the Country Correctly!**

You must set the country in which you are operating the device. Otherwise your device is not adapted to the telephone network. If your country is not included in the list, you must select a different setting and use the correct telephone cable for the country. Consult your retailer.

1. Use ▲/▼ to select the country in which you are operating the device.
2. Confirm with **OK**.

Set the Time Zone

(Function is not supported in all countries and networks)

In countries with several time zones, you can select from preset time zones or enter the deviance of your time zone from UTC (see also chapter *Set the Time Zone*, page 52). In countries with one time zone, the setting is adjusted automatically if you set the country correctly.

1. Use ▲/▼ to select the time zone in which you are operating the device.
2. Confirm with **OK**.

**Automatic Changeover Between Summer Time/Winter Time**

With setting the country and time zone, the automatic changeover between summer and winter time is switched on. The automatic changeover is switched off if you enter the deviance from UTC manually using the time zones editor

Entering Name

Your name and number are added together with date, time and page number at the top edge of each fax transmission (= header).

1. Enter your name. You can enter characters using the numeric keys (see key labels). Enter special characters using **[0]**. Press the respective key several times until the desired character or special character appears on the display.



Navigating in the Editor

You can move the cursor using **▲/▼**. Use **C** to delete individual characters.

2. Confirm with **OK**.

Entering Number

1. Enter your number.
2. Confirm with **OK**.

Entering the Date and Time

1. Enter the date (two digits for each field), for example **[3][1][0][5][2][5]** for May 31th, 2025.
2. Enter the time, e.g. **[1][4][0][0]** for 2 pm.
3. Confirm with **OK**.

Connecting to the Computer

Using the USB cable, you can connect your device to a PC that is connected to a network. Other PCs on this network can then access the device if it is shared for use on the network. You cannot connect the device directly to a network with a USB cable, unless you have a USB print server connection.

You can connect the device to a computer and use it as a printer or scanner. You'll find the software on the supplied installation CD **Companion Center SFX**. In this way, you can scan and edit photos and texts, send and receive faxes and access the device's web interfaces, with which you can change many settings.



Network Connection

You can find information about installing your device in a network in chapter *Networks* (see also chapter *Networks*, page 46).

Requirements

Your computer must have one of the following operating systems.

Microsoft Windows

2000 (SP4) · XP · Vista · Windows 7
Windows Server 2003/2008

Apple Macintosh

OS 10.4 · 10.5 · 10.6

Linux

Redhat 9.0 · Debian 5.0 · Suse 11.1 · Fedora 11
Ubuntu 9.10

Connecting USB Cable

1. Close all open programs and applications before beginning the installation process. Place the installation CD in the CD-ROM drive of your computer. The program will start automatically.

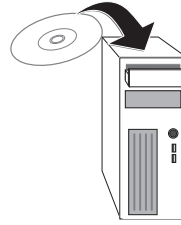

2. Connect the device to your PC with a typical USB cable. The USB port of your device can be found on the rear side.



Recommended Interface Cables

Recommended interface cables are: for the USB connection a High-Speed 2.0 certified USB cable which must not exceed 2.0 metres in length.

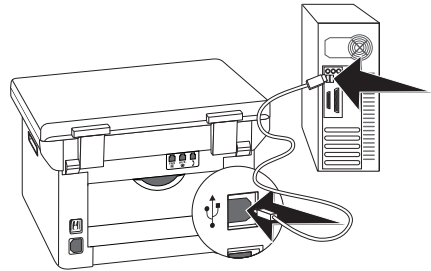

4 Companion Center SFX

You can connect the device to a computer and use it as a printer or scanner. You'll find the software on the supplied installation CD **Companion Center SFX**. In this way, you can scan and edit photos and texts, send and receive faxes and access the device's web interfaces, with which you can change many settings.



Network Connection

You can find information about installing your device in a network in chapter *Networks* (see also chapter *Networks*, page 46).

Requirements

Your computer must have one of the following operating systems.

Microsoft Windows

2000 (SP4) · XP · Vista · Windows 7
Windows Server 2003/2008

Apple Macintosh

OS 10.4 · 10.5 · 10.6

Linux

Redhat 9.0 · Debian 5.0 · Suse 11.1 · Fedora 11
Ubuntu 9.10



Informations for the Technical Customer Services

Should problems with the computer connection arise, have the following information to hand when you contact technical customer services: hardware configuration of your computer, operating system installed and security programmes used (anti-virus programmes, firewall). Then we can help you more quickly.

Installing the Driver and Software

CAUTION!



Installing the Software first!

First install the software. The device may not be connected to the PC before this. After the software installation, the PC must be restarted. **Only then** should you connect your PC and the device with a USB cable.

1. Close all open programs and applications before beginning the installation process. Place the installation CD in the CD-ROM drive of your computer. The program will start automatically.



Starting Program Manually

If the program does not start automatically, select the CD-ROM drive in the Windows Explorer and start the program **Setup.exe** with a double-click.

2. The **Companion Center SFX** window appears on the screen. Click on **Install All** to install the software and all drivers.

Click on **Browse contents** to view the files on the installation CD. Click on **View user guides** to access the device's instruction manual.



3. Next you will be asked to accept the licensing conditions. Click on **Yes**.
4. The software and drivers are installed. This Process May Take a Few Moments.
5. At the conclusion of the install process you must restart your computer. Make your selection as to whether the computer should restart automatically or whether you would like to restart the computer yourself at a later time.
6. **Only after** the restart, connect the device to your PC with a typical USB cable. The USB port of your device can be found on the rear side.



Recommended Interface Cables

Recommended interface cables are: for the USB connection a High-Speed 2.0 certified USB cable which must not exceed 2.0 metres in length.

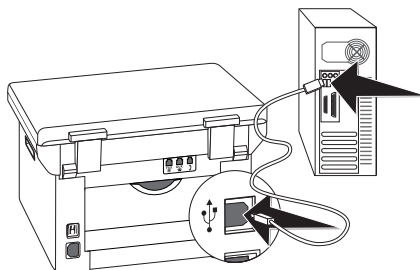

7. Your device is detected as a new peripheral device and registered.
8. If your operating system is Windows XP, an additional window will appear during the final installation. Select **No, not this time**, and click on **Next**.
9. Under Windows XP, select **Install software automatically** during the final installation and click on **Next**.

5 Web Interface

EN

The web interface is available to you on all operating systems. You can access the web interface with the software **Companion Center SFX** or with an internet browser on your computer. The web interface shows you the current status of the device and all settings. You can edit the device settings and the telephone book.

You can access the internet interface if you have connected the device directly with a computer via the **USB** port or if the device is connected to a network.

Calling the Web Interface

1. Start the software **Companion Center SFX**, by clicking on the **Companion Center SFX** icon on your desktop or selecting **Start > Programs > Companion Center SFX > Laser SFX > Companion Center SFX** in the Start Menu.
2. The light in the upper-right corner shows whether or not the device is connected to the computer and is functioning properly.
3. Selecting the **Settings** tab.

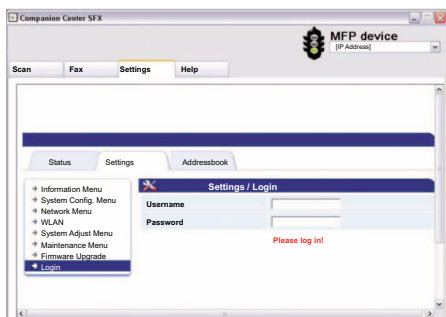

4. The internet interface's settings pages are protected with a password. Enter the login data:
Name: **user**
Password: **user**
5. Click on **Login**.

CAUTION!



Changing Password and Noting!

Change the password when you call the web interface for the first time, so that there is no unauthorised access to your device. Note down your password in a safe place. Should you forget your password, you must reset your device to factory settings, in order to be able to access it again. All personal settings will be deleted.

Access the Web Interface with an Internet Browser

You need the current IP address of the device in order to access the web interface with an internet browser. You will find the IP address on the settings list.



Prints the List of Settings

Press **C**, **8** **0** and **OK** to print a list of all settings of your device.

1. Start an Internet browser on a computer, which is connected to the network.



Suitable Internet Browser

We recommend the following Internet browser. Windows PC: Internet Explorer (Version 6.0 or above), Apple Macintosh: Safari (version 1.3 or above), Linux: Conquerer (version 3.2.1 or above).

2. Enter the IP address of the device in the address bar of the browser.
3. Confirm using **Return**.

6 Scanner

You can scan a document and save it onto a USB storage medium or on a network computer.

You'll find the software on the supplied installation CD **Companion Center SFX**. In this way, you can scan documents from your computer, send faxes, and manage the device settings via the web interface (see also chapter *Installing the Driver and Software*, page 17).

Specifications for Documents	
Width of Documents	208–218 mm
Length of Documents	277–600 mm
Paper Weight of the Documents	60–90 g/m ²
Capacity	50 page (60–90 g/m ²)
Manufacturer's Recommendation for Optimum Operation	A4 · A5 · Letter · Legal (80 g/m ²)

CAUTION!



Unsuitable Documents!

Do not insert any documents into the device that ...

... are wet, have been edited with correction fluid, are soiled or have a coated surface.

... that are written on with a soft pencil, with paint, chalk or charcoal.

... originate from newspapers or magazines (printing ink).

... that are held together with office or notebook staples or with tape or glue.

... are pasted with note papers.

... are creased, crumpled or torn.

Loading Documents

1. Open the scanner cover.

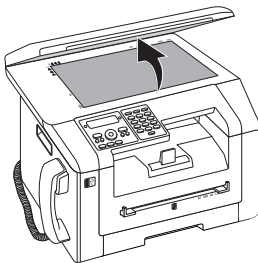

2. Lay the document onto the scanner glass with the written side down.

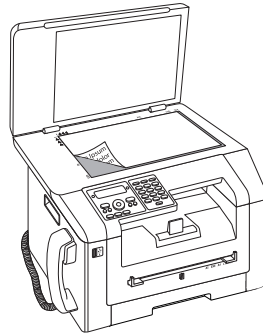

3. Align the document with the rear left corner of the scanner glass (arrow marks). The markings on the scanner border for the A4 and A5 formats will help you to position the document correctly.

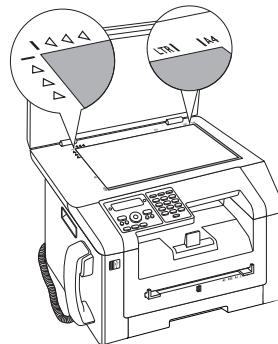

Enlarge Detail

If you would like to copy a detail (such as a graphic) of your document, position the document so that the detail view is close to the source. Using the zoom function, you can separate the desired area from rest of the document.

4. Close the scanner cover.

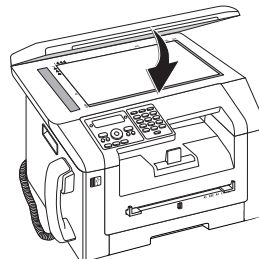



Adjust Scanner Cover

The scanner cover is equipped with adjustable hinges, allowing you to lay even thicker documents (e.g. books) in the flatbed scanner. Carefully lift the scanner cover so that it rests as evenly as possible.

Use clear sheets of plastic when copying three-dimensional objects (e.g. coins, flowers) to avoid damaging the scanner glass.

CAUTION!



Do Not Press on the Scanner Cover!

Do not press forcefully on the scanner cover when you scan thicker documents or three-dimensional items, this could damage the scanner cover and/or the scanner glass.

Scan Document and Save to a Computer

Using this function, scan a document with your device and transfer it onto a computer which is connected directly to the device using a USB cable.



Start Scanning from Computer

Using the *Companion Center SFX* software, you can call up the scan on the computer. You can also start the scanning process from any other graphics program if it is supported by the Twain Driver. Select the Twain Scanner Driver as your scanner.

Make Scans Using Standard Settings

1. Press **SCAN**.
2. Select with $\blacktriangle/\blacktriangledown$ **SCAN** → **PC USB**.
3. Confirm with **OK**.



Access Function

You can also call the function by pressing **C**, **3** **1** and **OK**.

4. Press **OK**.

Make Scans Using User-defined Settings

1. Press **SCAN**.
2. Select with $\blacktriangle/\blacktriangledown$ **SCAN** → **PC USB**.
3. Confirm with **OK**.
4. Select with $\blacktriangle/\blacktriangledown$ **SETTINGS**.
5. Confirm with **OK**.



Access Function

You can also call the function by pressing **C**, **3** **1** and **OK**.

6. Using $\blacktriangle/\blacktriangledown$, select whether you want to scan the document in greyscale or in colour.
7. Confirm with **OK**.

8. Enter a name for the file.

You can enter characters using the numeric keys (see key labels). Enter special characters using **0**. Press the respective key several times until the desired character or special character appears on the display.



Navigating in the Editor

You can move the cursor using $\blacktriangle/\blacktriangledown$. Use **C** to delete individual characters.

9. Confirm with **OK**.

10. Using $\blacktriangle/\blacktriangledown$, select whether you would like to save the file as an image file or as a PDF file.



Select the File Format

For an image file, you can select whether you would like to save the file in TIFF or JPEG format (see also chapter *Select the File Format*, page 54).

11. Confirm with **OK**.

12. Select the desired resolution using F :

DRAFT (100)—Scanning with reduced resolution—for use on the Internet, for example

TEXT B&W (300)—Black and white scan with high resolution for optical character recognition of text documents (OCR)

PHOTO (200)—Scanning with higher resolution - for photographs, for example

HQ (300)—Scanning with highest resolution

13. Press \diamond . The document is scanned and transferred to the computer.

14. If you want to scan a multiple page document with the flatbed scanner, insert another page and select **NEXT PAGE** with $\blacktriangle/\blacktriangledown$.

15. Confirm with **OK**.

Scan Document and Save onto a USB Storage Medium

CAUTION!



Compatible USB Storage Media!

Ensure that the power of a USB device does not exceed the permitted amp limit of the USB connection. You can only connect **one** high power device (USB 2.0) to each USB connection. Do not connect additional devices—such as batteries, fans, charging devices—to your machine. The device only recognises storage media which are formatted with **FAT16** or **FAT32**. **NTFS** is not supported.



Analysing USB Storage Medium

If a lot of documents are saved on the USB storage medium, it can take a while for the USB storage medium to be analysed. You can interrupt the process at any time, by pressing O .

You can scan documents with your device and save them as JPG-, PDF-, or TIFF-files on a connected USB storage medium.



Folder Destination

The files will be stored in the folder \backslash **[device name]** \backslash **Scan** on the USB storage medium. If this folder does not exist, then it will be created.

1. Insert the document.
2. Make sure that a USB storage medium is connected to the USB host port on the front or on the back-side of the device. Connect a USB storage medium as required.

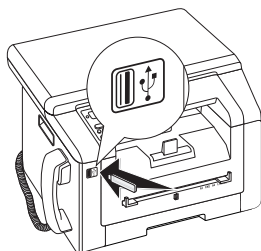

Selection Menu for USB Storage Media

The selection menu for USB storage media appears on the display as soon as you connect a USB storage medium (USB stick, external hard drive etc.) to the USB host port on the front of the device.

3. Using Δ/∇ **SCAN** \rightarrow **USBKEY** from the menu or press **C**, **9** **1** **3** and **OK**.



Access Function

You can also call the function by pressing **C**, **3** **2** and **OK**.

4. Using Δ/∇ , select whether you want to scan the document in greyscale or in colour.
5. Confirm with **OK**.
6. Enter a name for the file.

You can enter characters using the numeric keys (see key labels). Enter special characters using **0**. Press the respective key several times until the desired character or special character appears on the display.



Navigating in the Editor

You can move the cursor using Δ/∇ . Use **C** to delete individual characters.

7. Confirm with **OK**.
8. Using Δ/∇ , select whether you would like to save the file as an image file or as a PDF file.



Select the File Format

For an image file, you can select whether you would like to save the file in TIFF or JPEG format (see also chapter *Select the File Format*, page 54).

9. Confirm with **OK**.

10. Select the desired resolution using Δ/∇ :
DRAFT(100)—Scanning with reduced resolution—for use on the Internet, for example
TEXT B&W (300)—Black and white scan with high resolution for optical character recognition of text documents (OCR)
PHOTO(200)—Scanning with higher resolution - for photographs, for example
HQ(300)—Scanning with highest resolution
11. Confirm with **OK**.
12. Set the desired contrast using Δ/∇ .
-/1—Reduces the contrast / typeface appears lighter
4 (Factory settings)—Optimized adaptation for all documents
+/7—Increases the contrast / typeface appears darker (for example, documents with faint print)
13. Confirm with **OK**.
14. Using Δ/∇ , select the desired level of brightness:
-/1—Reproduction is lighter
4 (Factory settings)—Optimized adaptation for all documents
+/7—Reproduction is darker
15. Confirm with **OK**. The document is scanned and saved on the USB storage medium.
16. If you want to scan a multiple page document with the flatbed scanner, insert another page and select **NEXT PAGE** with Δ/∇ .

CAUTION!



Removing USB Storage Media!

Never pull out the storage medium while the device is accessing it. This could cause data to be damaged or lost.

Scanning with the Companion Center SFX

With the **Companion Center SFX** software, you can scan documents and then edit them on the computer.

1. Start the software **Companion Center SFX**, by clicking on the **Companion Center SFX** icon on your desktop or selecting **Start > Programs > Companion Center SFX > Laser SFX > Companion Center SFX** in the Start Menu.
2. The light in the upper-right corner shows whether or not the device is connected to the computer and is functioning properly.

3. Selecting the **Scan** tab.

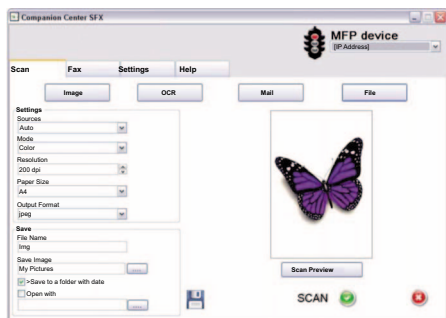

4. Select from the default settings for various usage profiles.

Image—Optimized settings for scanning photos.

OCR—(Optical character recognition) Reading printed text and importing it as a text document which can be edited and modified. Photos or handwritten texts are excluded from character recognition.

Mail—The scan is attached to an e-mail.

File—The scan is saved as a file.

5. If you would like to change the current settings, the following functions are available:

Sources—Automatic document feeder or flat-bed scanner as scan source

Mode—Scan in the black-and-white mode (also called “barcode mode”) or in the grey tone mode.

Resolution—Select the scan resolution

Paper Size—Setting the paper format

Output Format—Select the file format

6. In **File Name**, enter the name of the output file.

7. Under **Save Image**, select the folder where the file is to be saved. With the option **>Save to a folder with date**, the file is saved in a folder with the current date.

8. Activate the function **Open with** if you want to open the scanned file after the scanning process is complete. Select the desired program. For example, you can open an image file in an image-editing program, an OCR in a word-processing program, or an email attachment in your email program.

9. Click on **Scan Preview** to see a preview of the scanned document.

10. Click on the button **Scan** in order to start the scanning process.

7 Printer and Printing Media



Printing from Computer

When you install the **Companion Center SFX** on your computer, the device is also installed as a printer under Windows. In the print menu under **Start > Setting > Printers**, you will find your device listed as **Laser Printer Scanner**.

You can access your device from any program and use it to make black-and-white print-outs just as you would use any other printer. Simply select the **Laser Printer Scanner** as your printer.

Specifications for Print Media

You can insert normal printing paper or printed documents (forms) into the paper tray. You can insert special paper formats, envelopes, slides, sheets of labels or printed documents into the manual paper feed.

Paper Tray	
Paper Sizes	Size A4 · A5 · B5 (JIS) · Letter · Legal (13/14") · Exec
Weight	60–105 g/m ²
Capacity	250 sheets

Manual Paper Feed	
Paper Sizes	Width: 98–216 mm Length: 148–356 mm
Weight	60–165 g/m ²
Capacity	1 sheets

CAUTION!



Unsuitable Paper!

Do not insert any sheets of paper into the paper tray ...

... are wet, have been edited with correction fluid, are soiled or have a coated surface.

... that are held together with office or notebook staples or with tape or glue. Use sheets of labels for use in laser printers.

... are pasted with note papers.

... are creased, crumpled or torn.

CAUTION!



Forms from a Laser Printer!

Forms that have been printed out by a laser printer are not suitable for further printing.

Insert Paper into the Paper Tray

1. Pull the paper tray out of the device.

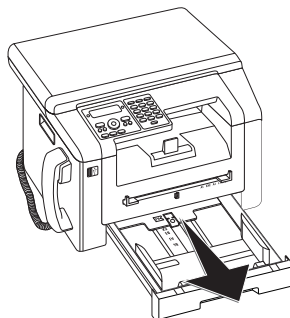

2. Lift up the cover of the paper tray

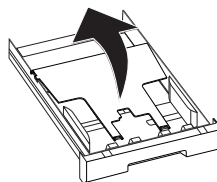

CAUTION!



Initial Operation!

Please remove the protective cardboard from the paper tray before loading paper and replacing the paper tray into the device.

3. Adjust the length of the paper tray to the printer paper. Press the lock key on the base of the paper tray. Slide the rear panel until it snaps into the suitable marking: Legal = **LG**, A4 = **A4**, A5 = **A5**, Letter = **LE**, B5 = **B5**.

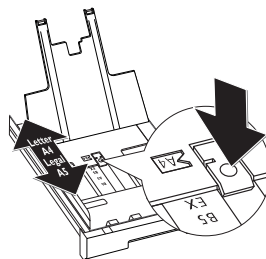

- 4. Separate the paper sheets by fanning them out, then align them by tapping edge of the stack lightly against a flat surface. This will prevent several sheets of paper from being drawn in all at once.

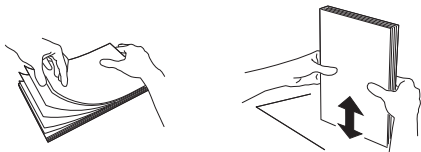

- 5. Insert the paper into the paper tray. You can load up to **250 sheets (80 g/m²)**.

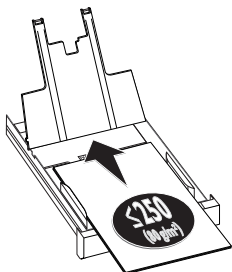

i Loading Pre-printed Material

If you would like to print on an input sheet (for example, forms or stationery), place the input sheet face down in the paper tray, with the top of the page towards the front.

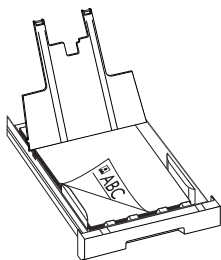

CAUTION!

! Forms from a Laser Printer!

Forms that have been printed out by a laser printer are not suitable for further printing.

- 6. Enclose the paper with the two side paper guides. Be sure not to enclose it so tightly that it bends.

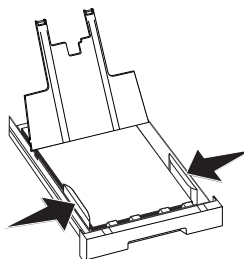

- 7. Close the paper tray cover.

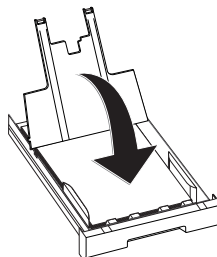

i Cover of the Paper Tray

If the cover of the paper tray has become detached, fasten the lid into the supports. Ensure that the flat side of the cover (with the inscription) faces upwards.

- 8. Push the paper tray into the device all the way to the stopping point.

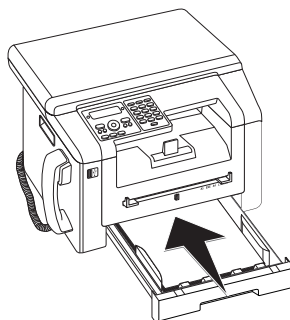

Load Paper into the Manual Paper Feed

1. Press **C**, **2** **0** **0** **2** and **OK**.
2. Select the manual paper feed using **▲/▼**.
3. Confirm with **OK**.
4. Load the paper into the manual paper feed on the front of the device.
5. Enclose the paper with the two side paper guides. Be sure not to enclose it so tightly that it bends.

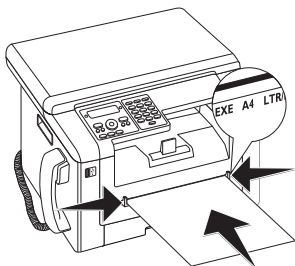

CAUTION!



Reset Settings

Reset the standard setting again after the print job so that the paper feed from the paper tray is guaranteed for incoming fax transmissions.

Loading Envelopes

You can print on envelopes directly using the manual paper feed.

CAUTION!



Unsuitable Envelopes!

Do not use envelopes with self-adhesive flaps, window envelopes or envelopes with metal fasteners.

1. Load the envelope into the manual paper feed on the front of the device. The short edge must face the direction of the device. The side which is to be printed should lay face up. The envelope flap must be face down on the left hand side.
2. Enclose the envelope with the two side paper guides. Ensure that the envelope is not inserted so tightly that it bends.

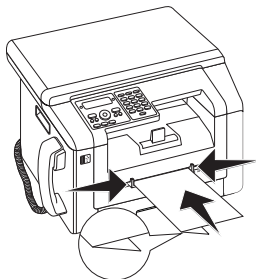

Inserting Slides and Labels

Use slides which are designed for copiers and laser printers as they must stand up to high temperatures and printing. The printing side is usually somewhat rougher than the reverse side.

You can insert slides and sheets of labels into the paper tray and into the manual paper feed. It is preferable to use the manual paper feed for printing on this print media (see also chapter *Load Paper into the Manual Paper Feed*, page 25).

CAUTION!



Unsuitable Slides and Labels!

Do not use slides which are designed for manual inscription or for an overhead projector. These slides can melt in the device and damage it.

Use sheets of labels for use in laser printers. The labels must cover the entire sheet otherwise they could peel off in the device.

Loading Pre-printed Material

CAUTION!



Forms from a Laser Printer!

Forms that have been printed out by a laser printer are not suitable for further printing.

Insert the Template into the Paper Tray

If you would like to print on an input sheet (for example, forms or stationery), place the input sheet face down in the paper tray, with the top of the page towards the front.

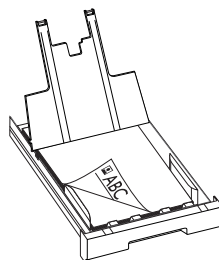

Load Templates into the Manual Paper Feed

If you would like to print on an input sheet (for example, forms or stationery), place the input sheet face up with the top of the page facing forwards (towards the device) into the manual paper feed.

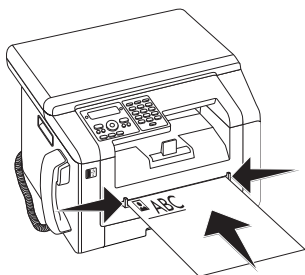

Print a List of Available Documents on USB Storage Medium

CAUTION!

Compatible USB Storage Media!

Ensure that the power of a USB device does not exceed the permitted amp limit of the USB connection. You can only connect **one** high power device (USB 2.0) to each USB connection. Do not connect additional devices—such as batteries, fans, charging devices—to your machine. The device only recognises storage media which are formatted with **FAT16** or **FAT32**. **NTFS** is not supported.

Analysing USB Storage Medium

If a lot of documents are saved on the USB storage medium, it can take a while for the USB storage medium to be analysed. You can interrupt the process at any time, by pressing .



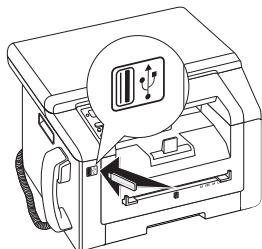

You can print a list of all the TXT-, JPEG-, and TIFF files on the connected USB storage medium.

1. Make sure that a USB storage medium is connected to the USB host port on the front or on the back-side of the device. Connect a USB storage medium as required.





Selection Menu for USB Storage Media

The selection menu for USB storage media appears on the display as soon as you connect a USB storage medium (USB stick, external hard drive etc.) to the USB host port on the front of the device.

2. Using  select PRINT LIST from the menu or press **C**,    and **OK**. The list is printed.

Access Function

You can also call the function by pressing **C**,    and **OK**.

CAUTION!

Removing USB Storage Media!

Never pull out the storage medium while the device is accessing it. This could cause data to be damaged or lost.

Print Document from USB Storage Medium

CAUTION!

Compatible USB Storage Media!

Ensure that the power of a USB device does not exceed the permitted amp limit of the USB connection. You can only connect **one** high power device (USB 2.0) to each USB connection. Do not connect additional devices—such as batteries, fans, charging devices—to your machine. The device only recognises storage media which are formatted with **FAT16** or **FAT32**. **NTFS** is not supported.

Analysing USB Storage Medium

If a lot of documents are saved on the USB storage medium, it can take a while for the USB storage medium to be analysed. You can interrupt the process at any time, by pressing .

You can print one or more of the TXT-, JPEG-, and TIFF files on the connected USB storage medium.

1. Make sure that a USB storage medium is connected to the USB host port on the front or on the back-side of the device. Connect a USB storage medium as required.

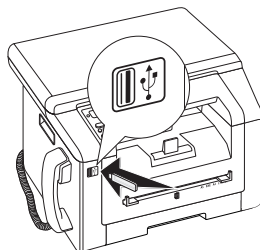

Selection Menu for USB Storage Media

The selection menu for USB storage media appears on the display as soon as you connect a USB storage medium (USB stick, external hard drive etc.) to the USB host port on the front of the device.

- Using $\blacktriangle/\blacktriangledown$ select PRINT FILE from the menu or press **C**, $\boxed{9}$ $\boxed{1}$ $\boxed{2}$ and **OK**.

Access Function

You can also call the function by pressing **C**, $\boxed{2}$ $\boxed{1}$ $\boxed{2}$ and **OK**.

Navigating within the Directory

Press **OK** to open a folder in the directory. Use **C** to return to the next upper level directory.

- Enter the initial letters or select the file you would like to print $\blacktriangle/\blacktriangledown$.
- Press **OK** to highlight the file. Files to be printed are flagged with a star (*).
- To add more files, select the file using the arrow keys and press **OK**. You can only select files from the same directory.

Select Files Using the Arrow Keys

You can select multiple successive files. Press \uparrow and **OK** to switch the function on/off. Highlight the desired files using $\blacktriangle/\blacktriangledown$. Once files have been selected, they cannot be removed from the selection.

- Press \blacklozenge to complete the selection.

Navigating in the Menu

Press \odot to close the menu and return to the starting mode.

- Enter the number of times you would like to copy the document (maximum of $\boxed{9}$ $\boxed{9}$ copies).
- Confirm with **OK**.
- Using $\blacktriangle/\blacktriangledown$ select the paper source.
- Confirm with **OK**.
- Use $\blacktriangle/\blacktriangledown$ to select the desired paper format. Follow the specifications in the technical data.
- Confirm with **OK**.
- Using $\blacktriangle/\blacktriangledown$ select the weight of the inserted paper.
- Press \blacklozenge to start the printing process.

CAUTION!



Removing USB Storage Media!

Never pull out the storage medium while the device is accessing it. This could cause data to be damaged or lost.

Delete Files on USB Storage Medium

CAUTION!



Compatible USB Storage Media!

Ensure that the power of a USB device does not exceed the permitted amp limit of the USB connection. You can only connect **one** high power device (USB 2.0) to each USB connection. Do not connect additional devices—such as batteries, fans, charging devices—to your machine. The device only recognises storage media which are formatted with **FAT16** or **FAT32**. **NTFS** is not supported.



Analysing USB Storage Medium

If a lot of documents are saved on the USB storage medium, it can take a while for the USB storage medium to be analysed. You can interrupt the process at any time, by pressing \odot .

You can delete files from the connected USB storage medium.

- Make sure that a USB storage medium is connected to the USB host port on the front or on the back-side of the device. Connect a USB storage medium as required.

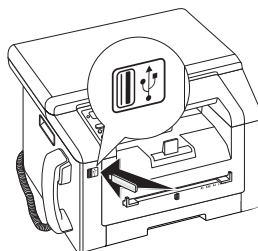

Selection Menu for USB Storage Media

The selection menu for USB storage media appears on the display as soon as you connect a USB storage medium (USB stick, external hard drive etc.) to the USB host port on the front of the device.

- Using $\blacktriangle/\blacktriangledown$ select DELETE from the menu or press **C**, $\boxed{9}$ $\boxed{1}$ $\boxed{5}$ and **OK**.



Navigating within the Directory

Press **OK** to open a folder in the directory. Use **C** to return to the next upper level directory.

- Enter the initial letters or select the file you would like to delete $\blacktriangle/\blacktriangledown$.
- Press **OK** to highlight the file. Files that are to be deleted are flagged with a star (*).
- To add more files, select the file using the arrow keys and press **OK**. You can only select files from the same directory.

**Select Files Using the Arrow Keys**

You can select multiple successive files. Press **↑** and **OK** to switch the function on/off. Highlight the desired files using **▲/▼**. Once files have been selected, they cannot be removed from the selection.

- Press **◇** to complete the selection.

**Navigating in the Menu**

Press **○** to close the menu and return to the starting mode.

- Confirm the deletion with **OK**.

CAUTION!**Delete Files!**

You cannot interrupt the deleting process. Deleted files cannot be restored.

CAUTION!**Removing USB Storage Media!**

Never pull out the storage medium while the device is accessing it. This could cause data to be damaged or lost.

Print Calendar

Your device prints a weekly overview as a calendar page for you – for the current week, the coming week or a freely selectable week.

- Press **C**, **[8][5]** and **OK**.
- Using **▲/▼**, select whether you would like to print a calendar page of the current week, the coming week or a freely selectable week.
- Confirm with **OK**.
- User-Defined Week:** Enter the year and the week (two digits for each field) for which you would like to print a calendar page for example **[2][5][4][0]** for the year 2025, week 40.
- Confirm with **OK**.

Sudoku: Printing a Game

Sudoku is a Japanese number puzzle. The game has 3×3 squares divided into 3×3 fields. Depending on the difficulty level, lesser or more digits are already given at the beginning of the game. The aim of the game is to fill digits from 1 to 9 in the game field in such a way that each digit appears only once in a row, a column and each of the nine blocks. There is only one solution.

Printing a Game

- Press **C**, **[8][6][1]** and **OK**.
- Using **▲/▼** select the difficulty level.
- Confirm with **OK**.
- Enter, how many copies of the Sudoku you would like to print (maximum 9 copies).
- Confirm with **OK**.

- Using **▲/▼** select if you would like to print the solution.
- Confirm with **OK**.

Printing the Last Game Again

- Press **C**, **[8][6][2]** and **OK**.
- Enter, how many copies of the Sudoku you would like to print (maximum 9 copies).
- Confirm with **OK**.
- Using **▲/▼** select if you would like to print the solution.
- Confirm with **OK**.

Printing the Solution

**Last Solution Available**

The solution of the last printed game is saved. The solutions of earlier games are no longer available.

Press **C**, **[8][6][3]** and **OK**.

Sudoku for Every Day

You can have a new Sudoku automatically printed each day.

- Press **C**, **[8][6][4]** and **OK**.
- Enter the time, e.g. **[1][4][0][0]** for 2 pm.
- Confirm with **OK**.
- Using **▲/▼** select the difficulty level.
- Confirm with **OK**.
- Enter, how many copies of the Sudoku you would like to print (maximum 9 copies).
- Confirm with **OK**.
- Using **▲/▼** select if you would like to print the solution.
- Confirm with **OK**.
- Using **▲/▼** indicate whether you would like to turn printing on or off.
- Confirm with **OK**.

**Switching Off Function**

You can turn off the daily Sudoku print by selecting the function as described above and by switching off the automatic printing under point 10.

8 Copier

Specifications for Documents	
Width of Documents	208–218 mm
Length of Documents	277–600 mm
Paper Weight of the Documents	60-90 g/m ²
Capacity	50 page (60-90 g/m ²)
Manufacturer's Recommendation for Optimum Operation	A4 · A5 · Letter · Legal (80 g/m ²)

CAUTION!



Unsuitable Documents!

Do not insert any documents into the device that ...

... are wet, have been edited with correction fluid, are soiled or have a coated surface.

... that are written on with a soft pencil, with paint, chalk or charcoal.

... originate from newspapers or magazines (printing ink).

... that are held together with office or notebook staples or with tape or glue.

... are pasted with note papers.

... are creased, crumpled or torn.

Loading Documents

1. Open the scanner cover.

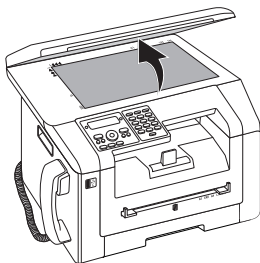

2. Lay the document onto the scanner glass with the written side down.

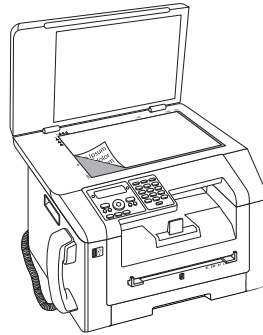

3. Align the document with the rear left corner of the scanner glass (arrow marks). The markings on the scanner border for the A4 and A5 formats will help you to position the document correctly.

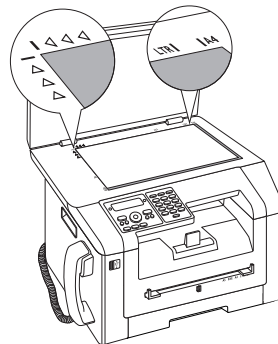

Enlarge Detail

If you would like to copy a detail (such as a graphic) of your document, position the document so that the detail view is close to the source. Using the zoom function, you can separate the desired area from rest of the document.

4. Close the scanner cover.

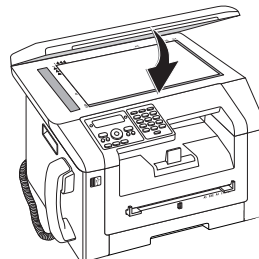



Adjust Scanner Cover

The scanner cover is equipped with adjustable hinges, allowing you to lay even thicker documents (e.g. books) in the flatbed scanner. Carefully lift the scanner cover so that it rests as evenly as possible.

Use clear sheets of plastic when copying three-dimensional objects (e.g. coins, flowers) to avoid damaging the scanner glass.

CAUTION!



Do Not Press on the Scanner Cover!

Do not press forcefully on the scanner cover when you scan thicker documents or three-dimensional items, this could damage the scanner cover and/or the scanner glass.

Make Copy Using Standard Settings

In the starting mode, the selected settings for resolution, magnification/reduction factor, selected paper size and simplex or duplex appear in the display.

1. Insert the document.
2. Press **COPY** twice. The copy is created.



ECO button

Press **COPY** and **ECO** to make a copy using the toner saving function.



Access Function

You can also call the function by pressing **C**, **1** **1** and **OK**.

Modifying the Settings



Settings for the Next Print Job

Using this function, select the settings for the next print job. Change the basic settings using the functions of chapter *Settings* (see also chapter *Settings*, page 51).

Set Resolution

Press **RES**. The configured resolution appears on the display. Press **RES** again to change the setting. You can choose between:

AUTO—Optimised adjustment for all types of documents

TEXT—For texts with small print or drawings

QUALITY—For documents with many details

PHOTO—For the highest resolution



Modifying the Basic Settings

Modify the basic setting by pressing **C**, **1** **0** **3** and **OK**.

Setting the Zoom Parameter

1. Press **ZOOM**. The magnification/reduction factor appears on the display.

2. Select the desired setting using **▲/▼**. Standard values are saved, for example, for compressing A4 to A5 or for adjusting the European DIN formats to American letter and legal formats
3. Confirm with **OK**.

Select One Side/Both Side Printing (Simplex/Duplex)

Press **DUPLEX**, to select double sided printing (Duplex). Press **DUPLEX**, twice to select single side printing (Simplex).



Modifying the Basic Settings

Modify the basic setting by pressing **C**, **1** **0** **1** and **OK**.

Adjust contrast

1. Press **CONTRAST**.
2. Set the desired contrast using **▲/▼**.
 - /1—Reduces the contrast / typeface appears lighter
 - 4 (Factory settings)—Optimized adaptation for all documents
 - +/7—Increases the contrast / typeface appears darker (for example, documents with faint print)
3. Confirm with **OK**.

Creating Multiple Copies

1. Insert the document.
2. Enter the number of times you would like to copy the document (maximum of **9** **9** copies). You can also change the number by pressing **▲/▼**.
3. Press **COPY** twice.



ECO button

Press **COPY** and **ECO** to make a copy using the toner saving function.

Creating Crystal Copy with Image and Text Enhancement (Crystal)

Your device has the image and text enhancement function Crystal with which you achieve optimal printing and copying quality for your documents.

Crystal automatically performs all adjustments and corrections with regard to image sharpness, colour management and contrast in order to obtain the best possible printing quality. Exposure errors are also corrected (underexposed images are brightened or parts of the image with extremely different contrasts are brought into balance).

1. Insert the document.
2. Press **COPY**.
3. Select with **▲/▼** **CRYSTAL TEXT**.
4. Confirm with **OK**.

5. A preview of the document is scanned for analysis. Thereafter, the device creates the Crystal copy for the document. The profile with the settings is saved for other documents.

Create Multiple Crystal Copies with a Saved Profile

1. Press **C**, **[1]** **[5]** and **OK**.
2. Select with **▲/▼** **PRE SCAN**.
3. Confirm with **OK**.
4. A preview of the document is scanned for analysis. Thereafter, the device creates the Crystal copy for the document. The profile with the settings is saved for other documents.
5. If you would like to copy other documents with the same settings, select using **▲/▼** **PREV. PROFILE**. Only the last profile used is saved.
6. Confirm with **OK**.

Make Copies Using the Second Profile

In a profile, you may save settings that you would like to use fairly often, for example, for copying of a frequently-used document-type (see also chapter *Configure Settings for Second Profile*, page 32).

Make Copy Using the Second Profile

1. Insert the document.
2. Press **COPY**.
3. Select the second profile using **▲/▼**.



Access Function

You can also call the function by pressing **C**, **[1]** **[2]** and **OK**.

4. Press **COPY**.

Make Several Copies Using the Second Profile

1. Insert the document.
2. Enter the number of times you would like to copy the document (maximum of **[9]** **[9]** copies). You can also change the number by pressing **▲/▼**.
3. Press **COPY**.
4. Select the second profile using **▲/▼**.



Access Function

You can also call the function by pressing **C**, **[1]** **[2]** and **OK**.

5. Press **COPY**.



ECO button

Press **COPY** and **ECO** to make a copy using the toner saving function.

Make Copies Using User-Defined Settings



Make Copies

You can start the copying process at any time, by pressing **COPY**. Press **ECO** to make a copy using the toner saving function.

1. Insert the document.
2. Press **COPY**.
3. Use **▲/▼** to select the desired profile.
4. Confirm with **OK**.
5. Using **▲/▼** select the paper source.
6. Confirm with **OK**.
7. **For Paper in the Manual Paper Feed:** Use **▲/▼** to select the desired paper format.
8. Confirm with **OK**.
9. **For Paper in the Manual Paper Feed:** Use **▲/▼** to select the weight of the inserted paper.
10. Confirm with **OK**.
11. Select the desired resolution using **▲/▼**:
 - AUTO—Optimised adjustment for all types of documents
 - TEXT—For texts with small print or drawings
 - QUALITY—For documents with many details
 - PHOTO—For the highest resolution
12. Confirm with **OK**.
13. Set the desired contrast using **▲/▼**.
 - /1—Reduces the contrast / typeface appears lighter
 - 4 (Factory settings)—Optimized adaptation for all documents
 - +/7—Increases the contrast / typeface appears darker (for example, documents with faint print)
14. Confirm with **OK**.
15. Using **▲/▼**, select the desired level of brightness:
 - /1—Reproduction is lighter
 - 4 (Factory settings)—Optimized adaptation for all documents
 - +/7—Reproduction is darker
16. Confirm with **OK**.
17. Select one-sided print (Simplex) or double-sided print (Duplex) using **▲/▼**.
18. Confirm with **OK**.
19. Select whether the copies should be output sorted or unsorted using **▲/▼**.
20. Press **COPY**.

Make Enlarged or Compressed Copies

EN



Make Copies

You can start the copying process at any time, by pressing **COPY**. Press **ECO** to make a copy using the toner saving function.

1. Insert the document.
2. Press **COPY**.
3. Select with **▲/▼ ZOOM**.
4. Confirm with **OK**.



Access Function

You can also call the function by pressing **C**, **1** **3** and **OK**.

5. Enter the number of times you would like to copy the document (maximum of **9** **9** copies).
6. Confirm with **OK**.
7. You can make copies of the document that are enlarged or that are compressed in size. Size compression is possible down to 25 percent of the size of the original, and enlargements of up to 400 percent can be made. Enter the the desired value using the numeric keypad.



Select the Preset Values

Using **▲/▼** select from the preset values. Standard values are saved, for example, for compressing A4 to A5 or for adjusting the European DIN formats to American letter and legal formats

8. Press **COPY**, to start the copying process or **OK**, to configure further settings (see also chapter *Make Copies Using User-Defined Settings*, page 31).

Copying both Sides of a Document onto One Side (= Business Card Copy)

Using the business card copy, you can copy both sides of a small document (for example of a business card) onto one page

CAUTION!



Reproduction Not Permitted

The reproduction of certain documents (e.g. by scanning, printing, copying) is prohibited in many countries. Observe the legal notes for reproduction of certain documents in the appendix (page (see also chapter *Appendix*, page 77)).

1. Insert the document. Place the document in the upper half of the scanning area.

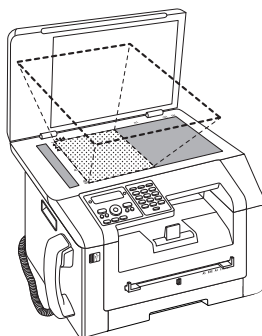

Document Size

The document cannot be larger than half of the print paper (for example) A5 document with A4 printing paper)

2. Press **COPY**.
3. Select with **▲/▼ ID CARD**.
4. Confirm with **OK**.



Access Function

You can also call the function by pressing **C**, **1** **6** and **OK**.

5. The first page of the document is scanned.
6. Turn the document over when the corresponding messages appear on the display. Place it in the same place as the first page.
7. Confirm with **OK**. The second page of the document is scanned and the copy is created.

Configure Settings for Second Profile

Select One Side/Both Side Printing (Simplex/Duplex)

1. Press **C**, **1** **0** **6** **1** and **OK**.
2. Select one-sided print (Simplex) or double-sided print (Duplex) using **▲/▼**.
3. Confirm with **OK**.

Set Resolution

1. Press **C**, **1** **0** **6** **3** and **OK**.
2. Select the desired resolution using **▲/▼**:
AUTO—Optimised adjustment for all types of documents
TEXT—For texts with small print or drawings
QUALITY—For documents with many details
PHOTO—For the highest resolution
3. Confirm with **OK**.

Adjust contrast

1. Press **C**, **1** **0** **6** **4** and **OK**.
2. Set the desired contrast using **▲/▼**.
 - /1—Reduces the contrast / typeface appears lighter
 - 4 (Factory settings)—Optimized adaptation for all documents
 - +/?—Increases the contrast / typeface appears darker (for example, documents with faint print)
3. Confirm with **OK**.

Setting the Brightness

1. Press **C**, **1** **0** **6** **5** and **OK**.
2. Using **▲/▼**, select the desired level of brightness:
 - /1—Reproduction is lighter
 - 4 (Factory settings)—Optimized adaptation for all documents
 - +/?—Reproduction is darker
3. Confirm with **OK**.

9 Telephone Functions

For information on how to connect additional telephones and which functions are available to you, please refer the chapter on Telephone Lines and Additional Devices, (see also chapter *Telephone Lines and Additional Devices*, page 58).



Enter the dialing code

You can enter a dialing code for the connection to a telecommunications provider or a network, for example. This number will be placed automatically before every number that you dial (see also chapter *Enter the dialing code*, page 58).

Placing a Call on the Device

Dial the desired number. There are several ways to do this: Then pick up the handset.



Direct Dialing

You can also lift up the receiver first, then dial a number. The dialing process begins immediately.

Manual Dialling: Dial the desired number using the numeric keypad.

Telephone Book:

1. Press **☐**.



Access Function

You can also search for an entry in the telephone book by pressing **C**, **5** **☐** **☐** **☐** and **OK**.

2. Select an entry using **▲/▼**. Enter the starting letters with the numeric keypad to quickly navigate through the telephone book.

Redial / caller list: The redial / caller list contains the last numbers dialled and the last calls received (♦ indicates the numbers dialled, † the calls received and * the calls missed).

1. Press **☉**.
2. Select an entry using **▲/▼**.

Chain Dialling

You can combine and edit manually entered digits and saved entries, before the dialling process starts. If you have saved, for example, the telephone number prefix of an inexpensive telephone service provider (call-by-call) as a telephone book entry, select this entry and manually enter the subsequent telephone number or select another saved entry.

Getting Outside Line

Private branch exchanges (PABX) are typical in many offices and some households. You must dial an outside line access code in order to get a connection to the public telephone network (PSTN) from a PABX.

Enter the outside line access code with which you reach the public telephone network before you enter the desired number or select a stored entry. The outside line access code is usually **☐**.



Incorrect Outside Line Access Code

In rare cases, the outside line access code may be a different number or a two-digit number. For older telephone systems, the outside line access code can be **R** (= Flash). Press **R** to enter this outside line access code. If the connection to the public telephone network is not possible, contact your telephone system supplier.



Connection to Private Automatic Branch Exchange

If you operate your device permanently on an extension, save the outside line access code (see also chapter *Set up Private Branch Exchange (PABX)*, page 58).

Insert Dialling Pause

It may be necessary to insert a dial pause in telephone number, for example, for a direct-inward dialling number, a sub-address or in a long distance number. Press **R**. The second part of the number is dialled only after a short pause.

Calling Additional Telephone Functions

(Function is not supported in all countries and networks)







You can use additional telephone functions with your device for example call toggling, three-way call or call forwarding. Contact your telephone company to inquire whether or not these functions are available for your connection. The signal to the switchboard to call these services is a short line interruption (Hook Flash). Press the **R** key to call the additional telephone functions. How to call up the functions, depends on your telephone company.

Calling Line Identification (CLIP)

The number of an incoming call appears on the display. For this function to work, the Calling Line Identification Presentation (CLIP) must be activated for your telephone line. Enquire with your telephone company. Caller Line Identification may be associated with a fee.

Missed Calls

You can find reference to missed calls in the redial/caller list.

1. Press .
2. Page through the dialled numbers, the calls received and calls missed in the list using / ( indicates the numbers dialled,  the calls received and  the calls missed).



Displaying Telephone Book Names

Your device displays the name with which you have saved the number in the telephone book. The number and name will not be shown if the caller suppresses his number.

10 Telephone Book of the Device



Calling the Web Interface

You can also edit the entries of the telephone book with the device's web interface (see also chapter *Web Interface*, page 18).

You can store new entries, search for entries as well as set and edit groups. You can save up to 250 entries in the telephone book of your device.



Navigating in the Editor

You can move the cursor using ▲/▼. Use C to delete individual characters. Press ⏹ to close the menu and return to the starting mode.

Looking up an Entry

1. Press **□□**.



Access Function

You can also search for an entry in the telephone book by pressing C, **5** **1** **1** and **OK**.

2. Select an entry using ▲/▼.

Saving Entry



No Repeat Entries

You cannot save two entries under the same name.

1. Press C, **5** **1** **2** and **OK**.
2. Enter the name. You can enter characters using the numeric keys (see key labels). Enter special characters using **0**. Press the respective key several times until the desired character or special character appears on the display.



Navigating in the Editor

You can move the cursor using ▲/▼. Use C to delete individual characters.

3. Confirm with **OK**.
4. Enter the number using the number pad.
5. Confirm with **OK**.



Number from the Last Number Redial List

You can retrieve a saved number from the list of the last numbers dialled and last calls received (redial/caller list). Press **☉**. Select an entry using ▲/▼. Confirm with **OK**.



Outside Line Access Code

If you have set your device up to work on a public telephone network (see *Private Branch Exchange*) and entered the outside line access code, save the number without the outside line access code (see also chapter *Set up Private Branch Exchange (PABX)*, page 58).

6. You can assign a ring tone to the number. Use ▲/▼ or the number buttons **1** to **7** to select a ring tone.

7. Confirm with **OK**.



Assigning the Standard Ring Tone

Select **1**, in order to assign the standard ring tone to the number.

8. Select the speed for fax transmissions to this recipient. Normally you can select the highest speed. Set a lower transmission speed if you are sending faxes into networks with poor line quality.
9. Confirm with **OK**. The entry is saved.

Edit Entry

1. Press C, **5** **1** **4** and **OK**.
2. Using ▲/▼ select the entry which you would like to edit.
3. Confirm with **OK**.
4. Edit the name.
5. Confirm with **OK**.
6. Edit the number.
7. Confirm with **OK**.
8. You can assign a ring tone to the number. Use ▲/▼ or the number buttons **1** to **7** to select a ring tone.
9. Confirm with **OK**.



Assigning the Standard Ring Tone

Select **1**, in order to assign the standard ring tone to the number.

10. Select the speed for fax transmissions to this recipient. Normally you can select the highest speed. Set a lower transmission speed if you are sending faxes into networks with poor line quality.
11. Confirm with **OK**. The entry is saved.

Delete an Entry

1. Press C, **5** **1** **5** and **OK**.
2. Select with ▲/▼ **DELETE: SINGLE**.
3. Confirm with **OK**.
4. Using ▲/▼ select the entry which you would like to delete.
5. Confirm with **OK**.
6. Select with ▲/▼ **DELETE: YES**.
7. Confirm with **OK**.

Delete all Entries

CAUTION!



All Telephone Book Entries are Deleted!

This function deletes all entries and groups in your telephone book.

1. Press **C**, **[5]** **[1]** **[5]** and **OK**.
2. Select with **▲/▼** **DELETE: ALL**.
3. Confirm with **OK**.
4. Select with **▲/▼** **DELETE: YES**.
5. Confirm with **OK**.

Printing the Telephone Book

Printing List of all Entries

Press **C**, **[8]** **[3]** and **OK** to print a list of all saved entries and groups in the telephone book.

Printing an Individual Entry

1. Press **C**, **[5]** **[1]** **[1]** and **OK**.
2. Select an entry using **▲/▼**. Enter the initial letters with the letter keypad to quickly navigate through the telephone book.
3. Press **COPY**.

Groups

You can create groups containing several numbers. A message is sent to all members of this group in succession. A group is displayed as an individual telephone book entry.

Creating Group

1. Press **C**, **[5]** **[1]** **[3]** and **OK**.
2. Enter a name for the group.
3. Confirm with **OK**.
4. Enter the initial letters or select the entry you would like to add to the group using **▲/▼**.
5. Entries which belong to the group are highlighted with a star (*). Add other members to the group by selecting the entries and press **OK**. Remove group members by selecting the highlighted entry and press **OK**.
6. Press **◇** to save the group.



Saving Group

You can also save the groups using **▲/▼** to select **ACCEPT GROUP**. You can find this menu entry at the end of the list of stored names. Confirm with **OK**.

Edit Group

1. Press **C**, **[5]** **[1]** **[4]** and **OK**.
2. Using **▲/▼** select the group you would like to edit.
3. Confirm with **OK**.
4. If necessary, enter a new name for the group.
5. Confirm with **OK**.
6. Entries which belong to the group are highlighted with a star (*). Add other members to the group by selecting the entries and press **OK**. Remove group members by selecting the highlighted entry and press **OK**.
7. Press **◇** to save the group.



Saving Group

You can also save the groups using **▲/▼** to select **ACCEPT GROUP**. You can find this menu entry at the end of the list of stored names. Confirm with **OK**.

Deleting a Group



Entries are Not Deleted

This function only deletes the group but not the telephone book entries contained in it.

1. Press **C**, **[5]** **[1]** **[5]** and **OK**.
2. Select with **▲/▼** **DELETE: SINGLE**.
3. Confirm with **OK**.
4. Using **▲/▼** select the group you would like to delete.
5. Confirm with **OK**.
6. Select with **▲/▼** **DELETE: YES**.
7. Confirm with **OK**.

Exporting/Importing the Telephone Book

You can save your telephone book entries onto a USB storage medium or import your entries from a USB storage medium.



Compatible with Microsoft Outlook

The headings and the order of the fields correspond to a contact in Microsoft Outlook. The following fields are used: last name, business telephone number, email address as well as two additional fields for further information.

Saving Telephone Book onto USB Storage Medium

1. Make sure that a USB storage medium is connected to the USB host port on the front or on the back-side of the device. Connect a USB storage medium as required.

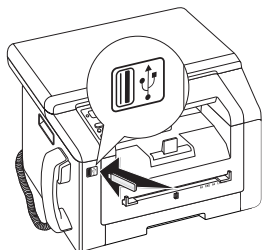

2. Press **C**, **5** **1** **8** and **OK**. The telephone book is saved on the USB storage medium.

Load Telephone Book from USB Storage Medium



Data Format

The entries must be saved to the file „phone-book.csv“ in the root directory of the USB storage medium. The data in the file must be separated by a comma „,“. The headings and the order of the fields correspond to a contact in Microsoft Outlook.

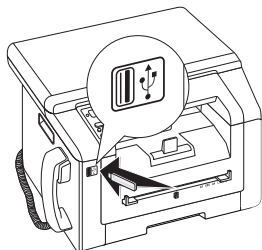

1. Press **C**, **5** **1** **7** and **OK**. The entries are added to the existing entries. Current entries with the same name will not be overwritten.

11 Fax



Enter the dialing code

You can enter a dialing code for the connection to a telecommunications provider or a network, for example. This number will be placed automatically before every number that you dial (see also chapter *Enter the dialing code*, page 58).

Send a Fax Using Standard Settings

Your fax message will be sent using the standard settings. If you would like to adjust the settings yourself (for example resolution or contrast) for a fax transmission use function *Send Fax Later*, page (see also chapter *Sending Fax Later (= Timer Function)*, page 41)).

1. Insert the document.
2. Press **FAX**.



Call Up Function Immediately

You can also call the function by pressing **C**, **4** **1** and **OK**.

3. Enter the desired number using the numeric keypad or select a saved entry.
4. Press **FAX** or **◇**.



Automatic Redial

If the subscriber is busy, the device dials the number again after some time. Press **⏏**, in order to cancel the transmission process. After the transmission, the device prints out a transmission report depending on the settings.

Specifications for Documents	
Width of Documents	208–218 mm
Length of Documents	277–600 mm
Paper Weight of the Documents	60–90 g/m ²
Capacity	50 page (60–90 g/m ²)
Manufacturer's Recommendation for Optimum Operation	A4 · A5 · Letter · Legal (80 g/m ²)

CAUTION!



Unsuitable Documents!

- Do not insert any documents into the device that ...
- ... are wet, have been edited with correction fluid, are soiled or have a coated surface.
 - ... that are written on with a soft pencil, with paint, chalk or charcoal.
 - ... originate from newspapers or magazines (printing ink).
 - ... that are held together with office or notebook staples or with tape or glue.
 - ... are pasted with note papers.
 - ... are creased, crumpled or torn.

EN

Loading Documents

1. Open the scanner cover.

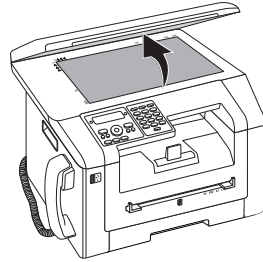

2. Lay the document onto the scanner glass with the written side down.

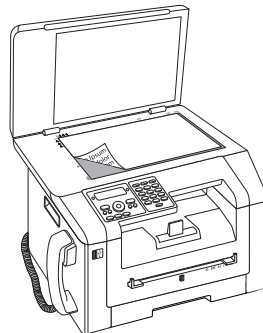

- Align the document with the rear left corner of the scanner glass (arrow marks). The markings on the scanner border for the A4 and A5 formats will help you to position the document correctly.

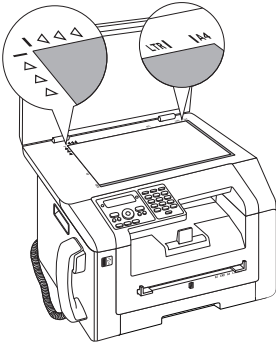

Enlarge Detail

If you would like to copy a detail (such as a graphic) of your document, position the document so that the detail view is close to the source. Using the zoom function, you can separate the desired area from rest of the document.

- Close the scanner cover.

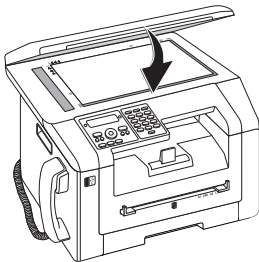

Adjust Scanner Cover

The scanner cover is equipped with adjustable hinges, allowing you to lay even thicker documents (e.g. books) in the flatbed scanner. Carefully lift the scanner cover so that it rests as evenly as possible.

Use clear sheets of plastic when copying three-dimensional objects (e.g. coins, flowers) to avoid damaging the scanner glass.

CAUTION!



Do Not Press on the Scanner Cover!

Do not press forcefully on the scanner cover when you scan thicker documents or three-dimensional items, this could damage the scanner cover and/or the scanner glass.

Dialling a Number

Dial the desired number. There are several ways to do this:

Manual Dialling: Dial the desired number using the numeric keypad.

Telephone Book:

- Press



Access Function

You can also search for an entry in the telephone book by pressing **C**, and **OK**.

- Select an entry using . Enter the starting letters with the numeric keypad to quickly navigate through the telephone book.

Redial / caller list: The redial / caller list contains the last numbers dialled and the last calls received (indicates the numbers dialled, the calls received and the calls missed).

- Press .
- Select an entry using .

Chain Dialling

You can combine and edit manually entered digits and saved entries, before the dialling process starts. If you have saved, for example, the telephone number prefix of an inexpensive telephone service provider (call-by-call) as a telephone book entry, select this entry and manually enter the subsequent telephone number or select another saved entry.

Getting Outside Line

Private branch exchanges (PABX) are typical in many offices and some households. You must dial an outside line access code in order to get a connection to the public telephone network (PSTN) from a PABX.

Enter the outside line access code with which you reach the public telephone network before you enter the desired number or select a stored entry. The outside line access code is usually .



Incorrect Outside Line Access Code

In rare cases, the outside line access code may be a different number or a two-digit number. For older telephone systems, the outside line access code can be **R** (= Flash). Press **R** to enter this outside line access code. If the connection to the public telephone network is not possible, contact your telephone system supplier.



Connection to Private Automatic Branch Exchange

If you operate your device permanently on an extension, save the outside line access code (see also chapter *Set up Private Branch Exchange (PABX)*, page 58).

Insert Dialing Pause

It may be necessary to insert a dial pause in telephone number, for example, for a direct-inward dialling number, a sub-address or in a long distance number. Press **R**. The second part of the number is dialled only after a short pause.

Sending Fax Later (= Timer Function)

This function is only available if you have set up your device in such a way that fax messages are sent from the memory (see also chapter *Set Fax Transmission from the Memory*, page 55).

If you would like to make use of the lower telephone tariffs or if the recipient can be reached at some specific time only, you can send the fax at a later time—within 24 hours.

1. Insert the document.
2. Press **FAX**.
3. Enter the desired number using the numeric keypad or select a saved entry.
4. Confirm with **OK**.
5. Enter the time, at which the document should be transmitted, e.g. **[1][4][0][0]** for 2 pm.
6. Confirm with **OK**.
7. Select the desired resolution using **▲/▼**:
 DEFAULT—For documents without special features
 FINE—For texts with small print or drawings
 SFINE—For documents with many details
 PHOTO—For photos
8. Confirm with **OK**.
9. Set the desired contrast using **▲/▼**.
 -/1—Reduces the contrast / typeface appears lighter
 4 (Factory settings)—Optimized adaptation for all documents
 +/7—Increases the contrast / typeface appears darker (for example, documents with faint print)
10. Confirm with **OK**.
11. After a short warm up phase, the device will read the document into the memory and will send out the fax at the specified time.



Deleting a Job

To cancel a scheduled fax transmission, simply delete the document from the jobs list (see also chapter *Jobs*, page 45).

Sending Fax Manually

1. Insert the document.
2. Press **↵**.

3. Enter the desired number using the numeric keypad or select a saved entry.
4. Press **FAX** or **↵**.



Start Fax Reception from Additional Telephone

You can start the fax reception from an additional telephone that is connected to the device by pressing ***[5]**:

Using Fax Templates

Five fax templates, which you can use, are stored in your device. With these templates you can quickly create, for example, a short fax note or an invitation.

1. Press **C**, **[4][5]** and **OK**.
2. Use **▲/▼** to select the template you would like to print.
3. Confirm with **OK**. The device prints the template.
4. Fill the template and send it to the desired recipient per fax.

Faxing with the Companion Center SFX

With the software *Companion Center SFX* you can send, receive and manage faxes on your computer. You can either send scanned documents or files saved on the computer. With the cover sheet editor, you can design your own cover pages for your faxes, or use an existing document as the cover sheet. Apart from that, you can select from numerous fax settings.

1. Start the software *Companion Center SFX*, by clicking on the *Companion Center SFX* icon on your desktop or selecting **Start > Programs > Companion Center SFX > Laser SFX > Companion Center SFX** in the Start Menu.
2. The light in the upper-right corner shows whether or not the device is connected to the computer and is functioning properly.
3. Selecting the **Fax** tab.

Sending a Fax

1. Click on **Send**.

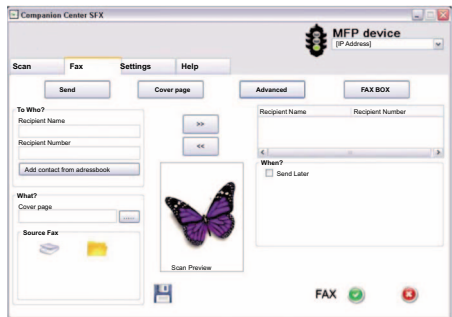

- In the field **To Who?** enter the name of the recipient under **Recipient Name**.
- In **Recipient Number**, enter the recipient's fax number.



Add Recipients from the Telephone Book

Click on **Add contact from addressbook** to access the device's telephone book.

- Click on **>>** to add the recipients to the list.



Sending to Multiple Recipients (= Broadcasting)

You can send one fax to multiple recipients in succession. Enter other recipient names and numbers or select entries from the telephone book. Click on **>>** to add the recipients to the list. Click on **>>** to remove a recipient from the send list.

- Under **Source Fax**, select whether you want to scan a document with the device or send a file that is already saved on the computer.
- Scan a document:** Insert the document into the device. Select the desired resolution.
- Sending a file:** Select the saved file (file format *.TIFF or *.FAX).
- If you would like to add a cover/title page to your fax, select the saved file under **Cover page** (file format *.TIFF).



Create Cover/Title Page with Editor

With the editor, you can create your own cover/title page for your fax. Click on **Cover page** (see also chapter *Create Cover/Title Page with Editor*, page 42).

- Click on **Fax** in order to send the fax to all recipients in the send list.

Sending Fax Later (= Timer Function)

If you would like to take advantage of cheaper telephone rates or if the recipient is only available at certain times, you can send the fax a later time.

- In the field **When?**, activate the function **Send Later**.
- Select the time and date that the document is to be sent.
- Click on **Fax**. The fax will be sent automatically at the specified time.

Send Fax from a Program

You can send a file as a fax from any program with a printing function—such as, for example, a word-processing or text-editing program. The documents do not need to be printed out already.

- In the program, click on the printing function.
- Select **FAX Laser SFX** as the printer.
- The software **Companion Center SFX** opens the window for sending faxes.

Create Cover/Title Page with Editor

With the cover sheet editor, you can design your own cover pages for your faxes, or use an existing document as the cover sheet.

- Click on **Cover page**.



- Activate the function **With the cover page:**
- Under **Sender** enter the data that is to appear on the cover sheet.
- Under **Subject**, enter a short title for your fax. Under **Comments** you are able to add a note.
- In **Recipient**, enter the recipient's information.
- You can save created cover sheets as templates. Click on **New** in order to open the template editor and save a new template. Select an existing cover sheet template from the list of created templates.

Managing Faxes with the Fax Manager

The **FAX Manager** shows you the received faxes and provides you an overview of the status of the sent faxes. The outbox and inbox logs are automatically printed when their contents fill a page. After the automatic printing, the device creates a new journal.

- Click on **FAX BOX**.

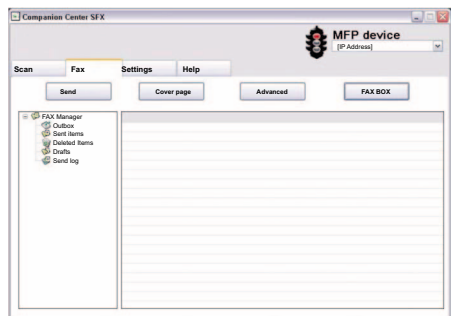

- 2. Select the desired folder.
 - Outbox**—Faxes that have not yet been sent (current send requests, delayed send requests, interrupted send requests)
 - Sent items**—Sent faxes
 - Deleted Items**—Deleted faxes (= recycle bin)
 - Drafts**—Saved faxes that have not yet been sent
 - Send log**—Information and transfer status of all faxes

- 4. You can activate the following options.
 - Automatic printing of the sent document**—Prints the sent fax after the sending process is complete
 - Print the send report**—The transmission report will be printed after each successful fax transfer as well as after interrupted transfers.
 - Print the send log**—The send report is printed after every successful or interrupted transfer attempt.

Additional Options for Fax Transmission

- 1. Click on **Advanced**.

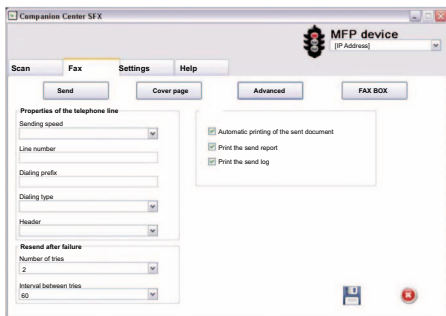

- 2. You have the following options available.
 - Sending speed**—The device adjusts the transmission speed to the line quality. Set a lower reception speed if this adjustment takes a long time or no connection is made.
 - Line number**—Enter your number.
 - Dialing prefix**—This dialing code is automatically added to the number before sending (= external access code).
 - Dialing type**—In some countries you can set the dialling mode to pulse dialling or tone dialling (DTMF tones).
 - Header**—Your name and number appear in the page header of each fax transmission. If you do not wish to send out your information, you can turn this function off.
- 3. With the following options you set the number of repeat attempts for incomplete fax transfers.
 - Number of tries**—Number of repeat attempts for interrupted fax transfers.
 - Interval between tries**—Duration between two transfer attempts

Fax Reception

If you have not changed the factory settings, received faxes will be printed out automatically. If there is no paper or toner in your device, the device will store incoming fax transmissions in its memory. The green lamp on the panel will be lit whenever there is a fax present in the memory. After you have loaded paper into the device or inserted a new toner cartridge, the saved messages are printed.

- Abort Fax Reception**

After receiving the first page of a fax message, you can abort the transmission at any time by pressing

The fax memory can store up to 200 pages. Follow the specifications in the technical data.

CAUTION!

Message Memory Full!
If the message memory is full, no additional messages can be received.

- Delete Fax Messages Sent**

If there are problems with printing out saved fax messages, a service code is available (see also chapter *Using Service Codes*, page 67).

Receiving Fax Manually

Select manual reception under fax reception mode (see also chapter *Setting the Fax Reception Mode*, page 54). The device will not receive faxes on its own. This setting is useful, when you want to receive faxes via a modem connected to a computer. You can start fax reception manually, by pressing .

Receive Faxes Silently

Set the number of rings (see also chapter *Setting the Number of Rings*, page 53) and set the fax reception mode to fax mode (see also chapter *Setting the Fax Reception Mode*, page 54), in order to receive faxes without your device ringing.

Receiving Faxes onto USB Storage Medium

With fax reception onto a USB storage medium, the device saves incoming faxes onto a connected USB storage medium. Fax messages are saved as TIFF files with receipt date and time.

Use the *Print Document from USB Storage Medium* function to print the saved fax messages (see also chapter *Print Document from USB Storage Medium*, page 26).

Function not available

The function is switched off if you remove the USB storage medium. You cannot use the *Protected Fax Reception* and *Receive Fax on USB Storage Medium* functions at the same time.

1. Make sure that a USB storage medium is connected to the USB host port on the backside of the device. Connect a USB storage medium to the USB host port as required.

Connecting USB Storage Medium on the Backside

The USB storage medium must be connected to the USB port on the the backside of the device in order to use this function.

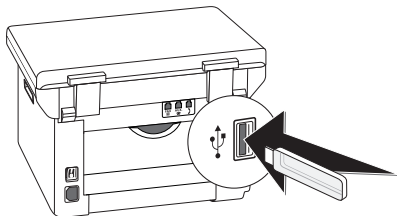

2. Press **C**, **9** **1** **4** and **OK**.

Access Function

You can also call the function by pressing **C**, **4** **4** and **OK**.

3. Use **▲/▼** to select whether you would like to turn the function on or off.
4. Confirm with **OK**.

Time Stamp

The device prints the date and the exact arrival time on every incoming fax received. This allows you to document the exact time at which you have received a fax transmission. A memory buffer in the device ensures that the correct date and time of reception will be maintained even after a power loss.

If the time stamp function is activated, incoming faxes will be stored in the fax memory. As soon as the last page has arrived, the arrival time is stored and the device prints out all the pages. You have the option of turning this function off (see also chapter *Switches Time Stamp On/Off*, page 55).

Setting Protected Fax Reception

You can secure your fax reception with a code. In that case, incoming faxes are not printed out, but rather are stored in the fax memory. Only after entering a PIN code can you print out these fax transmissions.

Function not available

You cannot use the *Protected Fax Reception* and *Receive Fax on USB Storage Medium* functions at the same time.

Entering the PIN Code

Default Access Code

The function is switched off with the factory-installed access code (0000). Change the access code to switch on the function. If you want to switch the function off enter the factory-installed code 0000 again.

1. Press **C**, **4** **0** **3** **3** and **OK**.

Entering the PIN Code

If you have already saved a code, the device will ask you to provide the old code first before you can enter a new code.

2. Enter a four-digit PIN code.
3. Confirm with **OK**.
4. Enter the code again for confirmation purposes.
5. Confirm with **OK**.

Switching On and Off

1. Press **C**, **4** **0** **3** **2** and **OK**.
2. Enter the four-digit PIN code.
3. Confirm with **OK**.
4. Use **▲/▼** to select whether you would like to turn the function on or off.
5. Confirm with **OK**.

Printing Out Fax Transmissions

1. Press **C**, **4** **0** **3** **1** and **OK**.
2. Enter the four-digit PIN code.
3. Confirm with **OK**. The stored fax transmissions are printed out and deleted from the memory.

Polling Faxes

With the fax polling function, you can retrieve faxes that lie ready in the dialled device.

Polling Faxes Directly

1. Press **C**, **4** **2** and **OK**.
2. Enter the desired number using the numeric keypad or select a saved entry.
3. Press **◇**.

Time-Deferred Polling

1. Press **C**, **4** **2** and **OK**.
2. Enter the desired number using the numeric keypad or select a saved entry.
3. Confirm with **OK**.
4. Enter the time, at which the document should be polled, e.g. **1** **4** **0** **0** for 2 pm.
5. Confirm with **OK**.
6. The device is now in standby mode. You can continue to carry on telephone conversations or send other fax transmissions during this time.



Deleting a Job

To terminate the polling readiness, simply delete the document from the jobs list (see also chapter *Jobs*, page 45).

Jobs

All messages that have just been sent, that have been prepared for polling or that are to be sent or polled at a later time are present in the jobs list.

Jobs appear in the display one-at-a-time. After the job number and job status indicator, you will find the fax number to which a fax is to be sent or from which it is to be polled. Documents on the jobs list can fall into the following categories with regard to their status:

T \overline{X} —Time-Deferred Sending

P \overline{Q} L—Time-delayed Fax Polling

T \overline{R} —Job in progress



Navigating in the Menu

Press \odot to close the menu and return to the starting mode.

Immediate Job Execution

1. Press **C**, **7** **1** and **OK**.
2. Using $\blacktriangle/\blacktriangledown$ select the job that you would like to execute immediately.
3. Confirm with **OK**. The transmission or polling will commence immediately.

Changing a Job

1. Press **C**, **7** **2** and **OK**.
2. Using $\blacktriangle/\blacktriangledown$ select the job that you would like to modify.
3. Confirm with **OK**.
4. Enter the desired changes and confirm by pressing **OK**.

Deleting a Job

1. Press **C**, **7** **3** and **OK**.
2. Using $\blacktriangle/\blacktriangledown$ select the job that you would like to delete.
3. Confirm with **OK**.
4. Confirm the deletion with **OK**.

Printing a Job

1. Press **C**, **7** **4** and **OK**.
2. Using $\blacktriangle/\blacktriangledown$ select the job that you would like to print out.
3. Confirm with **OK**.

Printing the Job List

Press **C**, **7** **5** and **OK**. The device will print out a list of all pending jobs.

12 Networks

EN

Using the USB cable, you can connect your device to a PC that is connected to a network. Other PCs on this network can then access the device if it is shared for use on the network. You cannot connect the device directly to a network with a USB cable, unless you have a USB print server connection.

A WLAN adapter enables you to connect the device to an existing network as a network printer. All computers in the network can then access the device and scan or print.



WLAN is Optional

WLAN is optional and functions only with an original adapter, which you can purchase through our order service. More information: www.philips.com



Calling the Web Interface

You can also edit the device's network settings with the device's web interface (see also chapter *Web Interface*, page 18).

Wireless Network (WLAN)



WLAN is Optional

WLAN is optional and functions only with an original adapter, which you can purchase through our order service. More information: www.philips.com

In a wireless network (Wireless Local Area Network, WLAN) at least two computers, printers or other additional devices communicate with each other over radio waves (high frequency waves). The transmission of data in the radio network is based on the standards 802.11b and 802.11g.

DANGER!



Information on Using WLAN!

The functioning of security systems, medical equipment or sensitive devices can be disrupted by the transmission power of the device. Observe any usage regulations (or restrictions) in the vicinity of such equipment.

The use of this device can affect the operation of insufficiently shielded medical devices and hearing aids and pacemakers through the release of high frequency radiation. Also consult a doctor or the manufacturer of the medical device to establish whether these are sufficiently shielded from external high frequency radiation.

Infrastructure Wireless Network

In an infrastructure network, multiple devices communicate via a central access point (gateway, router). All data are sent to the access point (gateway, router) and distributed from there.

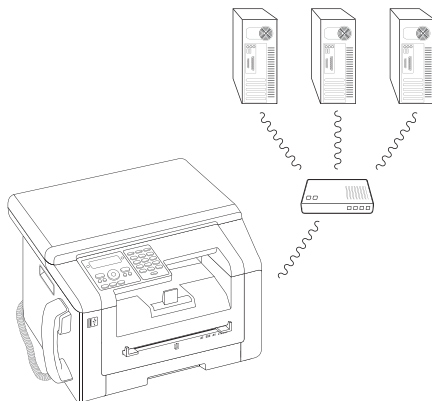

Setting Up a Wireless Network (WLAN)



Information on Configuration

We recommend that the settings of your WLAN network should only be changed by a person with a good knowledge of the configuration of your computer.

Three steps are required to integrate your device into a wireless network (WLAN).

1. Configure the network on your PC.
2. Configure your device for network operation.
3. Install the software **Companion Center SFX** on your computer using the required printer drivers.

You must carry out certain network and security settings (for example the Service Set ID (SSID) and the password). The settings must match the information for the network. The device guides you through setting up the network using a configuration wizard.

Connect WLAN Adapter

Insert the WLAN adapter into the USB host port on the reverse of the device.

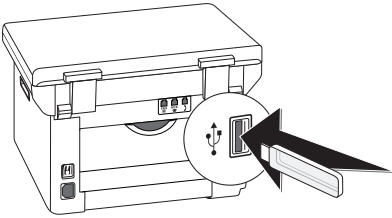

i WLAN is Optional

WLAN is optional and functions exclusively with an original adapter, which you can acquire from our order service (see Order Service on the back of this operating manual). Other wireless adapters can damage the device.

Switching Wireless Networking (WLAN) On/Off

Wireless networking is activated by default. You have the option of turning this function off.

1. Press **C**, **0** **8** **1** **0** and **OK**.
2. Use **▲/▼** to select whether you would like to turn the function on or off.
3. Confirm with **OK**.

Setting up a Wireless Network (WLAN) Using the Wizard

You can integrate your device very quickly and easily into an existing wireless network using Wi-Fi Protected Setup (WPS) or using a wireless network scan. Using WPS, all important settings like network name (SSID) are automatically configured and the connection protected with secure WPA Encryption.

Using Wi-Fi Protected Set-up (WPS)

Using Wi-Fi Protected Setup (WPS), you can integrate your device into an existing wireless network in two different ways very quickly and easily. You can activate the login with a pin code or using Push Button Configuration (PBC), if your access point (Access Point, Router) supports this method.

Using WPS with Pin Code

1. Press **C**, **0** **8** **1** **1** and **OK**.
2. Select with **▲/▼** **WPS PIN**.

3. A pin code appears on the display. Enter this pin code in your access point (Access Point, Router).
4. Press **OK** on the device. The WLAN access point and device connect automatically and create a WPA protected connection.

Using WPS with Push Button Configuration (PBC)

1. Press **C**, **0** **8** **1** **1** and **OK**.
2. Select with **▲/▼** **WPS PBC**.
3. Activate Push Button Configuration on the WLAN access point. The WLAN access point and device connect automatically and create a WPA protected connection.

Using Network Scan

Your device shows you a list of all available wireless networks. A wizard helps you connect with the desired wireless network.

1. Press **C**, **0** **8** **1** **2** and **OK**.
2. The available wireless networks are displayed. Use **▲/▼** to select the desired wireless network.
3. Confirm with **OK**.
4. Select an encryption standard or switch off network security using **▲/▼**.
5. Confirm with **OK**.
6. Enter the password for the network.

i WEP Key

With 64-bit encryption, the WEP key must be either 5 characters (ASCII) or 10 numbers (hexadecimal). With 128-bit encryption, the WEP key must be either 13 characters (ASCII) or 26 numbers (hexadecimal). You can find the WEP key in the network settings of your PC.

i WPA Key

Enter an 8 to 63 character long password. The password can contain alphanumerical characters—numbers and letters—and any other symbol available on the keypad. The only invalid character is "€" (the euro currency symbol).

7. Confirm with **OK**.
8. The device connects with the wireless network and automatically attempts to obtain an IP address.

Setting Up a Wireless Network (WLAN) Manually

The PC and all other devices must have their parameters set up to the same network as the multifunction machine. All required information for setting the parameters, like name of the network (SSID), type of wireless network, WEP key, IP address and subnet mask must match the data from the network. You can obtain the necessary information from the network configuration of your computer or the access point (Access Point, Router).

1. Press **C**, **0** **8** **2** **1** and **OK**.
2. Entering the SSID.

You can find the network name (Service Set ID) in the network settings of your computer. The SSID must match the SSID on the computer or on the access point (Access Point, Router).

3. Confirm with **OK**.
4. Select an encryption standard or switch off network security using **▲/▼**

CAUTION!



Unprotected Wireless Networks are Accessible to Others!

Unprotected Wireless Networks are Accessible to Others! Always protect your network against unauthorised access. You can toggle between different encryption standards.

5. Confirm with **OK**.
6. Enter the password for the network.



WEP Key

With 64-bit encryption, the WEP key must be either 5 characters (ASCII) or 10 numbers (hexadecimal). With 128-bit encryption, the WEP key must be either 13 characters (ASCII) or 26 numbers (hexadecimal). You can find the WEP key in the network settings of your PC.



WPA Key

Enter an 8 to 63 character long password. The password can contain alphanumerical characters—numbers and letters—and any other symbol available on the keypad. The only invalid character is "€" (the euro currency symbol).

7. Confirm with **OK**.

With the connection mode, you set the IP address and subnet mask. If you have a DHCP or BOOTP server in your network which dynamically assign IP addresses, you can assign the settings automatically.

8. Select automatic or manual configuration using **▲/▼**.
9. Confirm with **OK**.



This Process May Take a Few Moments.

The automatic configuration of IP address and subnet mask on the connected network PCs may take a moment.

10. **Manual Configuration:** Enter the IP address (for example 192.168.001.x××).



IP-Address

The first three blocks of numbers refer to the IP field; this information must match the IP address on your computer. The last three digits determine the individual IP address of the device. You can enter any number between 000 and 255. However, this number must be unique within the network; it may not be used on any other PC or network component.

11. Confirm with **OK**.
12. **Manual Configuration:** Enter the subnet mask (for example 255.255.255.000).



Subnet Mask

In a network with a gateway or router, the subnet mask indicates whether the respective data packets are addressed to an internal recipient in the network or whether they should be sent to a recipient outside of the network.

13. Confirm with **OK**.

Modifying Wireless Network Settings

Entering the Network Name (SSID)

You can find the network name (Service Set ID) in the network settings of your computer. The SSID must match the SSID on the computer or on the access point (Access Point, Router).

1. Press **C**, **0** **8** **2** **1** and **OK**.
2. Entering the SSID.
3. Confirm with **OK**.

Setting Network Security

CAUTION!



Unprotected Wireless Networks are Accessible to Others!

Unprotected Wireless Networks are Accessible to Others! Always protect your network against unauthorised access. You can toggle between different encryption standards.

1. Press **C**, **0** **8** **2** **2** and **OK**.
2. Select an encryption standard or switch off network security using **▲/▼**
3. Confirm with **OK**.

4. Enter the password for the network.



WEP Key

With 64-bit encryption, the WEP key must be either 5 characters (ASCII) or 10 numbers (hexadecimal). With 128-bit encryption, the WEP key must be either 13 characters (ASCII) or 26 numbers (hexadecimal). You can find the WEP key in the network settings of your PC.



WPA Key

Enter an 8 to 63 character long password. The password can contain alphanumerical characters—numbers and letters—and any other symbol available on the keypad. The only invalid character is “€” (the euro currency symbol).

5. Confirm with **OK**.

Set IP Address Assignment

The IP address assignment allows you to select whether your device's IP address is assigned dynamically by a DHCP or BOOTP router/server or statically assigned by the user. You can enter IP addresses, subnet masks, gateways or two alternative domain name servers (DNS) for the configuration of the static network connection.

1. Press **C**, **0****8****3** and **OK**.
2. Select automatic or manual configuration using **▲/▼**.
3. Confirm with **OK**.



This Process May Take a Few Moments.

The automatic configuration of IP address and subnet mask on the connected network PCs may take a moment.

Set Static IP Address Assignment



Available Function

This function is only available if you have selected static IP address assignment with the function **0****8****3**.

Enter IP Address

The IP address is the address of the device in the network. It must not match the IP address of the computer or other network components, however it must be located in the IP field.

1. Press **C**, **0****8****4****1** and **OK**.
2. Enter the IP address (for example 192.168.001.xxx).



IP-Address

The first three blocks of numbers refer to the IP field; this information must match the IP address on your computer. The last three digits determine are the individual IP address of the device. You can enter any number between 000 and 255. However, this number must be unique within the network; it may not be used on any other PC or network component.

3. Confirm with **OK**.

Entering the Subnet Mask

In a network with a gateway or router, the subnet mask indicates whether the respective data packets are addressed to an internal recipient in the network or whether they should be sent to a recipient outside of the network.

1. Press **C**, **0****8****4****2** and **OK**.
2. Enter the subnet mask (for example 255.255.255.000).
3. Confirm with **OK**.

Enter IP Address of the Access Point (= Gateway)

1. Press **C**, **0****8****4****3** and **OK**.
2. Enter the IP address of the access point (Access Point, Router).
3. Confirm with **OK**.

Enter Domain Name Server (DNS)

The DNS translates IP addresses in the names of internet pages and vice-versa. You can enter a primary and secondary DNS.

Enter Primary DNS

1. Press **C**, **0****8****4****4** and **OK**.
2. Enter the address of the primary DNS.
3. Confirm with **OK**.

Enter Secondary DNS

1. Press **C**, **0****8****4****5** and **OK**.
2. Enter the address of the secondary DNS.
3. Confirm with **OK**.

Verify DHCP Settings



Available Function

This function is only available if you have selected automatic IP address assignment with the function **0****8****3**.

With these functions, you can verify the assigned network settings from your network's DHCP router. You cannot modify the settings.

Displaying the IP Address

1. Press **C**, **0****8****5****1** and **OK**.
2. The current IP address is displayed; it is the address that your device is registered with on the network.

Display Subnet Mask

1. Press **C**, **0****8****5****2** and **OK**.
2. The subnet mask being used is displayed.

Display IP Address of the Access Point (= Gateway)

1. Press **C**, **0****8****5****3** and **OK**.
2. The IP address of the access point (router) is displayed.

Display Primary DNS

1. Press **C**, **0** **8** **5** **4** and **OK**.
2. The primary DNS address is displayed

Display Secondary DNS

1. Press **C**, **0** **8** **5** **5** and **OK**.
2. The secondary DNS address is displayed

Additional Wireless Network Settings

Enter the Primary Windows Internet Name Service (WINS) Server

WINS is a network service that converts the IP address of the connected network components into NetBIOS names and vice-versa on the local area network (LAN). You can enter a primary and secondary WINS server.

1. Press **C**, **0** **8** **6** **1** and **OK**.
2. Enter the address of the primary WINS server.
3. Confirm with **OK**.

Enter the Secondary Windows Internet Name Service (WINS) Server

1. Press **C**, **0** **8** **6** **2** and **OK**.
2. Enter the address of the secondary WINS server.
3. Confirm with **OK**.

Enter the First Network Name (= NetBIOS)

The device is registered on the network with the NetBIOS name.

1. Press **C**, **0** **8** **6** **3** and **OK**.
2. Enter the first NetBIOS name.
3. Confirm with **OK**.

Enter the Second Network Name (= NetBIOS)

1. Press **C**, **0** **8** **6** **4** and **OK**.
2. Enter the second NetBIOS name.
3. Confirm with **OK**.

13 Settings



Modifying the Basic Settings

The changed settings are stored as new default settings. If you select a special function for a one-time process, take care to restore the default settings or factory settings after that.



Calling the Web Interface

You can also edit the device's settings with the device's web interface (see also chapter *Web Interface*, page 18).



Navigating in the Menu

You can move the cursor using $\blacktriangle/\blacktriangledown$. Press **C** to return to the previous menu level. Press \odot to close the menu and return to the starting mode.

Set Up Power Saving Function

You use this function to set after what period of time the device switches to power saving mode following the print job. Whenever you receive a fax or if you would like to print or make a copy, your device will automatically switch back from its energy saving mode to its operating mode.

1. Press **ECO**.
2. Select with $\blacktriangle/\blacktriangledown$ **POWER SAVE**.
3. Confirm with **OK**.



Access Function

You can also call the function by pressing **C**, $\boxed{0}\boxed{0}\boxed{2}\boxed{1}$ and **OK**.

4. Select the time (in minutes) after which the device should switch to power saving mode using $\blacktriangle/\blacktriangledown$. You can choose between: 0, 2, 10, 30 minutes (factory default: 2 minutes). Select \emptyset if the device should switch to the power saving function immediately after a print job.
5. Confirm with **OK**.

Set Up Toner Saving Function

You use this function to switch on the toner saving function. The print appears a little paler, thereby increasing the number of pages that you are able to print with one toner cartridge.

1. Press **ECO**.
2. Select with $\blacktriangle/\blacktriangledown$ **TONER SAVE**.
3. Confirm with **OK**.



Access Function

You can also call the function by pressing **C**, $\boxed{0}\boxed{0}\boxed{2}\boxed{2}$ and **OK**.

4. Use $\blacktriangle/\blacktriangledown$ to select whether you would like to turn the function on or off.
5. Confirm with **OK**.

Set Up Paper Saving Function

Using this function, switch on automatic Duplex printing for printing and copying in order to save paper. With Duplex printing, both sides of the paper are printed.

1. Press **ECO**.
2. Select with $\blacktriangle/\blacktriangledown$ **PAPER SAVE**.
3. Confirm with **OK**.



Access Function

You can also call the function by pressing **C**, $\boxed{0}\boxed{0}\boxed{2}\boxed{3}$ and **OK**.

4. Select one-sided print (Simplex) or double-sided print (Duplex) using $\blacktriangle/\blacktriangledown$.
5. Confirm with **OK**.

Selecting the Country

CAUTION!



Setting the Country Correctly!

You must set the country in which you are operating the device. Otherwise your device is not adapted to the telephone network. If your country is not included in the list, you must select a different setting and use the correct telephone cable for the country. Consult your retailer.

1. Press **C**, $\boxed{0}\boxed{3}\boxed{1}$ and **OK**.
2. Use $\blacktriangle/\blacktriangledown$ to select the country in which you are operating the device.
3. Confirm with **OK**.

Selecting the Language

1. Press **C**, $\boxed{0}\boxed{3}\boxed{3}$ and **OK**.
2. Use $\blacktriangle/\blacktriangledown$ to select the desired display language.
3. Confirm with **OK**.

Setting the Date and Time

Entering the Date and Time

1. Press **C**, $\boxed{0}\boxed{1}\boxed{1}$ and **OK**.
2. Enter the date (two digits for each field), for example $\boxed{3}\boxed{1}\boxed{0}\boxed{5}\boxed{2}\boxed{5}$ for May 31th, 2025.
3. Enter the time, e.g. $\boxed{1}\boxed{4}\boxed{0}\boxed{0}$ for 2 pm.
4. Confirm with **OK**.

Set the Time Zone

Coordinated Universal Time (UTC) is the current standardised universal time format used. Starting from Greenwich in London (Zero Meridian), the world is split into time zones. These time zones are indicated with a deviance from UTC (in hours) for instance UTC+1 for Central European Time (CET)

In countries with several time zones, you can select from preset time zones or enter the deviance of your time zone from UTC. In countries with one time zone, the setting is adjusted automatically if you set the country correctly (see also chapter *Selecting the Country*, page 51).

1. Press **C**, **0** **1** **2** and **OK**.
2. Use **▲/▼** to select the time zone in which you are operating the device.
3. **Enter the Deviance from UTC Manually:** Enter the deviance (in hours) using the numeric keypad, for example, **1** for UTC+1. The display shows the time zone editor.



Time Zone Editor

Press **▲/▼** to change the sign (+/-). You can also enter values under an hour, example, 0.15 (or 0.25) for a quarter of an hour, 0.30 (or 0.50) for half an hour or 0.45 (or 0.75) for three quarters of an hour.

4. Confirm with **OK**.



Automatic Changeover Between Summer Time/Winter Time

With setting the country and time zone, the automatic changeover between summer and winter time is switched on. The automatic changeover is switched off if you enter the deviance from UTC manually using the time zones editor

Set the Time Synchronization with SNTP Server

With the simple time network protocol (SNTP), you can synchronize the date and time of your device with a server in the network automatically.

Activating the Server Access

1. Press **C**, **0** **1** **0** **3** and **OK**.
2. Use **▲/▼** to select whether you would like to turn the function on or off.
3. Confirm with **OK**.

Enter the SNTP Server Address

1. Press **C**, **0** **1** **0** **1** and **OK**.
2. Enter the name of the SNTP server.



Enter the Server Address

This name can be in the form of an IP address, a DNS address or a NetBIOS name.

3. Confirm with **OK**.

Enter the SNTP Server Port

1. Press **C**, **0** **1** **0** **2** and **OK**.
2. Enter the server port number (default setting: 123).
3. Confirm with **OK**.

Entering Your Telephone Number and Name

Your name and number are added together with date, time and page number at the top edge of each fax transmission (= header).

Entering Name

1. Press **C**, **0** **2** **1** and **OK**.
2. Enter your name. You can enter characters using the numeric keys (see key labels). Enter special characters using **0**. Press the respective key several times until the desired character or special character appears on the display.



Navigating in the Editor

You can move the cursor using **▲/▼**. Use **C** to delete individual characters.

3. Confirm with **OK**.

Entering Number

1. Press **C**, **0** **2** **2** and **OK**.
2. Enter your number.
3. Confirm with **OK**.

Setting the Ring Tones

Selecting the Ring Tone

You can use this function to select the standard ring tone. You can assign a separate ring tones to the entries in the telephone book (see also chapter *Saving Entry*, page 36).

1. Press **C**, **0** **5** **4** and **OK**.
2. Select the desired ring tone using **▲/▼**.
3. Confirm with **OK**.

Adjust volume level

1. Press **C**, **0** **5** **5** and **OK**.
2. Select the desired volume level using **▲/▼**.
3. Confirm with **OK**.

Setting the Number of Rings



Fax Mode

This function is only available if you have set the fax mode as fax reception mode (see also chapter *Setting the Fax Reception Mode*, page 54).

You can use this function to set the number of rings for the fax reception mode. After the selected number of rings, the device switches to fax reception in the fax mode. To turn off the ring tone entirely, select 0 (see also chapter *Silent Fax Reception*, page 55).

1. Press **C**, **0** **4** **2** and **OK**.
2. Select the desired number of rings using Δ/∇ .
3. Confirm with **OK**.

Deactivating the Button Tones

Every key press is accompanied by a sound. You can switch off the key tones on your device.

1. Press **C**, **0** **0** **7** and **OK**.
2. Use Δ/∇ to select whether you would like to turn the function on or off.
3. Confirm with **OK**.

Configure Paper Settings



Modifying the Basic Settings

The changed settings are stored as new default settings. If you select a special function for a one-time process, take care to restore the default settings or factory settings after that.

Set Paper Weight

1. Press **C**, **2** **0** **1** and **OK**.
2. Using Δ/∇ select the weight of the inserted paper.
3. Confirm with **OK**.

Set Paper Source

You can insert normal printing paper or printed documents (forms) into the paper tray. You can insert special paper formats, envelopes, slides, sheets of labels or printed documents into the manual paper feed.

1. Press **C**, **2** **0** **2** and **OK**.
2. Using Δ/∇ select the paper source.
3. Confirm with **OK**.

Setting the Paper Format

1. Press **C**, **2** **0** **3** and **OK**.
2. Using Δ/∇ select whether you would like to configure the paper format for the paper tray or whether you would like to use the manual feed.
3. Confirm with **OK**.
4. Use Δ/∇ to select the desired paper format. Follow the specifications in the technical data.
5. Confirm with **OK**.

Set Resolution

Setting the Resolution for Scanning

1. Press **C**, **3** **0** **3** and **OK**.
2. Select the desired resolution using Δ/∇ :
 DRAFT<100>—Scanning with reduced resolution—for use on the Internet, for example
 TEXT B&W <300>—Black and white scan with high resolution for optical character recognition of text documents (OCR)
 PHOTO<200>—Scanning with higher resolution - for photographs, for example
 HQ<300>—Scanning with highest resolution
3. Confirm with **OK**.

Set Resolution for Fax Transmission

1. Press **C**, **4** **0** **1** **3** and **OK**.
2. Select the desired resolution using Δ/∇ :
 DEFAULT—For documents without special features
 FINE—For texts with small print or drawings
 SFINE—For documents with many details
 PHOTO—For photos
3. Confirm with **OK**.

Setting the Resolution for the Copier

1. Press **C**, **1** **0** **3** and **OK**.
2. Select the desired resolution using Δ/∇ :
 AUTO—Optimised adjustment for all types of documents
 TEXT—For texts with small print or drawings
 QUALITY—For documents with many details
 PHOTO—For the highest resolution
3. Confirm with **OK**.

Adjust contrast

Setting the Contrast for the Scanner

1. Press **C**, **3** **0** **4** and **OK**.
2. Set the desired contrast using Δ/∇ .
 -/1—Reduces the contrast / typeface appears lighter
 4 (Factory settings)—Optimized adaptation for all documents
 +/7—Increases the contrast / typeface appears darker (for example, documents with faint print)
3. Confirm with **OK**.

Set the Contrast for Faxes and Copying

1. Press **C**, **1** **0** **4** and **OK**.
2. Set the desired contrast using $\blacktriangle/\blacktriangledown$.
 - /1—Reduces the contrast / typeface appears lighter
 - 4 (Factory settings)—Optimized adaptation for all documents
 - +/?—Increases the contrast / typeface appears darker (for example, documents with faint print)
3. Confirm with **OK**.

Setting the Brightness

Set the Level of Brightness for Scanning

1. Press **C**, **3** **0** **5** and **OK**.
2. Using $\blacktriangle/\blacktriangledown$, select the desired level of brightness:
 - /1—Reproduction is lighter
 - 4 (Factory settings)—Optimized adaptation for all documents
 - +/?—Reproduction is darker
3. Confirm with **OK**.

Set the Level of Brightness for the Copier

1. Press **C**, **1** **0** **5** and **OK**.
2. Using $\blacktriangle/\blacktriangledown$, select the desired level of brightness:
 - /1—Reproduction is lighter
 - 4 (Factory settings)—Optimized adaptation for all documents
 - +/?—Reproduction is darker
3. Confirm with **OK**.

Additional Scanner Options

Setting the Paper Format

1. Press **C**, **3** **0** **6** and **OK**.
2. Use $\blacktriangle/\blacktriangledown$ to select the desired paper format. Follow the specifications in the technical data.
3. Confirm with **OK**.

Select the File Format

Using this function, select the file format that should be used as default for scanning documents.

1. Press **C**, **3** **0** **7** and **OK**.
2. Use $\blacktriangle/\blacktriangledown$ to select the desired file format.
3. Confirm with **OK**.

Additional Copier Options

Select One Side/Both Side Printing (Simplex/Duplex)

1. Press **C**, **1** **0** **1** and **OK**.
2. Select one-sided print (Simplex) or double-sided print (Duplex) using $\blacktriangle/\blacktriangledown$.
3. Confirm with **OK**.

Setting the Fax Reception Mode

The built-in fax switch of your device distinguishes between fax messages and telephone calls. Faxes are automatically received, telephone calls can be received—even on additionally connected devices. While the device is checking the call, it continues to ring.

You have the following options available. The selected fax reception mode appears on the display.

1. Press **C**, **0** **4** **1** and **OK**.
2. Select the desired option using $\blacktriangle/\blacktriangledown$.



Fax Reception Mode with Additional Devices

You should set the device to EXT/Answering device, Fax or Manual Mode if you have additional devices connected to the **AUX./** socket of your device.

3. Confirm with **OK**.

Manual Mode

(MANUAL)

The device will not receive faxes on its own. You can start fax reception manually, by pressing \blacklozenge . This setting is useful, when you want to receive faxes via a modem connected to a computer.

Fax Mode

(FAX)

In the fax mode, the device will ring for as many times as you have set with function 042 (see also chapter *Setting the Number of Rings*, page 53). Then the fax reception switches on. You should select this mode if you primarily receive faxes at your device.

EXT/Answering Machine Mode

(FAX-ANSWER)

You should set the device to this mode if you have additional devices connected to the **AUX./** socket of your device. If an additionally connected answering machine receives a call, your device will check to determine whether or not the incoming call is a fax transmission. If the device recognises a fax signal, it will automatically receive the fax transmission.

If you do not have an answering machine connected or if a connected answering machine does not accept the call, the device will take over the call after a predetermined number of rings and automatically receive any possible fax transmission being sent.



Fax at Additional Telephone

If you pick up at an additional device and hear that you are receiving a fax (whistling tone or silence), you can start the fax reception by pressing ***15** on the additional telephone or pressing **◇** on the device. To use this function, additional telephones must be set to the tone dialling mode (DTMF/MFV tones) (for this purpose see the operating manual of your additional telephone).

Automatic Mode

(AUTOMATIC)

If the Automatic Mode is active, the device will check to determine whether the incoming call is a fax transmission or a telephone call. The device will automatically receive fax transmissions. While the device is checking the call, it continues to ring. You can accept telephone calls at any time. After a predetermined number of rings, the device will take over the call and automatically receive a possible silent fax transmission.

Silent Fax Reception

Set the number of rings \boxtimes (see also chapter *Setting the Number of Rings*, page 53) and set the fax reception mode to fax mode (see also chapter *Setting the Fax Reception Mode*, page 54), in order to receive faxes without your device ringing.

Additional Options for Fax Transmission

Reducing Transmission Speed

The device adapts the transmission speed to the line quality. This may take some time, especially for overseas connections. Set a lower transmission speed if you are sending faxes into networks with poor line quality.

1. Press **C**, **4 0 1 5** and **OK**.
2. Select the desired speed using **▲/▼**.
3. Confirm with **OK**.

Configuring the Display

Configure which information should be shown on the display during transmission.

1. Press **C**, **4 0 1 6** and **OK**.
2. Use **▲/▼**, to select whether the transmission speed should be displayed or current page number being transmitted should be displayed.
3. Confirm with **OK**.

Set Fax Transmission from the Memory

You can set whether you would like to scan or send the documents immediately or whether you would like to send the documents from the cache memory. With direct transmission, the document is memorized during transmission. When sending from the memory, the document is read from the memory first and then the connection made with the recipient.



Message Memory Full

If the message memory is full, the documents are scanned and sent immediately.

1. Press **C**, **4 0 1 2** and **OK**.
2. Select the desired setting using **▲/▼**.
3. Confirm with **OK**.

Turning Page Header On/Off

Your name and number appear in the page header of each fax transmission. If you do not wish to send out your information, you can turn this function off.

1. Press **C**, **4 0 1 4** and **OK**.
2. Use **▲/▼** to select whether you would like to turn the function on or off.
3. Confirm with **OK**.

Switching Transmission Report On/Off

After every transmission, the device prints out a transmission report. Two different settings are available.

1. Press **C**, **4 0 1 1** and **OK**.
2. Use **▲/▼** to select from the following settings:
 - ALWAYS—The transmission report will be printed after each successful fax transfer as well as after interrupted transfers.
 - ON ERROR—The transmission will only be printed if the fax transfer was not successfully completed or if it was terminated prematurely.
3. Confirm with **OK**.

Additional Fax Reception Options

Switches Time Stamp On/Off

The device prints the date and the exact arrival time on every incoming fax received (see also chapter *Time Stamp*, page 44). You have the option of turning this function off.

1. Press **C**, **4 0 4** and **OK**.
2. Use **▲/▼** to select whether you would like to turn the function on or off.
3. Confirm with **OK**.

Reducing the Reception Speed

The device adjusts the transmission speed to the line quality. Set a lower reception speed if this adjustment takes a long time or no connection is made.

1. Press **C**, **4****0****2****6** and **OK**.
2. Select a reception speed using **▲/▼**.
3. Confirm with **OK**.

Set Page Adjustment

Received faxes can automatically be adjusted to the paper format inserted. You can also enter a fixed value (percentage) for the paper adjustment

Setting the Paper Format

For automatic adjustment, the format of the inserted paper must be set correctly (see also chapter *Setting the Paper Format*, page 53).

1. Press **C**, **4****0****2****4** and **OK**.
2. Use **▲/▼** to select automatic adjustment or whether you would like to enter a fixed value.
3. Confirm with **OK**.
4. **Enter a Fixed Value:** Enter a percentage for the compression between **7****0** and **1****0****0** percent.
5. Confirm with **OK**.

Set a Threshold for Pagination

Some fax transmissions contain more lines than can be printed. Using the threshold for pagination, set from which value these lines are printed on the second page. All lines below this value are deleted.

1. Press **C**, **4****0****2****7** and **OK**.
2. Use **▲/▼** to select from the following settings:
 - ON—All lines which lie more than three centimetres outside the page are printed on a second page. All surplus lines below this value are deleted.
 - OFF—All lines which lie more than one centimetre outside the page are printed on a second page. All surplus lines below this value are deleted.
3. Confirm with **OK**.

Printing Multiple Copies

You can apply settings to your device whereby multiple copies of fax transmissions are printed out upon reception.

1. Press **C**, **4****0****2****2** and **OK**.
2. Enter a value from **1** to **9****9**.
3. Confirm with **OK**.

Locking the Device

With the locking function, you can prevent unauthorised persons from using your device. Only after entering of the correct code will it be possible to access functions or enter numbers. The lock will turn itself on again after each use of the device.

Entering the PIN Code

Default Access Code

The function is switched off with the factory-installed access code (0000). Change the access code to switch on the function. If you want to switch the function off enter the factory-installed code 0000 again.

1. Press **C**, **9****2****1** and **OK**.

Entering the PIN Code

If you have already saved a code, the device will ask you to provide the old code first before you can enter a new code.

2. Enter a four-digit PIN code.
3. Confirm with **OK**.
4. Enter the code again for confirmation purposes.
5. Confirm with **OK**.

Locking the Keyboard

This function locks the entire keyboard of the device.

1. Press **C**, **9****2****2** and **OK**.
2. Enter the four-digit PIN code.
3. Confirm with **OK**.
4. Use **▲/▼** to select whether you would like to turn the function on or off.
5. Confirm with **OK**.

Locking Manual Dialling

This function blocks the manual dialling of telephone numbers. Numbers from the telephone book can be called. Manual dialling of emergency number is **not** possible.

1. Press **C**, **9****2****3** and **OK**.
2. Enter the four-digit PIN code.
3. Confirm with **OK**.
4. Select with **▲/▼** ONLY DIRECT..
5. Confirm with **OK**.

Lock USB Storage Medium

You use this function to block access to a connected USB storage medium.

1. Press **C**, **9****2****5** and **OK**.
2. Enter the four-digit PIN code.
3. Confirm with **OK**.
4. Use **▲/▼** to select whether you would like to turn the function on or off.
5. Confirm with **OK**.

Lock Settings

This function blocks the changing of settings on your device. The settings can be locked with a customizable administrator pin code

Entering the PIN Code



Default Access Code

The function is switched off with the factory-installed access code (0000). Change the access code to switch on the function. If you want to switch the function off enter the factory-installed code 0000 again.

1. Press **C**, **0** **0** **0** **0** **1** and **OK**.



Entering the PIN Code

If you have already saved a code, the device will ask you to provide the old code first before you can enter a new code.

2. Enter a four-digit PIN code.
3. Confirm with **OK**.
4. Enter the code again for confirmation purposes.
5. Confirm with **OK**.

Activate and deactivate functions

1. Press **C**, **0** **0** **0** **0** **2** and **OK**.
2. Enter the four-digit PIN code.
3. Confirm with **OK**.
4. Use **▲/▼** to select whether you would like to turn the function on or off.
5. Confirm with **OK**.

Print Lists and Reports

Printing the Functions List

Press **C**, **8** **1** and **OK** to print a list of all functions of your device.

Printing the Telephone Book

Press **C**, **8** **3** and **OK** to print a list of all saved entries and groups in the telephone book.

Printing Fax Journal

The journal contains a list of the last 30 message transmissions. The fax journal is automatically printed after 30 transmissions. You can print out the fax journal at any time.

Press **C**, **8** **2** and **OK**.

Printing the Job List

Press **C**, **8** **4** and **OK**. The device will print out a list of all pending jobs.

Prints the List of Settings

Press **C**, **8** **0** and **OK** to print a list of all settings of your device.

14 Telephone Lines and Additional Devices

EN

Switching Caller Line Identification (CLIP) On/Off

(Function is not supported in all countries and networks)

The number of an incoming call appears on the display. For this function to work, the Calling Line Identification Presentation (CLIP) must be activated for your telephone line. Enquire with your telephone company. Caller Line Identification may be associated with a fee.



Setting the Country Correctly

If the Caller Line Identification does not work even though the function is activated for your telephone line, check if you have set the correct country (see also chapter *Selecting the Country*, page 51).

1. Press **C**, **0** **5** **7** and **OK**.
2. Use **▲/▼** to select whether you would like to turn the function on or off.
3. Confirm with **OK**.

Selecting the Dialling Process

(Function is not supported in all countries and networks)

In some countries you can set the dialling mode to pulse dialling or tone dialling (DTMF tones).



Selecting the Dialling Process

Only use pulse dialling if tone dialling is not yet activated for your telephone line.

1. Press **C**, **0** **5** **3** and **OK**.
2. Use **▲/▼** to select the desired dialling process.
3. Confirm with **OK**.

Set up the Public Switch Telephone Network (PSTN)

(Function is not supported in all countries and networks)



Public Switch Telephone Network (PSTN)

You can use this function to set your device to connect to the Public Switch Telephone Network (PSTN) (see also chapter *Set up Private Branch Exchange (PABX)*, page 58).

Your device is automatically adjusted to the telephone network if you set the country correctly (see also chapter *Selecting the Country*, page 51). It is possible that further settings are required for the Public Switched Telephone Network (PSTN). Ask your retailer or the technical customer service department.

1. Press **C**, **0** **3** **2** and **OK**.
2. Select the desired setting using **▲/▼**.
3. Confirm with **OK**.

Enter the dialing code

You can enter a dialing code for the connection to a telecommunications provider or a network, for example. This number will be placed automatically before every number that you dial.

1. Press **C**, **0** **5** **2** **2** and **OK**.
2. Enter the telephone number. This number will be placed automatically before every number that you dial.
3. Confirm with **OK**.

Set up Private Branch Exchange (PABX)

Private branch exchanges (PABX) are typical in many offices and some households. You must dial an outside line access code in order to get a connection to the public telephone network (PSTN) from a PABX.



Additional Telephone No Extension

An additional telephone connected to the device on a telephone socket is not considered an extension.

You can set up your device for operation on an extension, indicate the length of the internal numbers (direct dial number) and save the code which must be selected in order to reach the Public Switched Telephone Network (PSTN) (= outside line access code).



Outside Line Access Code is Automatically Dialed

Once these settings are in place, you will no longer need to prefix the outside line access code every time you enter an external number. The device will automatically add the outside line access code in front of numbers that are the same length or longer than the configured direct dial numbers.

Set the connection type

1. Press **C**, **0** **5** **1** and **OK**.
2. Use **▲/▼** to set whether you operate your device on an extension.
3. Confirm with **OK**.

Setting the Outside Line Access Code

Enter the length of the direct dial number

1. Press **C**, **0** **5** **2** **1** and **OK**.
2. Enter the appropriate length for internal numbers. Use **C** to delete individual characters. Assume the longest internal number, then add one digit to that. If your direct dial numbers consist of four digits, then you should input **5**.
3. Confirm with **OK**.

Enter the outside line access code

1. Press **C**, **0** **5** **2** **2** and **OK**.
2. Enter the outside line access code with which you reach the public telephone network. This is usually **0**.



Incorrect Outside Line Access Code

In rare cases, the outside line access code may be a different number or a two-digit number. For older telephone systems, the outside line access code can be R (= Flash). Press **R** to enter this outside line access code. If the connection to the public telephone network is not possible, contact your telephone system supplier.

3. Confirm with **OK**.

DSL Connection

In the event that you use a DSL modem: Connect the device to the slot intended for analogue telephones/fax machines! For additional information, please consult the operating manual of your DSL system. Ask your telephone or internet service provider if necessary.

ISDN Connection

Your device is an analogue fax device (Group 3). It is not an ISDN device (Group 4), and therefore it cannot be operated directly on an ISDN connection. In order to do this, you need either an analogue adapter or a connection for analogue terminals. Details for ISDN connections can be found in the instructions provided with the terminal adapter or the dial-up router.

Registering and De-Registering Additional Cordless Telephones

(Function is optional and functions only with an original adapter, which you can purchase through our order service. More information: support.service@sagem-com.com)

Normally your cordless telephone is registered with your device in the factory. In the starting mode, press **OK**. The display shows on which base unit and with which number the cordless telephone is registered.

You can register in all up to 4 cordless telephones with your device. Using only original cordless phones as additional cordless phones ensures optimum use of all functions. You can get original cordless telephones through our order service or at specialist shops.



GAP Compatible

Additional cordless telephone must be GAP-compatible.

Registering Cordless Telephone

You must first bring the cordless telephone and then your device (= base station) in the registration mode to register a cordless telephone. Follow the instructions in the operating instructions of the cordless telephone.

1. Insert the Dect adapter into the USB host port on the reverse of the device.

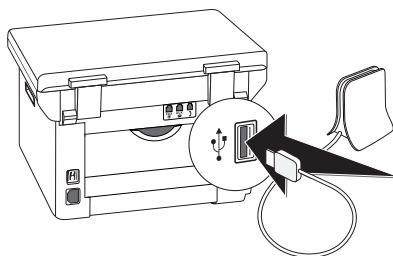

2. A message appears on the display as soon as the device is configured as base unit. Bring the cordless telephone into registration mode.
3. Press **C**, **5** **2** **1** and **OK** on the device.

The cordless telephone is automatically registered. This process can take a few minutes. Then the number with which it is registered with the device appears on the display of the cordless telephone.



Registering other Cordless Telephones

You can register other cordless telephones with your device in the same manner. If you face any difficulties in registering, de-register all cordless telephones, and re-register them individually.



Display Date and Time

Date and time of the cordless telephone is continually synchronised with the device.

Deregistering Cordless Telephone

You can deregister a cordless telephone either from the device or from the cordless telephone. Follow the instructions in the operating instructions of the cordless telephone.

1. Press **C**, **5** **2** **2** and **OK**.
2. Using **▲/▼** to select which cordless telephone you would like to de-register.
3. Confirm with **OK**. The device disconnects from the cordless telephone.

Looking for Cordless Telephone

This function helps you in locating cordless telephones, which you have misplaced. For this purpose the cordless telephones must be registered with the device and must be within its range.

1. Press **C**, **5** **2** **3** and **OK**.
2. All cordless telephones registered with the device ring for approx. one minute. You can end the search function by pressing **Ⓜ** on the device or pressing the button to hang up on the cordless telephone.

Connecting Additional Devices

You can operate additional devices on a telephone line, such as cordless telephones, answering machines, modems or charge counters.

Connection to the Device

You can connect additional devices directly to your device. Insert the telephone cable of the additional device into the **AUX./** socket (RJ-11-connection) on the device.

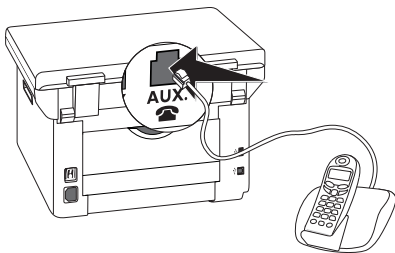

Connection to the Telephone Line

In order for the fax switch to function, the device must be first in the series if multiple devices are connected to the same telephone socket. Follow the correct order.

i Connection to the First Telephone Socket

If you have multiple telephone sockets for the same telephone line, the device must be connected to the first telephone socket.

Using Additional Telephones (Easylink)

With the Easylink function you can control your device with additional telephones. To use this function, additional telephones must be set to the tone dialling mode (DTMF/MFV tones) (for this purpose see the operating manual of your additional telephone).

Starting Fax Reception

If you pick up at an additional device and hear that you are receiving a fax (whistling tone or silence), you can start the fax reception by pressing ***5** on the additional telephone or pressing **◇** on the device.

Hang up the additional telephone when the ring tone changes. The device has accepted the reception of the fax message.

Taking Over the Line

If you pick up on an additional telephone and the device continues to ring or attempts to receive a fax, you can disconnect the device from the line. Press ****** on the additional telephone.

Using an External Answering Machine

Your external answering machine must have parallel recognition for accepting incoming calls. Consult your retailer.

For the best operation, the answering machine must be connected to the **AUX./** socket of the device. Select EXT/ answering machine mode as the fax reception mode (see also chapter *Setting the Fax Reception Mode*, page 54).

i Length of Outgoing Message

The outgoing message must be shorter than ten seconds. Avoid music in your announcement. If the external answering machine has a "conserving function" (i.e. a function that changes the number of rings as soon as new messages have been recorded), switch it off.

i Answering Machine Records Fax Signals

If the external answering machine records fax signals, but your device cannot receive faxes, inspect the connection of the external answering machine

15 Service



Troubleshooting

Should disruptions occur, follow the instructions on the display and on the error report.



Calling the Web Interface

The device's web interface also provides an overview of the device status and various service functions (see also chapter *Web Interface*, page 18).

Access Help Pages

With the **Companion Center SFX** software, you can display the device's operating instructions, access service pages on the Internet and order replacement items.

1. Click on **Help**.

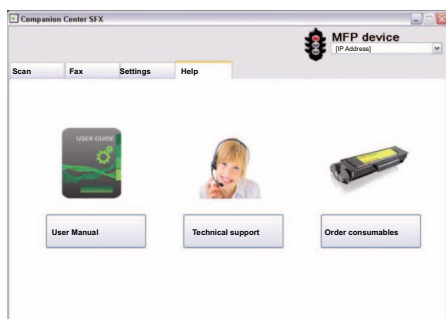

2. Select the desired function.

Display Counter Levels

You can display different counter levels of the device for your information.

Display the Number of Fax Pages Sent

Press **C**, **9** **4** **1** and **OK**. The number of fax pages sent is shown

Display the Number of Fax Pages Received

Press **C**, **9** **4** **2** and **OK**. The number of fax pages received is shown

Display Number of Scanned Documents

Press **C**, **9** **4** **3** and **OK**. The number of scanned documents is displayed.

Display Number of Printed Pages

Press **C**, **9** **4** **4** and **OK**. The number of printed pages is displayed.

Display Number of Copied Pages

Press **C**, **9** **4** **5** and **OK**. The number of copied pages is displayed.

Displaying the Toner Level

Your device registers the extent of toner used for every print-out and calculates the toner level of the toner cartridge on that basis. The toner level is stored in each toner cartridge.

Press **C**, **9** **4** **6** and **OK**. The toner level of the toner cartridge is indicated by a percentile value between 100 percent (full) and 0 percent (empty).

Checking the Firmware Version

1. Press **C**, **9** **3** **4** and twice **OK**.
2. The information on the firmware version of the device is displayed.
3. Confirm with **OK**.

Updating Firmware



Calling the Web Interface

You can also edit the device firmware with the device's web interface (see also chapter *Web Interface*, page 18).

The firmware defines the basic functions and capabilities of your device. Sometimes also referred to as the device driver. We constantly strive to implement improvements and innovations. Check our homepage www.philips.com for information on the current firmware version available for your device.

CAUTION!



Do not interrupt power supply

Do not switch the device off during the print process and do not unplug the device from the power supply. If the Firmware update is not carried out error-free, your device will probably no longer function properly.

Wait until the firmware update is completed before performing more operations on your device.

CAUTION!



Settings will be Deleted

Depending on the firmware version of your device, all modified settings are deleted during a firmware update and reset to factory settings. If the settings are deleted, you will need to calibrate the scanner again (see also chapter *Calibrating the Scanner*, page 67).

1. Load the firmware from the specified internet page and save the file directly in the root directory of the USB storage medium (= highest directory level). The file shall not be saved in a folder.

CAUTION!



Use Only Original Firmware

When carrying out a Firmware update only use the Firmware file for your device from the website: www.philips.com. Using other Firmware files can lead to your device not functioning properly. Sagemcom accepts no liability for device malfunctions which can be traced back to the use of third party Firmware.

2. Connect the USB storage medium with the firmware file to the USB host connection port.

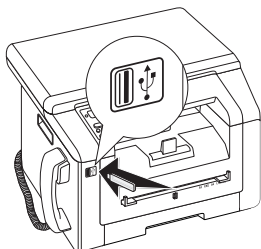

3. If the device detects the firmware file, a message appears on the display. Press \diamond to update firmware.
4. This process can take a few minutes. The device re-boots twice. On completion of the procedure, the device starts the initial installation process (see also chapter *Initial Installation*, page 15).

CAUTION!



Removing USB Storage Media!

Never pull out the storage medium while the device is accessing it. If the Firmware update is not carried out error-free, your device will probably no longer function properly.

Changing the Toner Cartridge

Your device registers the extent of toner used for every print-out and calculates the toner level of the toner cartridge on that basis. The toner level is stored in each toner cartridge. You can use different toner cartridges as well as display the respective toner level of the toner cartridge.

DANGER!



Escaping Toner Dust!

Never open a toner cartridge. If toner dust is released into the air, you should avoid allowing it to contact your skin and eyes. Do not inhale the released toner dust. Remove the toner dust from clothing or objects with cold water; hot water would only cause the toner to set. Never remove loose toner dust with a vacuum cleaner.

CAUTION!



Use Original Consumable Materials!

Use only original consumable materials. These are available from a specialised retailer or through our order service. Other consumable materials can cause damage to the device.

CAUTION!



Observe Packaging Instructions

Follow the instructions on the packaging of the consumable materials.

1. Open the upper device cover by gripping the cover on the arrow marks on the outside and lift upwards,

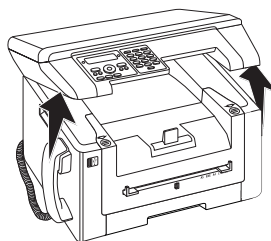

2. Open the device by lifting the device cover forwards

CAUTION!



Do Not Open During a Print Job!

Never open the cover while the device is printing.

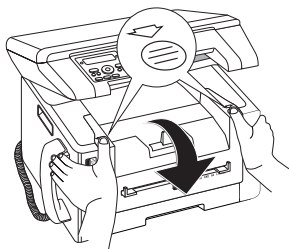

3. Remove the toner cartridge by gripping the handle in the middle and pulling it forwards out of the device

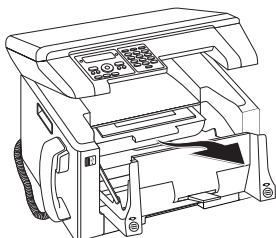

DANGER!



Escaping Toner Dust!

Carefully remove the toner cartridge from the device so that no toner dust spills out. Take care where you place the toner cartridge, escaping toner dust may soil the surface.

Store opened or used toner cartridges in their original packing or in a plastic bag in order to prevent toner dust from escaping. Dispose of old toner cartridges by turning them in at specialised shops or at a waste collection site. Never dispose of toner cartridges by throwing them into fire. Toner cartridges should never be allowed into the hands of children.

4. Take the new toner cartridge from the package.
5. Remove the tape and protective paper, **but do not remove the protective strip from the cartridge yet.**

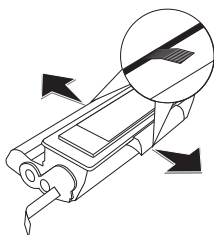

6. Shake the new toner cartridge back and forth several times in order to distribute the toner evenly, thereby improving the print quality.

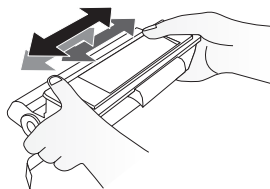

7. **Only after** completely pull off the protection strip located on the left side of the cartridge.

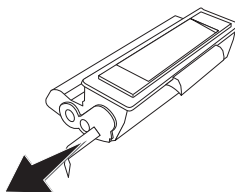

DANGER!



Escaping Toner Dust!

Once you have removed the protection strip, do not shake the toner cartridge any more. Otherwise, it is possible that toner dust will be released into the air.

8. Place the toner cartridge into your device. The cartridge should snap securely into position.

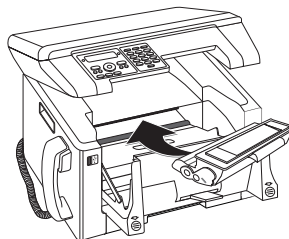

9. Close the device.

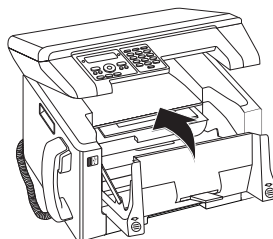

CAUTION!



Toner Cartridge Not Inserted Correctly!

If the device cover would not close, the toner cartridge is not inserted correctly. Take the toner cartridge out and insert it again correctly.

10. Close the upper device cover.

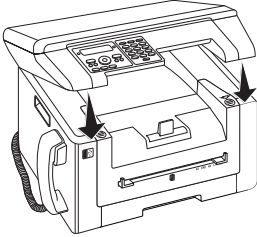

Fixing a Paper Jam

Your device is equipped with sensors that quickly recognises a paper jam. If trouble of this sort arises, the feeding of the printer paper is stopped immediately. Check **all** the following three areas for jammed paper: Paper tray/paper feed, print unit and fuser unit (see also the help below).

DANGER!



Escaping Toner Dust!

In case of a paper jam, do not forcefully remove the paper; but rather pull it gently out of the device and throw it away carefully. It is possible that the toner may not be completely set on the print-out, and toner dust could be released into the air. Do not inhale the released toner dust. Remove the toner dust from clothing or objects with cold water; hot water would only cause the toner to set. Never remove loose toner dust with a vacuum cleaner.

Clearing Paper Jam in Paper Tray/ Paper Feed

1. Pull the paper tray out of the device.

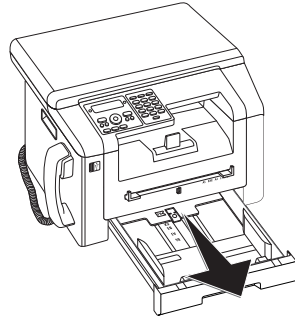

2. Carefully pull out the paper.

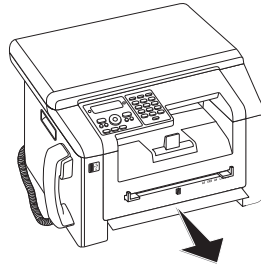

3. Push the paper tray into the device all the way to the stopping point.

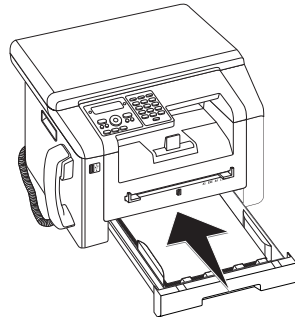

Clearing Paper Jam in the Print Unit

1. Open the upper device cover by gripping the cover on the arrow marks on the outside and lift upwards,

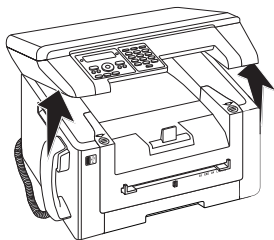

2. Open the device by lifting the device cover forwards

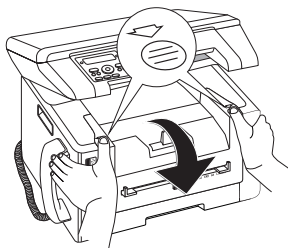

3. Remove the toner cartridge by gripping the handle in the middle and pulling it forwards out of the device

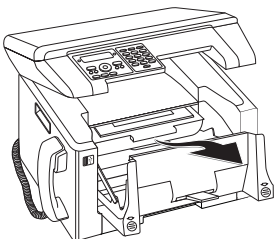

DANGER! Escaping Toner Dust!

Carefully remove the toner cartridge from the device so that no toner dust spills out. Take care where you place the toner cartridge, escaping toner dust may soil the surface.

Never open a toner cartridge. If toner dust is released into the air, you should avoid allowing it to contact your skin and eyes. Do not inhale the released toner dust. Remove the toner dust from clothing or objects with cold water; hot water would only cause the toner to set. Never remove loose toner dust with a vacuum cleaner.

4. Open the paper jam flap.

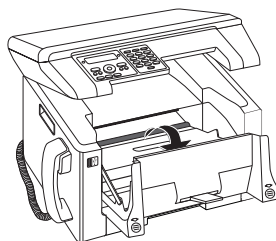

5. Carefully pull out the paper.

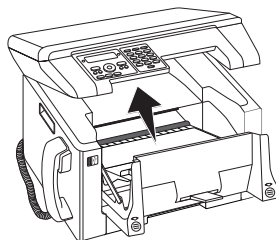

6. Close the paper jam flap.

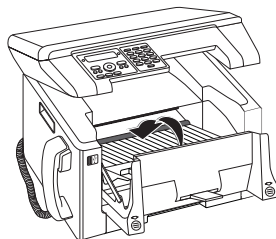

7. Place the toner cartridge into your device. The cartridge should snap securely into position.

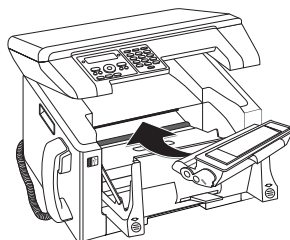

8. Close the device.

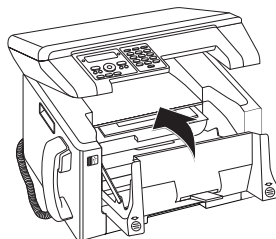

CAUTION!



Toner Cartridge Not Inserted Correctly!

If the device cover would not close, the toner cartridge is not inserted correctly. Take the toner cartridge out and insert it again correctly.

9. Close the upper device cover.

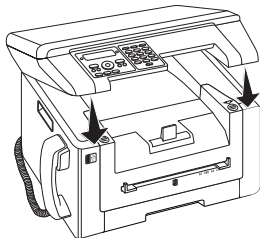

Fixing Paper Jam in the Duplex Unit/Fuser Unit

1. Open the paper jam flap on the reverse side of the device.

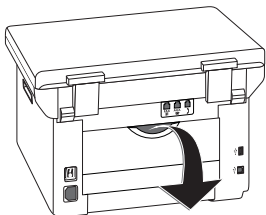

DANGER—HEAT!



Device Parts are Hot!

The fuser unit and its surroundings inside the device become hot during operation. Do not touch these parts if you have opened the device. Proceed with care when you are removing a paper jam for instance.

2. Remove the paper guide on the fixer unit by pressing the tension lever **on both sides** downwards.

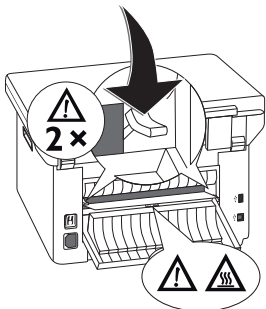

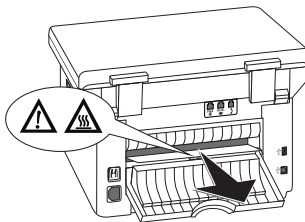

3. Carefully pull out the paper.

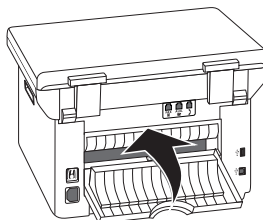

4. Close the paper jam flap. The fuser levers will automatically fold into starting position when the paper jam cover is closed.



Continue Print Job

Press  after the problem has been rectified to continue the print job. Press  to suppress the error message.

Cleaning

If lines appear on the printed pages or on the fax transmissions or documents are not properly fed, you should clean the scanner.

Switch the device off and disconnect from the power supply before you clean it.

CAUTION!



Switching off the device!

Turn the device off using the on/off switch on the back before you remove the plug from the socket.

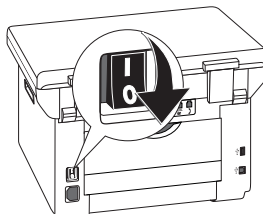

CAUTION!



Recommissioning!

Plug the power cable into the electrical outlet. **Only after** switch the device on using the on/off switch on the rear.

DANGER!



Instructions for Cleaning!

Use a soft, lint-free cloth. Never use liquid or easily flammable cleansers (sprays, abrasives, polishes, alcohol, etc.). Do not allow any moisture to reach the interior of the device.

Moisten the cloth **slightly** with cleaning alcohol in order to remove stubborn marks. The cloth must however, **never** be wet.

Cleaning the Scanner

1. Open the scanner cover.

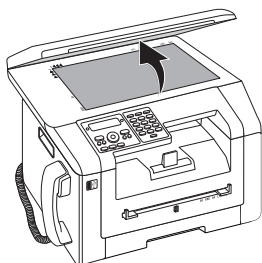

2. Carefully wipe the scanner glass of the flatbed scanner with a lint-free cloth.

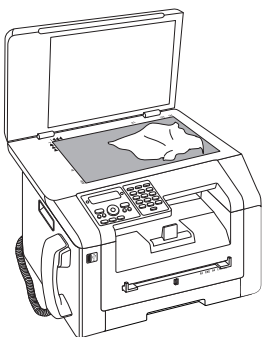

3. Close the scanner cover.

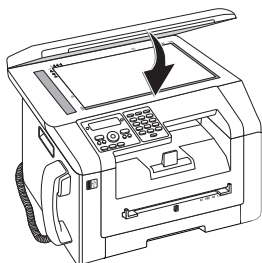

Calibrating the Scanner

If vertical lines appear on the printed pages or on the fax messages, it is possible the scanner needs to be calibrated.

CAUTION!



Instructions for Calibrating!

The scanner is calibrated in the factory and normally no new calibration is needed. Clean the scanner glass and the scanner film first before calibrating the scanner (see also chapter *Cleaning*, page 66).

1. Insert a white piece of paper onto the flatbed scanner.

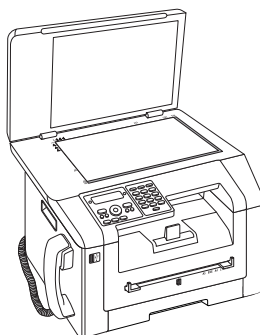

2. Press **C**, **9** **3** **1** and **OK**.
3. Confirm with **OK**.
4. Wait until calibration is completed and the device returns to starting mode.

Using Service Codes

The service codes delete all the changed settings and your device is reset to factory settings. It may be possible that the device with the changed settings reacts differently than expected.

CAUTION!



Settings will be Deleted!

Only use the service codes if this is absolutely necessary. Some service codes also delete saved messages and telephone book entries.

1. Press **C**, **9** **3** **3** and **OK**.
2. Enter a service code:
 - 7** **0** **0** **1** **5**—Deletes all changed settings. Saved data and telephone book entries remain intact.
 - 7** **0** **0** **2** **6**—Deletes all queued print jobs, when there are problems with printing.
 - 7** **0** **1** **5** **8**—Deletes all changed settings and saved data. The device is reset to factory settings and the initial installation process is started.
3. Confirm with **OK**.

4. Select with ▲/▼ YES.
5. Confirm with **OK**.



Cancelling Entry

If you have entered the incorrect code, you can cancel the entry with **NO**.

Power Cycling

If a problem occurs that cannot be corrected with the instructions in this user manual (see also the help below), follow the steps given here.

1. Switch the device off using the on/off switch on the rear.

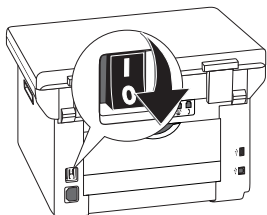

2. Wait at least ten seconds.
3. Switch the device on using the on/off switch on the rear.

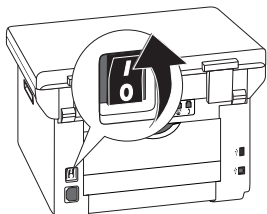



4. Follow the instructions on the display. If the problem repeats, please contact our technical customer service or your retailer.

Problems and Possible Causes



General Information	Possible Cause(s)
The time and date flash on the display.	You must check the time and date after a short power failure. Confirm with OK .
No fax transmission	<p>Check the installation of the device. Check that the device is connected to the mains voltage.</p> <p>Connect the telephone cable to the socket marked FAX/☎. Insert the telephone plug into your PTT line socket.</p> <p>If possible test your device in another telephone line before you contact technical customer services.</p> <p>Follow the instructions on the display.</p>

Problems with Faxing	Possible Cause(s)
Fax transmissions are constantly interrupted.	It is possible that the recipient's device is not ready to receive.
Fax transmissions are constantly interrupted. Very long fax transmission times	<p>The ECM process reduces transmission errors. A poor connection can lead to long transmission times or to an interruption in the transmission. Deactivate the function:</p> <ol style="list-style-type: none"> 1. Press C, 0 0 1 4 and OK. 2. Use ▲/▼ to select whether you would like to turn the function on or off. 3. Confirm with OK.
Fax transmission to a fax number is not possible.	Call the number and check whether the number is a fax number and whether the connected fax device is ready to receive (whistling tone or silence).
Faxes sent are of poor quality.	<p>Modify the resolution.</p> <p>Test the device by making a copy of the document. If the device is in order, the device of the recipient might be defective.</p> <p>Test the scanner by printing the functions list (press C, 8 1 and OK). If the function list is printed perfectly, it is possible the scanner is dirty or defective. Clean the scanner.</p>
Fax recipient receives an empty sheet.	Lay the document onto the flatbed scanner with the written side down.
No fax reception	<p>Verify if the fax was received and not printed (green light  on the panel is illuminated).</p> <p>Check whether the manual fax reception mode is set. The device will not receive faxes on its own (see also chapter <i>Setting the Fax Reception Mode</i>, page 54).</p> <p>It is possible that the fax reception speed needs to be reduced (see also chapter <i>Reducing the Reception Speed</i>, page 56).</p>
No fax reception or sending	Verify whether your device is connected to a Voice over IP system (VoIP) or to an analogue telephone adapter (ATA). It is most likely that you will have to reduce the transfer speed or the reception speed (see also chapter <i>Reducing the Reception Speed</i> , page 56) (see also chapter <i>Reducing Transmission Speed</i> , page 55). If necessary, ask your telecommunications provider.

Problems with Faxing	Possible Cause(s)
Received faxes are not printed.	It is likely that secure fax reception has been activated. In that case, incoming faxes are not printed out, but rather are stored in the fax memory (see also chapter <i>Setting Protected Fax Reception</i> , page 44).
You hear a whistling tone or silence in the handset.	The call is a fax. Press  on the device. Press   on the additional telephone. Hang up.

Problems Printing or Copying	Possible Cause(s)
No printing Printing is interrupted.	Paper or document jam, no paper or toner cartridge. Follow the instructions on the display. There could be a small pause after printing several pages. The device continues printing automatically.
Copy is blank.	Insert the documents face down into the document feeder. No toner cartridge inserted.
The device produces white lines when printing.	Clean the toner drum with a soft cloth. Clean the scanner and the document feed slot (see also chapter <i>Cleaning</i> , page 66).
The device produces black lines when printing.	Clean the scanner and the document feed slot (see also chapter <i>Cleaning</i> , page 66). The toner cartridge is damaged and must be replaced. Use only original consumable materials.
The device produces vertical lines when printing.	It is possible that the scanner needs calibrating (see also chapter <i>Calibrating the Scanner</i> , page 67).
The device is making light gray or pale vertical stripes when printing.	Remove the toner cartridge from the device. Tilt the toner cartridge back and forth several times in order to distribute the toner evenly, thereby improving the print quality. Please note the instructions for the safe use of consumable materials (see also chapter <i>Consumable Materials</i> , page 6).
The device makes a noise during printing.	The toner cartridge is almost empty and must be replaced. Use only original consumable materials.
Received faxes and copies are too light.	The sender's device is not set optimally. If the copy is also too light the toner is almost all gone and must be replaced. Use only original consumable materials. Verify that the ecological saving function for the toner is activated (see also chapter <i>Set Up Toner Saving Function</i> , page 51).



Error Messages and Possible Causes

General Error Messages	Possible Cause(s)
INSERT PAPER	Paper must be inserted into the manual paper feed (see also chapter <i>Load Paper into the Manual Paper Feed</i> , page 25).
MEMORY FULL	Fax memory full! If the fax memory is full, no fax messages can be received. Print the stored fax messages so that the device is ready to receive again.
REMOVE PAPER	A document jam has occurred: Remove all documents from the document feeder. Clear the paper jam.
PAPER JAM	<p>A paper jam occurred: Check all the following three areas for jammed paper: Paper tray/paper feed, print unit and duplex unit/fuser unit (see also chapter <i>Fixing a Paper Jam</i>, page 64).</p> <p>Clear the paper jam. Press  after the problem has been rectified to continue the print job. Press  to suppress the error message.</p>
WRONG PAPER PAPER SIZE	<p>Problem with the paper format inserted. Make sure that you are using the proper paper format. Repeat the print job or copy process.</p> <p>There is no paper in the paper tray or the paper is not loaded correctly. Check the paper tray.</p>
TONER LOW	The toner cartridge is almost empty and must be replaced soon. Use only original consumable materials.
TONER EMPTY NON GENUINETONER NOT INSTALLEDTONER	<p>Problems with the toner cartridge: Toner cartridge empty, damaged, incorrect or no toner cartridge in device. Check the paper tray (see also chapter <i>Changing the Toner Cartridge</i>, page 62).</p> <p>The toner cartridge is empty and must be replaced. Use only original consumable materials.</p>
DEFECT TONER	The toner cartridge is not inserted correctly or can not be detected. Remove the toner cartridge from the device and insert the toner cartridge again. If the problem repeats, is the toner cartridge damaged and must be replaced (see also chapter <i>Changing the Toner Cartridge</i> , page 62). Use only original consumable materials.
PRINT JOB ERROR	Error when printing or copying. Print job is aborted. Repeat the print job or copy process.
COOLING PRINTER	There could be a small pause after printing several pages. The device continues printing automatically.
PRINTER SYSTEMERROR FUSER UNITERROR PAPER FEEDER ERROR LED ERROR SCANNER ERROR ROLLER DIRTY	Device error! Use the quick help (see also chapter <i>Power Cycling</i> , page 68). If the problem repeats, please contact our technical customer service or your retailer.

USB Storage Medium Error Messages	Possible Cause(s)
MEDIA FULL	No storage space is available on the inserted USB storage medium (USB stick, external hard drive, etc.). Purge the data media or delete files to create storage space.
MEDIA MISSING	There is no USB storage medium (USB stick, external hard drive) connected to the device. Check whether a USB storage medium is connected. Disconnect this and connect it again.
WRONG MEDIA	The inserted USB storage medium cannot be accessed (no read/write access). It is possible the USB storage medium is damaged or uses an unsupported file system. The device only recognises storage media which are formatted with FAT16 or FAT32 . NTFS is not supported.
USB OVERLOAD	The power consumption is too high or a USB device is defective. All USB devices are deactivated. <ol style="list-style-type: none"> 1. Remove all connected USB devices. 2. Press \diamond. 3. Insert another USB device into the device. Note with which USB device the error message occurs. <p>You can only connect one high power device (USB 2.0) to each USB connection. Do not connect additional devices—such as batteries, fans, charging devices—to your machine.</p>

Error Messages on the Transmission Report

Error Messages on the Transmission Report	Possible Cause(s)
<i>General scanner error</i>	A problem has occurred during the scanning process.
<i>User break</i>	The transmission process was interrupted by pressing the \odot -key on the transmitting unit.
<i>Busy or no fax answer</i> <i>Subscriber has disconnected</i>	If the subscriber is busy, the device dials the number again after some time. After six attempts, the transmission process is cancelled. Try again at a later date. Call the number and check whether the number is a fax number and whether the connected fax device is ready to receive (whistling tone or silence). Press FAX or \diamond to send the message manually. Ask the recipient whether the device is ready to receive.
<i>Non programmed number</i>	The recipient's number is no longer stored in the device. This can occur, for example, if you have selected the telephone book entry as a recipient for a fax message which should be sent at a later time and delete the telephone book entry before the time of transmission.
<i>Disconnected</i> <i>Can't communicate</i> <i>Subscriber has stopped</i> <i>Check called number</i>	The transmission process was interrupted. Repeat the transmission process. Call the number and check whether the number is a fax number and whether the connected fax device is ready to receive (whistling tone or silence). Press FAX or \diamond to send the message manually. Ask the recipient whether the device is ready to receive. Repeat the transmission process with a lower transmission speed (see also chapter <i>Reducing Transmission Speed</i> , page 55).

Error Messages on the Transmission Report	Possible Cause(s)
Transmission failed	<p>Fax Transmission: Repeat the transmission process. Call the number and check whether the number is a fax number and whether the connected fax device is ready to receive (whistling tone or silence). Press FAX or  to send the message manually.</p> <p>Ask the recipient whether the device is ready to receive.</p> <p>Fax Reception: Fax reception was interrupted. Ask the sender to send the fax message again.</p>
Voice contact	<p>Call the number and check whether the number is a fax number and whether the connected fax device is ready to receive (whistling tone or silence). Press FAX or  to send the message manually.</p>
QUALITY	<p>It is possible the error occurred because the recipient's number does not support the Error Correction Mode.</p> <p>Fax Transmission: The fax message sent was not received properly. Ask the recipient whether the transmission process needs to be repeated.</p> <p>Fax Reception: If the received fax message is illegible, ask the sender to send the fax message again.</p>
Memory full	<p>Fax memory full! If the fax memory is full, no fax messages can be received. Print the stored fax messages so that the device is ready to receive again.</p>
Internal error	<p>An error has occurred during printing of the received fax message.</p> <p>Check whether the device cover is open.</p> <p>Check whether the manual fax reception mode is set (see also chapter <i>Insert Paper into the Paper Tray</i>, page 23).</p> <p>Check whether cartridge is empty (see also chapter <i>Displaying the Toner Level</i>, page 61) (see also chapter <i>Changing the Toner Cartridge</i>, page 62).</p> <p>Check to see whether a paper jam has occurred (see also chapter <i>Fixing a Paper Jam</i>, page 64).</p>
Received document error	<p>The received fax message is possibly incomplete. Ask the sender to check the length of the fax message. It is possible the message is too long to be able to transmit in full.</p>
No document to be polled	<p>In selected devices, no documents lay ready which could be retrieved. Perhaps the sender's device is not ready or the document is no longer available.</p>
Incompatible coding	<p>Fax transmission to mailbox: The mailbox number entered does not exist at the recipient's side.</p>
Unknown Mailbox number	<p>Fax polling from a mailbox: The mailbox number entered does not exist at the recipient's side.</p>

Glossary

EN

Asymmetric Digital Subscriber Line (ADSL).

See Digital Subscriber Line (DSL)

Broadcasting

see Sending to Multiple Recipients

call hold

See Call Toggling

Call Toggling

You can switch back and forth between different telephone conversations by using the R key. The inactive telephone conversation is maintained in the interim, and the other party cannot listen in. This additional service must be enabled for your telephone line (see Call Waiting, see Flash Key).

Call Waiting

If another caller places a call to you while you are having a telephone conversation, you will hear a tone. If additional services are enabled for your telephone line, you can toggle back and forth between different telephone calls (see Flash Key; see Call Toggling).

Call-by-Call

Selection of the telephone service provider for each telephone call. It is possible to place telephone calls through different private service providers. By placing prefixes in front of the actual telephone number, one can choose a different service provider for each telephone call without entering into a firm contract relationship.

Caller List

The numbers of the last callers are stored in the caller list. This function requires that the caller identification function be enabled for your telephone line and that the caller not suppress the transmission of his or her telephone number (see Calling Line Identification).

Calling Line Identification (CLIP)

There are two types of Calling Line Identification Presentation (CLIP). If someone calls you, your device will show the caller's telephone number on the display. If another caller places a call to you while you are having a telephone conversation, you will hear a tone. Your telephone company must offer both services and must enable them for your telephone line. The transmission of your telephone number can be turned on and off temporarily or it can be turned off permanently (Calling Line Identification Restriction, CLIR).

CCITT

Comite Consultatif International Téléphonique et Télégraphique (predecessor of ITU)

CE

Conformité Européenne

Chain Dialling

see Combining Numbers

Chain Dialling

Before the dialling process begins, you can freely combine and edit telephone book entries, manually entered digits, numbers from the redial list or numbers from the caller list. For example, if you have saved the telephone number prefix of an inexpensive telephone service-provider (see Call-by-Call) as a telephone book entry, select this entry and manually enter the desired telephone number or select another number from the telephone book, the redial list or the caller list.

CLIP

Calling Line Identification Presentation (see Calling Line Identification)

CLIR

Calling Line Identification Restriction (see Calling Line Identification)

CNG

Calling Signal (see Fax Signal)

Dialling Pause

Long-distance numbers or telephone numbers with sub-addresses/extensions sometimes require the insertion of a dialling pause to prevent the dialling from occurring too quickly and resulting in a loss of the connection. The second part of the number is dialled only after a short pause.

Digital Subscriber Line (DSL)

Data connection for private households or companies with high transmission speeds (broadband connection) usually for connection to the Internet. Fixed network telephone lines can be used for the DSL connection. Due to the frequency range used, Internet use via DSL can be used simultaneously with the telephone line. For private households, there are usually connections with different transmission speeds: Asymmetric Digital Subscriber Line (ADSL). A high download rate alongside a far lower upload speed.

Direct-Dial Number

Number used to directly dial a specific extension of a private branch exchange.

DTMF

Dual Tone Multi Frequency (see Tone Dialling)

Dual Tone Multi-Frequency (DTMF)

see Tone Dialling

Easylink

The Easylink function offers you additional options for managing external devices that are connected to the same telephone line as your device (starting fax reception, taking over the line, see Additional Devices). To use this function, additional telephones must be set to tone dialling (DTMF tones).

ECM

Error Correction Mode

Encoding

The data of your fax transmission are encoded and compressed for the transmission. The minimum standard is MH (Modified Huffmann). Better encoding methods are MR (Modified Read) or MMR (Modified Modified Read).

Error Correction Mode (ECM)

The ECM method reduces transmission errors that result, for example, from bad telephone lines, thereby reducing the duration of transmissions. Both of the connected fax machines must support ECM.

Fax Groups

Fax machines are classified in terms of internationally standardised fax groups based on their transfer type and speed. Connections between two devices of different groups is possible; the lowest common transfer rate is selected. The determination of the speed takes place during the handshake (see Handshake). Fax groups 1 to 3 are analogue fax machines. Nowadays, groups 1 and 2 are hardly to be found any longer; fax machines of group 3—which have a transfer speed that ranges from 9,600 to 33,600 bps—are currently most standard. Group 4 fax machines are digital devices that function exclusively on ISDN systems. They have a maximum transfer speed of 64,000 bps.

Fax Polling

With active fax polling, one can retrieve a document from another fax machine. For fax polling from a larger company offering several polling services, you can also enter sub-addresses / direct-dial numbers. In order to do this, you must insert a dialling pause between the fax number and the sub-address (see Dialling Pause).

Fax Signal, CNG Tone (= Calling Signal)

The tone that a fax machine sends out to announce a fax transmission. When the CNG tone occurs, the fax switch of the device recognises an incoming fax call and starts the fax reception.

Fax Switch

The fax switch checks incoming telephone calls and controls the ringing behaviour of the fax machine. According to the selected mode, fax transmissions will be received either automatically or manually.

Flash Key (R-key)

With the flash key, you can make use of additional telephone services if these special functions are enabled for your telephone line. The R key has replaced the hook-flash function. (see Call Waiting, Call-toggling).

Handshake

The handshake is the initial and final phase of a fax transmission. After establishing of the connection, fax machines check the group affiliation and features such as size compression or grey tones. After the fax transmission has been completed and before the connection is terminated, the receiving device confirms receipt of the transmission (see Fax Groups).

Hook-Flash Function

See Flash Key

ISDN

Integrated Services Digital Network

ITU

International Telecommunications Union (UN organisation)

LCD

Liquid Crystal Display

Memory

If there is no paper or toner in your device, the device will store incoming fax transmissions in its memory.

MH

Modified Huffmann (encoding process for faxes, see Encoding)

MMR

Modified Modified Read (encoding process for faxes, see Encoding)

MR

Modified Read (encoding process for faxes, see Encoding)

Outside Line Access Code

The outside line access code is the number or letter that must be dialled before the actual telephone number on a telephone of a private branch exchange in order to establish a connection to the public telephone network (see Private Branch Exchange).

PABX/PBX

Private Automatic Branch Exchange

Polling

see Fax Polling

POTS

Plain Old Telephone Service

Private Branch Exchange

Private branch exchanges are common in larger companies. Even private ISDN systems can be branch exchanges. To establish a connection to the public telephone network from a private branch exchange, one must dial a number or press a key before the actual telephone number; in most cases this is zero (see Outside Line Access Code).

PSTN

Public Switched Telephone Network

Pulse Dialling

A dialling process that is used in older telephone networks. You hear a clicking for each number dialled (see Tone Dialling).

RJ-11

Registered Jack 11 (also called Western plug, standardised telephone plug)

Scanning

The reading of a document into the fax memory or into the computer in order to send it, copy it or edit it.

Sender Identification (= Header)

The telephone number and name of the sender as well as the date and time of the fax transmission appear in the upper margin of each received fax.

Sending to Multiple Recipients (= Broadcasting)

With this function, you can send a fax message to multiple recipients.

Telephone number suppression (CLIR)

If you call a subscriber, your number appears on the display of the person whom you are calling. You can switch off this function and suppress your number (Caller Line Identification Restriction, CLIR).

Time Stamp

The exact date and time of receipt appear in the page header of each received fax. A memory buffer guarantees that exact data are issued even after a power loss. In this way, you can verify exactly when a fax has reached you.

Tone Dialling (= Dual Tone Multi-Frequency)

In many countries, tone dialling has replaced pulse dialling, in which each number was sent as a corresponding number of pulses. With tone dialling, a specific tone is assigned to each key (referred to as DTMF tones).

Toner Level Memory

Your device registers the extent of toner used for every print-out and calculates the toner level of the toner cartridge on that basis. The toner level is stored in each toner cartridge. You can use different toner cartridges as well as display the respective toner level of the toner cartridge.

Transfer Speed

CCITT/ITU has published international standards for the transmission of data over telephone lines. All short names begin with V, so these are also referred to as V standards. The most important transmission speeds for fax transmissions are: V.17—7.200 to 14.400 bps, V.21—max. 300 bps, V.22—max. 1.200 bps, V.22 bis—max. 2.400 bps, V.27 ter—max. 4.800 bps, V.29—max. 9.600 bps, V.32 bis—max. 14.400 bps, V.34—max. 33.600 bps

TWAIN

(Tool Without an Interesting Name) With the TWAIN scanner driver you can access the device and scan documents from any application which supports this standard.

USB

Universal Serial Bus (computer port)

UTC

Coordinated Universal Time (UTC) Coordinated Universal Time is the current standardised universal time used. Starting from Greenwich in London (Zero Meridian), the world is split into time zones. These time zones are indicated with a deviance from UTC (in hours) for instance UTC+1 for Central European Time (CET)

Warm-Up Phase

Normally, the device is in the energy saving mode (see Energy Saving Mode). In the warm-up phase, the device heats up the printing unit until it has reached the necessary operating temperature, after which the copy or fax can be printed out.

16 Appendix

Technical Data

Dimensions (L × H × W)	430 × 346 × 393 mm
Weight	< 12 kg
Mains Connection	220–240 V ~ / 50–60 Hz
Power Consumption	
Stand-by Mode	< 5,5 W
Warm Up Phase	< 980 W
Printing	< 550 W
Recommended Ambient	18–28 °C
Relative Humidity	30–70% (non-condensing)
Connection Type	PSTN · PABX
Dialling Mode	Tone / pulse dialling (country dependent)

Standards

Safety	EN 60950-1 EN 60825-1
Emissions	EN 55022 Class B EN 61000-3-2 EN 61000-3-3
Immunity	EN 55024
Noise emission values based on ISO 9296	
Stand-by	< 30 dB(A)
Operation	< 55 dB(A)

Scanner

Type	Black-and-White 256 grey tones
Scan Width	216 mm
Resolution	
Draft grey tones	100 dpi
Text Black-and-White	200 dpi
Grey tones grey tones	200 dpi
Photo grey tones	400 dpi
Speed	
Standard	3,9 seconds/A4-page
Fine	3,9 seconds/A4-page
SFine	10,2 seconds/A4-page

Printer

Type	Class 1 Laser Printer
Emulation	GDII
Warm-Up Time	< 10 sec.
Width	211 mm
Resolution	600 × 600 dpi 600 × 1200 dpi
Speed	24 pages/minute

Memory

Redial / caller list	50 Entries
Telephone Book	250 Entries
Fax Messages	up to 200 pages (standard test letter)

Paper (Paper Tray)

Capacity	250 sheets
Size	A4 · A5 · B5 (JIS) Letter · Legal (13/14") Exec · Custom
Weight	60–105 g/m ²

Paper (Manual Paper Feed)

Capacity	1 sheets
Width	98–216 mm
Length	148–356 mm
Weight	60–165 g/m ²

Fax

Type	Group 3
Compatibility	ITU-T.T.30
Data Compression	MH · MR · MMR · JBIG
Modulation	V.17, V.21, V.27ter, V.29, V.34
Resolution	
Standard	100 dpi
Fine	200 dpi
Super Fine	400 dpi
Photo	400 dpi
Transfer Speed	33.600 bps

Copier

Type	Black-and-White 256 grey tones
Resolution	
Automatic	200x203 dpi
Text	200x203 dpi
Quality	400x203 dpi
Photo	400x203 dpi
Speed	up to 24 pages/minute
Multiple Copies	up to 99

Computer-/Network Connection

Connection Type	USB 2.0 (High Speed) (downwards compatible to USB 1.1)
	Wireless LAN (optional)
WLAN protocol	802.11b - g compatible with 802.11n
Supported Operating Systems	
	Microsoft Windows 2000 (SP 4) · XP · Vista Windows 7 · Windows Server 2003/2008
	Apple Macintosh OS 10.4 · 10.5 · 10.6
	Linux Redhat 9.0 · Debian 5.0 · Suse 11.1 Fedora 11 · Ubuntu 9.10

Technical specifications subject to change without notice.

Guarantee

(Terms and Conditions for United Kingdom only)

In order to supply the guarantee, you should contact your dealer or Sagemcom Helpdesk. The proof of purchase will be required.

Please make usage of your equipment for the purpose for which it was designed and under normal usage conditions. Sagemcom do not accept any liability for any usage made out of the frame of its original designed purpose and any consequence that may arise from this usage.

Should any malfunctioning arise, the dealer or Sagemcom Helpdesk will advise you what to do.

A) General Guarantee Conditions

Sagemcom undertakes to remedy by repair or exchange at its own convenience, free of charge for labour and replacement parts, any defects in the equipment during the guarantee period of 12—twelve—months (3—three—months for accessories), from the date of original invoice of the Equipment, where those defects are a result of faulty workmanship.

Unless the customer has concluded with Sagemcom a maintenance contract in respect of the equipment which specifically provides for repairs to be carried out at the customer's premises, the repairs will not be carried out on the equipment at the customer premises. The customer must however return the defective equipment at his/her own expense, to the address given by the dealer or Sagemcom Helpdesk.

In case a product needs to be sent in for a repair, it always has to be accompanied by a proof of purchase (which is not altered, written on or in any way be made illegible) showing that the product is still under warranty. In case no proof of purchase is enclosed, the Sagemcom repair center will use the production date as a reference of establishing the warranty status of the product.

Apart from all legal obligatory rules, Sagemcom, do not give any Guarantee, either implicit or explicit which is not set force in the present section, and could not be held responsible for any direct or indirect, material or immaterial damage, in or out of the frame of the present guarantee.

If any provision of this guarantee shall be held to be in whole or in part invalid or illegal due to an obligatory rule applicable to consumers pursuant to their national legislation, such invalidity or illegality shall not impair or affect the remaining provisions or parts of this guarantee.

This guarantee does not affect the Customer statutory rights.

B) Exclusions From Guarantee

Sagemcom shall have no liability under the guarantee in respect of:

-) Damage, defects, breakdown or malfunction due to one or more of the following:

- Failure to properly follow the installation process and instructions for use

- An external cause to the equipment (including but not limited to: lightning, fire, shock, vandalism, inappropriate conditions of electrical network or water damage of any nature)

- Modifications made without the written approval of Sagemcom

- Unsuitable operating conditions, particularly of temperature and humidity

- Repair or maintenance of the equipment by persons not authorized by Sagemcom

-) Wear and tear from normal daily use of the equipment and its accessories

-) Damage due to insufficient or bad packaging of equipment when returned to Sagemcom

-) Usage of new versions of software without previous approval of Sagemcom

-) Work on any equipment or software modified or added without the prior written consent of Sagemcom

-) Malfunctions not resulting from the Equipment or from software installed in user workstations for the purpose of use of the equipment.

Communication problems related to an unsuitable environment including:

- Problems related to access and/or connection to the Internet such as interruptions by access networks or malfunction of the line used by the subscriber or his correspondent

- Transmission faults (for example poor geographical coverage by radio transmitters, interference or poor line quality)

- The local network fault (wiring, servers, workstations) or the failure of the transmission network (such as but not limited to interferences, fault or poor quality of the network)

- Modification of the parameters of the cellular network carried out after the sale of the Product

-) The normal servicing (as defined in the user guide supplied with the equipment) as well as malfunctioning due to servicing not being carried out. Servicing costs are in any event always borne by the customer.

-) Malfunctions resulting from the usage of products, consumables or accessories not compatibles with the equipment.

C) Out of Guarantee Repairs

In the cases set forth in B) as well as after expiry of the guarantee period, the customer must ask the Authorized Sagemcom Repair Centre for a cost estimation.

The repair and delivery costs will be invoiced to the customer.

The foregoing shall apply unless otherwise agreed in writing with the customer and only for the United Kingdom.



The CE symbol confirms conformity with the EU directives that apply to the device.

Declaration of Conformity (DoC)

Hereby, **Sagemcom Documents SAS** declares that this **SFF 6135d** is in compliance with the essential requirements and other relevant provisions of Directive 1999/5/EC.

You can find the complete Declaration of Conformity on our website www.philips.com



As a participant in the ENERGY STAR programme, Sagemcom Documents SAS has made sure that this device complies with the ENERGY STAR requirements.



Packaging: To facilitate packaging recycling, please conform to your local selective recycling rules.

Batteries: Old batteries have to be deposited in designated collection areas.



Product: The crossed out dustbin logo on your product signifies it is classified as Electrical and Electronic Equipment covered by special disposal regulations.

To enforce recycling, recovery of The Waste Electrical and Electronic Equipment (WEEE) and to protect the environment and human health, European regulations requires that you selectively collect waste equipment using one of the following options :

- Your retailer will take your equipment back if you are buying a replacement product.
- Waste equipment can also be deposited in designated collection areas.

The paper and cardboard packaging used can be disposed of as recyclable paper. Have the plastic wrapping and Styrofoam packaging recycled or dispose of it in the non-recyclable waste, depending on the requirements in your country.

Trademarks: The references mentioned in this manual are trademarks of the respective companies. The lack of the trademarks ® and ™ does not justify the assumption that these dedicated terminologies are free trademarks. Other product names used herein are for identification purposes only and may be trademarks of their respective owners. Sagemcom disclaims any and all rights in those marks.

The reproduction of certain documents (e.g. by scanning, printing, copying) is prohibited in many countries. The list of such documents below is not intended to be complete, it only offers a general overview. In case of doubt, consult your legal advisor.

- Passports (personal identification)
- Entrance and exit visa papers (immigration papers)
- Military service documents
- Bank notes, travel checks, payment orders
- Postage stamps, tax stamps (stamped or unstamped)
- Loan papers, certificates of deposit, bonds
- Documents protected by copyright

Follow the statutory regulations of your country with regard to the legal validity of fax transmissions—particularly in connection with the validity of signatures, meeting delivery deadlines or disadvantages resulting from the loss of quality in the transmission, etc.

Take care to maintain the statutory regulations of your country regarding telecommunications secrecy and data privacy.

This product is intended for use on an analogue public telecommunications network (PSTN) and in the country specified on the packaging. Use in other countries can result in faulty functioning.

For more information, please contact the technical service centre for your country. Should problems arise during use of your device, please contact your retailer first.

Neither Sagemcom nor its affiliates shall be liable to the purchaser of this product or third parties for damages, losses, costs, or expenses incurred by the purchaser or third parties as a result of accident, misuse, or abuse of this product or unauthorized modifications, repairs, or alterations to this product, or failure to strictly comply with Sagemcom operating and maintenance instructions.

Sagemcom shall not be liable for any damages or problems arising from the use of any options or any consumable materials other than those designated as original Sagemcom products or Sagemcom approved products.

Sagemcom shall not be held liable for any damage resulting from electromagnetic interference that occurs from the use of any interface cables other than those designated as Sagemcom products.

All rights reserved. No part of this publication may be reproduced, stored in a retrieval system or transmitted in any form or by any means, electronic, mechanical, photocopying, recording, or otherwise, without the prior written permission of Sagemcom. The information contained herein is designed only for use with this product. Sagemcom is not responsible, if this information is applied to other devices.

This user manual is a document that does not represent a contract.

Errors, printing errors and changes are reserved.

Copyright © 2011 Sagemcom Documents SAS

Customer Information

As part of our continuing quest for total customer satisfaction, all of our products are made with ease-of-use and reliability in mind.

In your user manual you will find all the information required to use your machine. If, after consulting your user manual, you still require assistance, you should contact our Call Centre. Our personnel are highly trained specialists who can ensure that you receive the maximum benefit from your product.

We can assist you more quickly if you do not call us from the machine, rather an external telephone. Keep a printout of the settings as well as the serial number of the machine handy. The serial number can be found on the type label.

Should problems with the computer connection arise, have the following information to hand when you contact technical customer services: hardware configuration of your computer, operating system installed and security programmes used (anti-virus programmes, firewall). Then we can help you more quickly.

United Kingdom

Telephone: 08 45 - 090 03 15 (0,10 £/minute)

Fax: 08 70 - 124 02 02

You can order original accessories from our homepage or—in some countries (see below)—per telephone on our toll-free number.

Use only original consumable materials. The warrantee does not cover damages to the device resulting from other consumables.

United Kingdom

Telephone: 0800 - 358 08 07

E-Mail: support.service@sagemcom.com

Internet: www.philips.com

We hope that you will have lots of joy using your new product.



PHILIPS and the PHILIPS' Shield Emblem are registered trademarks of Koninklijke Philips Electronics N.V. and are used by Sagemcom under license from Koninklijke Philips Electronics N.V.

Sagemcom Documents SAS

Documents Business Unit

Headquarters : 250, route de l'Empereur
92500 Rueil-Malmaison Cedex · FRANCE
Tel: +33 (0)1 57 61 10 00 · Fax: +33 (0)1 57 61 10 01
www.sagemcom.com

Simplified Joint Stock Company · Capital 8.479.978 € · 509 448 841 RCS Nanterre

LaserMFD 6135hfd
UK · INT
253358244-C