

WARRANTY

(Effective January 1, 2007)

HIX will automatically register the equipment on the date it was shipped to you or your distributor. If the equipment was not purchased directly from HIX, but through a distributor (either domestic or foreign), please keep a copy of their sales invoice showing the serial number and date it was sold/shipped to you with this warranty. In this case, we will use the distributor's invoice date as the beginning warranty date. **STAPLE A COPY OF YOUR RECEIPT TO THIS WARRANTY** and keep in a safe place to provide verification of your warranty should a problem occur. Thank you.

Please fill in the following information and attach a copy of your receipt for your records.

Date Purchased: _____ From: _____
Model #: _____ Serial #: _____

This warranty applies to equipment manufactured by the HIX Corporation (HIX), Pittsburg, Kansas, U.S.A. HIX warrants to the original purchaser, its Conveyor Dryers, Heat Transfer Presses, Mug Presses, Mug Glazer, Retensionable Screen Frames, Textile Printers, Spot Heaters, and Exposure Units against defects in workmanship and material, except for wear and tear for a period of "One Year" from the date of purchase. HIX warrants its Accessories, Reten Spines/Hardware/Tool Kit, and Shuttle for a period of 90 days from the date of purchase. DoughXpress and Thermatrol products are covered under separate warranty.

In the event of a defect, HIX, at its option, will repair, replace or substitute the defective item at no cost during this period subject to the limitations of insurance and shipping costs stated below.

In the case of heat transfer presses (except the Mug Press, Hobby Lite), HIX warrants the heat casting for the "Life" of the machine for the original purchaser. If a part becomes obsolete at the time for repair, and/or cannot be reasonably substituted for, HIX will credit, at half the then current list price or last recorded price, only that part toward a new machine or any product HIX offers. This credit offer shall be the sole responsibility of the HIX Corporation in the event of an obsolete part.

This warranty does not cover belts, pads, mug wraps, mug press liners, canvas, rubber blankets, bulbs, glass, PTFE or finish, rod ends, turn buckles on printers, or mug press or damages due to accident, misuse/abuse, alterations or damage due to neglect, shipping or lack of proper lubrication or maintenance. HIX shall not be responsible for repairs or alterations made by any person without the prior written authorization by HIX. This warranty is the sole and exclusive warranty of HIX and no person, agent, distributor, or dealer of HIX is authorized to change, amend or modify the terms set forth herein, in whole or in part.

In the case of a problem with the equipment identified herein, HIX Corporation should be contacted during regular business hours to discuss the problem and verify an existing warranty. HIX personnel will assist the customer to correct any problems which can be corrected through operation or maintenance instructions, simple mechanical adjustments, or replacement of parts. In the event the problem cannot be corrected by phone, and upon the issuance of a return authorization by HIX, the equipment shall be returned to HIX or an authorized service representative. All insurance and shipment/freight costs are solely the responsibility of the customer, and not that of HIX, and HIX shall not be responsible for improper handling or damage in transit. HIX offers a reconditioning service and a core exchange/credit policy on some models. HIX customer service personnel may be contacted for complete return authorization and reconditioning information.

This expressed warranty is given in lieu of any and all other warranties, whether expressed or implied, including but not limited to those of merchantability and fitness for a particular purpose, and constitutes the only warranty made by HIX Corporation.

In no event shall HIX's liability for breach of warranty extend beyond the obligation to repair or replace the nonconforming goods. HIX shall not be liable for any other damages, either incidental or consequential, or the action as brought in contract, negligence or otherwise.

This warranty gives you specific legal rights and you may also have other rights which vary from state to state.

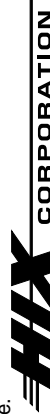

Manufacturers of the Finest Quality Textile and Graphics Screen Printing and Heat Transfer Equipment

1201 E. 27th Terrace • Pittsburg, KS 66762 • U.S.A.
Web site: www.hixcorp.com • Phone: (800) 835-0606
E-Mail: customerservice@hixcorp.com • Fax: (866) 561-0894
E-Mail: sales@hixcorp.com • Fax: (866) 563-4600

SwingMan

16"x20" Swing Away Heat Press

OWNER'S MANUAL



Swingman 20D



For Customer Service, Call 1-800-835-0606
ext. 209, ext. 211, ext. 220, ext. 221 or

Visit www.hixcorp.com

CONTENTS

Receiving and Shipping	2
Installation and Preparation	3
Operation	2-3
Transfer Application	4
Maintenance & Repairs	5
Parts Identification (Exploded View / Parts List)	5-6
Warranty	8

BEFORE warranty repair you **MUST** get Prior Authorization:
Call 1-800-835-0606

RECEIVING AND SHIPPING

UNPACKING

Remember to save all packing materials - including box, liner and board. You may need these for shipping your machine or if a repair is necessary in the future.

INSPECTION

Inspect your machine for hidden shipping damage. Contact the delivery company immediately, should you find damage.

SHIPPING OR RETURNS

NOTE: Save all of your shipping/packing materials.
DO NOT RISK COSTLY SHIPPING DAMAGE!
SHIP ONLY IN ORIGINAL BOX.

1. Fasten machine to plywood shipping base with bolts provided.
2. Make sure handle is tied down (do not tape directly onto painted surfaces) so that the heat platen will not swing around during shipment.
3. Place in original box, put side liner and top liner in place. Fold in flaps and seal/tape the box.
(Additional bottom boards, box and liners may be obtained from HIX at a nominal cost.)

OPERATION

NOTICE: These machines are *heavy* get help, team lift with your legs when placing the machine.

INSTALLATION

1. Remove plywood shipping base, peel away protector sheet and apply self adhesive rubber feet to bottom (outer points) of legs.
2. Plug the machine into the correct grounded electrical outlet.
WARNING: When using an extension cord, use 12 or 14 ga.-3 conductor. Maximum length, 25' (7.62 m).

PARTS IDENTIFICATION

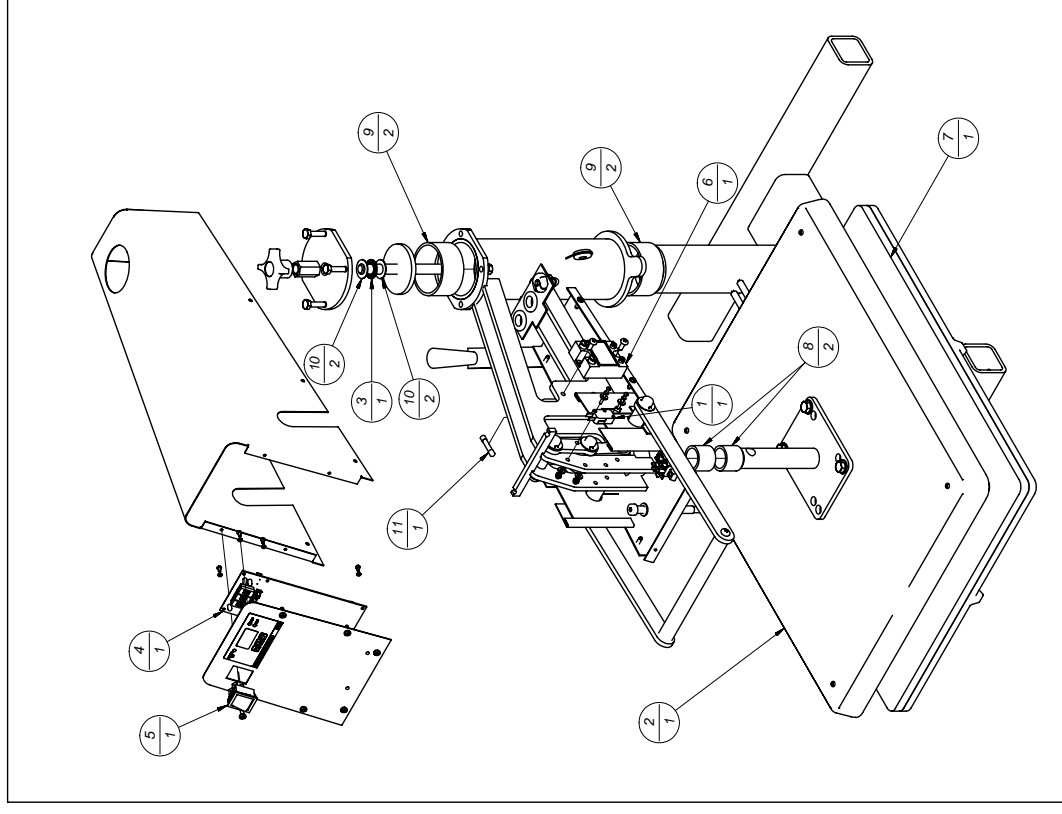

PARTS IDENTIFICATION

PARTS LIST

Parts List		
ITEM	QTY	PART NUMBER DESCRIPTION
1	1	31823 MICROSWITCH ASSY
2	1	14044 PLATEN 16X20 120V
	1	14036 PLATEN 16 x 20 220v
3	1	63622 BEARING, THRUST 1/2x7/8
4	1	65312 CONTROL HTM 120V
	1	65322 CONTROL HTM 220V
5	1	32581 SWITCH ROCKER 120v
	1	33754 SWITCH ROCKER 220v
6	1	65897 RELAY SS 50A 3-32VDC INPUT 120v
	1	62731 RELAY SS 25A 3-32VDC INPUT 220v
7	1	50545 PAD PRECUT 16x20
8	1	70602 BEARING BRZ 1.000X1.2525X2
9	2	68853 BEARING BRZ 2.377X2.6295X1.250
10	2	63320 WASHER THRUST 00500x00875
11	1	13045 FUSE MDA-15 AMP 120v
	1	76752 FUSE MDA-10 AMP 220v

OPERATION

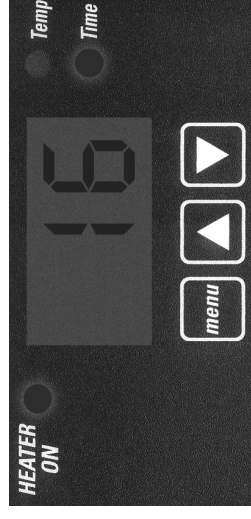

TIME/DISPLAY INSTRUCTIONS

The timer can be changed from “seconds” to “minutes and tenths of minutes XX.X” display, as follows.

1. Make sure the machine power is “OFF”.
2. Press and hold down the “MENU” and the “DOWN” arrow buttons in.
3. While holding the buttons in, turn the power “ON”.
4. Release the two buttons then press the menu button (twice) to scroll to the time setting. Adjust the time as necessary.
5. Press menu again to lock in your settings. After this, the control will operate normally and reset to your setting each time the handle of press is closed.

Note: To change the resolution back, repeat steps #1-4 again.

TEMPERATURE INSTRUCTIONS

1. Turn on the machine by pushing the on/off switch.
2. To change or set the temperature, press the menu button once. The light next to “TEMP” will light. Press the up ▲, or down ▼, button to your desired setting.
4. When you have your desired settings **press the menu button a third time to lock in your settings** otherwise the previous settings will still be in effect.
5. Wait for the machine to reach your preset temperature by monitoring the display temperature until it matches the set temperature.

OPERATION

PRESSURE Adjust pressure with machine open.

1. The pressure control knob, located on the top of the machine, should be set so that the heat head will lock down firmly.
2. Pressure is reduced by turning knob **counter-clockwise** and increased by turning it **clockwise**.

NOTE: Adjustments may be required from one garment to another and will vary to achieve the desired result.

CAUTION: Excessive pressure can cause structural damage, voiding the machine warranty!

TRANSFERS

TIME

Refer to the transfer makers guidelines for the application time.

TRANSFER APPLICATION

1. Check your transfer paper instructions to get the proper guidelines on temperature, pressure, pressing time, and whether to peel the transfer hot or cold.
2. Make sure that you have “mirrored” your image before printing out the transfer for inkjet or sublimation transfers. Exception if you produce glass tiles or image cutting boards, (where the image is on backside, coming through glass).
3. Swing the heat platen all the way out making sure not to come in contact with the electrical cord or any other item.
4. Align item on the lower platen and swing heat platen back and clamp down to test your pressure setting. **NOTE:** Wrinkles may also be removed by bringing heated platen in contact with the garment before the transfer is positioned.

Tip: When making tiles: the tile blanket/ or felt pad is placed on the lower platen first, then the transfer is placed face up. Next, the single or multiple tiles are placed face down onto transfer. (When doing sublimated transfers, always cover your pressed item with a PTFE blanket, to protect the upper platen. If a PTFE blanket is not available a piece of transfer paper will do.) See Fig. A and Fig. B on page 5.

TRANSFERS



Fig. A



Fig. B

5. Swing heat platen back out and position your transfer where you want it to appear on the garment (or other item) with printed side down.
6. Again, when doing double sided or sublimation transfers on garments, always place a sheet of transfer paper or a PTFE sheet between the layers of garments so that bleeding through or reheating of the transfer already applied does not occur.
7. Pull operating handle down locking the machine closed. Timer will automatically start counting. After the designated time has elapsed, timer will beep, this is your signal to open the machine.
8. **First**, remove the transfer as specified and **then** the product.
9. When not transferring, leave the heat platen up in order to prevent excessive wear on the silicone pad.

CAUTION: Tiles/Glass products are very hot wear protective gloves.

MAINTENANCE & REPAIRS

CLEANING THE HEAT PLATEN

1. Unplug the machine and allow to cool.
2. Swing the heat platen away for easier access.
3. Use a soap or detergent and nonmetallic scrubbing sponge to remove any excess material from the heat platen.

LUBRICATION

1. Every 3 months, lubricate moving parts with ordinary household oil.