

~~KAA~~

KAA

ZANUSSI

REFRIGERATOR

ZFC 85 L

INSTRUCTION BOOKLET



WARNINGS



IT IS MOST IMPORTANT THAT THIS INSTRUCTION BOOK SHOULD BE RETAINED WITH THE APPLIANCE FOR FUTURE REFERENCE. SHOULD THE APPLIANCE BE SOLD OR TRANSFERRED TO ANOTHER OWNER, OR SHOULD YOU MOVE HOUSE AND LEAVE THE APPLIANCE, ALWAYS ENSURE THAT THE BOOK IS SUPPLIED WITH THE APPLIANCE IN ORDER THAT THE NEW OWNER CAN GET TO KNOW THE FUNCTIONING OF THE APPLIANCE AND THE RELEVANT WARNINGS.

THESE WARNINGS ARE PROVIDED IN THE INTEREST OF SAFETY. YOU MUST READ THEM CAREFULLY BEFORE INSTALLING OR USING THE APPLIANCE.

General Safety

- This appliance is designed to be operated by adults. Children should not be allowed to tamper with the controls or play with the product.
- It is dangerous to alter the specifications or modify this product in any way.
- Care must be taken to ensure that the appliance does not stand on the electrical supply cable.
- Before defrosting, cleaning or maintenance work is carried out, be sure to switch off the appliance and unplug it.
- Do not remove items from the freezer if your hands are damp/wet, as this could cause skin abrasions or “frost/freezer burns”.
- Ice lollies can cause “frost/freezer burns” if consumed straight from the freezer.
- Frozen food must NOT be re-frozen once it has thawed out.
- Do not place carbonated or fizzy drinks in the freezer as it creates pressure on the container, which may cause it to explode, resulting in damage to the appliance.
- The cooling plate or refrigerated freezer shelves in this appliance contain channels through which the refrigerant passes. If these are punctured this would cause substantial damage to the appliance and result in food loss. **DO NOT USE SHARP INSTRUMENTS** to scrape off frost or ice. Under **NO** circumstances should solid ice be forced off the lining or shelves. Solid ice should be allowed to thaw, when defrosting the appliance. See Defrost instructions.
- Manufacturers’ storage recommendations should be strictly adhered to. Refer to relevant instructions.

Service / Repair

- Any electrical work required to install this appliance should be carried out by a qualified electrician or competent person.
- This product should be serviced by an authorised ZANUSSI Service Centre, and only genuine spare parts should be used.
- Under no circumstances should you attempt to repair the appliance yourself. Repairs carried out by inexperienced persons may cause injury or serious malfunctioning. Refer to your local ZANUSSI Service Centre and always insist on genuine spare parts.

Use

- ZANUSSI domestic refrigerators, freezers and fridge/freezers are designed to be used specifically for the storage of edible foodstuffs only.

Installation

- There are working parts in this product which heat up. Always ensure that there is adequate ventilation as a failure to do this will result in possible food loss. See installation instructions.
- Parts which heat up should not be exposed. Wherever possible, the back of the appliance should be close to a wall but leaving the required distance for ventilation as stated in the installation instructions.
- The appliance should be left for 2 hours after installation before it is turned on in order to allow the refrigerant to settle.
- This appliance is heavy. Care should be taken when moving it.

Environment Protection

- This appliance does not contain gasses which could damage the ozone layer, in either its refrigerant circuit or insulation materials. The appliance shall not be discarded together with the urban refuse and rubbish. Avoid damaging the cooling unit, especially at the rear near the heat exchanger. Information on your local disposal sites may be obtained from your municipal authorities.
The materials used on this appliance marked with the symbol  are recyclable.

When disposing of your old fridge, freezer or fridge/freezer.

Help to keep your country tidy – use authorised disposal sites for your old appliances.

For maximum efficiency:

Make sure that the appliance is cleaned properly.

Make sure that the door is closed properly.

Do not position the appliance near to sources of heat.

Do not over-fill your appliance, air **MUST** be allowed to circulate.

Description of the appliance	5
Installation	6
▪ Positioning	6
▪ Rear spacers	6
▪ The electrical connections	7
Technical specification	8
▪ Door reversal directions	9
Operation	10
▪ Setting the temperature	10
Health and safety guidelines	11
▪ Fresh food refrigeration	12
▪ Positioning the door shelves	12
▪ Use and features of the «CRISP’N FRESH» filter	13
▪ Cleaning the filter	13
▪ Cool check temperature guide	14
▪ Starting the appliance	14
▪ Everyday use of the cool check temperature guide	14
▪ Defrosting	15
Maintenance and cleaning	16
▪ Internal cleaning	16
▪ External cleaning	16
▪ When the appliance is not in use, Interior light	16
What happens if something goes wrong?	17
Guarantee conditions	18

DESCRIPTION OF THE APPLIANCE

GB

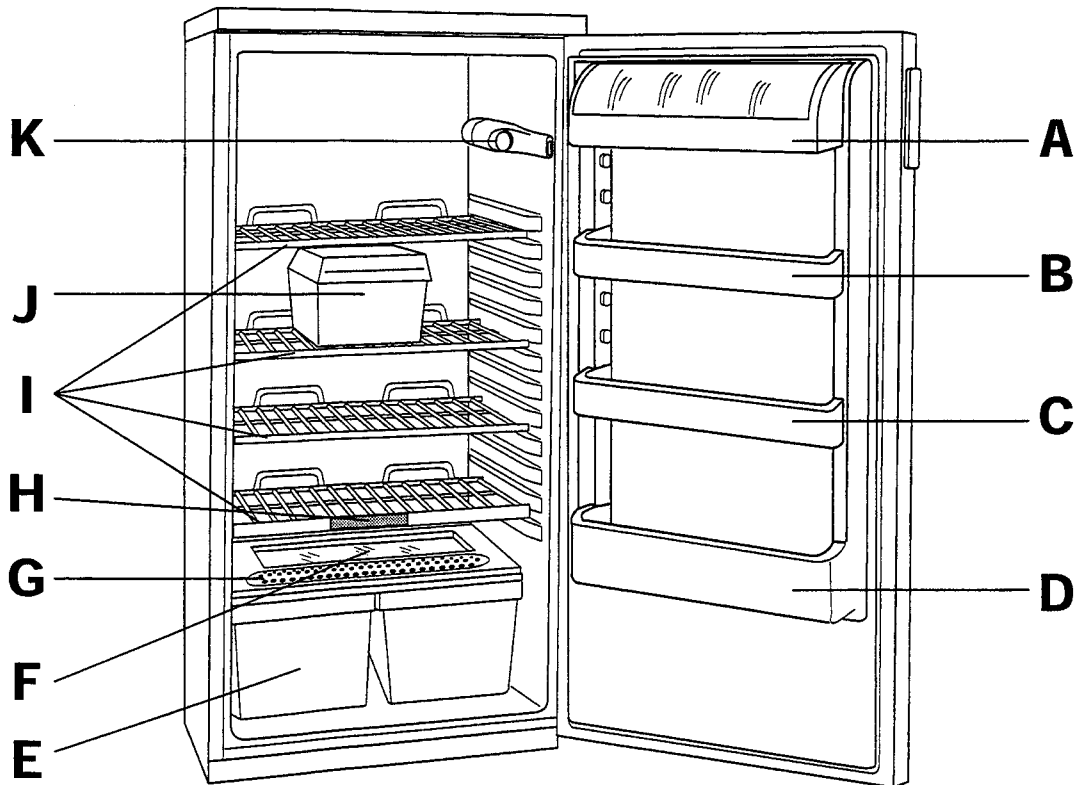

- A - Dairy compartment
- B - Shelf with egg trays
- C - Can storage shelf
- D - Bottle storage shelf
- E - Salad drawers
- F - Glass shelf (for storing fresh meat)
- G - Crisp'n fresh filter
- H - Cool check temperature guide
- I - Storage shelves
- J - Meat box
- K - Thermostat control

**Warning**

IF YOU ARE DISCARDING AN OLD APPLIANCE THAT HAS A LOCK OR CATCH ON THE DOOR, YOU MUST ENSURE THAT IT IS MADE UNUSABLE TO PREVENT YOUNG CHILDREN BEING TRAPPED INSIDE.

Depending upon the position which you choose for your appliance, you may wish to reverse the way in which the door opens. To do this, refer to instructions on "Door reversal directions" paragraph.

Positioning

This appliance is designed to operate in ambient temperatures between 10°C (50°F) and 32°C (90°F). It should be located in a dry atmosphere, out of direct sunlight and away from extreme temperature e.g. not next to a cooker or other sources of direct heat, or in a very cold room e.g. an outhouse, where the temperatures may fall below 10°C (50°F). If these temperatures are exceeded i.e. colder or warmer, then the appliance may not operate correctly.

You should also ensure that air can circulate freely around the back and the top of the cabinet. There must also be at least 100 mm (4") distance between the top of the cabinet and any overhanging kitchen furniture.

There should also be a gap of 25 mm either side of the appliance. Do not obstruct the space underneath. The back of the cabinet may be placed close to the wall but must not touch it. DO NOT install in places with restricted ventilation.

Adjust the level of the appliance by screwing out the adjustable foot, or feet, at the bottom of the cabinet using your fingers or a spanner (see Fig. 1a).

Rear spacers

The plastic bag containing all relevant documentation also contains two spacers to be fitted into special holes in the back of the appliance.

Fit the spacers into the holes, taking care to ensure that the arrow (A) is positioned as shown in Fig. 2. Then turn them through 45° (arrow (A) vertical) until they lock into place.

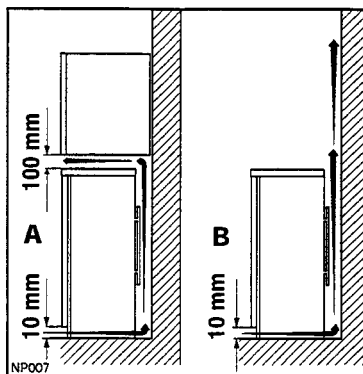
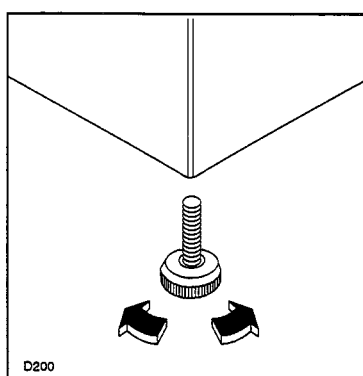
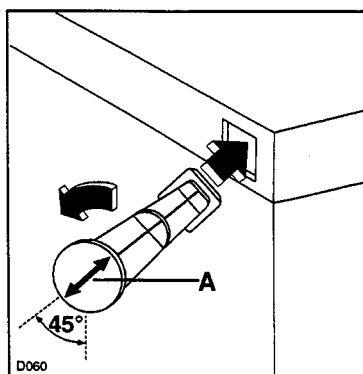
**Fig. 1****Fig. 1a****Fig. 2**

Before using

Remove all securing tapes. Wash inside the appliance with lukewarm water and bicarbonate of soda (5 ml to 0.5 litre of water). Do not use soap or detergent as the smell may linger. Dry thoroughly.

The electrical connections

WARNING: THIS APPLIANCE MUST BE EARTHED.

The manufacturer declines any liability should this safety measure not be observed.

If the plug that is fitted to your appliance is not suitable for your socket outlet, it must be cut off and the appropriate plug fitted.

Remove the fuse from the cut off plug.

The cut off plug should then be disposed of to prevent the hazard of shocks in case it should be plugged into a 13amp socket in another part of your home.

Important

The wires in the mains lead are coloured in accordance with the following code:

Green and Yellow	- Earth
Blue	- Neutral
Brown	- Live

If you fit your own plug, the colours of the wires in the mains lead of your appliance may not correspond with the markings identifying the terminals in your plug, proceed as follows:

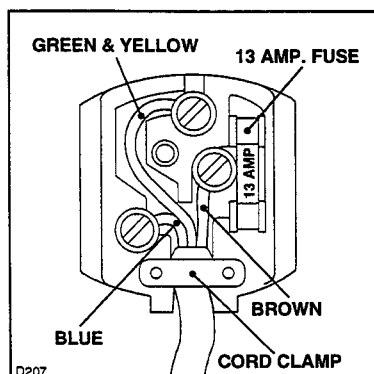

Fig. 3

Connect the Green and Yellow (earth) wire to the terminal in the plug which is marked with the letter «E» or the earth symbol \oplus , or coloured green and yellow.

Connect the blue (neutral) wire to the terminal in the

plug which is marked with the letter «N» or coloured black.

Connect the brown (live) wire to the terminal in the plug which is marked with the letter «L» or coloured red.

The plug moulded onto the lead incorporates a fuse. For replacement, use a 13amp BSI362 fuse. Only ASTA or BSI approved fuses should be used.

The plug must not be used if the fuse cover/carrier is lost. The cover/carrier is indicated by the coloured insert at the base of the plug.

A replacement cover/carrier must be obtained from your local Zanussi Service Force Centre whose address is listed in the Customer Care Booklet which accompanies your instruction manual.

This appliance complies with the E.E.C. Directive No. 87/308 of 2.6.87 relative to radio interference suppression.

 This appliance complies with the following E.E.C. Directives:

- 73/23 EEC of 19.2.73 (Low Voltage Directive) and subsequent modifications;
- 89/336 EEC of 3.5.89 (Electromagnetic Compatibility Directive) and subsequent modifications.

Please ensure that when the appliance is installed it is easily accessible for the engineer in the event of a breakdown.

TECHNICAL SPECIFICATIONS



DIMENSIONS		
	Height	124 cm
	Width	54 cm
	Depth	57 cm

POWER SUPPLY VOLTAGE AND FREQUENCY	220-240 V / 50 Hz
TOTAL POWER ABSORBED	120 W
AVERAGE DAILY UNITS ELECTRICITY*	0.70 kWh

GROSS CAPACITY	230 l
NET CAPACITY	228 l

* This figure is based on standard test results in accordance with European Standard EN153. Actual consumption will depend on how the appliance is used and where it is located.

i Door reversal directions

Before carrying out the operations described below, pull out the mains plug from the wall socket. To carry out this reversal go through the following steps:

Gently lay the fridge on its back with the top held away from the floor by 5-8 cm (2-3 inches) of packing;

Remove bottom hinge (3), pin (1) and screw (2);

Slide the door out from pin (5), unscrew the pin and refit it on the opposite side;

Unscrew the foot on the left hand side and refit it on the opposite side;

Remove the two screws which mask the holes for fixing the hinge from the left hand side;

Refit the door and the lower hinge (turning it 180°), the pin (1) and the screw (2) as shown in Fig. 4a;

Remove the handle (6) and refit it on the opposite side.

Attention

After completion of the door reversibility operation, verify that the door gasket is adherent to the cabinet. If the ambient temperature is cold (i.e. in Winter), the gasket may not fit perfectly to the cabinet. In that case, wait for the natural fitting of the gasket or accelerate this process by heating up the part involved with a normal hairdrier.

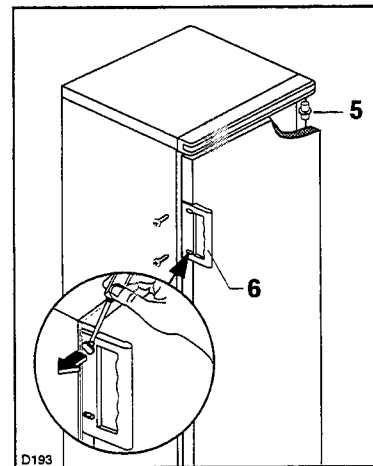

Fig. 4

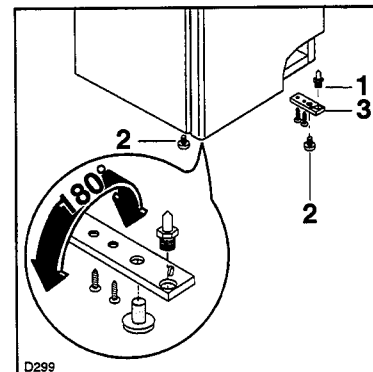

Fig. 4a

Setting the temperature

The temperature inside the refrigerator is regulated by a thermostat with 6 temperature positions and one «OFF» (O) position.

Position 1 = minimum coldness

Position 6 = maximum coldness

Turn the thermostat dial to the required position; **the intermediate position is usually the most suitable (3-4).**

The thermostat setting can vary as the temperature inside the refrigeration compartment depends on the following factors:

- room temperature
- how often the door is opened
- how much food is stored
- position of the appliance

Important

If the fridge is not defrosting correctly, it is possible that because a very low temperature has been selected, the motor is working continuously, which prevents the defrost cycle from operating.

To ensure correct defrosting, a lower number should be selected on the thermostat and you should notice that the motor cuts out from time to time, which is correct.

If you wish to return to a lower temperature, turn the thermostat to a higher number, however you should turn the setting lower occasionally to allow automatic defrosting.



Because of consumer demand, preservatives have been removed from many pre-prepared foods. This together with the changes in shopping habits to a once-a-week shop, mean that safe handling and storage of food is even more important than ever.

The following tips should help you to ensure that the food in your home is in as perfect condition as possible.

- Keep the time between buying chilled food and placing it in your fridge as short as possible. Tests showed that the temperature of 1 litre of orange juice rose to 22°C in an hour between the supermarket and home. It then took 11 hours to get down to 7°C in the refrigerator.
- Keep the refrigerator door closed as much as possible. Remember that warm air is flowing in as you are deciding what to have for tea!
- Do not push food together too much, try to allow air to circulate around each item.
- Cool cooked food as quickly as possible but do NOT place in the refrigerator until cool. (Leave food in a place as cool as possible in order that it can then be placed in the refrigerator as soon as possible).
- Do NOT mix raw and cooked meat, they must be in separate containers. Take care not to let the meat juices drip onto other food. If the meat does drip, remove everything and clean thoroughly.
- Do not store food uncovered.
- Remove suspect food from your refrigerator and clean the interior with a solution of bicarbonate of soda in warm water (5ml to 0.5 litre of water).
- Never allow spillages to dry and harden.
- Store eggs in the egg rack provided in the refrigerator door. Discard any broken or chipped eggs.
- Regularly check the refrigerator door seal to ensure that it is clean and free from bits and pieces.
- Always wash your hands with soapy water and dry them with a clean towel before handling food.
- Keep work surfaces clean and avoid cross contamination by not using the same work surface or knife, without washing them thoroughly in between.
- Use kitchen roll wherever possible for cleaning up food. If you use a dishcloth, be sure to boil it frequently.

i Fresh food refrigeration

To obtain the best performance, do not store warm food or evaporating liquids in the refrigerator; do cover or wrap the food, particularly if it has a strong flavour.

Do not cover the shelves with any protective material, such as paper, cardboard or plastic, which may obstruct the air circulation through them.

To help you use your refrigerator correctly, here are some more useful hints:

Raw meat (beef, pork, lamb & wild fowl): wrap in polythene bags and place on top of the salad crispers.

Meat can only be stored safely in this way for one or two days at the most.

Fruit & vegetables: these should be thoroughly cleaned and placed in the bottom salad crispers.

Butter & cheese: these should be placed in special airtight containers or wrapped in aluminium foil or polythene bags to exclude as much air as possible.

Milk bottles: these should have a cap and should be stored in the bottle rack on the door.

The walls of the refrigerator are equipped with runners so that shelves can be positioned as desired.

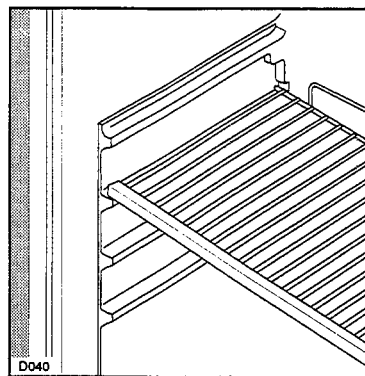

Fig. 5

Positioning the door shelves

To permit storage of food packages of various sizes, the door shelves can be adjusted in height.

To do this proceed as per Fig. 6.

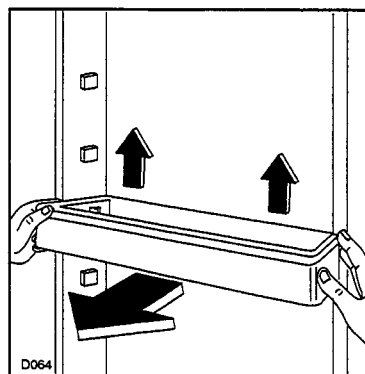

Fig. 6

Use and features of the «CRISP'N FRESH» filter

“Crisp’N Fresh” is the glass shelf on top of the salad crispers which is fitted with special removable green filters.

These filters allow cool air from the fridge to circulate through the drawers but help prevent moisture loss. By retaining moisture in foods such as fresh fruit, vegetables and salad they are kept fresher for longer.

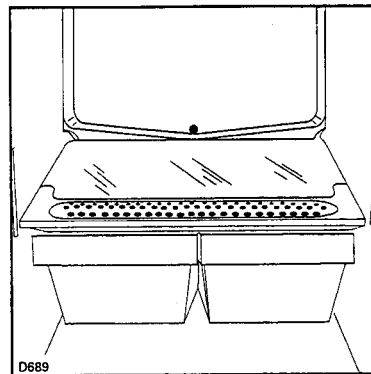

Fig. 7

Cleaning the filter

The filter is held by two small support frames which press into position and are therefore easily removed for cleaning. To do this, turn the glass shelf upside down and release the frames as shown in Fig. 8. The filters and the glass cover can be washed gently in warm soapy water, they should not be put in the dishwasher.

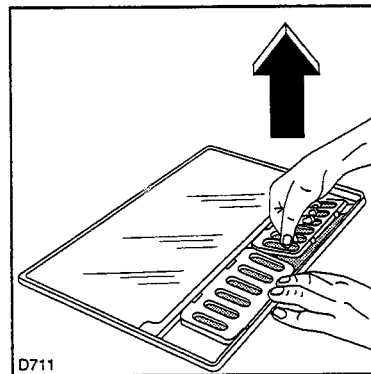

Fig. 8

Cool check temperature guide

This model has a cool check temperature guide fitted to a shelf in the fridge compartment. The guide is designed to show whether the fridge is operating at safe temperatures for all food types. The guide consists of a temperature sensitive strip sealed in the shelf trim.

When the fridge is operating at the safe temperature to store food, the guide will appear black. If the temperature in the fridges rises the guide will show the words TOO WARM. The temperature in the fridge may rise if the door has just been opened, the fridge has just been loaded with shopping or if the room temperature is higher than normal. See “Everyday use of the temperature guide” for further information.

The shelf with Cool Check temperature guide must be placed in the fridge according to the instructions located on the fridge wall and always ensure the guide is at the front.

When cleaning the shelf take care not to immerse the guide in water and wipe any spills from the holder quickly.



Important

The guide is only suitable for use in the model supplied and accurate temperature guidance cannot be guaranteed if transferred to other appliances. The guide will not work in the freezer compartment.

Starting the appliance

Check that the shelf with the Cool Check is positioned correctly (as described previously). Close the door and leave the appliance overnight to allow the temperature to reach a safe level.

If after waiting overnight the temperature guide still shows TOO WARM, adjust the thermostat to a higher number, close the door and allow to stand overnight. A higher thermostat setting may be required to keep the fridge temperature at the safe storage level during warmer weather.

For more information on starting your appliance, see “Operation”.

Everyday use of the cool check temperature guide

During everyday use a fridge door is opened many times and as a result temperature fluctuation may occur. A Zanussi fridge is designed to cope with any changes in temperature but under certain conditions the temperature guide in the appliance may show TOO WARM.

What to do if the Cool Check temperature guide shows TOO WARM

The Cool Check guide may show TOO WARM if:

1. The fridge is switched off.

ACTION: Start the appliance in accordance with the instructions.

2. The fridge door has recently been opened or is left open for more than approximately one minute.

ACTION: As mentioned before the temperature guide is sensitive to changes in fridge temperature and opening the fridge door for prolonged periods may cause the guide to show TOO WARM. This should not cause concern as such fluctuations in temperature do not generally affect the safe storage of food.

Leave the fridge door closed for as long as possible so the temperature returns to a safe level, the guide should then appear black.

3. The fridge has been loaded with fresh shopping.

ACTION: When fresh shopping or additional quantities of food are placed in the fridge, the temperature may rise and cause the guide to show TOO WARM.

Do not adjust the thermostat as the time taken for the guide to appear black will depend on the quantity and the temperature of food introduced.

4. The fridge temperature is above the recommended maximum for the safe storage of all food types.

ACTION: To lower the fridge temperature, adjust the thermostat, then leave the appliance overnight before checking the guide again.

5. If the guide is still showing TOO WARM, adjust the thermostat again, to a colder setting, and leave the appliance overnight before checking the guide again.

Defrosting

The refrigerator automatically defrosts every time the compressor stops. The water is discharged, via the pipe, into a tray located at the back of the appliance above the compressor, where it evaporates.



Important

To avoid defrost water overflowing into the fridge, periodically clean the water discharge hole in the centre of the V shaped drip collector at the back of the refrigerator compartment behind the fruit and vegetable drawer. Use the defrost cleaner provided which you will find already inserted into the discharge hole (Fig. 9).

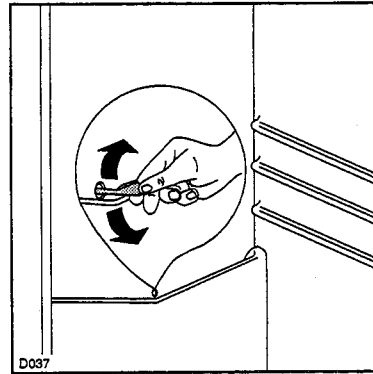

Fig. 9

Before any maintenance or cleaning work is carried out, **DISCONNECT** the appliance from the **ELECTRICITY** supply.

Internal cleaning

Clean the inside and accessories with warm water and bicarbonate of soda (5ml to 0.5 litre of water). Rinse and dry thoroughly.

! NEVER USE DETERGENTS, ABRASIVE POWDERS, HIGHLY PERFUMED CLEANING PRODUCTS OR WAX POLISHES, TO CLEAN THE INTERIOR AS THESE WILL DAMAGE THE SURFACE AND LEAVE A STRONG SMELL.

Clean the drain hole of the water trough at regular intervals and make sure that the drain hole is never obstructed, so that the defrost water may flow freely.

External cleaning

Wash the outer cabinet with warm soapy water. Do **NOT** use abrasive products.

Once or twice a year dust the condenser (black grill) and the compressor at the back of the appliance, with a brush or vacuum cleaner, see Fig. 10.

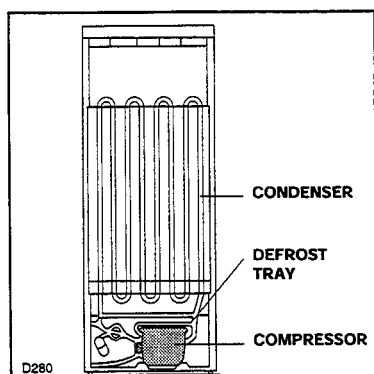

Fig. 10

You **MUST** ensure that the appliance is switched **OFF**. An accumulation of dust will affect the performance of the appliance and cause excessive electricity consumption.

When the appliance is not in use

When the appliance is not in use for long periods, disconnect from the electricity supply, empty all foods and clean the appliance, leaving the doors ajar to prevent unpleasant smells.

Interior light

The light bulb inside the refrigerator compartment can be reached as follows:

- unscrew the light cover securing screws;
- unhook the moving part by pressing it as shown in the figure.

If the door is open and the light does not come on, check that the bulb is properly screwed in; if it still does not work, replace the bulb with one of the same power.

The maximum rating is shown on the light cover.

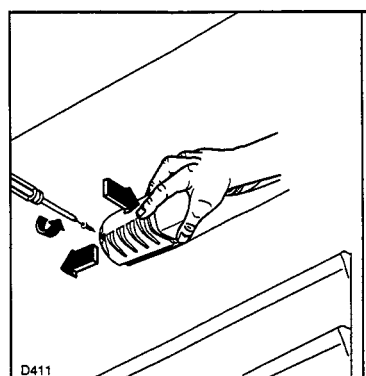

Fig. 11

Replace the light cover by sliding it into its original position and replacing the screw.

WHAT HAPPENS IF SOMETHING GOES WRONG?



Before contacting your local Zanussi Service Centre, check the following points:

The appliance does not work...	<p>Check that:</p> <ul style="list-style-type: none"> ■ There is power at the socket. ■ Ensure that there is not a power cut by checking the household lights. ■ The fuse has not blown. ■ The air circulation passages are not covered. ■ The thermostat dial is in the correct position.
Vibration or abnormal noises...	<ul style="list-style-type: none"> ■ You may hear faint gurgling or bubbling sounds when the refrigerant is pumped through the coils of tubing at the rear, to the cooling plate/evaporator. When the compressor is on, the refrigerant is being pumped round, and you will hear a whirring or pulsating noise from the compressor. A thermostat controls the compressor, and you will hear a faint "click" when the thermostat cuts in and out.
Traces of water on the bottom of the fridge compartment...	<ul style="list-style-type: none"> ■ The defrosting water discharge hole is not obstructed.
The light does not come on...	<ul style="list-style-type: none"> ■ The bulb is fitted correctly. ■ Replace the bulb if it has blown.
Fridge does not defrost...	<ul style="list-style-type: none"> ■ The thermostat setting is not too high (see page 10).
Other points to check...	<ul style="list-style-type: none"> ■ Have you turned the thermostat to the correct setting? ■ Have door been left open causing the temperature to rise?

If, after the above checks, there is still a fault, call your local Zanussi Service Centre, whose address can be found in the accompanying Customer Care Booklet, and can also be found in your local telephone directory under «Z». Please make sure you give the model and serial number of the appliance. This information can be found on the rating plate inside the fridge compartment on the left side behind the vegetable drawer, or on the guarantee certificate.

Original spare parts can be purchased from Zanussi Service Centres.

In-guarantee customers should ensure that the above checks have been made as the engineer will make a charge if the fault is not a mechanical or electrical breakdown.

Please note that proof of purchase is required for any in-guarantee service calls.

Before contacting your local Zanussi Service Centre, make a note of the model and serial number. This information can be found on the rating plate situated inside the cabinet behind the bottom fridge/freezer drawer.

SERVICE DETAILS - ADHESIVE LABEL

When you return your guarantee card to Zanussi Ltd., you will receive an Appliance Guarantee and Maintenance Record Card together with an adhesive label. The label can be stuck to the machine or adjacent furniture.

Zanussi standard guarantee conditions

This guarantee is in addition to your statutory and other legal rights.

We, Zanussi Ltd., undertake that if, within twelve months of the date of the purchase, this ZANUSSI appliance or any part thereof is proved to be defective by reason only of faulty workmanship or materials, we will, at our option, repair or replace the same **FREE OF ANY CHARGE** for labour, materials or carriage on condition that:

- The appliance has been correctly installed and used only on the electricity supply stated on the rating plate.
- The appliance has been used for normal domestic purposes only, and in accordance with the manufacturer's operating and maintenance instructions.
- The appliance has not been serviced, maintained, repaired, taken apart or tampered with by any person not authorised by us.

All service work under this guarantee must be undertaken by a Zanussi Service Centre.

Home visits are made between **8.30am** and **5.30pm** Monday to Friday. Visits may be available outside these hours in which case a **premium** will be charged.

Any appliance or defective part replaced shall become our property.

Exclusions

This guarantee does not cover:

- Damage or calls resulting from transportation, improper use or neglect, the replacement of any light bulbs or removable parts of glass or plastic.
- Costs incurred for calls to put right machines improperly installed or calls to machines outside the United Kingdom.
- Appliances found to be in use within a commercial environment, plus those which are the subject of rental agreements.
- Products of Zanussi manufacture which are NOT marketed by Zanussi Ltd.
- EU Countries - The standard guarantee is applicable but is subject to the owner's responsibility and cost to ensure the appliance meets the standards set by the country to which the product is taken. The Zanussi Company in the country concerned will be pleased to advise further. Sight of your purchase receipt will be required by them.



