

SX4750 Swinging Bucket Rotor



**Used in Beckman Coulter
Allegra® X-12 Series
and Allegra X-15R Centrifuges**



SAFETY NOTICE

This safety notice summarizes information basic to the safe use of the rotor described in this manual. The international symbol displayed above is a reminder to the user that all safety instructions should be read and understood before operation or maintenance of this equipment is attempted. When you see the symbol on other pages of this publication, pay special attention to the safety information presented. Observance of safety precautions will also help to avoid actions that could damage or adversely affect the performance of the rotor.



Handle body fluids with care because they can transmit disease. No known test offers complete assurance that such fluids are free of micro-organisms. Some of the most virulent—Hepatitis (B and C) viruses, HIV (I–V), atypical mycobacteria, and certain systemic fungi—further emphasize the need for aerosol protection. Handle other infectious samples according to good laboratory procedures and methods to prevent spread of disease. Because spills may generate aerosols, observe proper safety precautions for aerosol containment. Do not run toxic, pathogenic, or radioactive materials in this rotor without taking appropriate safety precautions. Biosafe containment should be used when Risk Group II materials (as identified in the *World Health Organization Laboratory Biosafety Manual*) are handled; materials of a higher group require more than one level of protection.



This rotor was developed, manufactured, and tested for safety and reliability as part of a Beckman Coulter centrifuge/rotor system. Its safety or reliability cannot be assured if used in a centrifuge not of Beckman Coulter's manufacture or in a Beckman Coulter centrifuge that has been modified without Beckman Coulter's approval.



Although rotor components and accessories made by other manufacturers may fit in the SX4750 rotor, their safety in this rotor cannot be ascertained by Beckman Coulter. Use of other manufacturers' components or accessories in the SX4750 rotor may void the rotor warranty and should be prohibited by your laboratory safety officer. Only the components and accessories listed in this publication should be used in this rotor.



Attach all four buckets or carriers, loaded or empty, to the rotor for every run. Make sure that filled containers are loaded symmetrically into the rotor and that opposing containers are filled to the same level with liquid of the same density.



The rotor and accessories are not designed for use with materials capable of developing flammable or explosive vapors. Do not centrifuge such materials in nor handle or store them near the ultracentrifuge.



If disassembly reveals evidence of leakage, you should assume that some fluid escaped the rotor. Apply appropriate decontamination procedures to the centrifuge and accessories.



Never exceed the maximum rated speed of the rotor and labware in use. Refer to the section on RUN SPEEDS, and derate the run speed as appropriate.



Do not use sharp tools on the rotor that could cause scratches in the rotor surface. Corrosion begins in scratches and may open fissures in the rotor with continued use.

SX4750 ROTOR

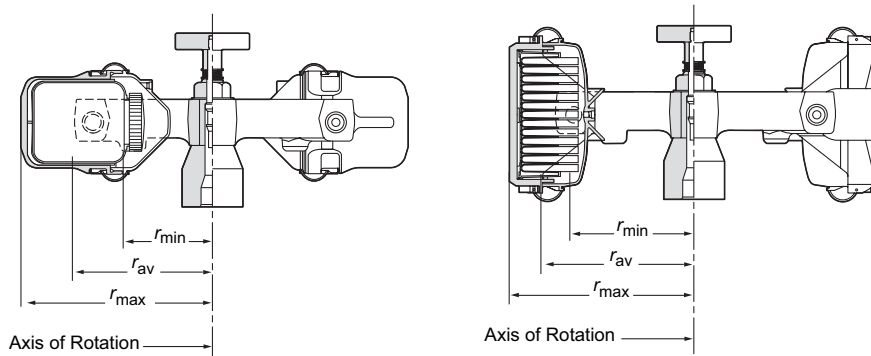

SPECIFICATIONS

Maximum speed

Allegra X-15R (tube-and-bottle buckets)	4750 rpm
Allegra X-15R (multiwell-plate carriers)	4450 rpm
Allegra X-12 series (all buckets).	3750 rpm
Critical speed range*.	580 to 720 rpm
Maximum solution density	1.2 g/mL

Relative Centrifugal Field[†] at maximum speed

using tube-and-bottle buckets ($r_{\max} = 207.8$ mm)	$5250 \times g^{\ddagger}$
using multiwell-plate carriers ($r_{\max} = 183.2$ mm)	$4060 \times g^{\ddagger}$

Conditions requiring speed reductions see SPEED DERATING

Number of buckets/carriers 4

Available tubes and bottles see Table 2

Maximum load allowed in each tube-and-bottle bucket at
rated speed (excluding weight of bucket and cover) 1000 grams

Maximum load allowed in each multiwell-plate carrier
at rated speed (excluding weight of carrier and cover) 360 grams

Total maximum allowable imbalance of opposing loads 6 grams

Maximum rotor capacity 3 liters

Approximate acceleration time 80 seconds

Approximate deceleration time 80 seconds

Weight of fully loaded rotor (buckets with covers). 13.3 kg (29.3 lb)

Rotor yoke material. stainless steel

Bucket and carrier material anodized aluminum

* The critical speed range is the range of speeds over which the rotor shifts so as to rotate about its center of mass. Passing through the critical speed range is characterized by some vibration. A short-duration second critical may occur at about 1300 rpm.

[†] Relative Centrifugal Field (RCF) is the ratio of the centrifugal acceleration at a specified radius and speed ($r\omega^2$) to the standard acceleration of gravity (g) according to the following formula:

$$RCF = \frac{r\omega^2}{g}$$

where r is the radius in millimeters, ω is the angular velocity in radians per second ($2\pi \text{ RPM} / 60$), and g is the standard acceleration of gravity (9807 mm/s^2). After substitution:

$$RCF = 1.12 r \left(\frac{\text{RPM}}{1000} \right)^2$$

[‡] RCF inside buckets is $5095 \times g$ (tube-and-bottle buckets— r_{\max} 201.6 mm) or $3919 \times g$ (multiwell plate carriers— r_{\max} 176.7 mm).

DESCRIPTION

This rotor has been manufactured in an ISO 9001 or 13485 facility for use with the specified Beckman Coulter centrifuges.

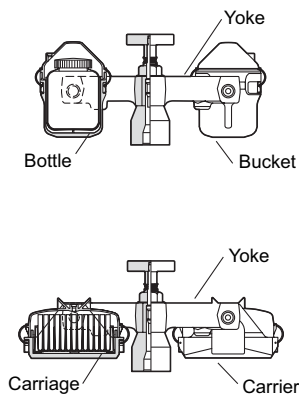

The SX4750, rated for 4750 rpm (3750 rpm in an Allegra X-12 series centrifuge), is a four-place swinging bucket rotor used in Beckman Coulter Allegra X-12 series and Allegra X-15R benchtop centrifuges. The rotor buckets carry adapters that allow centrifugation of a wide range of tube and bottle sizes (from 1.5 mL reaction vials to 750-mL bottles) or single- to quad-pack blood bags, as well as multiwell plates in carriers. Special adapters are also available that allow centrifugation of Corning¹ 75-cm² and 25-cm² cell culture flasks. The rotor develops centrifugal forces that are suitable for rapidly sedimenting protein precipitates, large particles, cells, and cell debris. Figure 1 shows the rotor and accessories.

The rotor yoke is made of stainless steel. Black-anodized aluminum buckets and carriers can be run by placing them over pivot pins on the arms of the yoke; they swing out to horizontal position during centrifugation. Transparent covers made of a high-impact plastic are available for the rotor buckets and carriers. Covers have been tested² to demonstrate containment of microbiological aerosols under normal conditions of the associated Beckman Coulter centrifuge when used



Figure 1. The SX4750 Rotor and Accessories

¹ Corning is a trademark of Corning Incorporated.

² Validation of microbiological containment was done at an independent third-party testing facility (CAMR, Porton Down, UK, or USAMRIID, Ft. Detrick, MD, U.S.A.). Improper use or maintenance may affect seal integrity and thus containment.

and maintained as instructed. The covers, which are held in place by attached latch assemblies, will contain liquids and broken tube particles, reducing the need to clean the centrifuge chamber and allowing you to take appropriate precautions before opening the covers in the event of tube breakage. A captive tie-down device is used to secure the rotor to the drive shaft during centrifugation.

The centrifuge identifies the rotor during the run by means of a magnetic sensor system in the centrifuge rotor chamber and magnets imbedded in the rotor. The overspeed system ensures that the rotor does not exceed its permitted speed.

Refer to the Warranty at the back of this manual for warranty information.

BUCKETS AND ACCESSORIES

Several types of labware can be run in the buckets, depending on your application.

Modular Disk Adapters

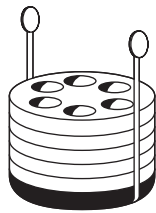

Tubes are supported in modular disk adapters, which can also serve as tube racks in the laboratory. The adapter disks are color coded by the tube size they accommodate (see Table 1); the number of disks used in an adapter assembly depends upon the length of tubes used. A tube decanter is available to hold either 10-mm or 12-mm tubes securely in the blue adapter, allowing all the tubes to be decanted at once. Additionally, 1.5-mL Microfuge[®] tubes can be run using a special plate that fits on top of the blue adapter. Both of these accessories are described in Table 1. Beckman Coulter tubes and bottles available for use in the rotor buckets are described in Table 2.

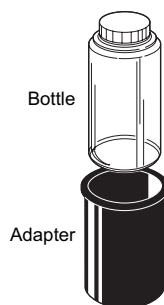

Bottle Adapters

Bottles are supported in polypropylene adapters that fit inside the rotor buckets. The adapters are ribbed for strength and accommodate three bottle sizes, including one conical bottle (see Table 1).

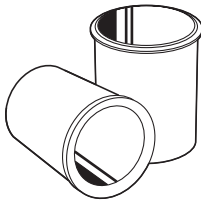

Blood Bag Cups

Polypropylene cups provide support for blood bags in the rotor buckets. Blood bag cups are available in two sizes: one for single- or double-pack bags, and one for triple- or quad-pack bags (see Table 1).

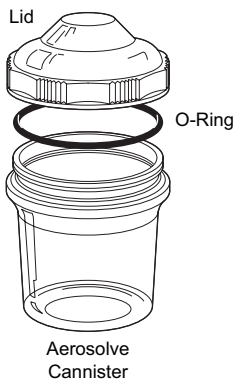

Aerosolve Cannisters

Aerosolve cannisters, designed to contain aerosol leakage and liquid spills, can be used in the SX4750 buckets when this additional containment is required. The cannister was tested³ to demonstrate containment of microbiological aerosols under normal operating conditions of the associated Beckman Coulter centrifuge, when used and maintained as instructed. Aerosolve cannisters hold a variety of tube sizes in racks, or they can be used as 500-mL wide-mouth bottles.



CAUTION

Do not run chloroformed samples in Aerosolve cannisters. Chloroform vapors can damage the cannister material.

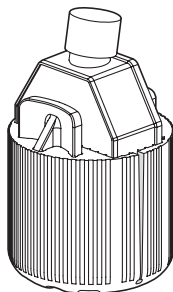

75-cm² Flask Adapter

Cell Culture Flask Adapters

Specially designed EPDM (ethylene propylene) adapters can be used to centrifuge Corning 25-cm² (two per bucket) or 75-cm² (one per bucket) canted-neck cell culture flasks. Using these adapters, the separation and concentration step of the cell culturing process can be accomplished in the flask. Elimination of the need to transfer cultures into tubes for centrifugation and back into flasks minimizes the risk of contamination, as well as saving time and labware.

³ Validation of microbiological containment was done at an independent third-party testing facility (CAMR, Porton Down, UK, or USAMRIID, Ft. Detrick, MD, U.S.A.). Improper use or maintenance may affect seal integrity and thus containment.

Multiwell-Plate Carriages

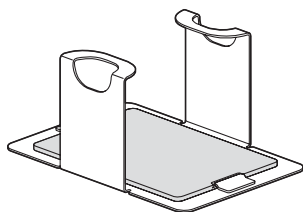

Used in the multiwell-plate carriers to facilitate loading and unloading and to provide support to the labware during centrifugation, each multiwell-plate carriage can hold up to four stacked multiwell plates (not to exceed 55.9 mm/2.2 in. in depth) or one deep-well plate. Each carrier can also carry a 96-well kit for high-throughput processing (such as DNA or RNA kit). A polypropylene pad provides support for the labware.

RUN PREPARATION

Specific information about the SX4750 rotor is given here. Information about the use and care of the centrifuge is contained in the centrifuge manual, which should be used together with this manual for complete rotor and centrifuge operation.

NOTE

Although rotor components and accessories made by other manufacturers may fit in the SX4750 rotor, their safety in this rotor cannot be ascertained by Beckman Coulter. Use of other manufacturers' components or accessories in the SX4750 rotor may void the rotor warranty and should be prohibited by your laboratory safety officer. Only the components and accessories listed in this publication should be used in this rotor.

PRERUN SAFETY CHECKS



Read the SAFETY NOTICE page at the front of this manual before using the rotor.

1. Make sure that the rotor yoke, buckets and/or carriers, and covers are clean and show no signs of corrosion or cracking. If any evidence of damage is present, do not centrifuge the rotor.

2. Check the chemical compatibilities of all materials used. Refer to *Chemical Resistances* (publication IN-175).
3. Verify that the tubes, bottles, and accessories being used are listed in Tables 1 through 3.

INSTALLING THE ROTOR YOKE

NOTE

Before the first use of a new rotor, attach the tie-down T-bar (369716) to the rotor yoke. Screw it down as far as possible.

1. Before installing the yoke in the centrifuge, lightly lubricate the drive hole with a lubricant such as Spinkote (306812).

CAUTION

Never drop the rotor yoke onto the centrifuge drive shaft. The drive shaft can be damaged if the rotor is forced sideways or dropped onto it.

2. Carefully lower the yoke straight down onto the centrifuge drive shaft. Be sure the yoke is properly seated on the shaft.
3. Turn the tie-down T-bar to the right (clockwise) to tighten the yoke firmly on the drive shaft.

NOTE

If the rotor yoke is left in the centrifuge between runs, before each run make sure it is properly seated on the drive shaft, and that the T-bar is tight.

LOADING THE BUCKETS

For runs at other than room temperature, refrigerate or warm the rotor and precool the centrifuge beforehand for fast equilibration.



WARNING

Handle body fluids with care because they can transmit disease. No known test offers complete assurance that such fluids are free of micro-organisms. Some of the most virulent—Hepatitis (B and C) viruses, HIV (I–V), atypical mycobacteria, and certain systemic fungi—further emphasize the need for aerosol protection. Handle other infectious samples according to good laboratory procedures and methods to prevent spread of disease. Because spills may generate aerosols, observe proper safety precautions for aerosol containment. Do not run toxic, pathogenic, or other hazardous materials in this rotor without taking all appropriate safety precautions. Biosafe containment should be used when Risk Group II materials (as identified in the World Health Organization *Laboratory Biosafety Manual*) are handled; materials of a higher group require more than one level of protection.

SYMMETRICAL AND BALANCED LOADING

Beckman Coulter supplies buckets and carriers in weight-matched sets to make balancing easier (the weight and retirement date are marked on each bucket and carrier). Modular disk adapters are also sold in weight-matched sets. However, there are variances in weight between sets, as well as variance in weight between previously purchased adapters. To prevent accidental imbalance it is important to keep matched sets of buckets as well as matched sets of adapters together and to weigh other adapters to be sure they are approximately the same. Marking matched adapter sets will help you keep them together.

NOTE

The light purple 500-mL adapters (349945) replace the previous tan adapters. There is a weight difference between the old tan adapters and the current purple adapters. If you run a mix of the purple and tan adapters, be sure to run matching colors in opposing positions or rotor imbalance could occur.

To ensure optimal performance and stability, the rotor must be loaded symmetrically. Two factors affect symmetric loading:

- The buckets or carriers must be loaded symmetrically with respect to their pivotal axes.
- The rotor should be loaded symmetrically with respect to its center of rotation.

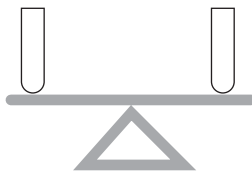

For best results, load opposing buckets or carriers with the same type of labware containing the same amounts of fluid of equal density. Additionally, opposing buckets or carriers and their contents should weigh approximately the same (within 6 grams). Do not exceed the rated maximum load for buckets (1000 grams each for tube-and-bottle buckets; 360 grams each for multiwell-plate carriers).

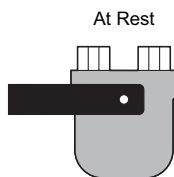

It is not necessary to completely fill all tubes⁴ or positions in buckets; however, partially filled buckets must be balanced with respect to the bucket pivotal axis (see Figure 2). In multitube adapters, each tube should be placed so that its weight is balanced by a tube in a diametrically opposite position across the pivotal axis in the same adapter. Adapters placed in opposing buckets should also be filled the same way.

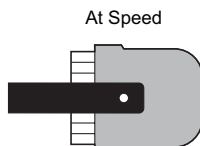

In multiwell plate carriers, samples should be loaded into the wells symmetrically with respect to the pivotal axis of the bucket, and opposing carriers should contain similar loads.

⁴ Fill tubes at least half full. Speed reduction may be required for fill volumes below 75 percent.

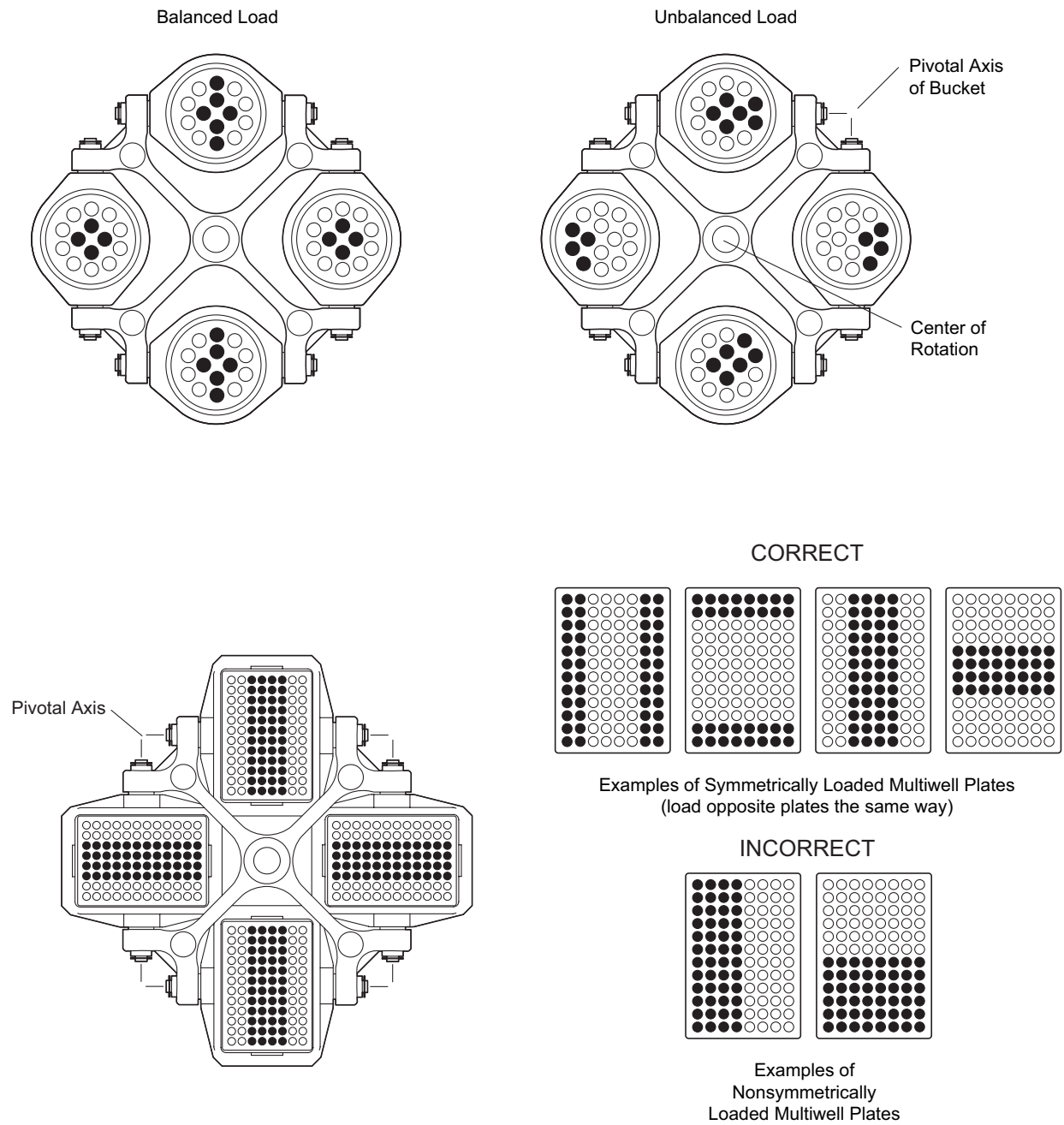

Figure 2. Examples of Correctly and Incorrectly Loaded Buckets and Carriers. Contents of opposing buckets must be the same and each bucket must be balanced on its pivotal axis.

USING TUBE-AND-BOTTLE BUCKETS

Whether you are running tubes, bottles, cell culture flasks, or blood bags, you must load the buckets symmetrically around the center of rotation and each bucket must be loaded symmetrically with respect to its pivotal axis (see SYMMETRICAL AND BALANCED LOADING, above).



CAUTION

Buckets are designed to be used only with modular disk adapters, bottle adapters, cell culture flask adapters, Aerosolve cannisters, and blood bag cups. Do not pour samples directly into buckets, bottle sleeves, or blood bag cups. Do not load bottles, cell culture flasks, or tubes directly into the buckets. Do not use labware that is not specified for use in this rotor.

You can load buckets before or after they are installed on the rotor yoke. In either case, we recommend filling the appropriate labware first and then loading the labware into the buckets.

Using Tubes

Assembling Modular Disk Adapters

Refer to Table 1 to determine which color adapter is required for the tubes you are using and the number of disks needed to support the length of the tubes.

1. Select the appropriate adapter base (from Table 1) and attach a bail to it (see Figure 3).
2. Position one of the disks so that its grooves are aligned with the bail. Push the disk down until the bail snaps into the grooves.
3. Add more disks in this way until the height of the assembly is nearly as tall as the tubes you will be using. (If the height of the disks is very tall, you may have to push the bail into the grooves of the top disks by hand.) Remove or add disks to the bail to accommodate shorter or longer tubes. If the tubes fit too snugly in the adapter's rubber base, apply a light film of powder, such as talcum powder, to prevent the tubes from sticking.

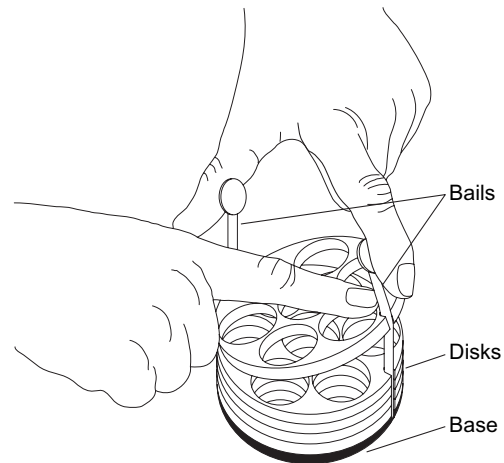

Figure 3. Assembling a Modular Disk Adapter

Loading Tubes in Adapters

When placing tubes in modular disk adapters, it is important to make sure that they will not contact the rotor yoke during a run.

- One way to do this is to place empty tubes in an adapter, place the adapter in a bucket on the rotor yoke, and manually swing the bucket to the horizontal position, making sure that all tubes clear the yoke.
- Another method is to place the adapter in a bucket and position a bucket cover over the tubes, checking that tubes do not touch the cover.

If all positions in an adapter are not filled, load the adapter symmetrically with respect to its pivotal axis (see SYMMETRICAL AND BALANCED LOADING, above).

Loading Adapters in the Buckets

After placing tubes in the disk adapters, lower the adapters into the buckets so that the bails line up with the rotor pivot pins. If only two loaded adapters are run, place them in opposing buckets. The other two buckets should contain empty modular disk adapters (do not centrifuge empty cell culture flask adapters) to prevent imbalance. (See SYMMETRICAL AND BALANCED LOADING, above.)

Using Bottles in Adapters

Load bottles into their appropriate adapters (see Table 1), then place the filled adapters in the rotor buckets. If only two bottles are run, place them in opposite buckets. Make sure the other two buckets contain at least a minimal “blank” load (such as empty modular disk adapters) to prevent rotor imbalance. If modular disk adapters are not available, use two water-filled bottles in adapters to balance the load. (See SYMMETRICAL AND BALANCED LOADING, above.)

Using Aerosolve Cannisters



CAUTION

Do not run chloroformed samples in Aerosolve cannisters. Chloroform vapors can damage the cannister material.

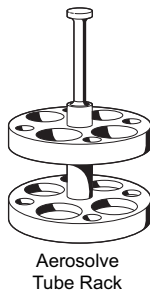

Aerosolve
Tube Rack

Aerosolve cannisters can be used as wide-mouth bottles or with tubes in racks that are specially designed to fit in the cannisters. Table 1 lists the Aerosolve tube racks and the number and sizes of tubes they accommodate. Pads (361269) must be placed beneath the cannisters in the buckets to provide support and prevent the cannisters from being damaged during centrifugation. These pads are included in the Aerosolve cannister kits (359232). Bucket covers cannot be used with Aerosolve cannisters.

Using Blood Bag Cups



NOTE

This rotor is suitable for obtaining cell-free plasma or for cell packing.

The yellow 90-mm cup (356856) accommodates up to two single bags or one double pack; the orange 97-mm cup (356857) supports either one triple or one quad pack. *Do not pour liquid directly into blood bag cups.* Fit blood bags into cups before loading the cups into the rotor buckets. Load the blood bag cups as follows:

1. Load the bags as far down into the cups as possible.

NOTE

Make sure the bags stay as vertical as possible, with no folds at the top or corners. If folds are present, blood cells could remain in the folds and then mix with the plasma when the bag is removed.

2. Sandwich the tubing between the blood bag and any transfer packs (see Figure 4).

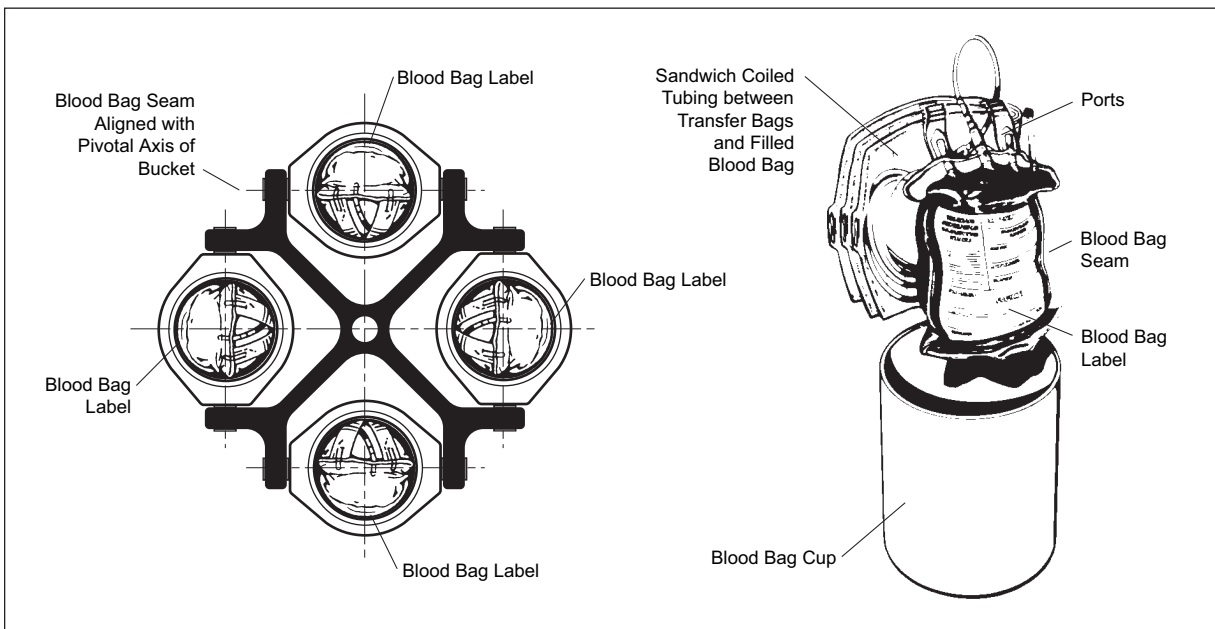

Figure 4. Blood Bag Loading Procedures

3. Make sure the loaded blood bag cups opposite each other on the rotor yoke are approximately the same weight (within 1 gram). Soft, pliable balancing pads that will not puncture blood bags (see the SUPPLY LIST) can be used to maintain weight balance, if necessary.
4. Place loaded cups into rotor buckets. To reduce the possibility of bag breakage, align the blood bag seam with the rotor pivot pins (see Figure 4) with the label facing out.

5. Place bucket covers on rotor buckets to prevent blood bags or tubing from contacting the rotor yoke during centrifugation.



CAUTION

If bucket covers are not used, make sure the superstructure of the blood bag protruding from the cup does not inhibit the bucket from reaching its horizontal position. If it does, remove the cup from the rotor and reposition the blood bag so that it seats further into the cup. Allowing the blood bags to contact the rotor yoke during centrifugation can cause the bucket to come off the pivot pins and can seriously damage both the rotor and the centrifuge.

If only two filled cups are run, place them in opposing buckets. The other two buckets should contain similar “blank” loads to prevent imbalance (either empty modular disk adapters or water-filled blood bags in cups).

Using Cell Culture Flask Adapters

Refer to publication GX-TB-007 for 25-cm² flask adapter information or GX-TB-006 for 75-cm² flask adapters. (These publications are supplied with the respective adapters.)

NOTE

A dry release agent is used to facilitate removal of cell culture flask adapters from buckets following centrifugation. To avoid compromising the bucket/cover bioseal, the release agent should not be allowed on the bucket O-ring. When running cell culture flasks, use the provided adapter to apply the dry release agent to the bucket cavity and take care to avoid contamination of the O-ring.

Using Bucket Covers

NOTE

Because of the shape of the covers, 130-mm tubes can be used *only* in the center cavities of the adapters when covers are used.

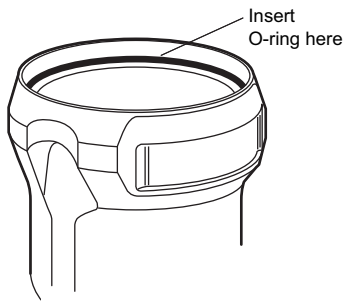

Install the cover as follows:

1. Make sure that the bucket and the bucket cover surfaces are clean, dry, and undamaged.
2. Make sure that the O-ring (961648) is in good condition and lightly coated with silicone vacuum grease (335148). Place the O-ring on the ledge inside the bucket.
3. Place the cover on the bucket with the latches perpendicular to the pin sockets.
4. Snap the latches down and secure them under the bucket rim.

Loading Buckets Onto the Yoke

1. Attach each bucket to the yoke by aligning the grooves in the bucket sides with the pivot pins, then sliding the buckets down until the pivot pins are seated in the bucket pockets.



CAUTION

Attach all four buckets, loaded or empty, to the rotor yoke. If only two buckets are filled, place them in opposite positions on the yoke. All four positions must contain buckets or carriers during a run. Never run the rotor with only two positions filled.

2. Gently swing the buckets to ensure that they are properly seated on the pivot pins.

USING MULTIWELL-PLATE CARRIERS

If only two filled multiwell-plate carriers are run, install them opposite each other in the rotor and run two additional carriers or buckets (they can be empty) to prevent rotor imbalance.

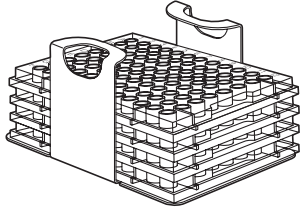

1. Insert the filled plate(s) into the carriage. If using two or three Beckman Coulter plates per carrier, place a 96-well cap strip (see Table 3) between the plates to prevent breakage during centrifugation.

NOTE

Up to three Beckman Coulter plates, separated by cap strips, can be run per carrier at maximum multiwell-plate speeds. If running four Beckman Coulter plates, cap strips cannot be used due to height limitations; reduce run speed to 2700 rpm. Observe manufacturer's run speed and stacking limitations if using other manufacturers' multiwell plates.⁵ RCF and stacking limitations vary widely between manufacturers—pretest other manufacturers' plates using water instead of valuable sample.

2. Grasp the carriage by the handles and lower it into the carrier.
3. Make sure that carrier cover gaskets are in good condition and secured to the covers.
4. Put covers on the carriers with the latches perpendicular to the pin sockets. Snap the latches down and secure them under the carrier rim.
5. Attach each carrier to the yoke by aligning the grooves in the sides with the pivot pins, then sliding the carrier down until the pivot pins are seated in the pin pockets.

⁵ See Table 4 on page 28 for plates recommended for use in stacks of four at maximum speed.

**CAUTION**

All four positions must contain buckets or carriers during a run. Never run the rotor with only two positions filled. If two tube-and-bottle buckets and two multiwell-plate carriers are run, position the similar buckets opposite each other. Select multiwell-plate carrier speed when running mixed sets.

6. Gently swing the carriers to ensure that they are properly seated on the pivot pins.

OPERATION

1. Refer to the instrument instruction manual for centrifuge operation.
2. See RUN SPEEDS, page 20, for information about speed limitations.

REMOVAL AND SAMPLE RECOVERY**CAUTION**

If disassembly reveals evidence of leakage, you should assume that some fluid escaped the rotor. Apply appropriate decontamination procedures to the centrifuge and accessories.

1. Remove the buckets or carriers from the centrifuge.
2. Remove the labware from the buckets or carriers.
3. If removing the rotor yoke, turn the tie-down T-bar to the left (counterclockwise) to loosen it. Lift the yoke straight up and off the drive shaft.

TUBES, BOTTLES, AND ACCESSORIES

The rotor uses labware listed in Tables 1 through 3. RCF limitations for some non-Beckman Coulter multiwell plates are shown in Table 4.



Temperature Limits

- Beckman Coulter plastic tubes and bottles have been centrifuge tested for use at temperatures between 2 and 25°C. For centrifugation at other temperatures, pretest tubes under anticipated run conditions.
- If plastic containers are frozen before use, make sure that they are thawed to at least 2°C prior to centrifugation.

Labware

Beckman Coulter tubes and bottles listed in Table 2 can be used in tube-and-bottle buckets. Refer to Table 3 for Beckman Coulter labware that can be centrifuged in multiwell-plate carriers.

RUN SPEEDS

The centrifugal force at a given radius in a rotor is a function of speed. Comparisons of forces between different rotors are made by comparing the rotors' relative centrifugal fields (rcf). When rotational speed is adjusted so that identical samples are subjected to the same rcf in two different rotors, the samples are subjected to the same force. The rcf at each speed is automatically calculated by the centrifuge software; if the rcf is entered, the centrifuge calculates the equivalent rpm (revolutions per minute). Run speeds must be reduced in the following circumstances:

Table 1. Adapters and Blood Bag Cups Available for the SX4750 Rotor

MODULAR DISK ADAPTERS (polypropylene)									
Color Code	Nom. Tube Vol. (mL)	Nom. Tube Dia. (mm)	Max. No. Tubes per Adapter	Max. No. Tubes in Rotor	r_{\max} at Adapter Bottom (mm)	RCF at Maximum Speed ($\times g$)	No. Disks per Adapter	Adapter Part No.	
								Set of Two	Set of Four
blue	3 5	10 12	37	148	184.7	4659	5	359469	359148
tan	3 & 5	13	30	120	184.7	4659	5	359478	359157
orange	7 & 10	14	24	96	184.7	4659	6	359470	359149
purple	12	16	19	76	184.7	4659	7	359471	359150
green (conical)	15	18	14	56	194.7	4911	6	359472	359151
green	15 & 20	18	14	56	184.7	4659	7	359473	359152
lt. green (conical)	30 & 50	30	4	16	191	4817	5	359475	359154
yellow	50	29	7	28	184.7	4659	6	359474	359153
dk. blue	50	35	4	16	184.7	4659	7	359476	359155
brown	100	44	2	8	184.7	4659	3	359477	359156
tube decanter	3 5	10 12	37	148	—	—	1	343108 ^a (each)	—
1.5-mL adapter plate	1.5 & 1.8	11	26	104	—	—	1	354511 ^a (each)	—

SOLID ADAPTER (polypropylene)								
Color Code	Nominal Tube Volume	Nominal Tube Size	Maximum Number of Tubes per Adapter	Maximum Number of Tubes in Rotor	r_{\max} at Adapter Bottom (mm)	RCF at Maximum Speed ($\times g$)	Adapter Part No.	
							Set of Two	Set of Four
grey	50-mL conical	29 \times 115 mm	7	28	195.6	4943	393266 ^b	393267 ^b

^a Tube retainers and adapter plates are sold individually.

Continued —

^b Do not autoclave this adapter. Use cold/chemical sterilization techniques only. Refer to STERILIZATION AND DISINFECTION.

^c Tube racks used with Aerosolve cannisters do not provide full tube support; some manufacturers' plastic and glass tubes cannot withstand the maximum forces generated by this rotor when used in these racks. Beckman Coulter highly recommends that you pretest other manufacturers' tubes (in the appropriate Aerosolve cannister labware) using water samples.

^d Cannisters and lids are made of polyphenylsulphone; O-rings are ethylene propylene. Cannister kit includes the pad (361269) that must be used beneath the cannister.

^e Corning polypropylene bottle.

^f Light purple adapter replaces the previous tan adapter. See note under SYMMETIC AND BALANCED LOADING for weight difference information.

Table 1. Adapters and Blood Bag Cups Available for the SX4750 Rotor (continued)

CELL CULTURE FLASK ADAPTERS (EPDM)								
Color Code	Flask Size (cm ²)	Number Flasks per Adapter		r_{\max} at Flask Bottom (mm)	RCF at Maximum Speed ($\times g$)	Part Number (qty two)		
orange	75	1		195.3	2080	369292		
green	25	2		177.5	2000	369295		
BLOOD BAG CUPS (polypropylene)								
Color Code	Cup Capacity	Size (mm)	Number Bags per Cup	r_{\max} at Cup Bottom (mm)	RCF at Maximum Speed ($\times g$)	Part Number (qty one)		
yellow	single bag double pack	90	2	196.2	4949	356856		
orange	triple pack quad pack	97	1	196.7	4961	356857		
AEROSOLVE CANNISTER RACKS (polypropylene)								
Color Code	Nom. Tube Vol. (mL)	Nom. Tube Dia. (mm)	Max. No. Tubes per Adapter	Max. No. Tubes in Rotor	r_{\max} at Adapter Base (mm)	RCF at Maximum Speed ($\times g$) ^c	Adapter Part Number	
							Set of Two	Set of Four
white	1.5	11	24	96	174	4389	354495 (each)	—
blue	3 & 5	12	24	96	174	4389	359482	359160
tan	5	12	24	96	180	4530	359489	358993
orange	10	14	18	72	175	4414	359483	359161
purple	12	16	12	48	177	4469	359484	359162
	3 & 5	12	6	24	178	4490		
white (vials)	15	14	10	40	174	4389	344517 (each)	—

^a Tube retainers and adapter plates are sold individually.

Continued —

^b Do not autoclave this adapter. Use cold/chemical sterilization techniques only. Refer to STERILIZATION AND DISINFECTION.

^c Tube racks used with Aerosolve cannisters do not provide full tube support; some manufacturers' plastic and glass tubes cannot withstand the maximum forces generated by this rotor when used in these racks. Beckman Coulter highly recommends that you pretest other manufacturers' tubes (in the appropriate Aerosolve cannister labware) using water samples.

^d Cannisters and lids are made of polyphenylsulphone; O-rings are ethylene propylene. Cannister kit includes the pad (361269) that must be used beneath the cannister.

^e Corning polypropylene bottle.

^f Light purple adapter replaces the previous tan adapter. See note under SYMMETIC AND BALANCED LOADING for weight difference information.

Table 1. Adapters and Blood Bag Cups Available for the SX4750 Rotor (continued)

AEROSOLVE CANNISTER RACKS (polypropylene)								
Color Code	Nom. Tube Vol. (mL)	Nom. Tube Dia. (mm)	Max. No. Tubes per Adapter	Max. No. Tubes in Rotor	r_{\max} at Adapter Base (mm)	RCF at Maximum Speed ($\times g$) ^c	Adapter Part Number	
							Set of Two	Set of Four
green	15 & 20 3 & 5	18 12	12 6	48 24	174 176	4389 4439	359485	359163
lt. green	15 (conical) 3 & 5 (round bottom)	17	6	24	181	4565	359487	358991
		12	6	24	180	4539		
lime green	50 (conical) 3 & 5 (round bottom)	30	4	16	181	2850	359488	358992
		12	4	16	180	4539		
yellow	50 3 & 5	29 12	4 4	16 16	177 178	4464 4490	359486	359164
orange	230	62	1	4	180	4534	—	356985
Cannister Kit ^d	500	—	—	—	183	4616	359481	359232

BOTTLE ADAPTERS (polypropylene)						
Color Code	Nominal Bottle Volume (mL)	Nominal Bottle Diameter (mm)	Maximum Number Bottles in Rotor	r_{\max} at Bottle Bottom (mm)	RCF at Maximum Speed ($\times g$)	Adapter Part Number (qty one)
orange (conical)	230	62	4	195.1	4921	356983 (use with 349946)
yellow	250	62	4	195.1	4921	349946
warm red (conical)	250 ^e	62	4	203.2	5125	349849
light purple ^f	500	70	4	200.2	6050	349945
blue	750	96	4	195.2	4921	349846

^a Tube retainers and adapter plates are sold individually.

^b Do not autoclave this adapter. Use cold/chemical sterilization techniques only. Refer to STERILIZATION AND DISINFECTION.

^c Tube racks used with Aerosolve cannisters do not provide full tube support; some manufacturers' plastic and glass tubes cannot withstand the maximum forces generated by this rotor when used in these racks. Beckman Coulter highly recommends that you pretest other manufacturers' tubes (in the appropriate Aerosolve cannister labware) using water samples.

^d Cannisters and lids are made of polyphenylsulphone; O-rings are ethylene propylene. Cannister kit includes the pad (361269) that must be used beneath the cannister.

^e Corning polypropylene bottle.

^f Light purple adapter replaces the previous tan adapter. See note under SYMMETIC AND BALANCED LOADING for weight difference information.

Table 2. Beckman Coulter Tubes and Bottles for the SX4750 Rotor

Dimensions	Volume (mL) ^a	Description	Part Number	Adapter	
				Set of Two	Set of Four
OPEN-TOP TUBES					
16 × 76 mm	10	polyallomer	355640	349471 359484 ^b	359150 359162 ^b
16 × 76 mm	10	polycarbonate	355630	359471 359484 ^b	359150 359162 ^b
16 × 76 mm	10	stainless steel	301108	359471 359484 ^b	359150 359162 ^b
18 × 98 mm	15	polycarbonate	342080	359473	359152
18 × 98 mm	15	polyethylene	342081	359473	359152
18 × 98 mm	15	polypropylene	342082	359473	359152
29 × 104 mm	50	polycarbonate, graduated	363075 (pkg/8)	359474 359486 ^b	359153 359164 ^b
29 × 103 mm	50	polypropylene	357007	359474 359486 ^b	359153 359164 ^b
29 × 103 mm	50	polycarbonate	363647	359474 359486 ^b	359153 359164 ^b
TUBES WITH SNAP-ON CAPS					
11 × 38 mm	1.5	polyallomer	357448	359469 354511 ^c 354495 ^b	359148
11 × 38 mm	1.5	polypropylene	356090	359469 354511 ^c 354495 ^b	359148
11 × 38 mm	1.5	blue polypropylene	356091	359469 354511 ^c 354495 ^b	359148
11 × 38 mm	1.5	green polypropylene	356092	359469 354511 ^c 354495 ^b	359148
11 × 38 mm	1.5	yellow polypropylene	356093	359469 354511 ^c 354495 ^b	359148

^a Fill tubes at least half full. Speed reduction may be required for fill volumes below 75 percent.

^b Adapter used in Aerosolve cannister (part number 359232).

^c Tube retainers and adapter plates are sold individually.

^d These tubes cannot be run with bucket covers in place.

^e Do not load the 750-mL bottle directly into the bucket; always use the adapter.

^f Replacement bottle cap part number is 356263 (set of 6).

Continued —

Table 2. Beckman Coulter Tubes and Bottles for the SX4750 Rotor (continued)

Dimensions	Volume (mL) ^a	Description	Part Number	Adapter	
				Set of Two	Set of Four
TUBES WITH SNAP-ON CAPS (continued)					
11 × 38 mm	1.5	orange polypropylene	356094	359469 354511 ^c 354495 ^b	359148
11 × 38 mm	1.5	polypropylene (cap separate)	343169	359469 354511 ^c 354495 ^b	359148
11 × 39 mm	1.8	white polyethylene	340196	359469 354511 ^c 354495 ^b	359148
29 × 103 mm	50	polypropylene	357005	359474 359486 ^b	359153 359164 ^b
29 × 103 mm	50	polycarbonate	363664	359474 359486 ^b	359153 359164 ^b
CONICAL TUBES					
62 × 141 mm	230	polycarbonate (with cap)	356987	349946	356983 356985 ^b
62 × 141 mm	230	polypropylene (with cap)	356989	349946	356983 356985 ^b
BIOVIALS					
14 × 55 mm	4	polypropylene	566353	359470 344517 ^b (each)	359149
BOTTLES					
29 × 104 mm	50	polycarbonate (with cap assembly)	361693	359474 359486 ^b	359153 359164 ^b
29 × 104 mm	50	polycarbonate (with screw cap)	357002	359474 359486 ^b	359153 359164 ^b

^a Fill tubes at least half full. Speed reduction may be required for fill volumes below 75 percent.

^b Adapter used in Aerosolve cannister (part number 359232).

^c Tube retainers and adapter plates are sold individually.

^d These tubes cannot be run with bucket covers in place.

^e Do not load the 750-mL bottle directly into the bucket; always use the adapter.

^f Replacement bottle cap part number is 356263 (set of 6).

Continued —

Table 2. Beckman Coulter Tubes and Bottles for the SX4750 Rotor (continued)

Dimensions	Volume (mL) ^a	Description	Part Number	Adapter	
				Set of Two	Set of Four
BOTTLES (continued)					
29 × 104 mm	50	polyallomer (with cap assembly)	357001 or 361694	359474 359486 ^b	359153 359164 ^b
29 × 104 mm	50	polyallomer (with screw cap)	357003	359474 359486 ^b	359153 359164 ^b
28.5 × 107 mm	50	Teflon with high-speed screw cap	363076 ^d	359474 359486 ^b	359153 359164 ^b
62 × 141 mm	230	conical, wide-mouth polycarbonate	356987 ^d	356983 (use w/ 349946)	—
62 × 141 mm	230	conical, wide-mouth polypropylene	356989 ^d	356983 (use w/ 349946)	—
62 × 136 mm	250	polycarbonate (with screw cap, round bottom)	355673	349946	—
62 × 122 mm	250	wide-mouth polycarbonate (with cap)	356013	349946	—
62 × 122 mm	250	wide-mouth polypropylene (with cap)	356011	349946	—
62 × 122 mm	250	wide-mouth polycarbonate	358275	349946	—
62 × 120 mm	250	wide-mouth polypropylene	358326	349946	—
69 × 160 mm	500	polypropylene (with cap assembly)	355607 ^d	349945	—
69 × 159 mm	500	polypropylene (with cap)	355665 ^d	349945	—
69 × 159 mm	500	polypropylene	355650 ^d	349945	—
96 × 130 mm	750	polycarbonate (with screw cap ^f)	358299 ^e	349846	—
96 × 130 mm	750	polypropylene (with screw cap ^f)	356855 ^e	349846	—

^a Fill tubes at least half full. Speed reduction may be required for fill volumes below 75 percent.

^b Adapter used in Aerosolve cannister (part number 359232).

^c Tube retainers and adapter plates are sold individually.

^d These tubes cannot be run with bucket covers in place.

^e Do not load the 750-mL bottle directly into the bucket; always use the adapter.

^f Replacement bottle cap part number is 356263 (set of 6).

Table 3. Beckman Coulter Labware for Use with Multiwell-Plate Carriers

Description	Volume	Part Number	Available Accessory	
			Description	Part Number
Multiwell plate, 96-well, nonsterile	300 μ L/well	609844* (pkg/100)	Cap strip, nonsterile*	267002 (pkg/10)
			Cap strip, sterile*	267005 (pkg/10)
			Aluminum foil lid†	538619 (pkg/100)
Deep-well polystyrene plate, 96-well, nonsterile	1 mL/well	267001 (pkg/24)	Cap strip, nonsterile*	267002 (pkg/10)
			Cap strip, sterile*	267005 (pkg/10)
			Aluminum foil lid†	538619 (pkg/100)
Deep-well polystyrene plate, 96-well, sterile	1 mL/well	267004 (pkg/24)	Cap strip, nonsterile*	267002 (pkg/10)
			Cap strip, sterile*	267005 (pkg/10)
			Aluminum foil lid†	538619 (pkg/100)
Deep-well polypropylene plate, 96-well, nonsterile	1 mL/well	267006 (pkg/24)	Cap strip, nonsterile*	267002 (pkg/10)
			Cap strip, sterile*	267005 (pkg/10)
			Aluminum foil lid†	538619 (pkg/100)
Deep-well polypropylene plate, 96-well, sterile	1 mL/well	267007 (pkg/24)	Cap strip, nonsterile*	267002 (pkg/10)
			Cap strip, sterile*	267005 (pkg/10)
			Aluminum foil lid†	538619 (pkg/100)
Square-well polypropylene plate	2 mL/well	140504 (pkg/24)	Aluminum foil lid†	538619 (pkg/100)

* Caps are optional; however, if stacking two or three multiwell plates, use cap strips between plates for speeds greater than 2700 rpm.

† Requires soft rubber roller (4-in.), part number 538618, for installation.

- If the weight of the load *in a tube-and-bottle bucket* exceeds 1000 grams, or if the solution density is more than 1.2 g/mL, reduce the maximum allowable run speed according to the following equation:

$$\text{reduced maximum speed} = (4750 \text{ rpm}) \sqrt{\frac{1000 \text{ grams}}{\text{heaviest load in grams}}} \quad (1)$$

Table 4. Commercially Available Labware for Use with Multiwell-Plate Carriers

Description	Volume	Part Number	Required Accessory	
			Description	Part Number
BD Falcon* 96-well flat-bottom assay plate, clear polystyrene, standard surface, nonsterile	300 μ L/well	BD Falcon 353915 [†] (5/bag, 50/case)	—	—
BD Falcon 96-well flat-bottom ELISA plate, clear polystyrene, enhanced surface, non sterile	300 μ L/well	BD Falcon 353279 [†] (25/sleeve, 100/case)	—	—
BD Falcon 96-well flat-bottom assay plate, clear polystyrene, standard surface, nonsterile	300 μ L/well	BD Falcon 353228 [†] (10/bag, 60/case)	—	—

*BD Falcon is a trademark of Becton, Dickinson and Company.

[†]These plates can be run at 4450 rpm (4063 \times g), up to four plates per carrier, without lids or cap strips.

- If the weight of the load in a *multiwell-plate carrier* exceeds 360 grams, reduce the maximum allowable run speed according to the following equation:

$$\text{reduced maximum speed} = (4450 \text{ rpm}) \sqrt{\frac{360 \text{ grams}}{\text{heaviest load in grams}}} \quad (2)$$

Do not select rotational speeds in excess of 4750 rpm for tube-and-bottle buckets or 4450 rpm for multiwell-plate carriers in an Allegra X-15R, or 3750 rpm for either buckets or carriers in an Allegra X-12 series centrifuge. (Up to three Beckman Coulter plates can be run per carrier at maximum multiwell-plate speeds. If running four Beckman Coulter plates, reduce run speed to 2700 rpm. Observe manufacturer's run speed and stacking limitations if using other manufacturers' multiwell plates.) If using multiwell plates for runs exceeding 2 hours in a warm and/or humid environment, speed reduction may be required to maintain low sample temperatures.

CARE AND MAINTENANCE

MAINTENANCE

Do not use sharp tools on the rotor that could cause scratches in the rotor surface. Corrosion begins in scratches and may open fissures in the rotor with continued use.

- Periodically (at least monthly) inspect the rotor yoke, buckets, and/or multiwell-plate carriers, especially inside cavities, for rough spots or pitting, white powder deposits—frequently aluminum oxide—or heavy discoloration. If any of these signs are evident, do not run the rotor. Contact your Beckman Coulter representative for information about the Field Rotor Inspection Program and the rotor repair center.
- Approximately every 400 runs, and after cleaning and/or autoclaving, wipe the rotor pins and pin sockets (see Figure 5) with a paper towel, then coat the sockets with Paint On Graphite Lubricant (977212). Allow the lubricant to dry for at least 5 minutes before installing the rotor in a centrifuge.

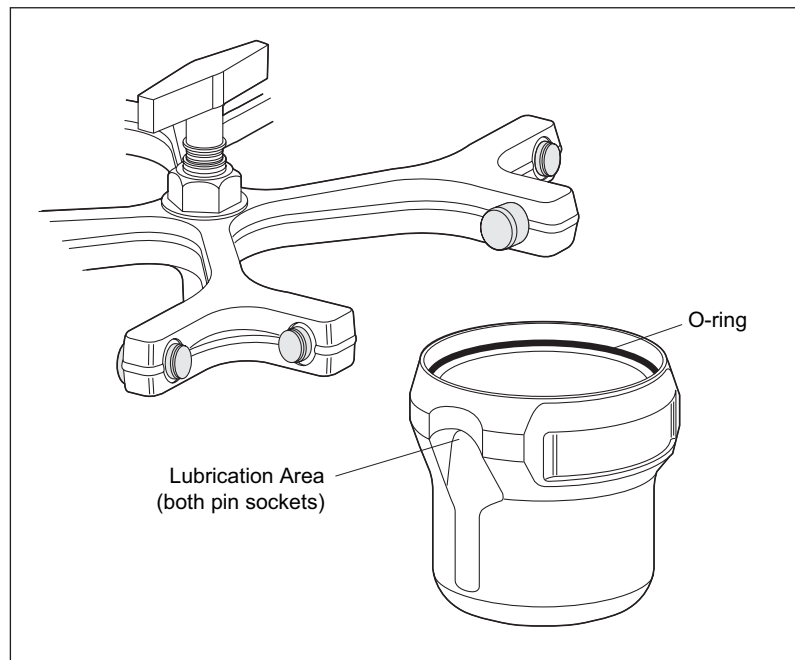

Figure 5. Lubricating Pivot Pin/Bucket Contact Areas

- Refer to publication TJ6-TB-011 (supplied with the cannister kit) for information on Aerosolve cannister maintenance.
- Refer to publication GX-TB-007 for information on 25-cm² cell culture flask adapter maintenance or GX-TB-006 for 75-cm² flask adapters.

Store the rotor in a dry environment (not in the centrifuge). Refer to *Chemical Resistances* (publication IN-175) for the chemical compatibilities of rotor and accessory materials. Your Beckman Coulter representative provides contact with the Field Rotor Inspection Program and the rotor repair center.

CLEANING

Wash rotor components immediately if salts or other corrosive materials are used or if spillage has occurred. Do not allow corrosive materials to dry on the rotor.

Under normal use, wash the rotor frequently to prevent buildup of residues.

NOTE

Do not wash the rotor components in a dishwasher. Do not soak the rotor in detergent solution for long periods, such as overnight.



1. Wash the rotor yoke, buckets, bucket covers, and multiwell-plate carriers and covers in a mild detergent, such as Beckman Solution 555™ (339555), that won't damage the rotor. The Rotor Cleaning Kit (339558) contains two plastic-coated brushes and two quarts of Solution 555 for use with rotors and accessories. Dilute the detergent 10 to 1 with water.
2. Thoroughly rinse the cleaned rotor components with distilled water.
3. Air-dry the rotor components upside down. *Do not use acetone to dry the rotor.*

Before reinstalling the rotor yoke, lightly lubricate the drive hole with Spinkote (306812) to prevent the rotor from sticking.

Modular Disk Adapters

1. To disassemble adapters for washing, first pull the bail out of the groove in the disks, then remove the disks and unsnap the bail from the rubber bottom.
2. Use a mild detergent such as Solution 555 (339555), diluted 10 to 1 with water, and a soft brush to scrub the adapters.
3. Rinse and dry, then reassemble.

Cell Culture Flask Adapters

Refer to publication GX-TB-007 (25-cm² flask adapters) or GX-TB-006 (75-cm² flask adapters) for cell culture flask adapter cleaning instructions.

DECONTAMINATION



If aluminum rotor components become contaminated with radioactive material, decontaminate them using a solution that will not damage the anodized surfaces. Beckman Coulter has tested a number of solutions and found two that do not harm anodized aluminum: RadCon Surface Spray or IsoClean Solution (for soaking),⁶ and Radiacwash.⁷

While Beckman Coulter has tested these materials and found that they do not damage components, no guarantee of decontamination is expressed or implied. Follow appropriate decontamination procedures as directed by your laboratory safety officer.



If the rotor or other components are contaminated with toxic or pathogenic materials, follow appropriate decontamination procedures as directed by your laboratory safety officer.

⁶ In U.S.A., contact Nuclear Associates (New York); in Eastern Europe and Commonwealth States, contact Victoreen GmbH (Munich); in South Pacific, contact Gammasonics Pty, Ltd. (Australia); in Japan, contact Toyo Medic Co. Ltd. (Tokyo).

⁷ In U.S.A., contact Biodex Medical Systems (Shirley, NY); internationally, contact the U.S. office to find the dealer nearest you.

STERILIZATION AND DISINFECTION

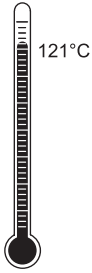

- The rotor yoke, buckets, adapters, and multiwell-plate carriers can be autoclaved at 121°C for up to an hour. Blood bag cups, bucket and carrier covers, and Aerosolve cannisters can be autoclaved at that temperature for about 15 minutes. (Do not autoclave Aerosolve cannisters purchased prior to April 1993, or any components made of Noryl.) Remove the covers from the buckets and place the rotor yoke, buckets, covers, and/or multiwell-plate carriers in the autoclave upside down. Before autoclaving, remove the air-vent filter from each cover by gently pushing it out from underneath the cover with a pencil or other non-metal tool that will not scratch the cover material. After autoclaving, insert a new air-vent filter (368148) into each cover.
- Ethanol (70%)⁸ or hydrogen peroxide (6%) may be used on all rotor components, including those made of plastic. Bleach (sodium hypochlorite) may be used, but may cause discoloration of anodized surfaces. Use the minimum immersion time for each solution, per laboratory standards.

While Beckman Coulter has tested these methods and found that they do not damage the rotor or components, no guarantee of sterility or disinfection is expressed or implied. When sterilization or disinfection is a concern, consult your laboratory safety officer regarding proper methods to use.

Refer to publication IN-192 (included with each box of tubes) for tube and bottle sterilization and disinfection procedures.

TUBE BREAKAGE



CAUTION

To reduce the potential for corrosion, clean buckets or carriers thoroughly immediately following a tube or well plate breakage.

If a glass tube breaks, remove the glass very carefully from the adapter and bucket. Imbedded glass particles that remain in the bucket or adapters can cause tube failure during subsequent runs.

⁸ Flammability hazard. Do not use in or near operating centrifuges.

Aerosolve Cannisters



WARNING

When working with potentially hazardous materials, open cannisters in an appropriate hood or biological safety cabinet in case of tube breakage.

If a glass tube breaks in an Aerosolve cannister tube rack, discard and replace the O-ring and rubber tube cushion in the base of the rack. Imbedded glass particles that remain in the bucket or adapters can break tubes during subsequent runs.

SST or Corvac Tubes

If an SST or Corvac tube breaks, the tube's silicone gel barrier material becomes laced with glass fragments and the tube contents contaminate the entire tube adapter and bucket (or tube rack and cannister).

If one of these tubes breaks in an adapter *in a bucket*, use the following procedure.

1. Fill the bucket with water.
2. Autoclave the entire bucket and contents at 121°C for 20 minutes.
3. Decant any remaining water and dislodge the tube adapter (do not remove it) over a waste container.
4. Working under a hood and using plastic gloves, immerse the bucket and tube adapter (intact) in a beaker or similar vessel containing ethyl acetate.⁹
5. Scrub the adapter with a brush and decant the ethyl acetate mixture into a waste bottle for proper disposal.
6. Rinse with water and air-dry the bucket and tube adapter.

If one of these tubes breaks *in an Aerosolve cannister*, use the following procedure.

⁹ Flammability hazard. Do not use in or near operating centrifuges.

1. Working in a biologic safety cabinet and wearing plastic gloves, open the cannister and immerse the cannister, lid, and contents (intact) in a beaker or similar vessel containing 6% sodium hypochlorite (undiluted bleach).
2. Leave the cannister to soak overnight.
3. Carefully dislodge the tube rack and scrub it with a brush.
4. Decant the bleach into a waste bottle for proper disposal.
5. Rinse with water and air-dry the cannister and tube rack.

STORAGE

When it is not in use, store the rotor in a dry environment (not in the centrifuge).

RETURNING A ROTOR

Before returning a rotor or accessory for any reason, prior permission (a Returned Goods Authorization form) must be obtained from Beckman Coulter, Inc. This RGA form, which may be obtained from your local Beckman Coulter sales office, should contain the following information:

- rotor serial number,
- history of use (approximate frequency of use),
- reason for the return,
- original purchase order number, billing number, and shipping number, if possible,
- name and phone number of the person to be notified upon receipt of the rotor or accessory at the factory, and
- name and phone number of the person to be notified about repair costs, etc.

To protect our personnel, it is the customer's responsibility to ensure that the parts are free from pathogens and/or radioactivity. Sterilization and decontamination must be done before returning the parts. Smaller items (such as tubes, bottles, etc.) should be enclosed in a sealed plastic bag.

*All parts must be accompanied by a note, plainly visible on the outside of the box or bag, stating that they are safe to handle and that they are not contaminated with pathogens or radioactivity. **Failure to attach this notification will result in return or disposal of the items without review of the reported problem.***

Use the address label printed on the RGA form when mailing the rotor and/or accessories to:

Beckman Coulter, Inc.
1050 Page Mill Road
Palo Alto, CA 94304

Attention: Returned Goods

Customers located outside the United States should contact their local Beckman Coulter office.

SUPPLY LIST

NOTE

Publications referenced in this manual can be obtained by calling Beckman Coulter at 1-800-742-2345 in the United States, or by contacting your local Beckman Coulter office.

Contact Beckman Coulter Sales (1-800-742-2345 in the United States; worldwide offices are listed on the back cover of this manual) for detailed information on ordering parts and supplies. For your convenience, a partial list is given below.

REPLACEMENT ROTOR PARTS

SX4750 rotor assembly (tube-and-bottle buckets)	369702
Tube-and-bottle bucket (set of 2)	392804
Tube-and-bottle bucket cover (set of 2)	392805
Tube-and-bottle bucket O-ring (pkg/8)	961648
Tube-and-bottle bucket cover latch assembly	360587
SX4750 μ rotor assembly (multiwell-plate carriers)	393042
Multiwell-plate carrier (set of 2)	392806
Multiwell-plate carrier cover (set of 2)	393071
Multiwell-plate carrier cover gasket (set of 4)	392812
Multiwell-plate carriage (set of 2)	392873
Multiwell-plate support pad (set of 4)	392872
Bucket/carrier cover air-vent filter (set of 60)	368148
Tie-down T-bar	369716

SUPPLIES

Adapters	see Table 1
Tubes and bottles	see Table 2
Multiwell-plate labware	see Table 3
Soft rubber roller (for aluminum foil lids)	538618
Tube decanter (for use with blue adapter)	343108
includes:	
gasket for 10-mm dia tubes (silicone)	343106
gasket for 12-mm dia tubes (silicone)	343107
Adapter plate, 1.5-mL (for use with blue adapter)	354511

Aerosolve cannister kit (set of 4) (each kit includes 1 cannister, 1 lid, 1 O-ring, silicone vacuum grease, and 1 pad)	359232
Aerosolve cannister O-ring (ethylene propylene)	345366
Aerosolve pad (placed beneath cannister in bucket) (polyethylene)	361269
Tube racks for Aerosolve cannisters	see Table 1
Neoprene tube cushions	
for blue rack (pkg of 24)	344117
for orange rack (pkg of 18)	344118
for purple rack (pkg of 18; 12 large, 6 small)	344119
for dark green rack (pkg of 18; 12 large, 6 small)	344120
for yellow rack (pkg of 8; 4 large, 4 small)	344121
Blood bag cup, 90-mm, yellow (polypropylene)	356856
Blood bag cup, 97-mm, orange (polypropylene)	356857
Balancing pads (six pads, 3 grams each, red)	358365
Cell culture flask adapter, 75-cm ² (pkg of 2)	369292
Cell culture flask adapter, 25-cm ² (pkg of 2)	369295
Rotor Cleaning Kit	339558
Solution 555 (1 qt)	339555
Silicone vacuum grease (1 oz)	335148
Spinkote lubricant (2 oz)	306812
Paint On Graphite Lubricant	977212

SX4750 ROTOR WARRANTY

Subject to the conditions specified below and the warranty clause of the Beckman Coulter, Inc., terms and conditions in effect at the time of sale, Beckman Coulter agrees to correct either by repair or, at its election, by replacement, any defects of material or workmanship which develop within one (1) year after delivery of a benchtop centrifuge rotor to the original buyer by Beckman Coulter or by an authorized representative, provided that investigation and factory inspection by Beckman Coulter discloses that such defect developed under normal and proper use. Should a Beckman Coulter centrifuge be damaged due to a failure of a rotor covered by this warranty, Beckman Coulter will supply free of charge all centrifuge parts required for repair.

CONDITIONS

1. Except as otherwise specifically provided herein, this warranty covers the rotor only and Beckman Coulter shall not be liable for damage to accessories or ancillary supplies including but not limited to (i) tubes, (ii) tube caps, (iii) tube adapters, or (iv) tube contents.

2. This warranty is void if the rotor has been subjected to customer misuse such as operation or maintenance contrary to the instructions in the Beckman Coulter rotor or centrifuge manual.
3. This warranty is void if the rotor is operated with a rotor drive unit or in a centrifuge unmatched to the rotor characteristics or operated in a Beckman Coulter centrifuge that has been improperly disassembled, repaired, or modified.
4. Thermoplastic rotors or components used in some benchtop centrifuges are warranted for one (1) year from date of purchase.

DISCLAIMER

IT IS EXPRESSLY AGREED THAT THE ABOVE WARRANTY SHALL BE IN LIEU OF ALL WARRANTIES OF FITNESS AND OF THE WARRANTY OF MERCHANTABILITY AND THAT BECKMAN COULTER, INC. SHALL HAVE NO LIABILITY FOR SPECIAL OR CONSEQUENTIAL DAMAGES OF ANY KIND WHATSOEVER ARISING OUT OF THE MANUFACTURE, USE, SALE, HANDLING, REPAIR, MAINTENANCE, OR REPLACEMENT OF THE PRODUCT.

Beckman Coulter Worldwide Biomedical Research Division Offices

AUSTRALIA

Beckman Coulter Australia Pty Ltd
Unit D, 24 College St.
Gladesville, NSW 2111
Australia
Telephone: (61) 2 9844-6000
or toll free: 1 800 060 880
Fax: (61) 2 9844-6096
email: lifescienceaustralia@beckman.com

CANADA

Beckman Coulter (Canada) Inc.
6755 Mississauga Road, Suite 600
Mississauga, Ontario
Canada L5N 7Y2
Telephone: (1) 905 819-1234
Fax: (1) 905 819-1485

CHINA

Beckman Coulter Inc.
Beijing Representative Office
Unit 2005A, 2006-2009, East Ocean Center
Jian Guomenwai Avenue
Beijing 100004
China
Telephone: (86) 10 6515 6028
Fax: (86) 10 6515 6025, 6515 6026

CZECH REPUBLIC

Beckman Coulter Prague
Radiova 1
102 27 Prague 10
Czech Republic
Telephone: (420) 267 00 85 13
Fax: (420) 267 00 83 23

EASTERN EUROPE/ MIDDLE EAST/NORTH AFRICA

Beckman Coulter International S.A.
22, Rue Juste-Olivier
Case Postale 301-303
CH-1260 Nyon, Switzerland
Telephone: (41) 22 365 3707
Fax: (41) 22 365 0700

FRANCE

Beckman Coulter France S.A.
Paris Nord II, 33/66 rue des Vanesses
B.P. 50359
Villepinte, France
95942 ROISSY CDG Cedex
Telephone: (33) 1 49 90 90 00
Fax: (33) 1 49 90 90 10
e-mail: bioresearch.france@beckman.com

GERMANY

Beckman Coulter GmbH
Europark Fichtenhain B-13
47807 Krefeld
Germany
Telephone: (49) 21 51 33 35
Fax: (49) 21 51 33 33
e-mail: bioresearch.de@beckman.com

HONG KONG

Beckman Coulter Hong Kong Ltd.
12th Floor, Oxford House
979 King's Road
Taikoo Place, Hong Kong
Telephone: (852) 2814 7431
Fax: (852) 2873 4511

INDIA

Beckman Coulter India Pvt. Ltd.
Solitaire Corporate Park
3rd Floor - Bldg. 11
Andheri Ghatkopar Link Road
Chakala, Andheri West
Mumbai India 400 098
Telephone: (91) 22 3080 5101

ITALY

Beckman Coulter S.p.a.
Centro Direzionale Lombardo
Palazzo F/1, Via Roma 108
20060 Cassina de' Pecchi
Milano, Italy
Telephone: (39) 02 953921
Fax: (39) 02 95392264

JAPAN

Beckman Coulter K.K.
TOC Ariake West Tower
2-5-7, Ariake, Koto-ku
Tokyo 135-0063 Japan
Telephone: (81) 3 5530 8500
Fax: (81) 3 5404 8436

MEXICO

Beckman Coulter de Mexico S.A. de C.V.
Avenida Popocatépetl #396
Colonia Gral. Pedro Maria Anaya
Codigo Postal 03340
Mexico, D.F. Mexico
Telephone: (001) 52-55-9183-2800

NETHERLANDS

Beckman Coulter Nederland B.V.
Nijverheidsweg 21
3641 RP-Mijdrecht
Postbus 47
3640 AA Mijdrecht
The Netherlands
Telephone: (31) 297-230630
Fax: (31) 297-288082

SINGAPORE

Beckman Coulter Singapore Pte. Ltd.
116 Changi Road
Unit #03-01/02
Singapore 419718
Telephone: (65) 6339 3633
Fax: (65) 6336 6303

SOUTH AFRICA/SUB-SAHARAN AFRICA

Beckman Coulter
Stand 1A Primegro Park
Tonetti Street
1685 Halfway House
Johannesburg
Republic of South Africa
Telephone: (27) 11-805-2014/5
Fax: (27) 11-805-4120
e-mail: beckman@intekom.co.za

SPAIN

Beckman Coulter España S.A.
C/ Caleruega, 81
28033 Madrid, Spain
Telephone: (34) 91 3836080
Fax: (34) 91 3836096
email: bioresearch.espana@beckman.com

SWEDEN

Beckman Coulter AB
Archimedesvaegen 7
Box 111 56
SE-168 11 Bromma
Sweden
Telephone: (46) 8 564 85 900
Telefax: (46) 8 564 85 901

SWITZERLAND

Beckman Coulter International S.A.
22, Rue Juste-Olivier
Case Postale 301-303
CH-1260 Nyon
Switzerland
Telephone: (41) 0800 850 810
Fax: (41) 0848 850 810

TAIWAN

Beckman Coulter Taiwan Inc.
Taiwan Branch
8th Floor
216 Tun Hwa South Road, Section 2
Taipei 106, Taiwan
Republic of China
Telephone: (886) 2 2378 3456
Fax: (886) 2 2377 0408

TURKEY

Beckman Coulter Ltd.
E-5 Yanyol Faith Cad.
81410 Soganklik Kartal
Istanbul
Turkey
Telephone: (90) 216 309 1900
Fax: (90) 216 309 0090

UNITED KINGDOM

Beckman Coulter United Kingdom Ltd
Oakley Court
Kingsmead Business Park
London Road
High Wycombe
Buckinghamshire HP11 1JU
England, U.K.
Telephone: (44) 01494 441181
Fax: (44) 01494 447558
e-mail: beckman_uk@beckman.com

*Additional addresses are available at
www.beckmancoulter.com.*



Beckman Coulter, Inc. • 4300 N. Harbor Boulevard, Box 3100 • Fullerton, California 92834-3100
Sales and Service: 1-800-742-2345 • Internet: www.beckmancoulter.com • Telex: 678413 • Fax: 1-800-643-4366

