

**Scotsman®**

Installation and  
User's Manual for  
Outdoor Model Residential Ice Machine  
Models SCCG50M-1SS and SCCP50M-1SS



Brilliance™

# SCCG50 & SCCP50 - Outdoor Model Installation and User's Manual

## Introduction:

This ice machine is the result of Scotsman's decades of experience as an industry leader in the design and manufacture of both commercial and residential ice machines.

This manual includes the information needed to install, start up and maintain the ice machine. Note any Caution or Warning indicators, as they provide notice of potential hazards. Keep this manual for future reference.

## Table of Contents

Specifications . . . . .	Page 2
Air flow . . . . .	Page 3
Cabinet Drawing . . . . .	Page 4
Water Quality . . . . .	Page 5
Door swing change . . . . .	Page 6
Installation: Water & Drain . . . . .	Page 7
Gravity Drain . . . . .	Page 8
Electrical . . . . .	Page 9
Use . . . . .	Page 10
Maintenance . . . . .	Page 11
How to clean the condenser and winterize. . . . .	Page 12
How to remove scale from the ice making system. . . . .	Page 13
What to do before calling for service . . . . .	Page 14

### Outdoor Use Notice:

Keep from freezing. Severe damage will occur to the unit if left in or operated in temperatures beyond the limits listed in this manual. That damage is NOT covered by warranty.

Keep dry. Do not locate in low lying areas where puddles will accumulate.

Provide Shade: Heat gain from the sun will reduce the unit's ability to make and store ice, and ultraviolet radiation from the sun can potentially damage the unit's plastic components.

Water Supply: Avoid a long run of hose or tubing exposed to the sun. Plastic water supply tubing should be rated for potable water and include UV protection. Copper tubing is recommended.

Back Flow Prevention: The unit includes back flow prevention, no additional check valve is required.

Drainage: Do Not drain into swimming pool or onto grounds.

Operation: It is normal for the ice level in the storage bin to be low when unit is used in temperatures below 65 degrees F.

**Specifications**

This ice machine is designed to be used indoors, in a controlled environment or outdoors within certain limits. It can be used in a wide variety of environmental conditions, but there are limits. Use outside of the listed limitations is misuse and will void the warranty.

**Air temperature limits:**

The ice machine will operate adequately within the limits, but functions best in temperatures between 70 and 80 degrees F.

- Minimum – 50 degrees F. (10°C)
- Maximum – 100 degrees F. (38°C)

**Water temperature limits:**

- Minimum – 40 degrees F. (4.5°C)
- Maximum – 100 degrees F. (38°C)

**Water pressure limits:**

- Minimum – 20 psi (1.4 bar)
- Maximum – 80 psi (5.5 bar)

Because the ice machine is making a food product, the water supply to the ice machine must be potable, or fit for human consumption.

**Electrical voltage limits:**

- Minimum - 104 volts
- Maximum – 126 volts

**Models**

There are two models, both air cooled:

- SCCP50M-1SS – Pump model, stainless cabinet and door
- SCCG50M-1SS – Gravity drain model, stainless cabinet and door

**Dimensions**

Width	Depth, handle adds 1 5/8"	Height
14 7/8"	22 3/4"	33 3/8" to 34 3/8"

**Options:**

**Drain Conversion:**

A gravity drain model can be converted to a drain pump model by installing a drain pump kit. The drain pump kit consists of a drain pump, wiring harness and associated tubing. The part number is A39462-021.

**Warranty Information**

Warranty information is supplied separately from this manual. Refer to it for coverage. In general, the warranty covers defects in materials or workmanship and does not cover corrections of installation errors or maintenance.

# SCCG50 & SCCP50 - Outdoor Model Installation and User's Manual

## Air flow

The machine takes in room temperature air at the lower right front and forces warm air out the lower left front. Restricting the airflow or operating the machine in a hot or cold environment will adversely affect the ability of the ice machine to make ice.

When the door is opened, the control panel, ice making area and ice storage bin are visible. The scoop is located in a holder along the right side wall.



Scotsman Ice Systems are designed and manufactured with the highest regard for safety and performance. They meet or exceed the standards of agencies like U.L.

Scotsman assumes no liability or responsibility of any kind for products manufactured by Scotsman that have been altered in any way, including the use of any parts and/or other components not specifically approved by Scotsman.

Scotsman reserves the right to make design changes and/or improvements at any time.

Specifications and designs are subject to change without notice.

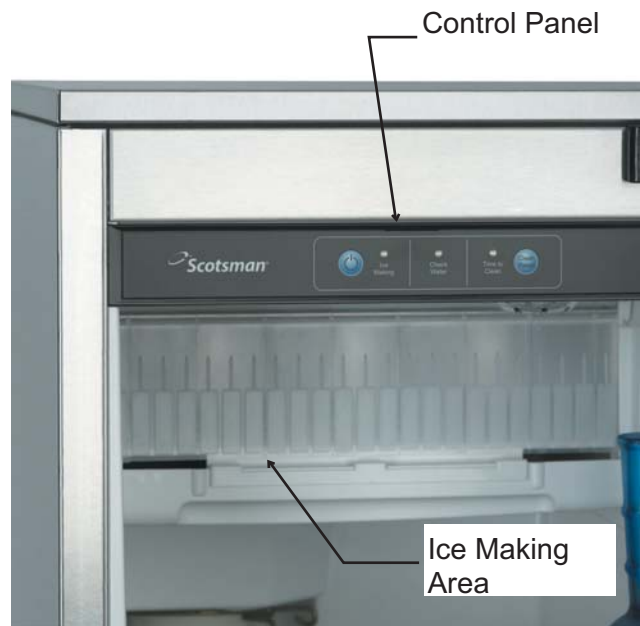

## Cabinet Drawing

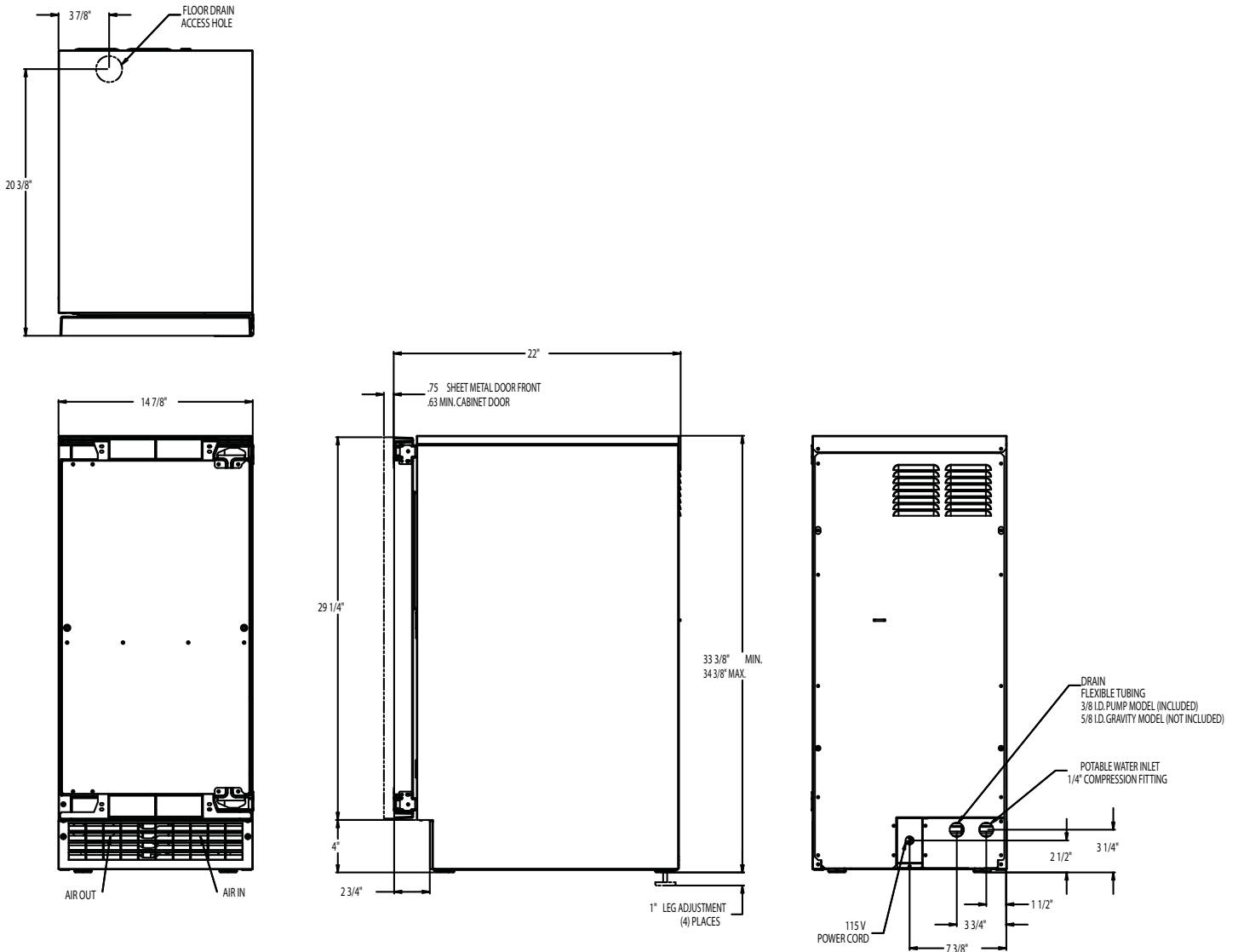

## Installation Notes

**Built In Situations:** If a finished floor is to be installed in the area after the ice machine has been built in, shims the expected thickness of the floor should be installed under the unit to keep the machine level with the planned floor level.

**Installations on a slab:** Use a pump model and pump the water to the point of drainage. Pump models will pump 1 story (10 feet) high.

**Installations over a crawl space or basement:** Either gravity drain or pump model units may be used, if there is not enough room behind the machine for a drain/waste receptacle, the drain will have to be below the floor.

Note: When installed in a corner, the door swing may be limited due to handle contact with the wall or cabinet face.

# SCCG50 & SCCP50 - Outdoor Model Installation and User's Manual

## Water Quality

---

All water, including potable water supplied by municipalities, contains some impurities or minerals. Water absorbs impurities from the air as rain and/or as it flows through the ground. Some of the impurities are solid particles, these are known as suspended solids, and a fine particle filter will remove them. Other impurities are chemically bonded to the water molecules, and cannot be filtered out, these are called dissolved solids.

Ice made by this machine will have a lower mineral content than the water it was made from. This is due to the method of making ice. Purer water will freeze first in the ice making molds. The reason for this is that anything dissolved in water lowers the water's freezing temperature. This concentrates most of the impurities in the ice machine water reservoir where they may form hard deposits known as scale. The machine dilutes the concentration of minerals by over-filling the reservoir during the harvest cycle (with the excess water flowing down the drain). Water use varies with air and water temperatures. Between 2 and 4 pints of water flow into the unit each cycle. Between 1 and 3.5 pints of that rinses the reservoir and goes down the drain.

Some impurities will inevitably remain, and will stick to the parts in the machine, and will cause malformed ice cubes. Eventually, **built up mineral scale can shorten machine life.**

To keep the machine operating properly, these impurities or minerals will have to be regularly dissolved by an acid cleaning, using Scotsman Ice Machine Scale Remover. Directions for this may be found in the section under cleaning.

## Filters and Treatment

In general, it is always a good idea to filter the water. A water filter, if it is of the proper type, can remove taste and odors as well as particles. Some methods of water treatment for dissolved solids include reverse osmosis, and polyphosphate feeders.

### RO Water

This machine can be supplied with Reverse Osmosis water, but the water conductivity must be no less than 10 microSiemens/cm. A reverse osmosis system should include post treatment to satisfy the R.O. water's potential aggressiveness. Deionized water is not recommended.

Because water softeners exchange one mineral for another, softened water may not improve water conditions when used with ice machines. Where water is very hard, softened water could result in white, mushy cubes that stick together.

If in doubt about the water, contact a local point of use water specialist for recommendations on water treatment.

## Installation Overview

The ice machine must:

- be connected to cold, potable water
- be connected to a drain
- be connected to the proper power supply
- be able circulate air through the vents at the front.

---

Note: Do not build in so that the door is recessed.

---

## Door swing change

Note: Prior models had separate hinge brackets and different directions to change swing.

Moving the hinges allows the door to open from either the left or right side. Change swing before attaching door panel.

To change:

1. Remove innermost screw holding each hinge to cabinet, loosen the other.
2. Slide door to the side and remove from cabinet.
3. Remove plug and hinge pocket covers from door.

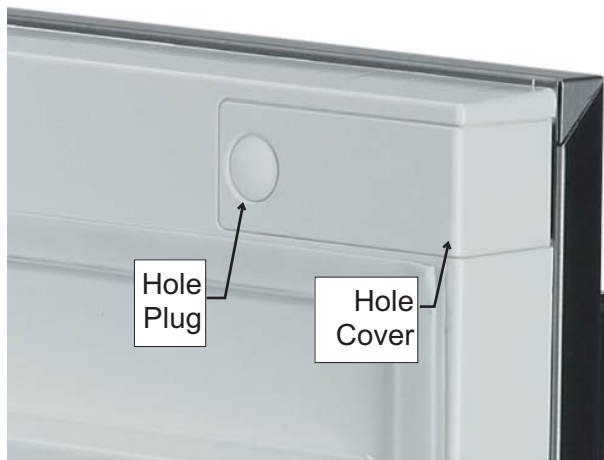

Note: There are either plugs or screws in the holes where the hinges will mount. They must be moved.

4. Remove hole plugs or screws from unit's new hinge locations, set aside.
5. Move screws loosened in step 1 to opposite location.
6. Install screws or plugs removed in step 4 to the unit's original hinge location to fill the holes.
7. Remove the upper hinge from the door and move it to the door's opposite side, bottom location. Secure using the original screws.

Note: If door panel is attached, it must be removed to access hinge screws and to reverse handle position.

8. Remove the original lower hinge and move it to the door's opposite side, upper location. Secure using the original screws.
9. Install pocket covers and hole plugs onto door.
10. Attach the door to the cabinet using the original screws.

## Installation Notes

*Built In Situations:* If a finished floor is to be installed in the area after the ice machine has been built in, shims the expected thickness of the floor should be installed under the unit to keep the machine level with the planned floor level.

*Installations on a slab:* Use a pump model and pump the water to the point of drainage. Pump models will pump 1 story (10 feet) high.

*Installations over a crawl space or basement:* Either gravity drain or pump model units may be used, if there is not enough room behind the machine for a drain/waste receptacle, the drain will have to be below the floor.

Note: When installed in a corner, the door swing may be limited due to handle contact with the wall or cabinet face.

# SCCG50 & SCCP50 - Outdoor Model Installation and User's Manual

## Installation: Water & Drain

The recommended water supply tubing is ¼ inch OD copper. Stainless steel flex or reinforced PCV tube may also be used. Install an easily accessible shut-off valve between the supply and the unit. This shut-off valve should not be installed behind the unit.

Note: Do not use self-piercing type valves.

1. Remove the front service panel.



2. Route the tubing through the right hole in the back to the inlet water solenoid valve inlet.
3. Install a compression fitting on the tubing and connect to the inlet of the solenoid.

## Drains

There are two types of ice machine models, one that drains by gravity and one that has an internal drain pump.

### Drain Pump Model drain installation

1. Locate the coil of 3/8" ID plastic drain tubing secured to the back of the unit.
2. Route the plastic drain tube from the back of the unit to the drain connection point.

**IMPORTANT NOTE:** Often an air gap is required by local codes between the ice maker drain tube and the drain receptacle.

**CAUTION**

Keep unit from  
Freezing

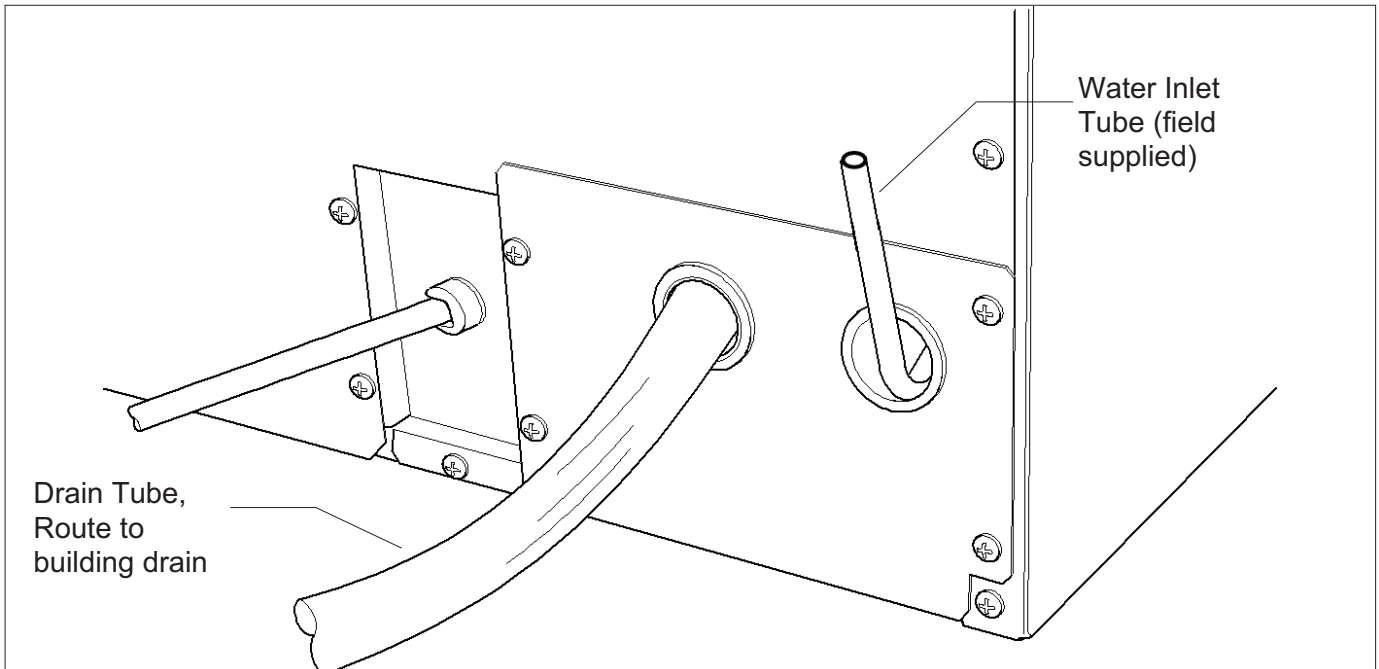

Back View, Drain Pump Model



## Gravity Drain

Caution: Restrictions in the drain system to the machine will cause water to back up into the ice storage bin and melt the ice. Gravity drain tubing must be vented, have no kinks and slope to the building drain. Air gaps are typically required by local code.

1. Place the ice machine in front of the installation opening. Adjust leveling legs to the approximate height.

2. Remove the front service access panel and the upper back panel.

---

Note: If you are connecting a gravity drain model and the drain opening has been located in the floor under the base pan according to the pre install specifications, follow steps 3 through 5 to drain the unit through the base. If not, proceed to step 6b.

---

3. Remove the clamp and barbed elbow and take off the plastic cover in the base pan below the drain hose.

4. Connect a straight 5/8" barbed connector to the drain hose, securing with the clamp removed in step 4.

5. Cut an 8" piece of 5/8" ID X 7/8" OD tygon (clear plastic) tubing. Slide one end of the tube onto the outlet of the barbed connector and secure with a clamp. Leave the other end of the tube lying on the floor of the base pan until the unit is positioned over the floor drain.

6. Route the drain tube. Either a) Insert the drain tube through the base pan into the floor drain or b) Route the drain tube through the left hole in the lower back panel and connect to barbed elbow and secure with a clamp.

7. Reinstall the upper back panel.

8. Reinstall the service access panel. Level the unit.

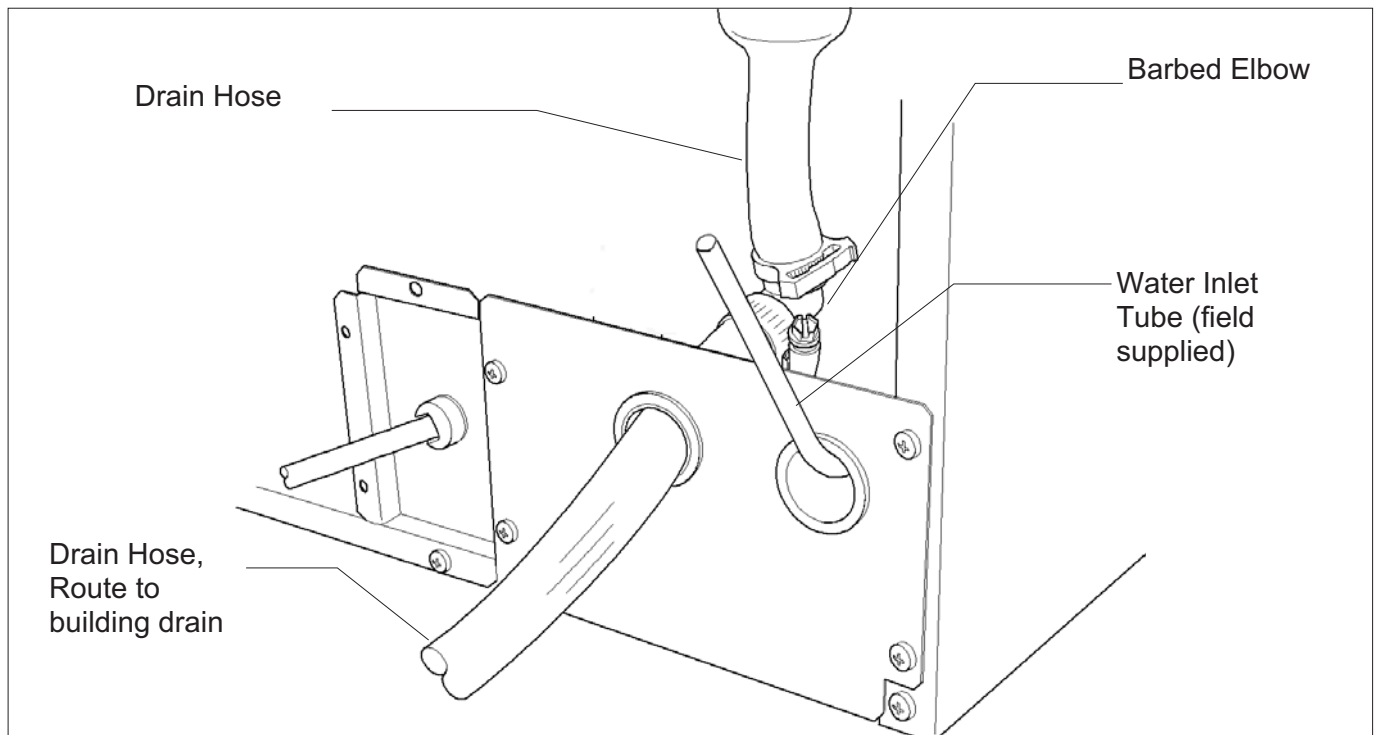

Back View, Gravity Drain Model

# SCCG50 & SCCP50 - Outdoor Model Installation and User's Manual

## Electrical

The ice machine is supplied with a power cord. Do not remove the grounding pin from the cord's plug. Do not use extension cords. Follow all codes. Connect the machine to its own 115 volt, 15 amp circuit.

1. If the electrical outlet for the ice maker is behind the unit, plug in the unit.
2. Position the unit in the installation opening.
3. Turn on the water supply. Make sure that the ice maker is plugged in and the power is on.
4. Slide unit into installation opening, paying careful attention to water supply and drain connections. Do not kink!
5. Pour a couple of quarts of water into the ice storage bin; on drain pump equipped machines the drain pump should start and water should pump out. Check for leaks.
6. Replace the service access panel.
7. Level the unit as needed.

### Installation check list:

1. Has the unit been connected to the proper water supply?
2. Has the water supply be checked for leaks?
3. Has the unit been connected to a drain?
4. Has the drain been tested for flow and leaks?
5. Has the unit been connected to the proper electrical supply?
6. Has the unit been leveled?
7. Have all packing materials been removed from the machine?

### Initial Start Up

1. Turn on the water supply.
2. Switch on the electrical power.
3. Push and release the On/Off switch to start the machine. The Ice Making light next to the On/Off switch will glow Green.



4. Water will begin to flow into the unit. When the reservoir is full, water will start to drain from the machine. After a few minutes the compressor, water pump and fan motor will begin to operate and the first ice making cycle will have begun.

No adjustments are needed.

After about a half hour, ice will fall into the ice storage bin. The machine makes 24 cubes per batch. It is normal for the first batches of ice to melt, that continues until the bin has cooled. It will take 8 to 10 hours of continuous run time to fill the ice bin. When the bin is full of ice, the ice machine will shut off. It will automatically restart when the ice level falls, either from use or normal meltage.

## Use

No special instructions are needed for use. Just take as much ice as you need, the machine will replace it. A scoop is provided, and it can be stored in the machine using the loop of tubing on the right side as a holder.

The machine can be shut off anytime by just pushing and releasing the On/Off button. The machine will shut off at the end of the next cycle. To shut off immediately, push and hold the On/Off button in until the machine stops.

What shouldn't be done?

Never keep anything in the ice storage bin that is not ice. Objects like wine or beer bottles are not only unsanitary, but the labels can slip off and plug up the drain.

Never allow the machine to operate without regular cleaning. The machine will last longer if it is kept clean. Regular cleaning should happen at least once per year, and preferably twice. Some water conditions will dictate even more frequent cleaning of the ice making section, and some carpets or pets will dictate more frequent cleaning of the condenser.

---

Note: The Time to Clean light will switch ON after 6 months of use. It will remain ON until the ice making system is cleaned using the process on page 12.

---

Noise:

The ice machine is designed for quiet operation, but will make some noise during the ice making cycle. During a freezing cycle, it is normal to hear the fan moving air and the water pump circulating water. Ice hitting the bin or ice in the bin can be heard during harvest.

If ice making noise is objectionable, an appliance grade timer can be added to the power supply. Set the timer to turn the machine off at the time(s) of day when the noise is most objectionable.



Normal cubes are tapered cylinders. If the cubes are ragged and mis-shaped, mineral scale must be removed from the ice making system

## **SCCG50 & SCCP50 - Outdoor Model Installation and User's Manual**

### **Maintenance**

---

There are 5 things to keep clean:

1. The outside cabinet & door.
2. The ice storage bin.
3. The condenser.
4. The ice making system.
5. The ice scoop.

How to clean the cabinet.

Wipe off any spills on the surface of the door and handle as they occur. If anything spilled on the door or gasket dries onto the surface, wash with soap and warm water to remove.

How to clean the ice storage bin.

The ice storage bin should be sanitized occasionally. It is usually convenient to sanitize the bin after the ice making system has been cleaned, and the storage bin is empty.

A sanitizing solution can be made of 1 ounce of household bleach and two gallons of hot (95°F. – 115°F.) water. Use a clean cloth and wipe the interior of the ice storage bin with the sanitizing solution, pour some of the solution down the drain.

Allow to air dry.

## How to clean the condenser and winterize.

### Condenser cleaning

The condenser is like the radiator on a car, it has fins and tubes that can become clogged with dirt and lint.

Note: Outdoor operation can lead to rapid build up of debris, such as leaves and other vegetation. The condenser will need to be frequently checked for debris. Clean it whenever the fins are obstructed.

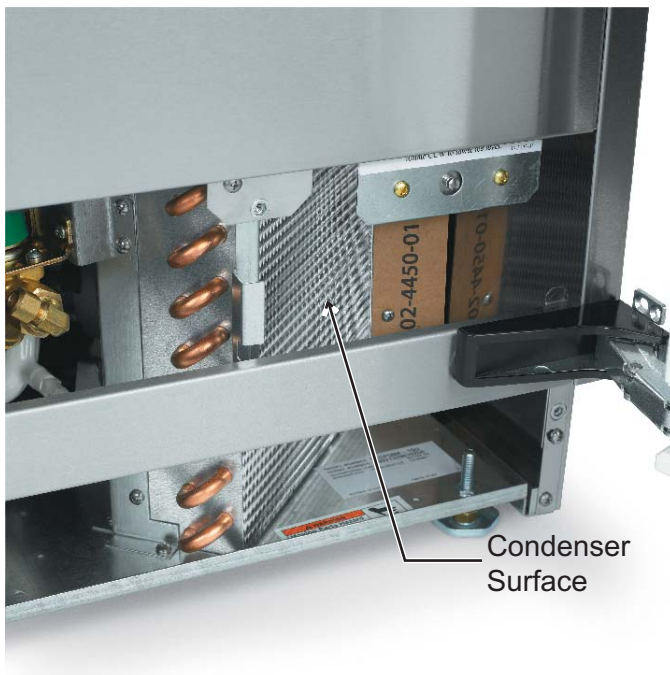

To clean:

1. Remove the kickplate and front service panel.
2. Locate the condenser surface.
3. Vacuum the surface, removing all dust, dirt and lint.

Caution: Do not dent the fins.

4. Return the kickplate and front service panel to their original positions. Fasten them to the cabinet using the original screws.

### Winterizing

1. Clean the ice making system.
2. Open the door and push and release the On/Off switch to turn the machine off.
3. Turn off the water supply.
4. Drain the water reservoir by removing the rubber cap under the reservoir - it's near the back wall of the ice storage bin.



5. Disconnect the incoming water line at the inlet water valve.
6. Open the door, push and release the on/off switch to turn the machine on.
7. Blow air through the inlet water valve; a tire pump could do the job.
8. Drain pump models should have about 1/2 gallon of RV antifreeze (propylene glycol) poured into the ice storage bin drain.

Note: Automotive antifreeze must NOT be used.

9. Switch off and unplug the machine.

## SCCG50 & SCCP50 - Outdoor Model Installation and User's Manual

### How to remove scale from the ice making system.

---

1. Scoop out all of the ice, either discard it or save it in an ice chest or cooler.

2. Press and HOLD the On/Off button in for 3 seconds until the Green light goes out.



3. Press and HOLD the both the Clean-Reset and On/Off buttons for 5 seconds. The Time to Clean light will blink on and off.

4. Pour 4 ounces of Scotsman Ice Machine Scale Remover (available from a local Scotsman Distributor or Dealer) into the ice machine reservoir.



Pour Scale Remover Here

5. Operate the machine for about ½ hour.

6. Push and release the On/Off switch. The machine will begin to flush out the cleaning solution.

7. Operate the machine for another ½ hour.

8. Push and release the On/Off switch. The machine will stop the cleaning process.

9. Pour a gallon of hot (95°F. – 115°F.) water into the bin to flush out the drain.

10. Clean the bin liner of mineral scale by mixing some ice machine scale remover and hot water, and using that solution to scrub the scale off of the liner.

11. Rinse the liner with hot water.

12. Sanitize the bin interior.

13. Replace the ice removed in step 1.

14. Push and release the On/Off button to restart ice making.

The ice scoop should be washed regularly, wash it just like any other food container.

## **What to do before calling for service**

---

Ice cubes are incompletely formed

- Clean the ice making system

Low capacity

- Check for restricted drain or standing water in the bin
- Clean the air cooled condenser fins

No ice

- Check on-off switch
- Check electrical breaker
- If the Check Water light is flashing Red, check water supply. The control system checks for water every 20 minutes. When the water supply is restored, the machine will automatically restart ice making.

Time to Clean light is on

- Clean the ice making system.

# **SCOTSMAN ICE SYSTEMS**

775 Corporate Woods Parkway

Vernon Hills, IL 60061

800-726-8762

[www.scotsman-ice.com](http://www.scotsman-ice.com)