



BATVIEW 2 State of charge controller

12V-24V
Code REYA : 399032



BEFORE OPERATION THIS MANUAL CONTAINS VITAL AND ESSENTIAL INFORMATION. IN ORDER TO AVOID ELECTRICAL SHOCKS OR OTHER DAMAGE, THE OWNER SHOULD READ AND UNDERSTAND THIS IMPORTANT DOCUMENT BEFORE OPERATING THE CHARGER.

In the event of any problems or misunderstandings, please contact mdp electronics.

This equipment is not designed for use by people (including children) with diminished physical, sensorial or mental capacities or people without experience or knowledge of such equipment, unless they have received prior instruction in the use of the equipment from a person responsible for their safety or are under the supervision of such a person. Ensure that children are supervised in order to prevent them playing with the device.

This equipment contains components that may cause electric arcs or sparks, when connecting cables, for example. To prevent any risk of fire or explosion, do not install this equipment close to flammable materials, liquids or gases.



Installation precautions

Afin de prévenir tout risque de surchauffe ou de dommage irréversible sur le matériel, veuillez à suivre de manière impérative et rigoureuse les recommandations ci-dessous.

- ▶ This device must not be exposed to running water, water spray or dust of any kind.
- ▶ Under no circumstances should this device be seen as a toy.
- ▶ Therefore, it should not be left in the hands of a child.



Connection precautions

To prevent any risk of electric shock or irreversible damage to the equipment, you should comply strictly with the following recommendations.

The installation to which the device is connected must comply with the applicable regulations.

To prevent parasite heating, ensure the cable cross-sections are correct and the connectors are suitably tightened.



Activation precautions

To prevent any risk of electric shock during activation or operation, you should comply strictly with the following instructions.

Obviously, the product must not be dismantled and the housing assembled correctly.

This device complies with the applicable regulations governing transmitted interference and immunity from external disturbances.

CONTENTS OF BATVIEW2 PACKAGING

Please check the contents when opening the BATVIEW packaging



- ▶ A VISION 5 housing and its graphic display



- ▶ Chrome plated trim

Batview2-rev 01

Batview2-rev 01

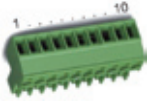

- ▶ A angled connectors
10 points



- ▶ A angled connectors
6 points



- ▶ A 300A 100mV shunt



- ▶ A temperature sensor



- ▶ A bag of fixing screws



- ▶ A user manual

GENERAL CHARACTERISTICS

The BATVIEW2 is a battery management system that allows the voltage of 4 different sets of batteries and the amperage of 2 different sets of batteries to be measured (1 shunt supplied, a second optional shunt is available).

A calculation algorithm based on the Peukert exponent allows the charge percentage for two sets of batteries to be displayed (if a second optional shunt is used).

The Peukert coefficient allows the actual capacity of a battery to be estimated. For example, a capacity of 100Ah is applicable for a C/20 discharge rate, i.e. 5A per hour for 20 hours at an ambient temperature of 20°C. However, this same battery will provide less than 100Ah if the amperage used exceeds 5A, or more if the amperage is lower.

It is therefore an intelligent battery management system, which is able to automatically adapt to any consumption or charge on one or two house batteries, in such a way as to provide an extremely precise indication of the remaining charge percentage.

The BATVIEW2 is easy to connect and automatically recognises a 12V DC or 24V DC supply voltage when it is powered on.

The BATVIEW2 is equipped with a non-volatile memory allowing the configuration settings to be stored, even when there is no power, when it is reactivated.

The BATVIEW2 is not sensitive to cycling effects as it automatically detects floating mode, which means that the batteries are fully charged. It is therefore not affected by measurement drift over the course of successive charging and discharging cycles, which, for other management systems on the market, results in a need to completely reinitialise the charge status.

The shunt supplied is made from a special alloy, which allows a voltage drop, calibrated in mV (converted into amps by the management system), to be measured. This value is etched on the shunt as is the maximum amperage that can flow through it. This maximum amperage is 300A for a maximum of 5 minutes. The permanent amperage that can flow through this type of shunt is two thirds of this value (200A).

INFLUENCE OF THE PEUKERT EXPONENT:

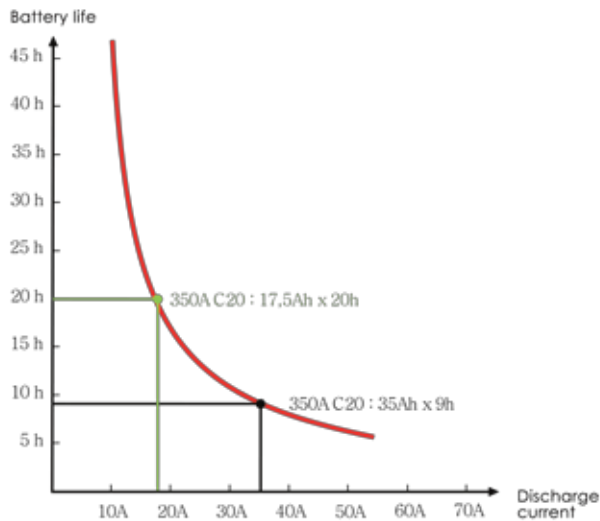

The Peukert exponent allows the life of a battery, which is not linear, to be better estimated.

In the example opposite, for a 350A battery, with a discharge capacity of 20 hours (C20) stated by the battery manufacturers, we could actually expect use of 17.5A per hour for 20 hours (in green on the graph).

If this discharge was linear, it could be argued that in 10 hours we could obtain 35A per hour, except that in reality, the result is 9 hours, the Peukert exponent allowing this to be determined. The remaining capacity, according to the BATVIEW2, expressed as a charge percentage, is therefore as accurate as possible compared with the reality.

Quick installation guide

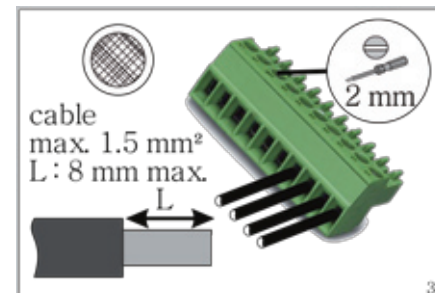
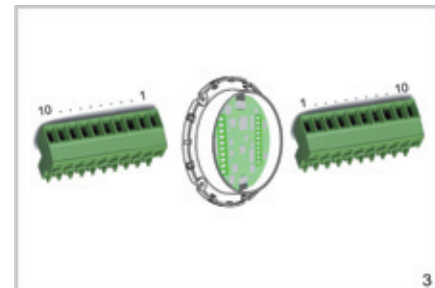
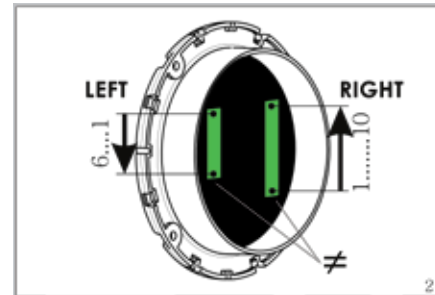
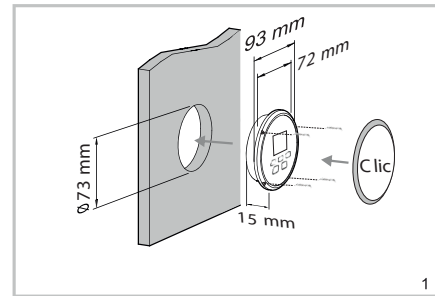

List of terminals

- 1 Dry alarm contact (normally open)
- 2 Dry alarm contact (common)
- 3 Dry alarm contact (normally closed)
- 4 BAT.2 temperature sensor (no direction)
- 5 Common temperature sensors for BAT.1 and 2
- 6 BAT.1 temperature sensor (no direction)

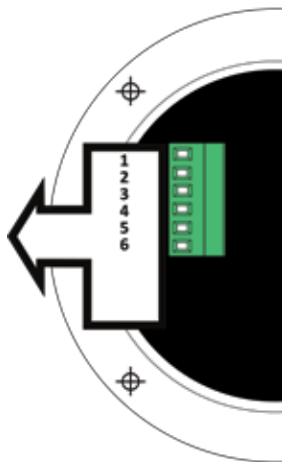

Wiring :

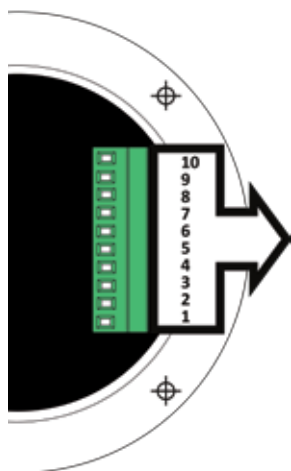

- 10 SHUNT.1, measuring screw on battery 1 side
- 9 SHUNT.1, measuring screw on the distribution side
- 8 Common negative or ground
- 7 BAT.1, SHUNT.1 measuring screw on the distribution side
- 6 BAT.3, positive terminal for battery 3
- 5 BAT.4, positive terminal for battery 4
- 4 BAT.2, SHUNT.2 measuring screw on the distribution side
- 3 Not used
- 2 SHUNT.2, measuring screw on the distribution side
- 1 SHUNT.2, measuring screw on battery 2 side

PRECAUTIONS TO BE TAKEN FOR INSTALLATION

▶ All connection errors (polarity reversals in particular) cause irreversible damage to the equipment. You should, therefore, pay particular attention to this.

▶ For the measuring wires for each shunt (right hand terminal 1&2, 9&10), use a shielded twisted pair cable (otherwise there is a risk of measurement being frozen), tin-plated with ring terminals (\varnothing 4 mm). Use the same pair for the 2 measuring screws (- and +) for the same shunt.

▶ A cross-section of 1 mm², if possible tin-plated, is recommended for the other connected wires. The use of shielded cable is not necessary in this case, except if there is the potential for disturbance by the wiring for other equipment.

▶ The external shunt for current measurement must be positioned as close as possible to the positive on the battery, i.e. the + BAT.

▶ An error in the direction of the 2 jumper wires between one of the shunts and the BATVIEW2 will result in an error in the direction of the current, i.e. an arrow pointing down during charging and up during discharging, as well as incorrect information on the quantity of power remaining. Simply reverse the 2 wires in question in order to restore the correct direction and resolve the problem.

1 SHUNT BATVIEW2 WIRING

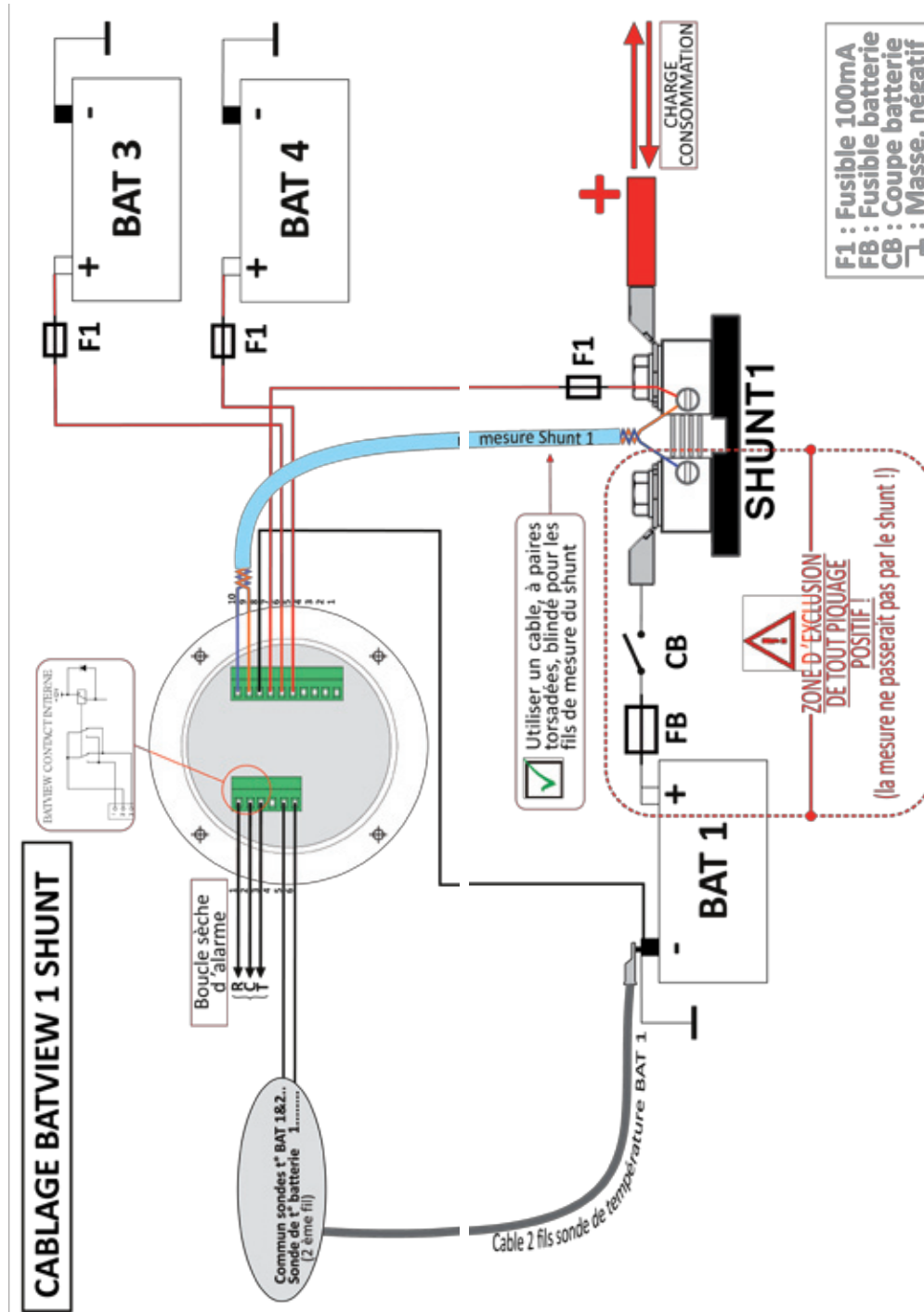

Batview2-rev 01

Batview2-rev 01

2 SHUNTS BATVIEW2 WIRING

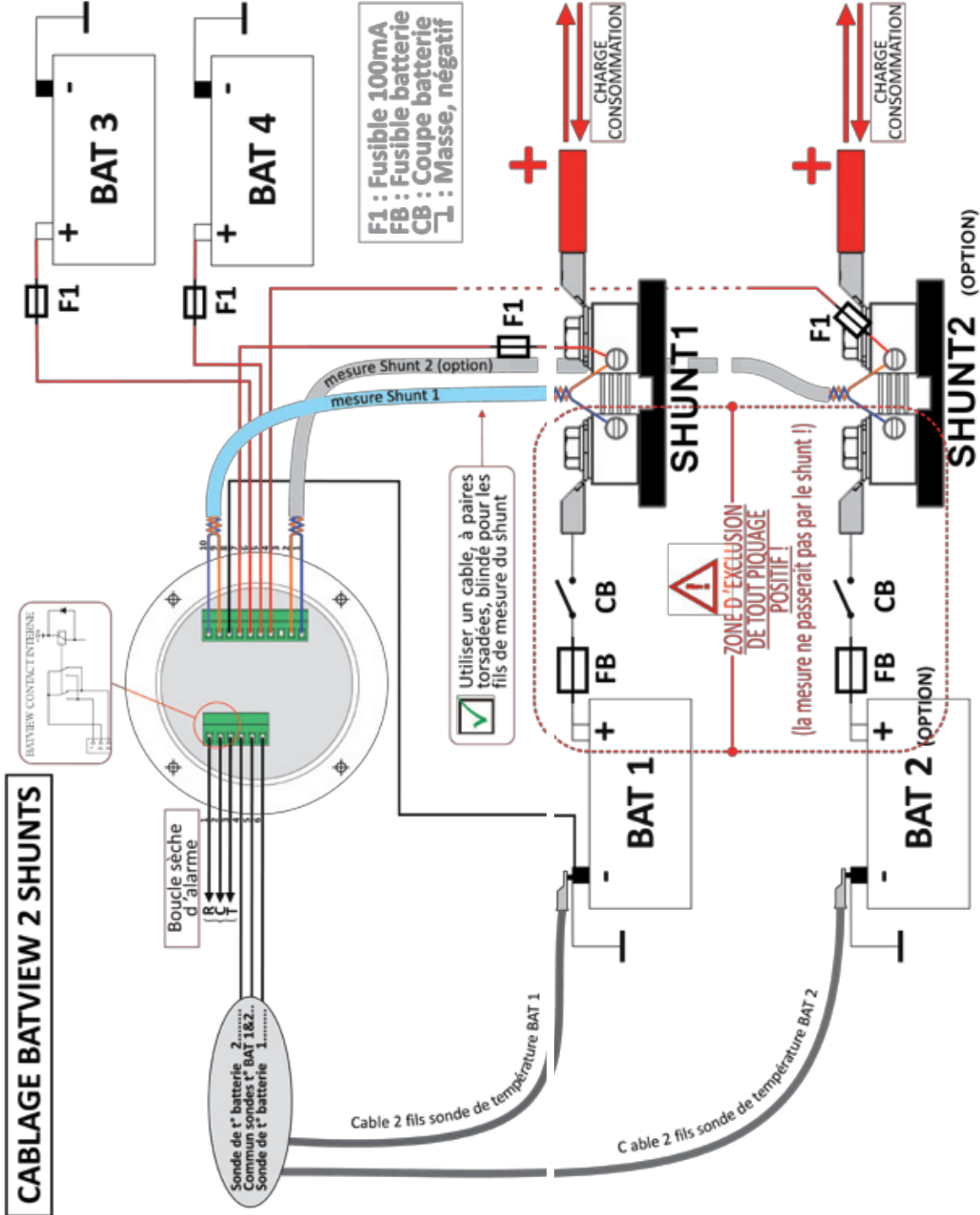

Batview2-rev 01

Batview2-rev 01

General	
Battery capacity	Between 30 and 5000Ah
Operating t°	-10°C to +50°C
Storage t°	-20°C to +70°C
Relative humidity	10% to 70% without condensation
Circuit board moulded and protected	Instrument à encastrer Ø 93mm
Presentation	Instrument for embedding/mounting Ø 93 mm
Housing	Ø 72 mm (use a Ø73 mm hole saw)
Depth 30 mm (including connections)	93 x 30mm
Mounting	4 screws supplied
Overall dimensions (Ø x D)	93 x 30 mm
Weight	< 500 g
Connections	Batteries and shunts by 10-point screw terminal for wires of 1.5 mm ² max
Shunt	300A 100mV
Temperature sensor	NCT moulded into a Ø 8 mm terminal, to be attached to the battery terminal

Power supply	
Voltage	12V DC or 24V DC (+/-25%), automatic selection
Consumption	10mA to 30mA (Alarm) depending on the operating mode

Display	
Type of display	OLED graphic display
Selection mode	5-button keypad

Alarms	
Battery under-voltage	Active as soon the voltage of BAT.1 2 3 or 4 < 11V (or 23.5V)
Can be set at between 10V and 12V (or between 18V and 24V)	Active dès que la tension de BAT.1 2 3 ou 4 > 16V (ou 32V)
Battery overvoltage	Active as soon as the voltage of BAT.1 2 3 or 4 > 16V (or 32V)
Battery temperature	Active as soon as the temperature of BAT.1 or 2 > 60°C

Tested settings	
Battery voltage	8V DC to 35V DC (measuring accuracy +/-2%)
Battery current	Permanent +/-350A (measuring accuracy +/-5%)
Battery temperature	-10°C to +100°C (measuring accuracy +/-5%)
Remaining battery life	0% to 100% (measuring accuracy +/-10%)

IMPORTANT when first powered on

Disregard the initial information provided on the basis of factory settings.

Adjust the type and capacity settings for different sets (see SETTINGS MODE).

For increased accuracy when measuring current, it is necessary to reset the current. To do this, ensure that no current is flowing through the shunt or shunts (no battery power consumption or charging in progress).

Disconnect then reconnect the BATVIEW2.

The BATVIEW2 produces an estimate of the remaining capacity, in Ah, by measuring the no-load voltage of the batteries. This is only an initial estimate.

To completely initialise the device, simply perform a first charging cycle, preferably by using the built-in charger. 100% initialisation becomes effective once the batteries have been charged (VBAT > 13.2V or 13.6V depending on the chosen technology and once the charging current has been reduced to zero).

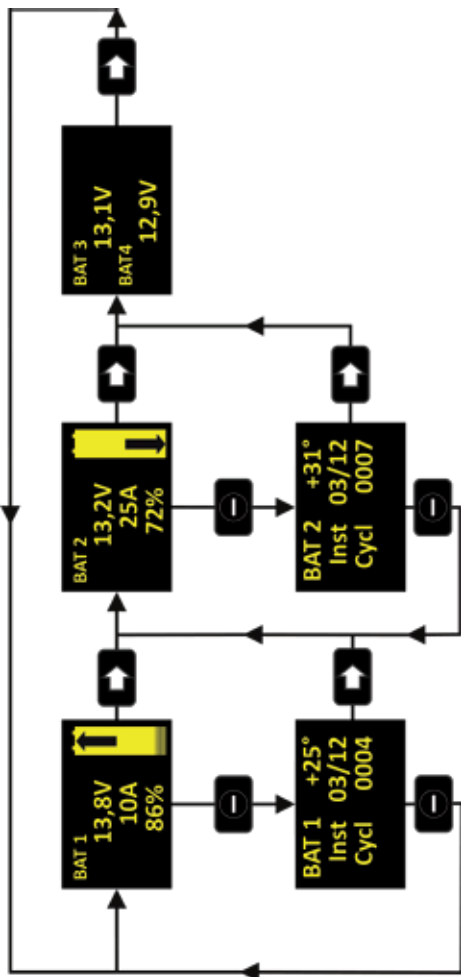
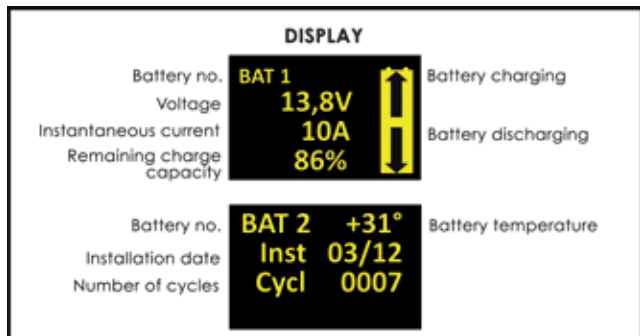

Settings mode

Factory settings (default settings):

- ▶ Temperature expressed in degrees Celcius.
- ▶ A single set of batteries.
- ▶ Capacity of house batteries: 340Ah.
- ▶ Type of shunt: 300A.
- ▶ Low battery voltage alarm: 11.0V.
- ▶ Type of house batteries: With free electrolyte (FREE)

Factory settings are operational until the user enters his/her own settings.

To save any changes, quit by pressing and holding the SET button. The configuration settings are saved in a non-volatile memory, as a replacement for the factory settings.

These settings will, therefore, be automatically applied when the device is next powered on.

It should be noted that the device automatically leaves settings mode 45 seconds after the last time the SET button is pressed without saving the modified settings in a memory.

ENTER THE SETTINGS MENU
PRESS > 2 SECONDS SET

EXIT THE SETTINGS MENU &
SAVE SETTINGS
HOLD SET

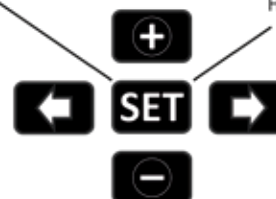

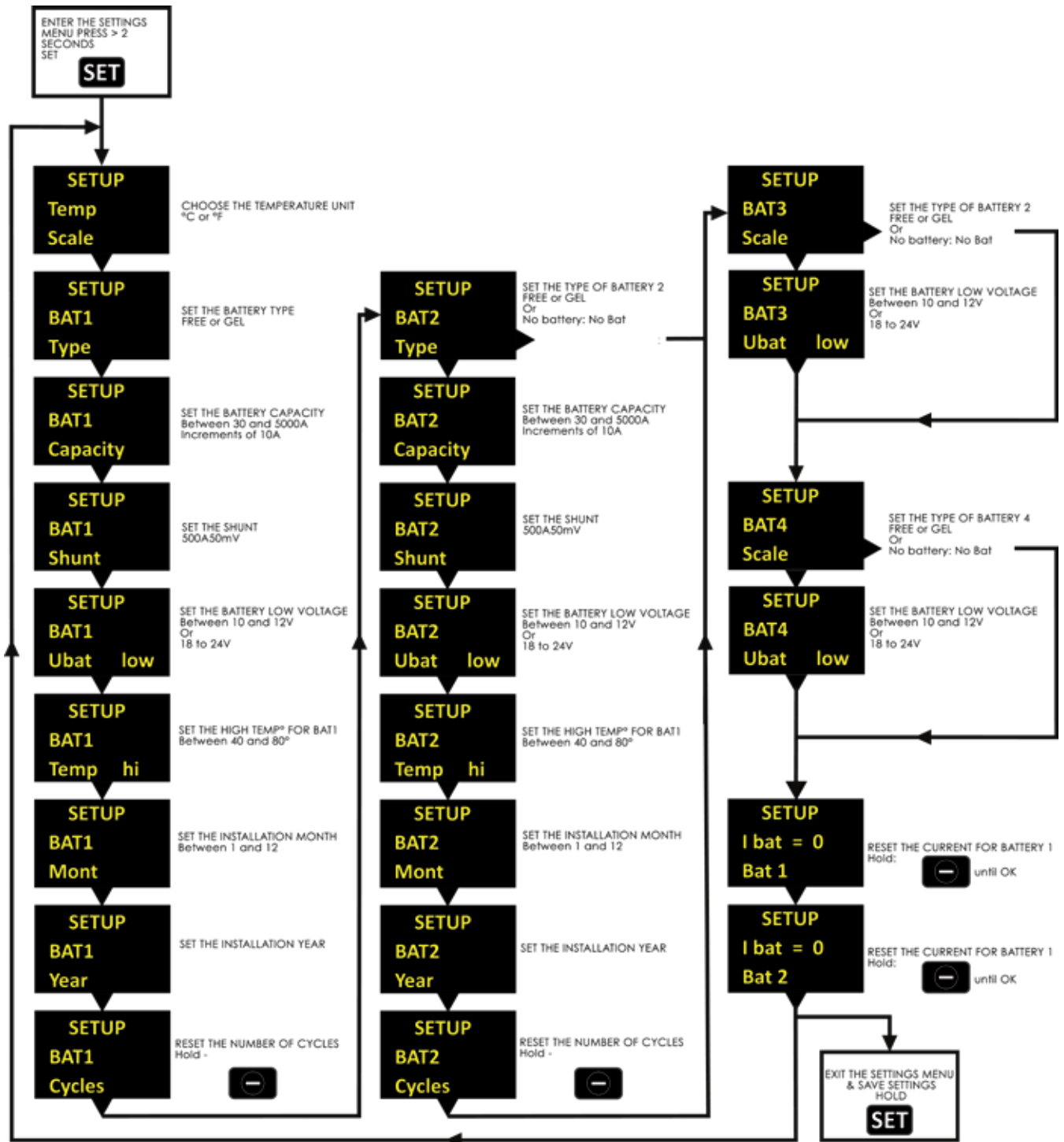

Set the Alarme mode

The device switches to Alarm mode when it detects

- ▶ An undervoltage fault on any one of the 4 sets of batteries.
- ▶ An overvoltage fault on any one of the 4 sets of batteries.
- ▶ A temperature fault on sets 1 or 2.
- ▶ A low capacity fault on sets 1 or 2.

This mode is signalled by a flashing display indicating the type of fault detected.

Batteries 1 and 2	
ALARM BAT(No.) Vbat LO	Battery undervoltage alarm (No.)
ALARM BAT(No.) Vbat HI	Battery overvoltage alarm (No.)
ALARM BAT(No.) Temp HI	Battery temperature alarm (No.)
ALARM BAT(No.) Capa LO	Battery low capacity alarm (No.)
ALARM BAT(No.) CTN 1	T° sensor battery fault alarm (No.)

Batteries 3 and 4	
ALARM BAT(No.) Vbat low	Battery undervoltage alarm (No.)
ALARM BAT(No.) Vbat high	Battery overvoltage alarm (No.)

This mode results in the closure of an RCT dry loop (terminals 1, 2, 3). The maximum switchable current for the dry loop relay is 1A at 36V DC max.:

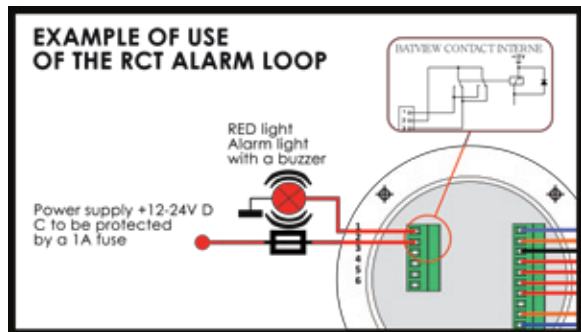
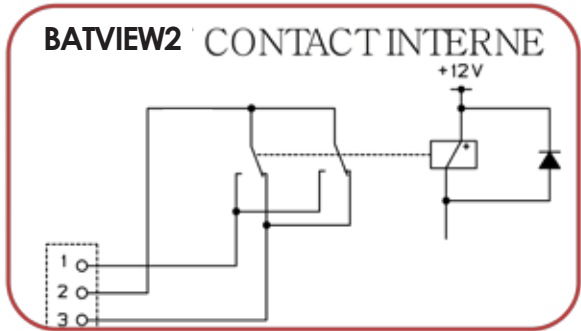

Return to "Normal" mode is automatic as soon as the fault has disappeared.

Pressing "SET" allows you to momentarily return (for 10 seconds) to "Normal" mode to allow you to view various settings. If the fault persists, a return to "Alarm" mode is automatic.

For further information or assistance,
please contact:

REYA SAS

2599 Route de la Fènerie
06580 Pégomas
FRANCE

Tél : (33) 0 493 904 700

Fax : (33)0 493 902 440

e-mail : export@reya.com

www.reya.com