

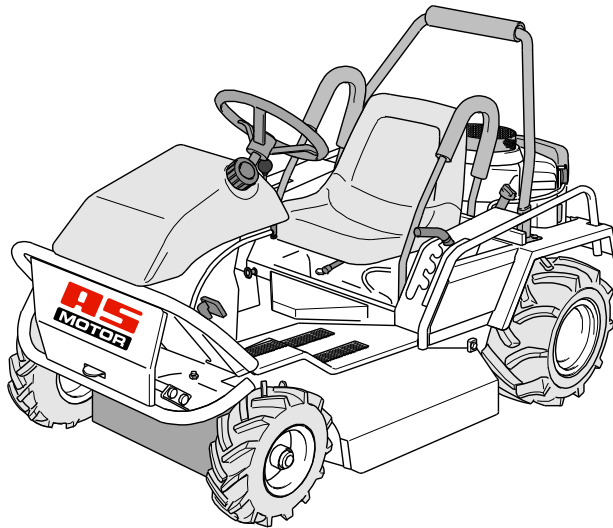

Operating Instructions



Ride-on Allmäher®

AS 900 ENDURO + AS 915 ENDURO

From serial number: AS 900: 021415010001, AS 915: 018215010015
Issued: 09 April 2015, V21.0
EN-Translation of the Original Operating Instructions

Preface

Please fill in all data referring to your device. When ordering spare parts, provide your dealer with the device and engine number.

Serial number:

Please adhere the sticker from the warranty card here.

Engine number:

Date of purchase:

Address of dealer:

Dear customer:

Congratulations on your purchase. You have acquired a reliable quality product by "AS-Motor Germany".

This product has been manufactured according to modern manufacturing methods and comprehensive quality assurance measures. Only when you are satisfied with your device, we have attained our goal.

Read these operating instructions carefully and attentively so that your device operates smoothly and you and others are safe from any hazards. If you have questions concerning your device, please contact your dealer or call our customer service (telephone +49/(0)7973/9123-0). For international AS partners, please see: www.as-motor.de/worldwide.

"AS-Motor Germany" wishes you much joy with your new device.

Intended use

The device is exclusively intended for cutting grass or similar vegetation in agriculture, forestry, and landscape conservation.

Only use attachments and cutting tools authorised by "AS-Motor Germany".

Any use exceeding this purpose is inadmissible. The manufacturer is not responsible for any damage resulting from this. Observe the required maintenance and repair measures.

The user of the device is responsible for accidents or damage to other persons or their property!

The device **must not** be used:

- To cut hard objects, rocks, rubble, or pieces of wood.
- To trim bushes, hedges, and shrubbery.
- To cut plants on rooftops.
- To clean (vacuum) footpaths.
- As shredder for shredding tree and hedge cuttings.
- As drive unit for work tools and any type of tool sets that are not authorised by "AS-Motor Germany".

The device is not licensed for driving on public roads.

Contents

Preface	2	Oil pressure switch.....	18
Intended use	2	Towing	18
Explanation of the symbols	4	Driving	19
Symbols in the instructions	4	Braking	19
Symbols on the device.....	4	Driving	19
Safety instructions	6	Reversing.....	19
Get informed!.....	6	Differential lock	19
User restrictions and hours of operation.....	6	Switching off and parking	20
Safe handling of fuel	6	Maintenance and cleaning	21
Check the device prior to use.....	7	Preparations	23
Use caution during operation	7	Cleaning the device	23
Prior to mowing.....	7	General inspection.....	23
Use caution when mowing	7	Operating hours counter	23
Caution when using accessories.....	9	Checking the parking brake.....	24
When work is completed.....	9	Checking the foot brake	24
Hydraulic components	9	Grease lubrication.....	24
Use caution during maintenance and repair	9	Checking the blade	24
Device description	11	Maintaining the engine.....	26
Control elements	12	Checking the engine oil level.....	26
Front area	12	Checking the spark plug.....	26
Brake	12	Maintaining the air filter	27
Control lever at seat.....	13	Checking and charging the battery.....	27
Drive/idle mode.....	14	Hydrostat transmission.....	27
Fuel valve	14	Storage	28
Transport	14	Storing the device	28
Transport on pallets	14	Longer storage.....	28
Transport of ready-to-use device	14	Restarting	28
Assembly	15	Spare parts	28
Scope of delivery	15	Wear parts	28
Unpacking.....	15	Disposal	28
Mounting.....	15	Warranty	29
Information on mowing	16	Troubleshooting	30
Prior to starting	17	Technical data	34
Checking the oil level	17	Accessories	35
Fuel	17	Declaration of conformity	36
Tanking up.....	17		
Adjusting the seating position.....	17		
Starting	17		
Safety switches.....	17		
Starting the engine.....	17		
Engaging the blade	18		

Explanation of the symbols

Symbols in the instructions

In these operating instructions, the following symbols are used to denote special dangers.



Warning.
These symbols denote special dangers.



Prohibition sign.
These symbols denote inadmissible procedures.



Directive sign.
These symbols denote required protective measures.

Symbols on the device

The following symbols are placed on the device to inform you must be careful and attentive when using the device:



Working with the device requires extreme caution. The quickly rotating blade of the device can cause life-threatening injuries or major property damage

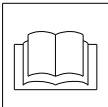

Read the operating instructions before you use the device.

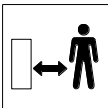

Make sure that no one is within the danger zone of the device.



Hot surfaces or components. Do not touch the engine or the silencer.



Risk of injury due to running belt drive! When the engine is running, never reach into the belt drive.

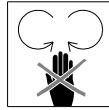

Risk of injury caused by rotating components!



Danger of bursting while tires are inflated. Observe the admissible tire pressure (see Technical data).



The device generates poisonous exhaust fumes as soon as the engine is running. Some of these gases are odourless and invisible. Never let the engine run in closed rooms.



Risk of tipping!



When positioned sideways to the slope, the device is stable up to 20° (in accordance with the standard measuring method).

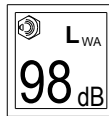

Sound level on the device.



Noise is causing health problems. Use personal ear protection to avoid hearing damage.



Warning!

Risk of injury caused by rotating blades or parts.

Objects can be ejected. Make sure that no one is within the danger zone of the blade (at least 50 metres).

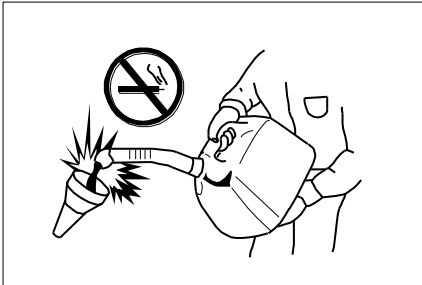

Warning!

Explosion hazard! Keep the fuel away from ignition sources and do not smoke while handling the device.

Observe the safety instructions regarding the fuel!

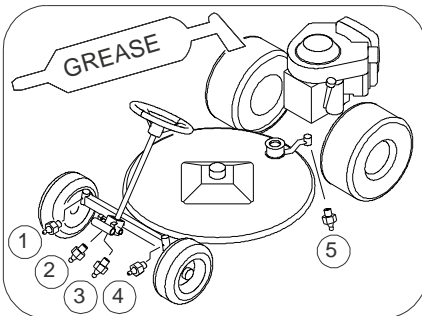

Lubrication chart

Position of grease nipples for grease lubrication. Observe the maintenance instructions.

Type plate

The type plate on the device provides you with information on the device type and the technical data.

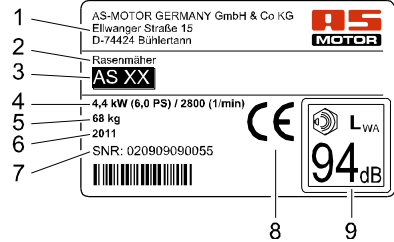

- 1 Name and address of the manufacturer
- 2 Device designation
- 3 Type designation
- 4 Rated power output in kW / engine speed
- 5 Weight
- 6 Year of manufacture
- 7 Serial number
- 8 CE marking
- 9 Sound level L_{WA}

Safety instructions

Get informed!

For your safety, read these operating instructions with care. Familiarize yourself with the control elements and the proper use of the device. Share these operating instructions with other users of the device.

Before you use the device for the first time, let the dealer instruct you regarding safe use.

Get familiar with the device in a wide, open and flat terrain first.

User restrictions and hours of operation

Never allow children or persons who are not familiar with the operating instructions to use the device. Persons under 18 years of age may operate the device only under proper supervision. Local regulations determine the minimum age of the operator and the operating times.

Unsuitable for operation of the device are persons who

- are under the influence of alcohol, drugs or reaction retarding medicines.
- have physical and mental/emotional impairments.
- are tired or sick.



People fitted with pace makers are not allowed to touch any current carrying parts of the ignition system.

Safe handling of fuel



Danger!

Fuel is toxic and highly inflammable.



Danger of fire and explosion!

Keep the fuel away from ignition sources and do not smoke while handling the device.

Do not inhale fuel vapours; they are dangerous to your health.



Use gloves and avoid skin contact with the fuel.

Fuel up outdoors only when the engine is cool and not running. Use a filler or funnel.

Do not spill any fuel and do not let the fuel get into the canalisation or ground water.

If you spilled fuel, do not start the device until the fuel vapours have evaporated (wipe dry). Move the device away from the area where the fuel was spilled.

Always close the tank cap securely and do not open it while the engine is running or the device is still hot.

Drain the fuel tank only when outdoors. Use a suitable container or run the tank empty.

Keep the fuel away from children and store it in a suitable container in a dark, cool, and dry location.

Never park the device with fuel in the tank inside a building where fuel vapours could come in contact with open fire or sparks.

Immediately replace a damaged fuel tank or tank cap (authorised dealership).

First aid

When swallowing fuel or inhaling fuel vapours, do not force vomiting and immediately consult a doctor.

In case of skin contact, immediately wash with water and soap. Change your soiled clothing as soon as you can.

Measures in case of a fire

In case of a fire, use foam, dry powder extinguisher, or carbon dioxide (CO₂). Never douse with water!

Check the device prior to use

Prior to each use, carry out a visual inspection of the blade, protection flap, drive and fastening parts for proper condition and firm seating.

Never use the device when covers, impact protection or protection flaps are defective or not installed.

Do not remove, change or override any safety devices or control elements.

Observe the maintenance instructions and replace damaged or worn parts immediately.

Check the blade brake for proper function by switching off the blade clutch. The blade must come to a standstill from full speed within less than 5 seconds.

Check the parking brake for proper function (see Maintenance).

Use caution during operation

Do not start the engine

- if fuel was spilled.
- in closed or poorly ventilated rooms (danger of poisoning!).
- if there are other persons nearby.

After every stop and before you shut down the engine, actuate the parking brake. This prevents the device from accidentally rolling away.

Do not touch the exhaust, the engine, and the gearbox. They become very hot during operation and you can get burned. Resulting unintentional movements constitute an additional injury hazard.

Switch off the blade and wait until the blade comes to a standstill,

- when you drive on surfaces other than grass.

Switch off the engine and wait until the blade comes to a standstill and remove the ignition key,

- before you transport the device.
- if you step away from the device, even for just a short time.
- before you clean or check the device or before you carry out work on the device.
- before you unblock or unclog the discharge area.

Prior to mowing

Personal protective measures



While mowing, always wear sturdy footwear with good grip, long trousers, and gloves. Do not mow in open sandals or bare feet.



Noise is causing health problems. Use personal ear protection to avoid hearing damage. Wear safety glasses and headgear.

Ask your specialised dealer about suitable protective equipment.

Preparing the mowing area

Prior to mowing, carefully check the perimeter of the lawn. Remove rocks, pieces of wood, bones, wires, and other objects that could be picked up and thrown out by the device.

Use caution when mowing

Risk of injury

Stay within shouting distance to other people who can help you in case of an emergency.



Danger!

Risk of injury caused by thrown out objects.

Never mow while persons, children, pets, or property are in the vicinity.



The area in front of and to the right of the device is especially dangerous.

Keep your hands and feet away from the rotating parts.

Only mow during daylight or with adequate artificial lighting. Never mow in the event of uncertain weather conditions and risk of lightning.

Be especially carefully when mowing on soft ground, nearby landfills, ditches and dikes.

Do not transport any person on the device.

Be extremely cautious when moving in reverse.

Pay attention to traffic when working close to roads.

When using the device over a longer period of time, vibrations can cause disturbances in the blood supply of the hands. A generally accepted usage time cannot be determined. Use gloves.

Take breaks on time.

Have an authorised service centre check the device immediately

- if the blade hit an object.
- if the device starts to vibrate unusually severely.

Caution when mowing slopes



Danger!

If the device, while in use, stops in steep terrain or the engine cuts out, the device can roll away.

Immediately actuate the parking brake to prevent the device from rolling away.

Observe the information regarding the oil pressure switch in chapter Starting.



When mowing slopes, there is a risk of slipping and tilting!

- Do not mow excessively steep slopes. For safety reasons, use the device only on less than 20° slopes.
- Use a clinometer if you are not familiar with the slope (see accessories).
- Never unlock the drive at the slope because the device can roll away.
- Always mow up- and downhill, never in horizontal direction.
- Always move upwards first. If you are unsuccessful at moving upwards first, you must not mow the slope. Never move downwards if you were not successful at moving upwards.
- Be extremely cautious when changing the direction.
- Do not turn on a slope.
- Only mow when you are familiar with the terrain and the terrain is clear of obstacles.
- Pay attention to bumps, holes, and other visible hazards.
- Do not mow close to danger zones (e.g. walls, steep declines, etc.).
- Prior to entering the slope, always actuate the differential lock. Move on slopes only when the differential lock is actuated.
- Always keep the speed low when moving on slopes.
- Do not start abruptly and do not brake abruptly.
- Hold the steering wheel tightly so that the device does not swerve.

Only park the device on flat surfaces.

The drive has good braking efficiency which can only provide sufficient grip on a non-slip surface.

If the mower starts to slide you can regain control by actuating the brake. Uncontrolled handling is due to:

- poor tire grip.

- speeding.
- abrupt braking.
- an inappropriate task for the device.
- poor knowledge of the area.
- slope angles that are too steep.

Risk of tilting

If the wheels facing uphill encounter obstacles such as roots, branches, rocks, bumps, etc., the mower can tilt or slide.

Keep in mind that all attachments and loads increase the risk of tilting.

Risk of slipping

When the ground is wet or loose, use extreme caution to prevent the mower from slipping. Use extreme caution when moving downhill. On cut plant material, no matter if wet or dry, the risk of slipping is high.

Mowing surfaces with fire hazard

- Carry a sufficient amount of suitable extinguishing agent.
- If side inclination is too great, fuel may leak from the carburetor or the tank. This poses a fire hazard!
- Observe the mowed surface also after moving is completed to ensure that no fire will start.

To avoid risk of fire, keep the following components free of dirt, grass, hay, leaking oil, grease, etc:

- Engine
- Silencer (manifold, guard, clearances)
- Battery
- Area around the fuel tank

Caution when using accessories

Be careful when pulling loads:

- Only use tow-bars authorized by “AS-Motor Germany”.
- Observe the maximum load carrying capacity (Technical data).
- Observe the safety instructions in the operating instructions of the tow-bar.

- Only transport loads that you can handle safely.
- Only drive on slopes up to 10°.
- Do not take tight corners.
- Be extremely cautious when moving in reverse.

When work is completed

After each mowing, close both fuel valves.

Prior to leaving the device, wait until the engine comes to a standstill and remove the ignition key.

After switching it off, let the device cool down for at least 20 minutes before you store it in a dry, closed, sufficiently ventilated room.

Never store the device when there is fuel in the tank inside a building where fuel vapours might come into contact with open fire or sparks.

Hydraulic components

The device contains hydraulic components.

In case of improper repair or damage to the hydraulic components, pressurised hydraulic fluid may leak. The fluid may enter the skin and thus cause severe injuries.

- Only carry out maintenance work as described in these operating instructions.
- If hydraulic fluid has entered your skin, contact a doctor immediately.

Use caution during maintenance and repair

Only carry out maintenance work as described in these operating instructions. Have an authorised service centre carry out all other work.

Only use the knives and spare parts authorized by “AS-Motor Germany”. Unauthorized knives and spare parts can cause severe injuries.

Prior to all maintenance work, wait until the engine comes to a standstill and pull off the spark plug connector.

We explicitly point out that, in accordance with the Product Liability Act, we are not liable for damages that were caused by our devices if

- worn or damaged parts were not repaired or replaced on time.
- these damages were caused by improper repair.
- when changing a part, our original parts or parts authorised by use were not used.
- the repair work was not carried out by an authorised service station.

The same applies for spare parts and accessories.

Device description

Figure shows AS 915 ENDURO

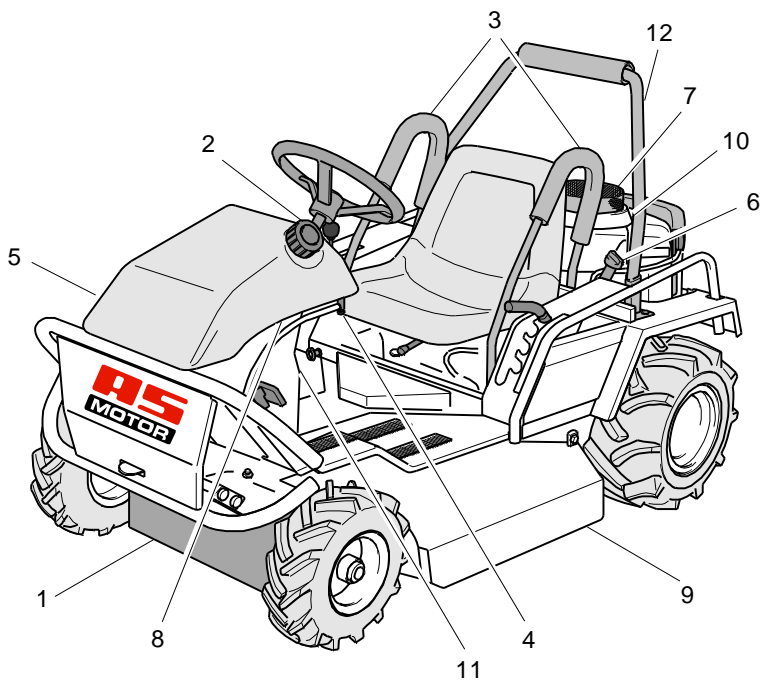

- 1 Impact protection front
- 2 Tank cap
- 3 Lateral supports
- 4 Fuel valve 1
- 5 Fuel valve 2
- 6 Engine oil filler neck
- 7 Ventilation grid
- 8 Fuses circuit protection
- 9 Side plates impact protection/cover
- 10 Engine
- 11 Type plate
- 12 Support pipe (only AS 915)

Control elements

Front area

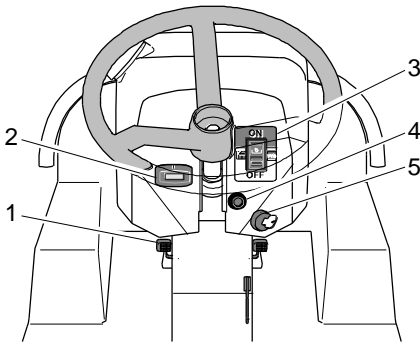

Differential lock (1)

With the left foot pedal, actuate the differential lock.



Pedal is actuated:

Differential lock is on

Pedal is not actuated:

Differential lock is off

Operating hours counter (2)

The operating hours are counted as soon as the engine is running. The display remains visible also when the engine is standing still.

Observe the information in chapter Maintenance.

Blade clutch switch (3)

The blade clutch switch is a protective device. If you declutch the blade the blade comes to a standstill within 5 seconds



Clutching blade:

Press the lock at the bottom part of the rocker switch upwards and press the rocker switch upward (ON).

Declutching blade:

Press the switch down (OFF).

Ignition lock (5)

The ignition lock has three positions.

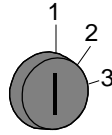

- 1: Ignition off.
The key can be removed.
- 2: Ignition on.
Control lamp (4) illuminates.
- 3: Electro starter on.

Brake

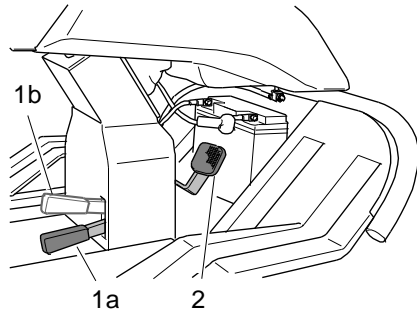

Foot brake

Braking:

Release the drive lever and press the right foot pedal (2) down.

Parking brake

Releasing the parking brake:

Press the right foot pedal down, press the locking lever (1a) down.

Putting on the parking brake

Press down the right foot pedal and pull the locking lever all the way up (1b). Then the foot pedal remains in down position.

Control lever at seat

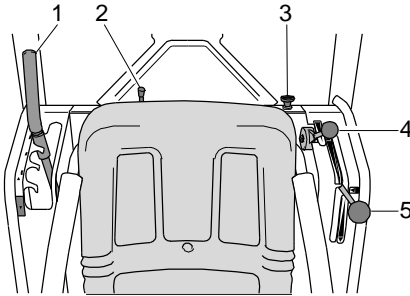

Cutting height adjustment (1)



The cutting height of the lawn can be set to four positions.

Position "Stop" is the transport position.

Sitting position

Press the lever (2) to the left and move the seat to the desired position.

Lever for choke (3)

The choke is only closed when the cold engine is started. As soon as the engine is running, open the choke.



Closing the choke:
Pull out the lever for the choke (3) by pulling it forward.



Opening choke:
Push back the lever for the choke (3).

Accelerator (4)

Via the accelerator, you change the engine speed.



Highest speed (full throttle):

Press the accelerator all the way down.

Lowest speed (idling speed):

Pull the accelerator all the way up.

Drive lever (5)

The drive lever is required for moving the mower forward, reversing as well as stopping the mower. The further you move the lever in one or the other direction, the faster the device moves.

The drive lever automatically goes to neutral position when it is released from the position "Driving in reverse". This prevents accidental reversing.



Moving forward



Stopping (neutral position)



Reversing

Drive/idle mode

To push the mower without engine drive, unlock the drive below the driver seat and release the parking brake. Subsequently, the mower can only be braked via the foot brake.

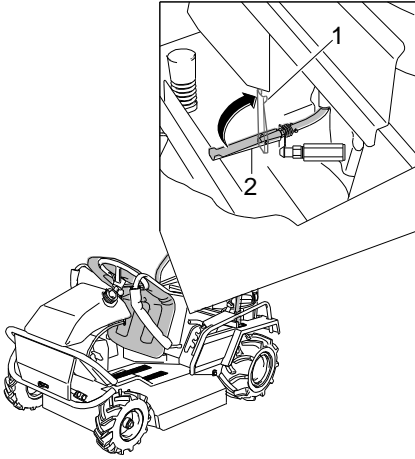

1: Locked

2: Unlocked (idling)

Fuel valve

At the bottom of the tank, at the left rear and at the right front, there is one fuel valve each.

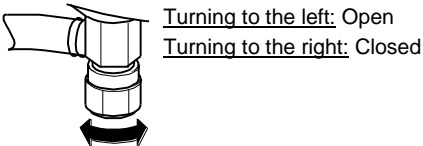
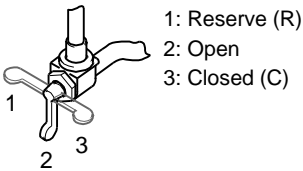

Transport

Transport the device on a freight vehicle or a trailer which is designed for a carrying capacity of at least as great as the empty weight of the device.

Transport on pallets

For transport over short distances, use a fork lift or a lift truck.

For longer distances, load the device with a fork lift onto a freight vehicle or trailer.

The user must be authorised to operate a fork lift. When the machine is lifted, all persons must step away from the working area of the fork lift.

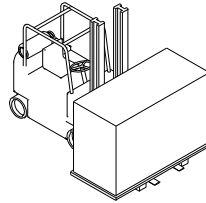

Notice! Drive the fork lift completely under the longitudinal beams of the wooden pallets.

Transport of ready-to-use device



Warning!

Risk of injury due to the heavy weight of the device. The device can fall over and fall down and cause severe injuries.

Observe the following notices.

Prior to transport, let the device cool down for at least 20 minutes. Close the fuel valves.

Loading

Use suitable ramps for loading that

- can carry the empty weight of the device + 100 kg.
- are wider than the device.
- have a slip-free surface.

- Put the device in front of the ramps and make sure that the ramps
 - are as wide as the wheel gauge of the device.
 - are tightly secured to the platform.
 - are not steeper than 15°.
- Carefully drive the device via the ramps onto the platform.
- Secure the device against rolling, sliding, tilting, and fuel leakage.

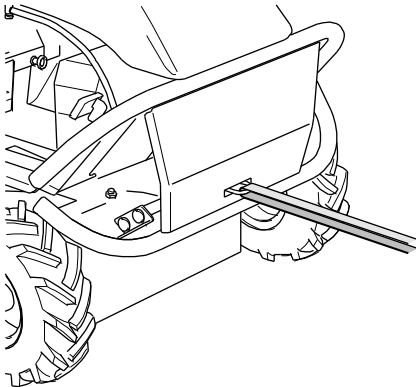
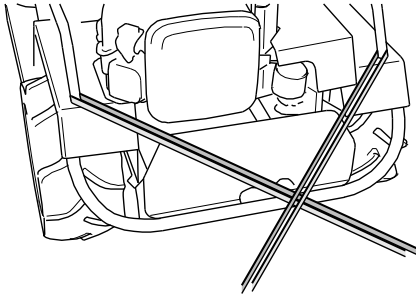

- Secure the device with belts to the frame elements that can hold the weight.

Caution! To prevent damages to the device, we recommend to fasten the straps exactly as shown in the illustration. Do not overtighten the straps.

Unloading the device

- Undo the transport fastenings.
- Drive the device carefully down the ramps of the platform.

Assembly

Scope of delivery

The device is shipped in a carton on a pallet.
The scope of delivery included:

- The device.
- This operating manual.
- Warranty card.
- Steering wheel with feather key.
- 2 side supports.
- 2 protective coverings for side supports.
- Support pipe (only AS 915).
- Protective covering for support pipe (only AS 915).
- Ignition key.
- Screws, nuts and discs for the assembly of the steering wheel, support pie and side supports.
- See operating instructions of the engine manufacturer

Unpacking

- Remove the carton, the frame and the film.
- Check the air pressure of all tires (see Technical data).

Mounting

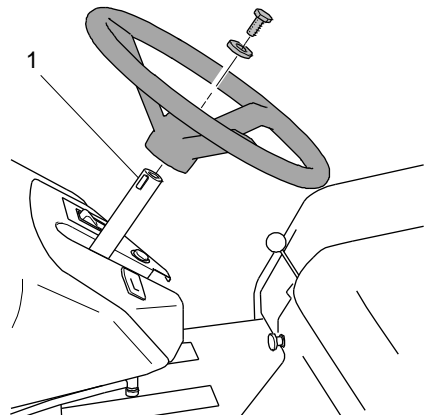

1. Mount the assembly wheel. (observe the feather key (1)).

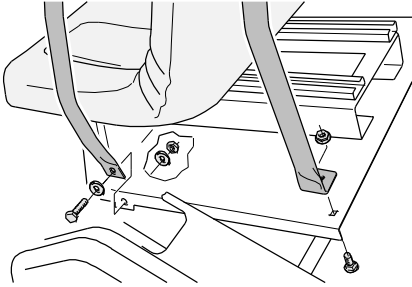

2. Slide the protective coverings over the side supports and close the Velcro closures of the protective coverings.
3. Screw both side supports to the device.

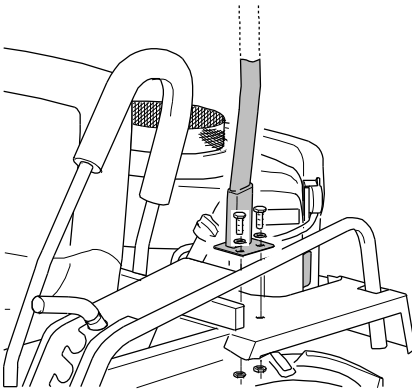

4. Applies only to AS 915: Slide the protective covering over the support pipe and close the Velcro closure of the protective covering.
5. Applies only to AS 915: Screw the support pipe to the device.
6. Remove the two metal transport securing devices (one metal hook each is screwed to the front and the rear).
7. Release the parking break, unlock the drive and push the mower off the pallet.
8. Relock the drive.

Connecting the battery



Caution!

When the battery is connected, there is a risk of short circuit.

Do not put tools or metal objects onto the battery. Observe the assembly order when connecting and disconnecting the battery.

1. Connect the red cable (+) to the battery.
2. Connect the black cable (-) to the battery.

Information on mowing

Prior to mowing, check your device for completeness, proper functioning, and cleanliness. A dirty ventilation grid causes overheating of the engine, this can damage the engine. A dirty protective grid at the silencer poses a fire hazard.

Frequent engagement and disengagement of the clutch increases wear of the blade drive belt and the blade brake. Especially in case of high grass, clutch engagement leads to overload.

To keep the area well maintained, mow frequently and keep the grass short.

Only mow with a sharp and undamaged blade. Have the blade sharpened and balanced regularly (by authorised service centre).

Do not mow when the grass is wet or when it is raining. The turf may be damaged and there is a danger of slipping!

Turn the device around only in already mown sections. Do not leave the device unattended while the engine is running

Set the cutting height so that the blade does not touch the ground even in case of terrain unevenness.

Always set the blade to transport position when you do not mow.

For mowing, always turn the accelerator lever to full throttle to achieve the best mowing performance.

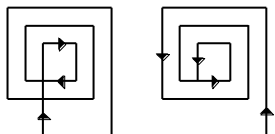

To avoid blockage during the ejection of grass, we recommend, for flat terrain, to proceed according to the mowing patterns. Mulch is shredded into much smaller pieces when you mow the terrain once again in the opposite direction.

Prior to starting

Checking the oil level

Caution! Before mowing, always check the engine oil level and the oil level in the hydrostat (see Maintenance).

Fuel

As fuel, use unleaded petrol (see operating instructions of the engine manufacturer).

You can use E10 petrol. Do not store E10 petrol longer than 30 days.

Tanking up



Danger!

Fuel is ignited by hot engine parts. Prior to filling up, switch off the engine and wait for at least 20 minutes until the engine has cooled down. Observe the safety instructions regarding the fuel!

Filling in the fuel:

1. For filling, use a canister with a filler spout or use as funnel.
2. Open the canister carefully so that the existing overpressure is discharged slowly and no fuel spurts out.
3. Open the tank cap carefully so that the existing overpressure is discharged slowly and no fuel spurts out.
4. Fill the fuel tank.
5. Screw the tank cap on tightly.

Adjusting the seating position

Adjust the seat in the longitudinal direction until your feet are positioned on the inclined support plates and you sit comfortably.

Starting



Danger!

During startup, there is a risk of injury caused by the rotating blade.

Make sure that no one is within the danger zone of the blade.

Safety switches

The device is equipped with safety switches. To start the engine, the following requirements must be met:

- A driver sits in the driver seat.
- The blade clutch is switched off.
- The drive lever is in neutral position.

If the engine is running and the driver leaves the seat, the engine is shut off.

If the engine was shut down due to a safety switch, turn the ignition key to position "Ignition off". By this, you will avoid discharging the battery.

Starting the engine

Start the device only when it is positioned on even and firm terrain.

1. Open both fuel valves.
2. Sit down on the driver seat.
3. Switch off the blade clutch.
4. Move the drive lever to neutral position.
5. Only for cold start: Move out the lever for the choke.
6. Move the accelerator lever to middle position.
7. Turn the ignition key to start position.
8. After the engine starts, release the ignition key and press the lever for the choke back in.

9. For mowing, set the accelerator lever to max. speed.

If the engine does not start after 5 seconds, release the key and wait for approx.

15 seconds before trying to start the device again.

Engaging the blade

Only engage the blade when it turns freely and does not come into contact with objects or the floor.

Do not engage the blade in uncut grass because the blade drive otherwise becomes overloaded, can be damaged, or can wear prematurely.

1. Start the engine.
2. Move the lever for the cutting height adjustment to the highest cutting position.
3. Release the Foot brake.
4. Switch on the blade clutch switch - the blade starts up.
5. Set the desired cutting height.

If you set the cutting height to transport position during mowing, the blade is automatically disengaged.

Reengaging

1. Switch off blade clutch switch.
2. Move the lever for the cutting height adjustment to the highest cutting position.
3. Release the Foot brake.
4. Switch on the blade clutch switch - the blade starts up.
5. Set the desired cutting height.

Disengaging the blade when running over paths:

1. Switch off blade clutch switch.

Oil pressure switch



Danger!

If the engine shuts down while you are mowing, the device can roll away.

Immediately actuate the parking brake to prevent the device from rolling away.

The oil pressure switch ensures that the engine is not damaged when the device is used in steep terrain.

The oil pressure switch switches off the engine when damage to the engine may occur due to lack of oil pressure. This may occur when:

- Oil level is too low.
- The device is in too steep a sloping position while in steep terrain.

How steep the gradient for the oil pressure switch to switch off the engine may be depends on the engine type, direction of inclination, and the oil level.

In order to restart the engine, let the device roll to terrain that is less steep while in idle state. In every case, check the oil level.

Towing



Danger!

The device can roll away without the drive.

Never unlock the drive in steep terrain without securing the device against rolling away.

If the engine cannot be started again, the device must be towed.

1. While using the brakes, let the device roll to terrain that is less steep.
2. Secure the device against rolling away or sliding.
3. Secure the device with a cable winch that has got enough load capacity.
4. For towing unlock the drive and release the parking brake.

Driving



Danger!

Mowing on a slope is dangerous. There is a risk of tilting and slipping. Observe the safety instruction for mowing on slopes.

In case of a hazardous situation, switch off the drive and declutch the blade.

Braking



Warning!

The brake does not work if you continue to hold the drive lever while braking.

Release the drive lever when you actuate the foot brake.

To stop, move the drive lever slowly to neutral position or step on the foot brake.

The foot brake acts on the rear wheels. When the foot brake is actuated, the drive moves to direction "STOP" (neutral position). When the foot brake is pressed quickly and fully, the drive lever swivels all the way to neutral position.

Use the actuation via foot pedal only in exceptional circumstances because the mower stops abruptly.

Driving

1. Start the engine.
2. Release the parking brake.
3. Slowly move the drive lever to the desired driving direction. The further the lever is moved away from the neutral position, the faster the mower moves.
4. To stop, move the drive lever slowly to neutral position or step on the foot brake.

When you actuate the foot brake and switch on the drive, you can hear an alarm tone.

Reversing



Danger!

Danger of injury when reversing. Make sure that your path is clear of obstacles and that no other persons stand behind your device.

Always reverse slowly. Be especially cautious when the blade is engaged.

1. Release the parking brake.
2. Slowly move the drive lever to the rear. The more you move the lever away from the neutral position, the faster the mower moves.
3. In order to stop, move the drive lever slowly to neutral position.

The drive lever automatically goes to neutral position when it is released from the position "Driving in reverse". This prevents accidental reversing.

Differential lock

The differential lock connects the two rear wheels rigidly to each other. This improves traction. Actuate the differential lock when a wheel slips.

Always actuate the differential lock when moving downhill. This improves the driving stability of the device. The risk of sliding or swerving of the rear is reduced and safe braking is possible.

Driving in curves while the differential lock is actuated is only possible with limitations.

To avoid excessive wear,

- actuate the differential lock only when the device is stopped, if possible.
- always step on the pedal all the way.
- release the differential lock when it is no longer absolutely needed.

Switching off and parking



Warning!

Risk of injury in case of unauthorised use.

Always remove the ignition key when you do not use the device.

1. Move the drive lever slowly to neutral position.
2. Turn the accelerator lever to idle speed.
3. Switch off the blade clutch.
4. Move the lever for the cutting height adjustment to transport position.
5. Actuate the parking brake.
6. Turn the ignition key to "ignition off".
7. Wait until the engine comes to a standstill before you step away from the device.
8. Remove the ignition key.
9. Close both fuel valves.

Maintenance and cleaning

Regular maintenance keeps your device ready for use.

If you do not observe the maintenance notices, faults may occur that are not covered by the

warranty. Operational safety is endangered as well.

Contact your authorised service centre for checkup if you detect problems during maintenance.

Component	Action	Maintenance interval	
		A	B
Device	Check for safe working condition (basic inspection).	■	▲
	Clean.	■	
	Customer service.		▲
Fuel	Check fuel level.	■	
	Is the tank cap closed?	■	
Tank, fuel valve, and fuel line	Check parts for leaks and check for good condition.	■	▲
Ventilation grid	Clean.	■	▲
Engine cooling	Clean.		▲
Spark plug	Check/replace.		▲
Air filter	Maintain.	■	■▲
Blade and fastening components	Check for wear and damage. See chapter Checking the blade.	■	▲
	Change.		▲
	Clean the screw-on point of the knife blade.	■	
Blade brake	Does the blade function safely and does the blade come to a standstill within 5 seconds?	□	▲
Drive lever	Does the device stop when the lever is in neutral position (STOP)?	□	▲
	Does the lever move to neutral position when the foot brake is actuated?	□	▲
	Does the lever move to neutral position when it was released from position "Driving in reverse"?	□	▲

V-belt	Are the belts tensioned correctly, without fissures, and in good condition?		▲
Bowden cables	Check for proper function and ease of movement.	■	▲
Acceleration lever	Check for proper function.	□	▲
Chassis and impact protection	Check for rust and fissures and check the welding seams.	■	▲
	Are all protective devices and covers in place, fastened correctly and properly functioning?	■	▲
Label	Condition of the labels.	■	▲
Engine	See operating instructions of the engine manufacturer.	■	▲
	Check oil level (see operating instructions of the engine manufacturer).	■	▲
	Oil change.		▲
	Oil filter change		▲
Parking brake	Check.	■	▲
Check the foot brake	Check the foot brake	□	▲
Flammable material	Remove easily flammable debris buildup from the engine and the device.	■	▲
Steering	Check the clearance.	■	▲
Tyres	Check tyres and, if necessary, the tyre pressure.	■	▲
Safety switches	Check the switches at the driver seat, cutting height adjustment, and drive for proper function.	■	▲
Ignition lock	Check for proper function.	□	▲
Hydrostatic transmission	Check oil level.	■	▲
	Repair leaks.		▲
	Oil change after 50 h and every 200 h thereafter.		▲
Differential gear	Perform oil change.		▲
	Check for oil contamination.	■	▲
Battery	Check the charging conditions.		▲
Lubrication	See chapter grease lubrication	■	▲■

- A Before and after each use.
- B Annually or every 50 h.
- By the user when the engine is not running.
- By the user when the engine is running.
- ▲ By the authorised service centre.

Preparations

Prior to all maintenance and cleaning work:

1. Let the device cool down for at least 20 minutes.
2. Close the fuel valve and the tank ventilation.
3. Disconnect the minus pole of the battery.

Caution! During repair and maintenance work, lift the device only by the frame.

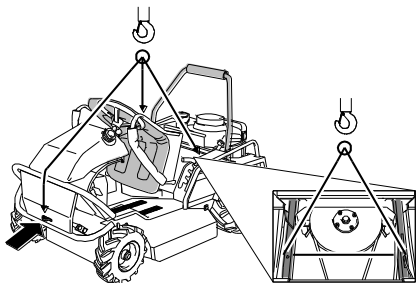

You can use the points marked with arrows, located at the front of the towing eye and at the frame below the seat, as mount points.

Cleaning the device

Depending on use, clean the device thoroughly, especially the bottom and the knife.

Grass cuttings and dirt that are stuck interfere with the grass ejection and impair the cutting quality. To sufficiently cool the engine, keep the engine cover, ventilation grid and engine clean.

Fire hazard! Take particular care that the components at the silencer are clean.

For cleaning, use a hand brush. Remove stubborn dirt with a wooden or plastic spatula. Clean the outside housing parts with a cloth.

Do not clean the device with water spray or high-pressure cleaner! Do not use any aggressive cleaning agents.

General inspection

To make sure that the device can be operated safely, check all nuts, bolts, screws, connection of fuel lines, air filters etc. regularly for firm seating. Check the ignition wire and the spark plug connectors for damage.

Immediately replace damaged or worn parts, especially covers, silencers or fuel tank (authorized service centre).

Check all parts that contain fluids for leaks and proper condition. These can be: Fuel tank, fuel valve, fuel lines, carburetor, engine, gears, battery, hydraulic system.

In case of leaks, contact an authorised service centre.

Check the safety switches for proper function. It must not be possible to start the engine when:

- there is no driver on the driver's seat.
- The blade clutch is switched on.
- The drive lever is not in neutral position.

If the engine is running and the driver leaves the seat, the engine must shut down.

Contact an authorised service centre if one of these conditions is not met.

Operating hours counter

When you press the button at the operating hour counter, the display will alternate between:

- Operating hours
- Hours before the next engine oil change (OIL)

- Hours before the next grease lubrication of the device (LUBE).

The intervals in the maintenance table and in the operating instructions of the engine manufacturer apply.

The specifications for the next engine oil change and the next grease lubrication at the operating hour counter serve only as additional reminder.

If the display flashes showing the text "OIL" or "LUBE", check the information in the maintenance table regarding oil change or lubrication.

Checking the parking brake



Danger!

If the parking brake is incorrectly adjusted, the device can roll away. Make sure that the parking brake is always functioning properly.

1. Put the device on a non-slip surface (e.g. concrete or asphalt).
2. Unlock the drive.
3. Actuate the parking brake.
4. Try to move the device.

If the rear wheels lock, the parking brake is correctly adjusted. If you can move the device, the parking brake must be re-adjusted by an authorised service centre.

Checking the foot brake

Check if the drive lever return to STOP when the brake pedal is actuated.

Grease lubrication

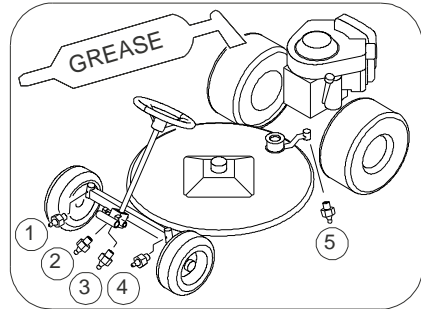

On the lubrication chart, the position of the grease nipples are marked.

1. Clean the grease nipples.
2. Lubricate the grease nipples with a hand grease gun (1-2 strokes).
3. Remove any excess grease that has squeezed out from the bearing points.

Checking the blade



Danger!

Improperly mounted and maintained blades pose a severe injury hazard.

Work at the blade shall only be performed by an authorised service centre.



Wear sturdy gloves when you check the blades.

Work on the blade requires special qualifications because an unbalance test is required and the torques must be observed.

Check the blade and all fastening parts for wear, damage and cracks

- before and after each mowing operation.
- when there are significant changes.

All blade parts shown and their fastening parts must be changed

- when damage or cracks were found.

- At least once a year or every 50 operating hours, regardless of whether there is wear or not. Material wears out, gets cracks which can endanger persons or property.

Vibrations indicate that

- the blade is worn excessively on one side or
- damage of motor or cutting unit mount (e.g. rubber elements).

Improperly sharpened blades increase the device load and result in fatigue cracks and breakage.

Ejected pieces can cause severe injuries.

Cutting blades

If the cutting blades strike a foreign object, they can be twisted (overload protection).

Never mow when the cutting blades are twisted.

Turn the cutting blades back to their initial position. If the cutting blades cannot be turned back, have the cutting mechanism checked for damage and the cutting blades turned back or replaced by an authorised service centre.

To prevent unbalance replace or reverse the cutting blades (2) in pairs only!

Cutting blades AS 900

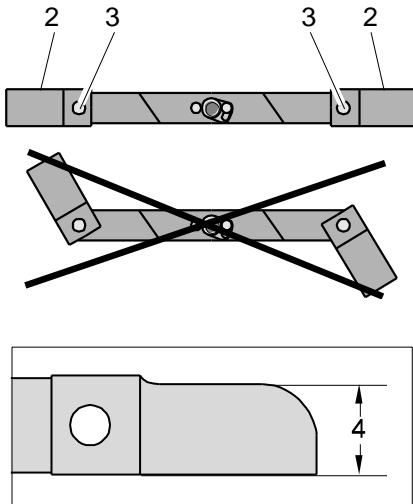

The cutting blades (2) are reversible blades. Reverse both blades

- when the width (4) of a cutting blade is smaller than 55 mm and
- when the other side of the cutting blade has not yet been used.

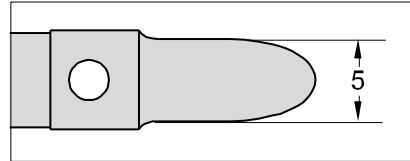

The cutting blades and fastening parts must be changed

- when the width (5) of a cutting blade is smaller than 40 mm and the other side of the cutting blade has already been used.
- when the thickness of the cutting blade at any point is below 1 mm (except cutting edge).

Cutting blades AS 915

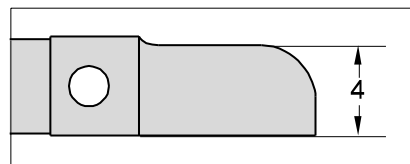
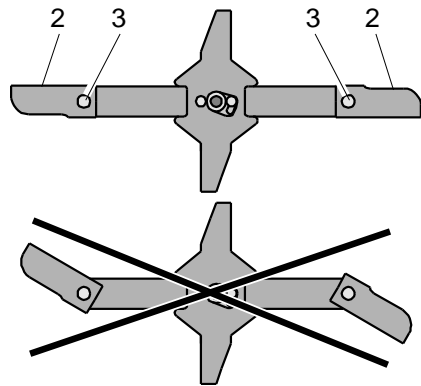

The cutting blades (2) and the fastening parts must be changed

- when the width of the cutting blade (4) is under 50 mm.
- when the thickness of the cutting blade at any point is below 1 mm (except cutting edge).

Original blade

An original AS-blade is engraved with:

AS GXXXXXXXXX or EXXXXX

This corresponds to the spare part number.

Checking the condition of the cutting blade screws



Danger!

When a screw head is worn, the cutting blades can become loose.

Check all screws used for fastening the cutting blades!

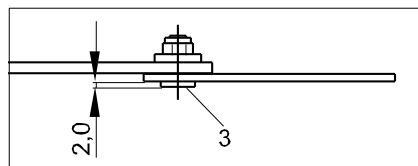

The screw head (3) wears off during mowing and must be replaced at the latest when it is down to a thickness of 2 mm.

To prevent unbalance replace the cutting blade screws in pairs only!

Checking the blade clutch

Check the blade clutch for proper function by disengaging the blade. The blade must come from full speed to a standstill in less than 5 seconds. Contact an authorised service centre if this is not the case.

Maintaining the engine



Danger!

If the speed of rotation is set too high, objects can be ejected. The engine can be damaged and noise pollution increases.

Do not change the basic setting of the carburetor or the speed control.

The operating instructions of the engine are prepared by the engine manufacturer. They contain the maintenance instructions and the warranty conditions for the engine. If warranty work for the engine is required, please contact your authorised service centre or the nearest authorised engine dealer.

To ensure a long service life of the engine, sufficient engine cooling is required.

Keep the

- engine cover (ventilation grid),
 - silencer (protective grid) and
 - cooling fins of the engine
- clean at all times.

Checking the engine oil level

Never allow the oil level to be too low otherwise the engine can be damaged. Never fill in too much oil. Otherwise, there is the risk that the oil enters and destroys the air filter.

For this, observe the attached operating instructions of the engine.

Checking the spark plug



Danger!

The ignition system generates an electromagnetic field.

Wearers of pacemakers must not work on live parts.

Soiled spark plugs reduce the engine output. Clean the electrode of the spark plug with a brass wire brush. Check the electrode gap (see operating instructions of the engine manufacturer). Make sure that the insulator around

the electrode is not damaged. Never use a damaged spark plug.

Tighten the spark plug using the correct torque (see operating instructions of the engine manufacturer).

Always check both spark plugs.

Maintaining the air filter



Danger!

Cleaning agents pose a fire and explosion hazard.

Never clean the air filter with flammable solvents.

Make sure that the air filter is always clean. A dirty air filter reduces the engine performance and leads to increased engine wear and fuel consumption. Irrespective of the operating hours, change the filter insert at least once a year. Do not operate the engine without air filter.

For this, observe the attached operating instructions of the engine.

Checking and charging the battery



Danger!

When the battery is being charged, explosive gases escape.

Never charge the battery close to flames. Avoid sparking and do not smoke.



Caution!

When the battery is connected, there is a risk of short circuit.

Do not put tools or metal objects onto the battery. Observe the assembly order when connecting and disconnecting the battery.

If the starter does not turn the engine or turns it too weakly charge the battery.

The battery is maintenance-free and gas-tight. For charging the battery, you require a special

charging system. Battery chargers for car batteries are not suitable!

The charging current must not exceed the maximum of 3 ampere, otherwise, the battery heats up too much!

Use electronically controlled charging systems. These charging systems detect the connected battery and charge it with the required charging current and terminate the charging process when the battery is full.

Charge the battery before you put the device away for winter storage. A fully charged battery lasts for approx. 4 months before it needs to be recharged.

Caution! Never confuse the plus and minus terminals.

1. Pull the tank out off the holders and put it to the right.
2. Disconnect the black cable (-).
3. Disconnect the red cable (+).
4. Dismantle the battery from the device.
5. Charge the battery.
6. Mount the battery into the device.
7. Connect the red cable (+).
8. Connect the black cable (-).
9. Remount the tank.

Hydrostat transmission

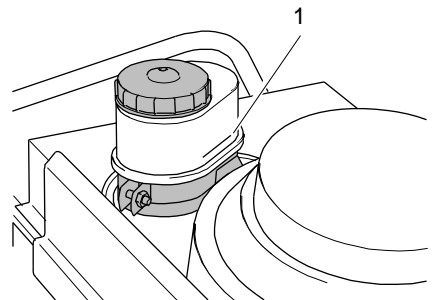

After a standstill of several hours on an even surface, the oil level must have reached the marking (1) of the oil container. If this is not the case, top up the oil (see Technical data).

Only fill in oil until the oil level has reached the marking of the oil container.

Storage

Storing the device

Keep the device in a closed, dry, and well ventilated room and out of reach of children. Always eliminate all problems of the device before you store it so that the device is always in a safe-to-operate state. Let the engine cool down before you store the device in closed rooms.

Also observe the notices on storage in the attached operating instructions by the engine manufacturer.

Longer storage

1. Observe the safety instructions regarding the handling of fuel.
2. Draining fuel tank: Put a piece of a tube on the fuel valve and fill the fuel in an adequate fuel container.
3. Emptying carburetor: Start the engine and let it run until it stops on its own.
4. Clean the device thoroughly.
5. Touch up defects in painting (for spray paint, see Accessories).
6. Preserve the engine:
 - Unscrew the two spark plugs.
 - Fill a tablespoon of engine oil into each spark plug opening.
 - Briefly actuate the starter (oil is distributed in the cylinder).
 - Screw the spark plugs back in.
 - Do not put the spark plug connector on!
7. Remove the ignition key and keep it separate from the device.

In autumn, have your device checked by an authorised service centre!

Also observe the notices on storage in the attached operating instructions by the engine manufacturer.

Restarting

If you want to start the device after a longer storage, carry out the tasks described in chapter Maintenance.

Spare parts

The reliable and safe operation of the device also depends on the quality of the spare parts used. Only use original spare parts and accessories that were approved by "AS-Motor Germany". When foreign parts are installed, the warranty and guarantee shall be void for the foreign part and for the device and for any resulting damage.

Inform your authorised service centre about the device type and serial number of your devices when you order spare parts.

Wear parts

Some parts are wear parts. They wear during use and must be replaced. The warranty does not cover the following parts:

Blades, cutting blades, cutter bars, blade bolts, sliding plates, V-belt, chains, Bowden cables, starter ropes, pressure plates, air filters, spark plugs, disc springs, lock washers, fuses, discs, thrust plates, pressure discs, protection skirts, impact protection, wheels, tires.

Disposal

The device cuts and shreds the plant material in a single operation. Shredded plant material decomposes quickly, can be utilized as fertilizer, and, therefore, be left on the ground.

Dispose of waste oil and fuel in accordance with the local regulations or return it to an oil shop.

Packaging, device, and accessories are made of recyclable materials and must be disposed of accordingly.

Warranty

The conditions of the warranty can be found on the reverse side of your warranty card. Send the filled-out warranty card immediately after the purchase of your device to “AS-Motor Germany” or the supplier. Otherwise, the warranty is no longer valid.

Preserve the proof of purchase or the warranty card that was filled out by the vendor.

Troubleshooting

The following table contains the most frequent problems and their elimination. If more problems occur, contact the closest authorised service centre.

You can find an authorised service centre on our home page www.as-motor.de.

Problem	Possible cause	Remedy
Starter does not turn	Safety switches are not actuated.	<ul style="list-style-type: none"> – Move drive lever to neutral position. – Switch off blade clutch switch. – Move cutting height adjustment to transport position. – Put driver in seat to activate seat contact switches.
	Battery is empty: – Ignition key was not in position "Off". – Standstill period was too long.	Charge the battery (see Checking the battery) or have authorised service centre do so.
	Fuse is defective.	Replace (if necessary, have authorised service centre do so).
	Battery is defective.	Replace the battery (authorised service centre).
Engine does not start	Fuel valves are closed.	Open fuel valves.
	No fuel is in the tank.	Refill fuel.
	Choke is open.	Close the choke.
	Device was tilted – oil leaked into the air filter.	Replace air filter, unscrew spark plug and start several times when the fuel valve is closed, dry the spark plug and screw it back in.
	Engine was flooded due to too many start attempts.	Unscrew spark plugs and start several times when the fuel valve is closed, dry the spark plugs and screw them back in.
	Spark plug connector is pulled off.	Observe the safety instructions! Put spark plug connector back on.
	Air filter is dirty.	Maintain air filter (see also Maintenance and cleaning).

	Spark plugs are sooted, damaged, or incorrect electrode gap.	Clean spark plugs and check electrode gap (see also Maintenance and cleaning). Replace spark plugs if necessary.
	Housing of the mower is jammed.	See also Maintenance and cleaning.
	No oil pressure: Too little engine oil.	Check engine oil level, refill.
	No oil pressure: Slope too steep.	Bring the device into a level position.
	Poor quality, dirty, or old fuel.	Clean fuel system (authorised service centre). Always use fresh fuel.
Engine starts badly or runs irregularly	Choke is closed.	Open the choke.
	Air filter is dirty.	Maintain air filter (see also Maintenance and cleaning).
	Poor quality, dirty, or old fuel.	Always use fresh fuel.
	Spark plug is sooted, damaged, or incorrect electrode gap.	Clean spark plug and check electrode gap (see also Maintenance and cleaning). Replace spark plug if necessary.
Device does not move	The drive is unlocked.	Lock the drive.
	Hydrostatic drive is overheated.	Cool down (see also Maintenance and cleaning).
The blade does not rotate	Lever for cutting height adjustment in transport position.	Lower lever for cutting height adjustment to the desired cutting height.
	Electromagnetic clutch has insufficient voltage.	Let engine run for some time at medium speed or charge battery.
	V-belt is insufficiently tensioned or damaged.	Authorised service centre.
Strong vibrations during operation	Unbalance at the blade caused by incorrect sharpening or chips on the blade.	Have blade resharpened and balanced by an authorised service centre. Replace a damaged blade immediately.
	Blade drive shaft is bent due to collisions with foreign objects.	Authorised service centre.
	Engine fastening is loose.	Authorised service centre.
	Blade fastening is loose.	Authorised service centre.
Irregular noises	Loose fastening elements.	Authorised service centre.

	Silencer is defective.	Authorised service centre.
Engine is smoking	Air filter is soiled or drenched with oil.	Maintain or replace air filter (see also Maintenance and cleaning).
	Oil level is too high.	Have authorised service centre lower the oil level to the marking.
Engine gets hot	Ventilation grid is dirty.	Clean ventilation grid.
	Oil level in the engine is too low.	Refill engine oil (see operating instructions of the engine manufacturer).
	Cooling fins of the engine are dirty.	Have cooling fins cleaned by authorised service centre.
Uneven cut, lawn becomes unsightly	Blade is dull or worn.	Have blade resharpened and balanced by an authorised service centre. Replace a damaged blade immediately.
	Speed is too high proportionately to the cutting height.	Reduce speed and/or select the correct cutting height.
	Housing of the mower is heavily contaminated.	Clean.
	Different tire pressure.	the tire pressure.
	Mower housing is not parallel to the ground.	Adjust (authorised service centre).
Mulching result with high plant material not satisfactory	Speed is too high.	Reduce speed.
Mulching result with low plant material not satisfactory	Plant material is ejected too quickly.	Increase speed.
Housing is jammed	Mowed grass was too long or too damp.	Adjust cutting height and mowing speed to the mowing conditions.
	Blade is worn.	Authorised service centre.
	Engine speed is too low despite full power.	Authorised service centre.
The device does not stop when the brake is actuated	Brake is adjusted incorrectly, worn, or defective.	Authorised service centre.
The engine does not switch off	Switching off system is defective.	Close the fuel valve. Authorised service centre.

The tires become flat	Thorns or sharp objects damage the tires.	If necessary, use tire protection gel (authorised service centre).
------------------------------	---	--

Technical data

Type	AS 900 ENDURO	AS 915 ENDURO
Range of application (temperature)	0 - 30 °C For temperatures below 5 °C, observe the engine manufacturer's information regarding the engine oil.	
Engine, type Manufacturer	Two cylinder four stroke engine Briggs & Stratton	
Type	Intek, 7 Series, V-Twin	Professional Series 7220
Cylinder capacity	656 cm ³	656 cm ³
Performance	11.1 kW (15.1 PS)	13.3 kW (18.0 PS)
Engine speed	3300 min-1	3300 min-1
Starting device	Electric start	
Battery	12 V, approx. 19 Ah	
Fuses		
Main fuse	15 A	
Generator	25 A	
Drive	Hydrostatic transmission with differential lock	
Speed forward	0 to 10 km/h	
Speed reverse	0 to 9,5 km/h	
Maximum area coverage	approx. 9000 m ² /h	
Turning radius	approx. 0.8 m	
Front axle	Pendulum mounted	
Seat	Moveable, spring-loaded	
Cutting device, type	Cutter bar with screwed on cutting blades	Cutting bar with screwed-on blades and wing blades
Cutting width	90 cm	90 cm
Cutting height	50 to 90 mm in 4 levels	50 to 90 mm in 4 levels
Drive of cutting tool	V-belt	V-belt
Clutch of cutting tool	Electromagnetic with brake up to approx. 120 cm	Electromagnetic with brake up to approx. 150 cm
Growth height		
Measures and weights		
Weight	298 kg	307 kg
Transport size with packaging L/W/H	186/107/101 cm	186/107/101 cm
Max. tyre dimensions L/W/H	183/100/95 cm	183/96/105 cm
max. towing load	100 kg	100 kg
max. vertical load	25 kg	25 kg

Capacities	
Fuel tank	15 litres (unleaded regular petrol)
Engine oil (see Checking the oil level)	approx. 1.9 litres SAE 30
Transmission oil	1.9 litres 80 W90
Oil in hydrostat	1 litres SAE 15W50 or 20W50
Sound level	
according to DIN EN 12733	
Measured sound level L_{WA}	98,0 dB
guaranteed sound level L_{WA}	100 dB
Sound level at working place L_{pA}	88 dB
Vibration emission value	
according to DIN EN 12733	
Hand-arm-vibrations $a_{h,W}$	3,8 m/s ²
Measurement uncertainty U	0,5 m/s ²
Whole body vibration $a_{h,W}$	0,9 m/s ²
Measurement uncertainty U	0,5 m/s ²
Tyre pressure	
Front	1 bar
Rear	1,5 bar

Accessories

Trailer:	G06800003	E09311
Trailer hitch:	G06800005	E09313
Snow remover blade without adaptor:	G06837006	E09306
Adaptor snow removal blade:	G06637009	E09309
Snow tires (set):	G06637006	E09316
Lawn tyres front (set):	G06621001	E09318
Lawn tyres rear (set):	G06621002	E09319
Spray paint 400 ml, colour orange:	G00011050	E04606
Seat suspension unit:	G06680124	E09348
Clinometer:	G06950027	E11835



AS-Motor Germany GmbH & Co. KG
Ellwanger Straße 15
D-74424 Bühlertann
www.as-motor.de

Declaration of conformity

We declare that the grassland mower type
with serial number
as well as type
with serial number

AS 900 ENDURO
starting from 021415010001
AS 915 ENDURO
starting from 018215010015

as brought into circulation by us conforms to all relevant safety and health requirements of the EC directives listed.

- 2006/42/EC,
- 2004/108/EC
- 97/68/EC

Function:

The device is exclusively intended for cutting grass or similar vegetation in agriculture, forestry, and landscape conservation.

Applied standards:

DIN EN 12733

Place where all technical records are filed:

AS-Motor Germany GmbH & Co. KG
Ellwanger Straße 15
D-74424 Bühlertann

Bühlertann, January 2015

Eberhard Lange
Managing director

By Proxy Frank Einsiedler
Head of development



Professional technology for gardens and landscapes

Allmäher®	Manoeuvrable meadow mower for extensive green area care. The Allmäher reliably shreds metre-high grass, undergrowth, and weeds.
Ride-on Allmäher®	Ease of use and high area coverage all combined in a compact ride-on mower. Low centre of gravity, optimum weight distribution, and broad wheel base provide you with the best performance on slopes and power reserves.
Rear discharge mower	Professional lawn mower with rear discharge. With wheel drive and infinite speed regulation for exceptional cutting and catching performance in any situation.
Rotary mower	The economic alternative to bar mower. Ideal for fodder production. The grass is not shredded and placed into a pile on the side.
Flail mower	The flail blades are supported movably and avoid rocks and other obstacles and chop the cuttings several times.
Side discharge mower	This solid allrounder has a side discharge, wheel drive, and a housing of 3 mm thick plastic-coated steel.
Mulching mower	Mulching saves both time and money. The mulch stays on the ground and practically disappears into the lawn so that no complex disposal is necessary.
WeedHex	Removes weeds carefully, quickly, and without the use of chemicals: on transport surfaces, walls, curbs, and between interlocking blocks.