



Witech Embedded Ltd.

<http://www.arm9board.net>

User's Mnaual
for
TE6410

TE6410 Users Manual

Part 1 - Introduction



Copyright@2010-2011

<http://www.arm9board.net/>



COPYRIGHT STATEMENT

Contents (content being images, text, programs and scripts) of this manual is copyright © Witech Systems Ltd. All rights expressly reserved.

Any content of the manual printed or downloaded may not be sold, licensed, transferred, copied or reproduced in whole or in part in any manner or in or on any media to any person without the prior written consent of Witech Systems Ltd. including but not limited to:

- transmission by any method
- storage in any medium, system or program
- display in any form
- performance
- hire, lease, rental or loan

Requests for permission to reproduce material from this manual should be addressed to Witech Systems Ltd.



TE6410 is an Embedded Computer (Single Board Computer) based on the 667MHz Samsung S3C6410 (ARM11) microcontroller. TE6410 embodies abundant of built-in resources and powerful video processing capacity, which make the TE6410 reliable for the development of higher-end products.

Together with the TE6410 we provide BSPs (Board Support Packages) for Embedded Linux, WindowsCE and Android including basic drivers for all the components on the board and illustrating programs, which we believe can help the users in understanding the ARM architecture and shortening their development circle.

Here are some dos and don'ts for using the TE6410:

1. After opening the TE6410 package, please check and make sure that the following components are all enclosed:
 - 1 × TE6410 board
 - 1 × serial port cable
 - 1 × USB cable
 - 1 × Ethernet cable
 - 1 × JTAG wiggler with JTAG cable
 - 1 × 5V power supply
 - 1 × DVD
2. After purchasing the TE6410, please do inform us with your purchase information, including your name, registered email address, purchase date, invoice number and board ID to validate your membership for downloading the latest data from our website.
3. When using the SBC for the first time, please do **read and follow the user manual** to prevent unnecessary troubles and damages.
4. Every time before powering on the SBC, please touch anyone of the metallic interface with your fingers to unload the Electrostatic. **Do not touch the chips with your fingers!**
5. **Before physically operating the SBC, please switch the power off. Hot plugging is not supported except on the USB and Ethernet interfaces.**
6. We provide for the TE6410 12 weeks' guarantee (in the precondition of non-artificial damage) and 24 weeks technical support. .

Editor: Witech Co. Ltd.

Tel: 86-871-5899845

Fax: 86-871-5899845

Email: info@arm9board.net

Website: <http://www.arm9board.net/>



1. Brief Introduction

Along with the development of micro electronics, the ARM11 architecture is becoming more and more popular in higher-end products and embedded applications.

The Witech TE6410 SBC (Single Board Computer) is based on the Samsung ARM11 microcontroller S3C6410 (667MHz), which embodies abundant of built-in resources and powerful video processing capacity and supports mobileDDR and various models of Nand Flash. Which, together with the integrated useful interfaces such as VGA, TV, CAMERA, USB, SD, LCD, Ethernet, RS485, industrial CAN Bus and etc, makes the TE6410 SBC a powerful device for developing and implementing kinds of industrial products.

The TE6410 SBC is split into two parts, a core board and a carrier board. The core board is actually the central controlling module of the SBC, which embodies the S3C6410 CPU, mobileDDR RAM, NAND Flash and Nor Flash. Measuring only 50 x 60mm, the core board can be connected to the 130 x 130mm carrier board via four 80pin anti-oxidation connectors; once programmed, it can be also detached from the carrier board and used as individual COM (Computer On Module) and inserted like a "big chip" into test beds, prototypes, and production units for OEM deployment. The TE6410 SBC is designed in conformity with CE standard with full consideration to high speed signal competence, EM compatibility, and static protection and etc, to ensure stable performance under various environments.

Together with the TE6410 we provide BSP (Board Support Packages) for Windows CE6.0 and Embedded Linux-2.6, which provide drivers for all the bottom interfaces and devices and utility applications.

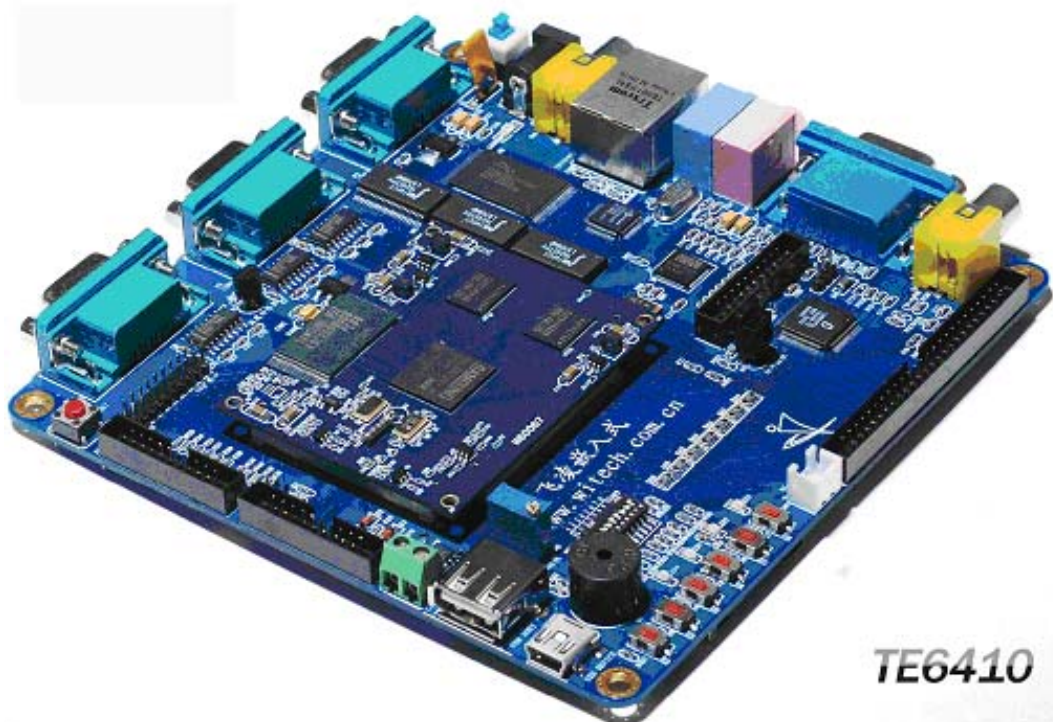



2. Hardware Features

- **Core Board** — 6 layer PCB, stable performance tested through electromagnetism
 - Samsung S3C6410 microcontroller based on the ARM1176JZF-S core, main frequency @ 533/667MHz;
 - 128MB DDRram;
 - 256MB NAND Flash;
 - 12MHz、48MHz、27MHz、32.768KH clock source;
 - 5V power supply adaptable
- **Carrier Board** — 4 layer PCB, stable performance tested through electromagnetism
 - One reset button implemented with specific reset chip;
 - 8-bit toggle switch for selecting boot mode;
 - One 2MB NOR Flash;
 - Three serial ports: 2 5-wire RS232 and 1 3-wire RS232;
 - One RS485 Bus;
 - **One CAN2.0 Bus;**
 - One 100M Ethernet port with DM9000AE and indicators;
 - One USB Host interface supporting USB1.1 protocol;
 - One USB Device interface supporting USB2.0 protocol;
 - One high-speed SD card slot supporting SD Memory and SDIO;
 - One WIFI expansion interface;
 - Stereo audio I/O sockets;
 - LCD and touch screen interface supporting 3.5", 4.3", 5.6", 5.7", 7", 8" TFT LCD and 10" LVDS LCD;
 - **One VGA interface with CH7026 supporting 800 x 600 resolution;**
 - Two TV output interfaces;
 - One CMOS camera connector supporting ITU-R BT601/656 8-bit mode;
 - Built-in RTC (Real Time Clock) with back-up battery;
 - One JTAG interface using 2*10pin connector;
 - One temperature sensor;
 - One Infrared receiver;
 - Six user buttons;
 - Four user LEDs;
 - One Buzzer;
 - One 2*10pin expansion interface containing 1 x GND, 1 x DA, 8 x AD, 10 x IO, 1 x SPI multiplexed with the IOs.



3. Boot Modes

The S3C6410 microcontroller supports booting from either NAND Flash, Nor Flash or SD card, we can set the boot mode by setting 8-bit toggle switch SW2.

Pins	Pin 8	Pin 7	Pin 6	Pin 5	Pin 4	Pin 3	Pin 2	Pin 1
Layout	SELNAND	OM4	OM3	OM2	OM1	GPN15	GPN14	GPN13
NAND Flash	1*	0	0	1	1	X	X	X
NOR Flash	X	0	1	0	1	X	X	X
SD card	X	1	1	1	1	0	0	0

* 1) “1” indicates “ON” while “0” refers to “OFF”, “X” indicates high/low power level;

2) Default boot device on the TE6410 has been set as NAND Flash.

The schematic of the boot mode selector is shown as below:

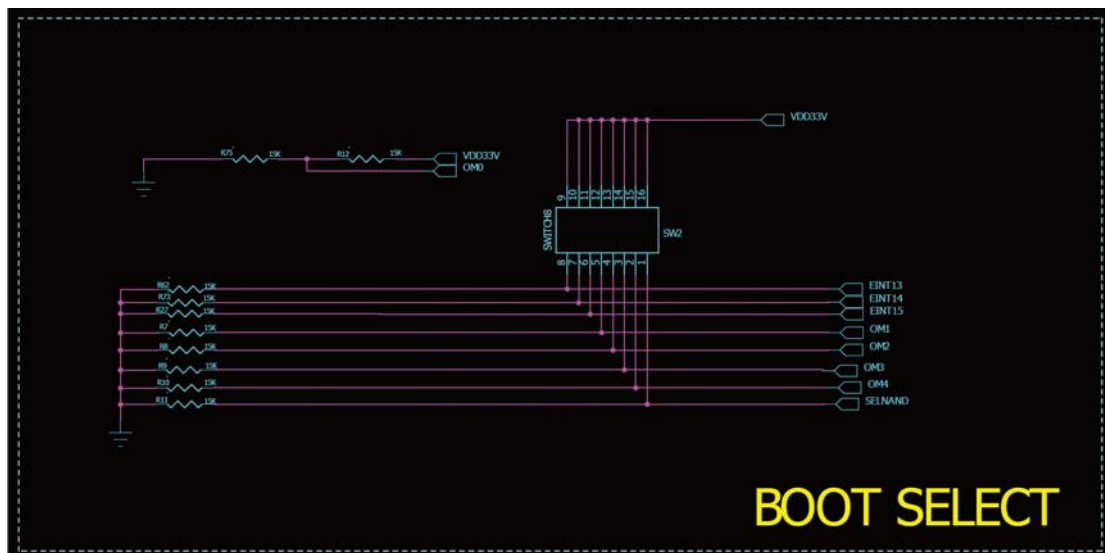

The OM0 is a signal that selects the clock source. When the OM0 is set as “0”, XTlpll is selected as the clock source; while when the OM0 is set as “1”, EXTCLK is selected. On the TE6410 SBC we selected XTlpll.

The signal SELNAND determines the type of NAND memory. It should be “1” (high power level) when using NAND Flash while “0” (low) when using ONENAND. On the TE6410 we use NAND Flash, therefore the power level of the SELNAND signal is high.

EINT13, EINT14 and EINT15 are pins that set the boot device for IROM boot mode. When booting in IROM mode, the S3C6410 microcontroller first runs the in-chip ROM firmware, read the statues of EINT15, EINT14 and EINT13, then, according to the statues of the pins, select the boot device. OM1-OM4 are the pins that sets the boot mode of the S3C6410.

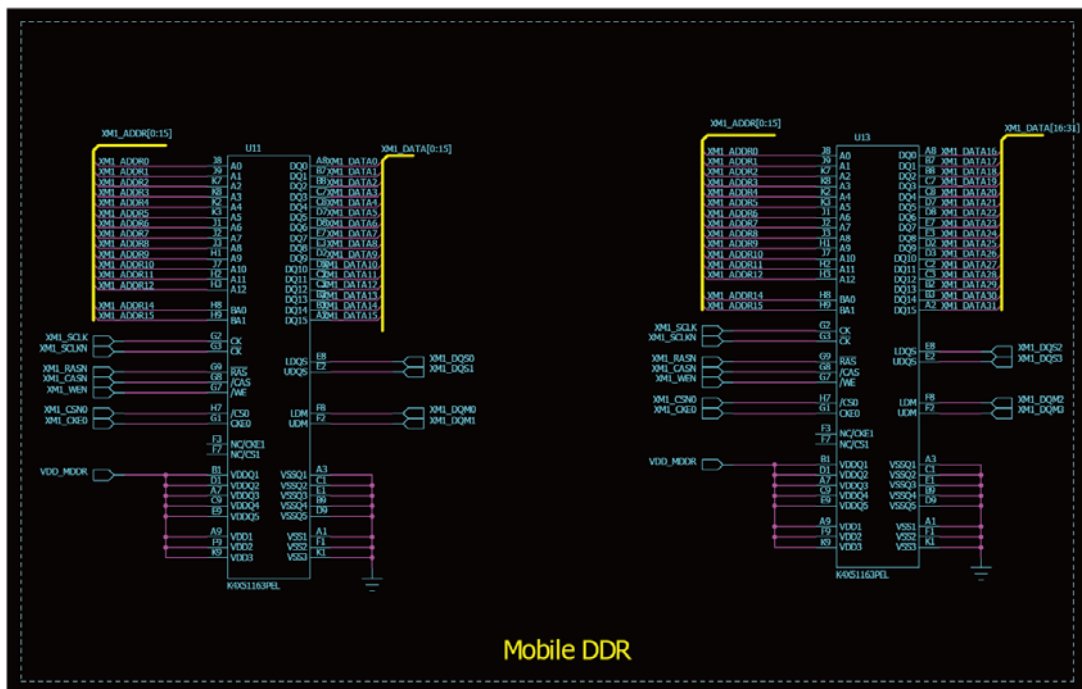

4.3 NOR Flash

The AMD 4MB NOR Flash chip AM29LV160D has been implemented on the TE6410. The S3C6410 microcontroller supports up to 27 address lines, among which the A20 – A26 are multiplexed with the DDR data bus D20 – D26. Since a 32bit DDRAM has been integrated on the TE6410, there are only 19 address lines (A1 – A19) and only 1M Bytes address space are available for the NOR Flash. All data signals, address signals, and controlling signals go through the 74LVC16245 bus buffers (three in total) to increase the driving capacity and thus ensure the system stability.

The schematic of the NOR Flash is as shown below:

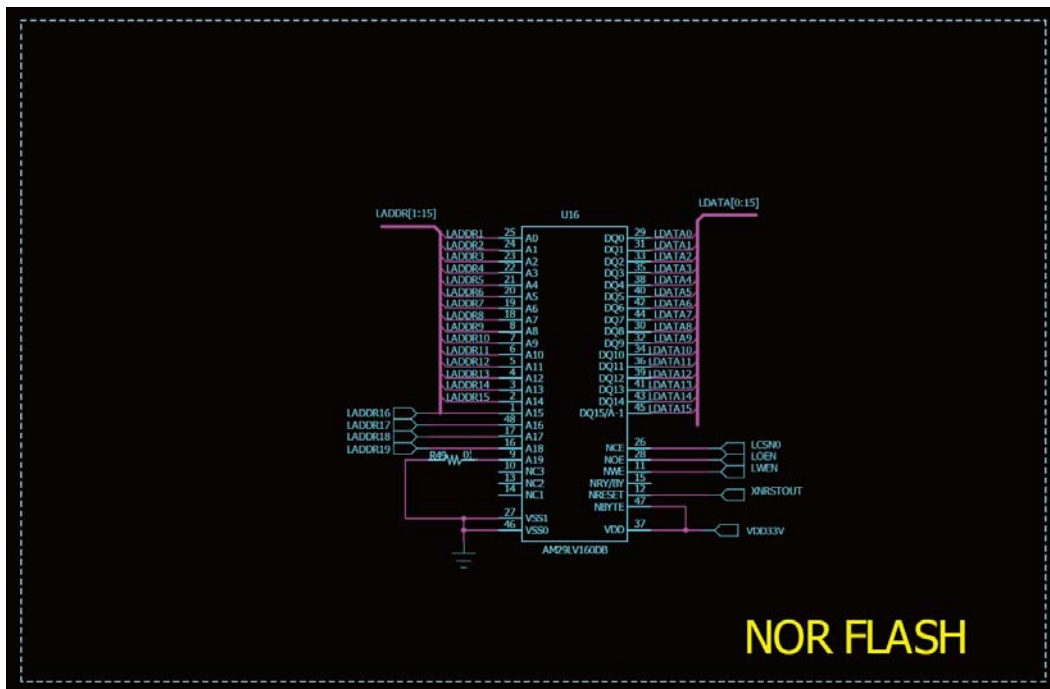

4.4 UART Interfaces

There are totally four serial ports on the TE6410 SBC: two 5-wire RS232 (COM0 and COM1), one 3-wire RS232 (COM2) and one RS485 (CON1).

Three MAX232 chips are used to implement the three RS232 interfaces, and one MAX485 chip implements the RS485 output

The COM0 has been used as debug port by default, which can be connected to the PC to display debug information.

Schematics of the serial ports are shown as below:

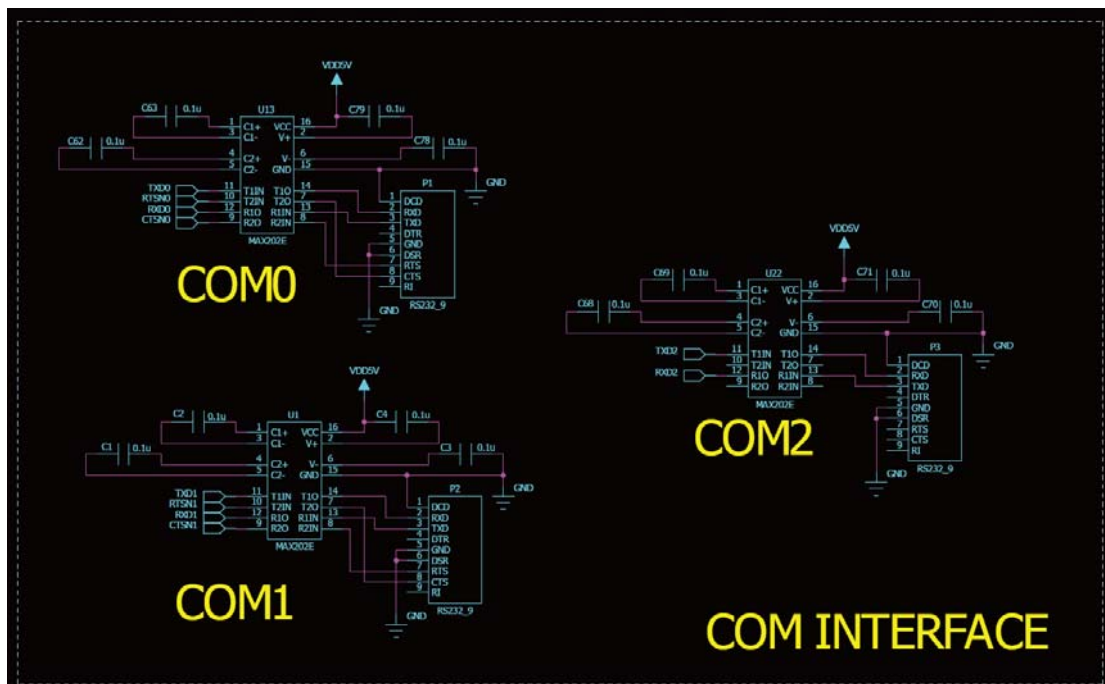

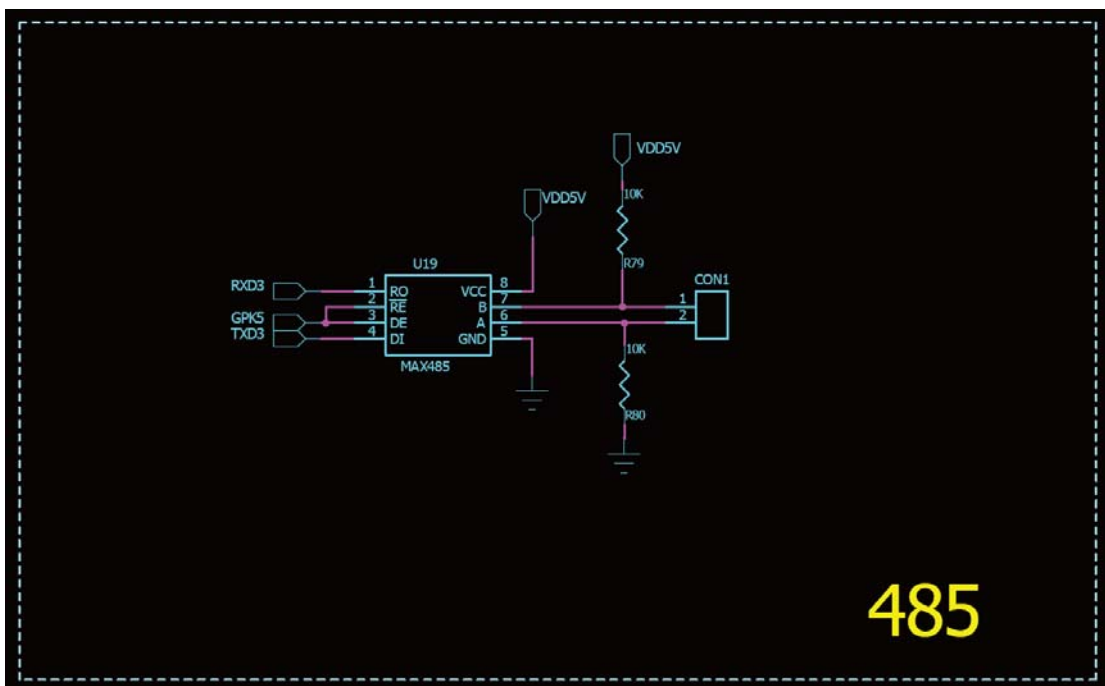

4.5 USB Host

The USB Host interface on the TE6410 supports USB1.1 protocol; it can be used to connect USB keyboard, USB hard disk, USB mouse, USB memory stick and etc.

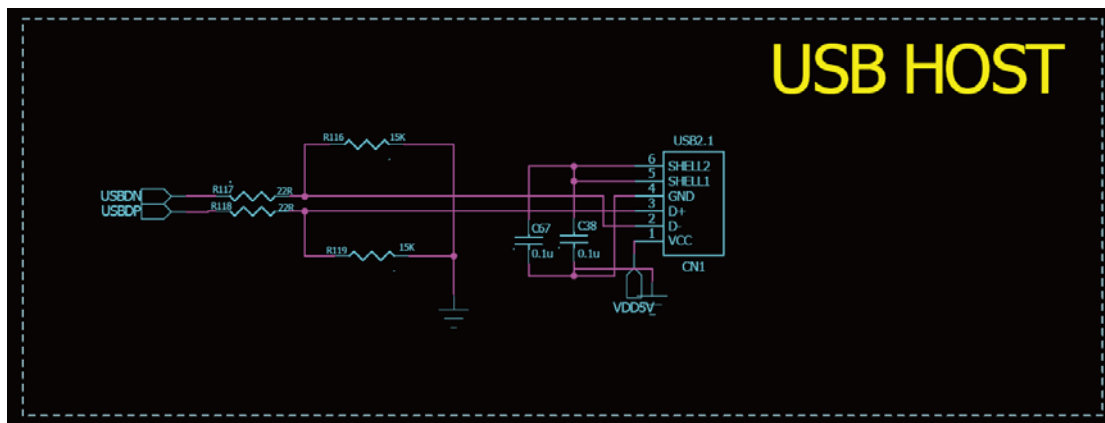

4.6 USB OTG

The USB OTG interface (Mini USB A/B port) supports USB 2.0 protocol with the maximum speed up to 480Mbps.

The USB OTG interface can be used for downloading programs and binaries.



USB OTG

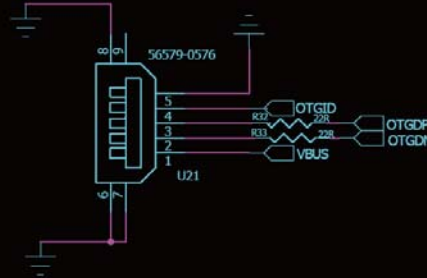

4.7 JTAG Interface

The JTAG interface on the TE6410 provides access to both the ARM11 core and S3C6410 in-chip peripherals, the DBGSEL signal determines which device to access:

When the power level of DBGSEL is high, the JTAG interface provides access to the S3C6410 in-chip peripherals; when the power level of DBGSEL is low, the JTAG interface provides access to the ARM11 core. The power level of DBGSEL can be set by the jumper J9.

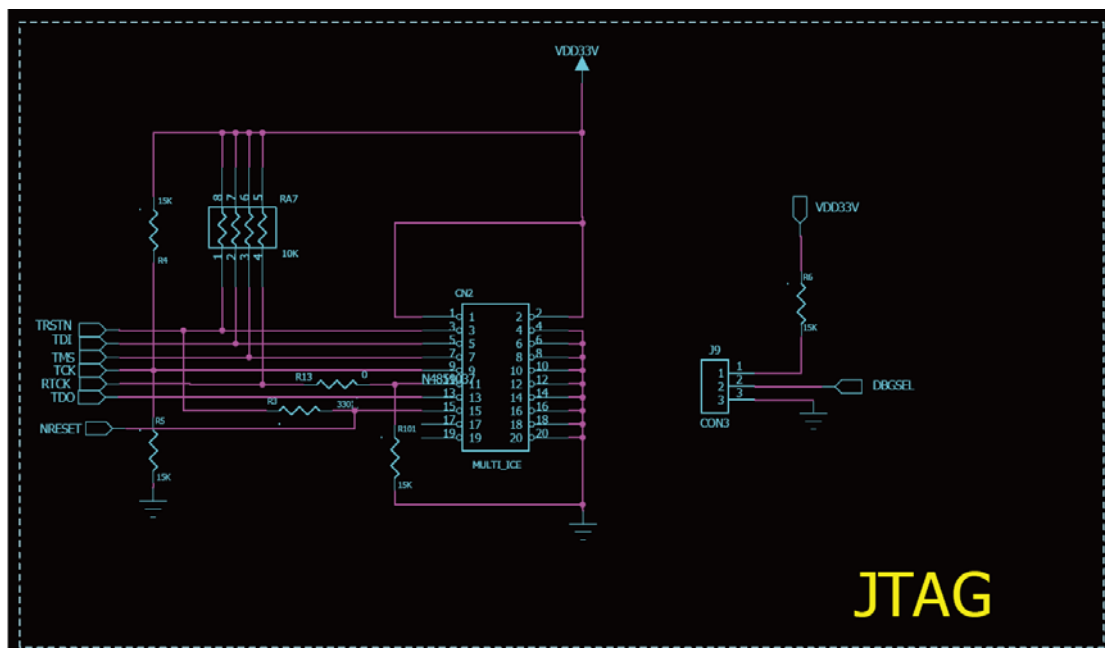

JTAG

4.8 RTC

The Real Time Clock on the TE6410 is powered by a button battery:

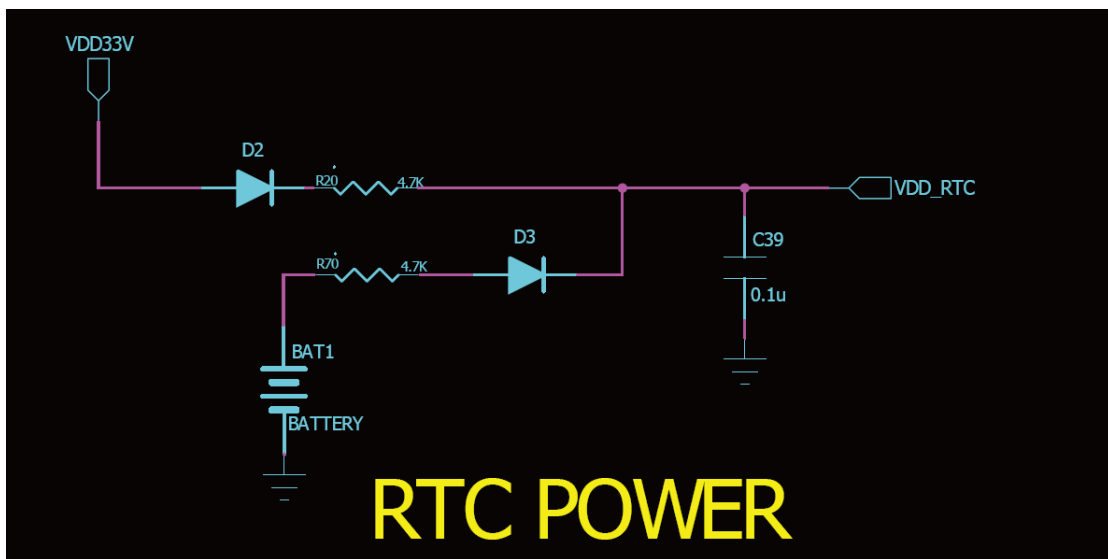

4.9 SD Card Slot

The 4-wire SD card slot supports both SD Memory 2.0 and SDIO 1.0 protocol. As SD memory interface it supports up to 8GB SD card; as SDIO, it can be used to connect WIFI module, GPS module, and etc.

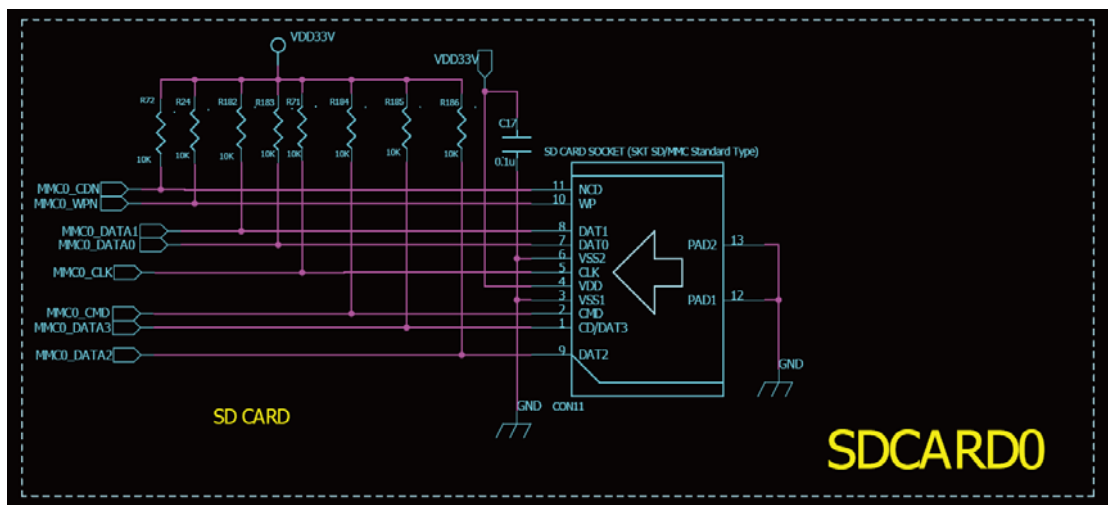

4.10 WIFI Connector

WIFI module and the SD CARD1 interface on the TE6410 use the same signal channel. Users can choose to use either WIFI or SD card.

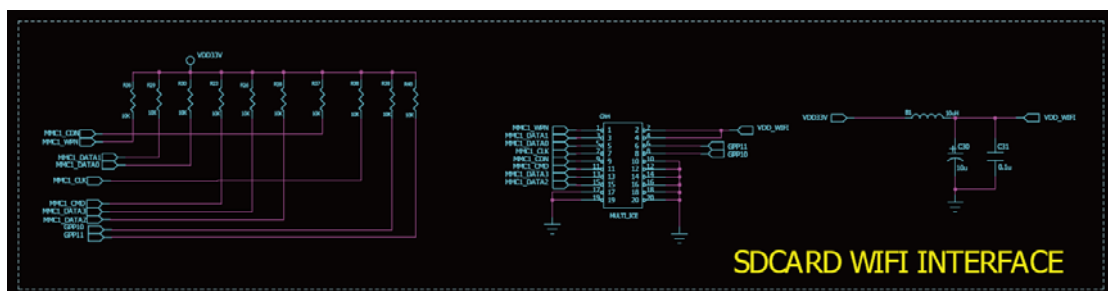

4.11 LCD and Touch Screen Interface



A 50pin 2.0mm pitch connector is used on the TE6410 as LCD interface, to which we can connect 3.5", 4.3", 5.6", 7", 8" TFT LCD. All data signals and controlling signals are connected to 22 Ω matched resistance to ensure the stability of the signals.

The schematic of the LCD interface is shown as below:

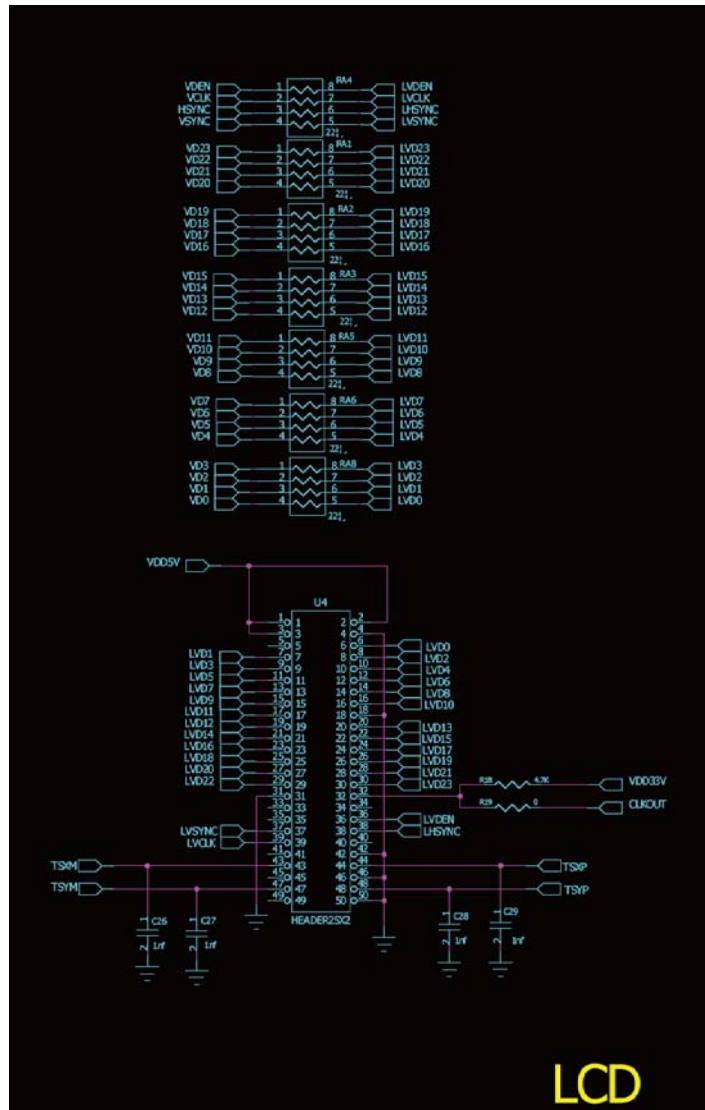

4.12 TV OUT Interface

The S3C6410 microcontroller supports TV OUT video output, on the TE6410 SBC it is implemented as a 2pin standard TV interface.

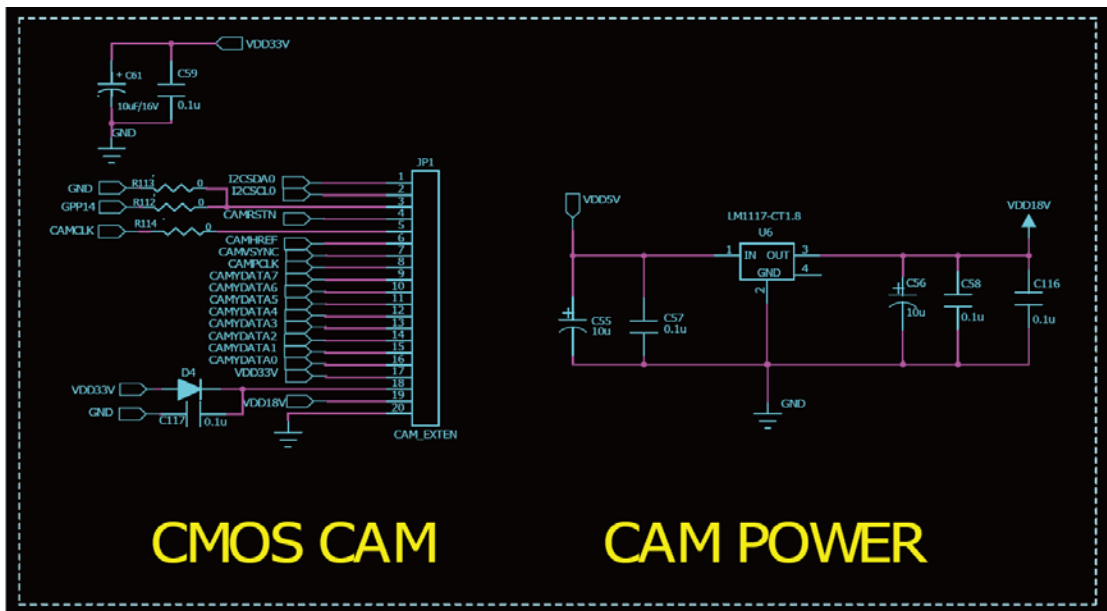

4.17 CAN Bus

The CAN Bus on the TE6410 is implemented by the MCP2515 chip, which supports CAN2.0 standard.

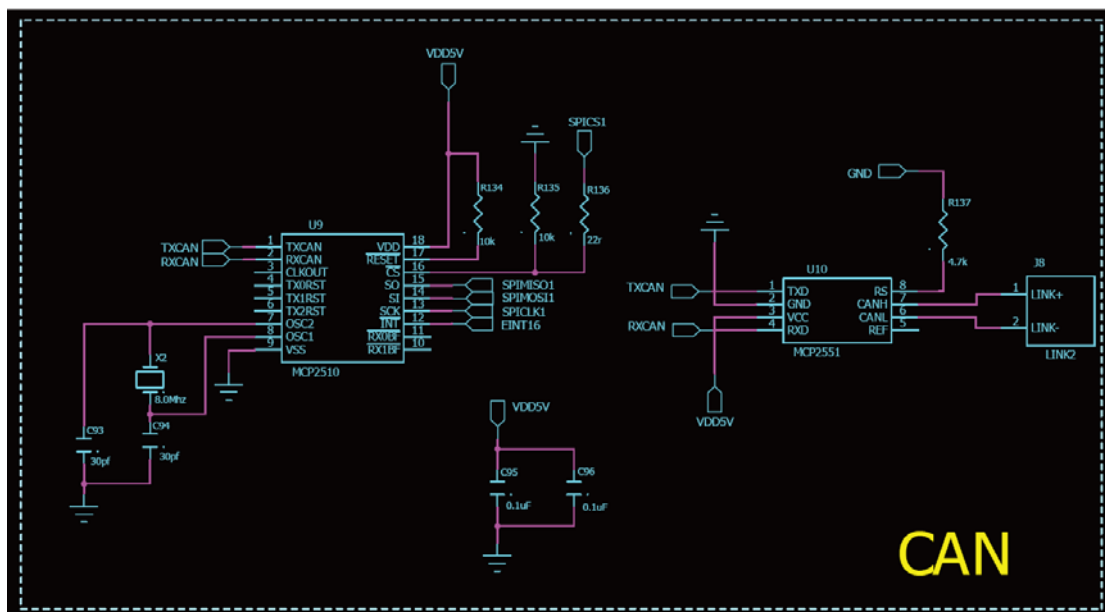

4.18 Reset System

The reset system on the TE6410 consists of a 6 x 6mm sensitive button and a MAX811t reset chip on the core board.

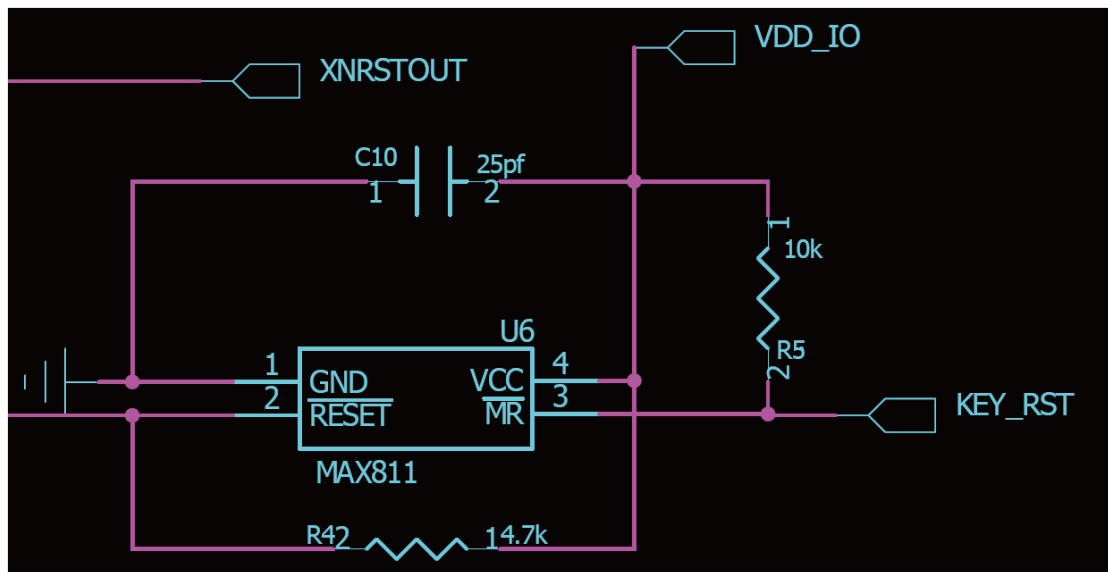
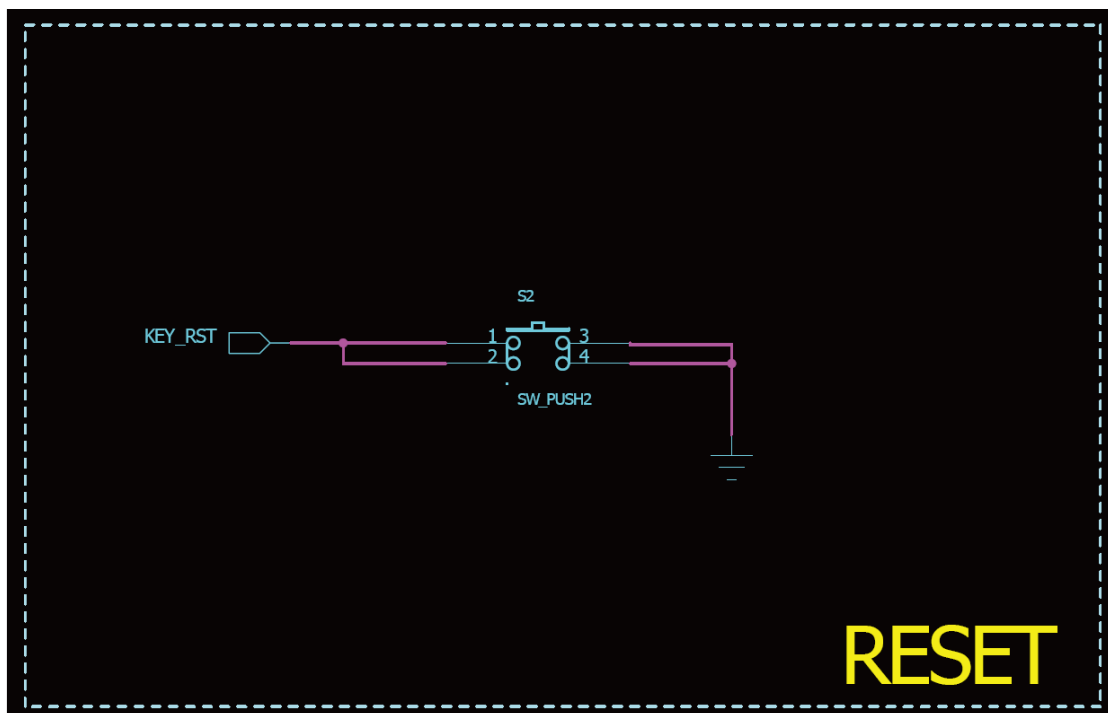

4.19 Temperature Sensor & IRDA

On the TE6410 there integrated a DS18B20 temperature sensor and a HS0038B infrared receiver:

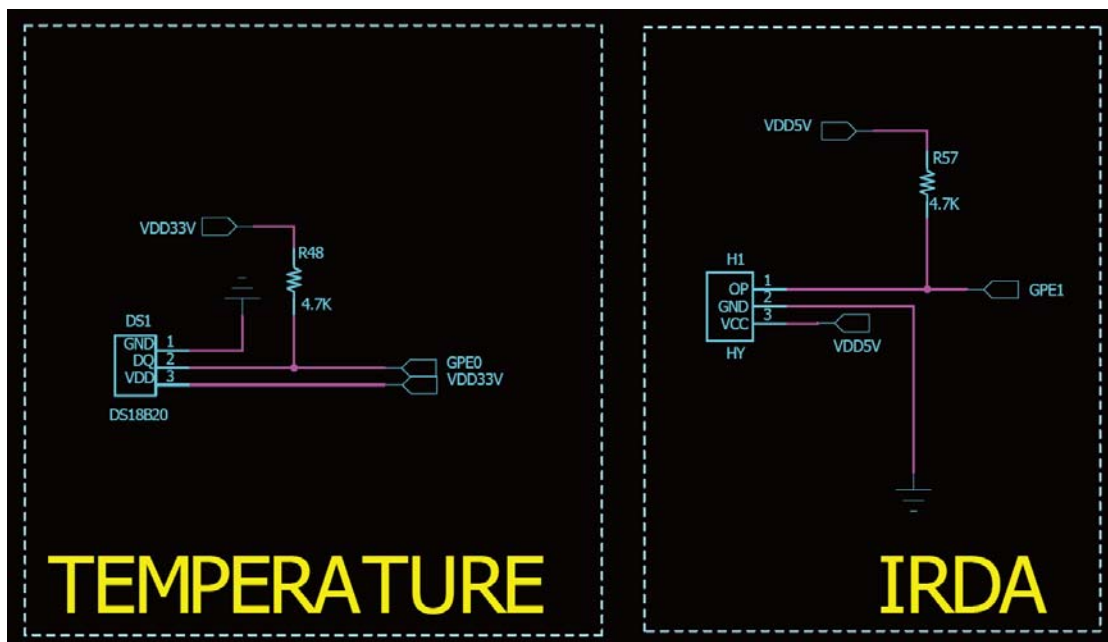

4.20 User IO

2 x 10pin IO pins are reserved on the TE6410 for the users, which includes 8 AD input, 1 DA output, 1 SPI, 1 GND and others as normal IOs.

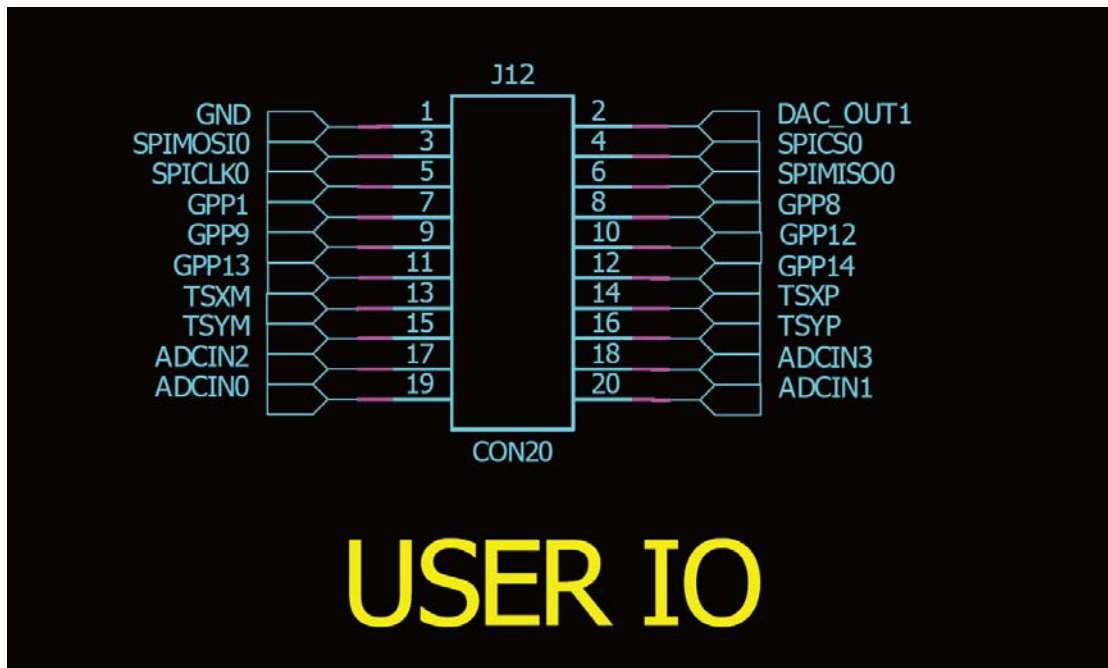



Witech Embedded Ltd.

<http://www.arm9board.net>

User's Mnaual
for
TE6410

Copyright reserved© Witech Co., Ltd.

Website: <http://www.arm9board.net> Email: info@arm9board.net Tel: +86-871-5899845



5. Core Board Layout

Unit: mm

