

MODEL: SC-11100
CONVECTION MICROWAVE OVEN

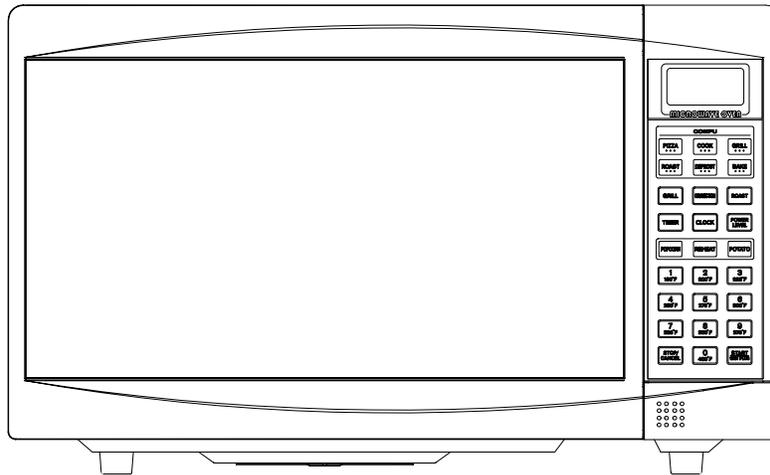

Microwave Oven Owner's Manual

PRECAUTIONS TO AVOID POSSIBLE EXPOSURE TO EXCESSIVE MICROWAVE ENERGY

Please read these instructions carefully before installing and operating the oven. Record in the space below the SERIAL NO. found on the nameplate on your oven and retain this information for future reference.

SERIAL NO.

1. Do not attempt to operate this oven with the door open since open door operation can result in harmful exposure to microwave energy. It is important not to defeat or tamper with the safety interlocks.
2. Do not place any object between the oven front face and the door or allow soil or cleaner residue to accumulate on sealing surfaces.
3. Do not operate the oven if it is damaged. It is particularly important that the oven door close properly and that there is no damage to the
 - a. Door (bent),
 - b. Hinges and latches (broken or loosened),
 - c. Door seals and sealing surfaces.
4. The oven should not be adjusted or repaired by anyone except properly qualified service personnel.

CONTENTS

PRECAUTIONS TO AVOID POSSIBLE EXPOSURE TO EXCESSIVE MICROWAVE ENERGY	0
SPECIFICATIONS-----	0
BEFORE YOU CALL FOR SERVICE-----	3
INSTALLATION -----	3
GROUNDING INSTRUCTIONS-----	3
RADIO INTERFERENCE-----	3
IMPORTANT SAFETY INSTRUCTIONS-----	3
MICROWAVE COOKING PRINCIPLES -----	3
UTENSILS GUIDE -----	3
PART NAMES -----	3
CONTROL PANEL -----	6
HOW TO SET THE OVEN CONTROLS -----	7
SETTING THE CLOCK-----	7
MICROWAVE COOKING -----	7
GRILL-----	7
CONVECTION-----	7
ROAST -----	8
SPECIAL FEATURES -----	8
POPCORN -----	8
REHEAT-----	8
POTATO-----	8
COMPU DEFROST -----	8
COMPU COOK-----	9
COMPU PIZZA -----	9
COMPU GRILL -----	9
COMPU ROAST -----	9
COMPU BAKE-----	10
CLEANING AND CARE -----	11

SPECIFICATIONS*

Power Consumption:	120V, 60Hz, 1450W (Microwave)
	120V, 1400W (Convection)
	120V, 1400W (top & bottom grill)
	120V, 1000W (top grill)
	120V, 400W (bottom grill)
Rated Microwave Output:	900W
Operation Frequency:	2450MHz
Outside Dimensions:	305mm(H)×525mm(W)×490mm(D)
Oven Cavity Dimensions:	219mm(H)×350mm(W)×355mm(D)
Oven Capacity:	28Litres
Cooking Uniformity:	Turntable System{Φ314mm}
Net Weight:	Approx. 22kg

*All data subject to verification by available data on the nameplate of the oven.

BEFORE YOU CALL FOR SERVICE

If the oven fails to operate:

1. Check to ensure that the oven is plugged in securely. If it is not, remove the plug from the outlet, wait 10 seconds, and plug it in again securely.
2. Check for a blown circuit fuse or a tripped main circuit breaker. If these seem to be operating properly, test the outlet with another appliance.
3. Check to ensure that the control panel is programmed correctly and the timer is set.

4. Check to ensure that the door is securely closed engaging the door safety lock system. Otherwise, the microwave will not operate.

IF NONE OF THE ABOVE RECTIFY THE SITUATION, THEN CONTACT A QUALIFIED TECHNICIAN. DO NOT TRY TO ADJUST OR REPAIR THE OVEN YOURSELF.

INSTALLATION

1. Make sure that all the packing materials are removed from the inside of the door.
2. **WARNING:** Check the oven for any damage, such as misaligned or bent door, damaged door seals and sealing surface, broken or loose door hinges and latches and dents inside the cavity or on the door. If there is any damage, do not operate the oven and contact qualified service personnel.
3. This microwave oven must be placed on a flat, stable surface to hold its weight and the heaviest food likely to be cooked in the oven.
4. Do not place the oven where heat, moisture, or high

humidity are generated, or near combustible materials.

5. For correct operation, the oven must have sufficient airflow. Allow 20cm of space above the oven, 10cm at back and 5cm at both sides. Do not cover or block any openings on the appliance. Do not remove feet.
6. Do not operate the oven without glass tray, roller support, and shaft in their proper positions.
7. Make sure that the power supply cord is undamaged and does not run under the oven or over any hot or sharp surface.
8. Do not use the oven outdoors.

GROUNDING INSTRUCTIONS

This appliance must be grounded. In the event of an electrical short circuit, grounding reduces risk of electric shock by providing an escape wire for the electric current.

WARNING Improper use of the grounding plug can result in a risk of electric shock.

ELECTRICAL REQUIREMENTS

The electrical requirements are a 120 volt 60 Hz, AC only, 20 amp. It is recommended that a separate circuit serving only the oven be provided. The oven is equipped with a 3-prong grounding plug. It must be plugged into a wall receptacle that is properly installed and grounded.

EXTENSION CORD

1. If it is necessary to use an extension cord, use only a 3-wire extension cord that has a 3-blade grounding plug and a 3-slot receptacle that will accept the plug on the microwave oven. The marked rating of the extension cord shall be equal to or greater than the electrical rating of the appliance, or

2. Do not use an extension cord. If the power supply cord is too short, have a qualified electrician or serviceman install an outlet near the appliance.

RADIO OR TV INTERFERENCE

Should there be any interference caused by the microwave oven to your radio or TV, check that the microwave oven is on a different circuit, [relocate](#) the radio or TV as far away from the oven as feasible or check position and signal of receiving antenna.

Notes:

If you have any questions about the grounding or electrical instructions, consult a qualified electrician or service person.

Neither [SYLVANIA](#) nor the dealer can accept any liability for damage to the oven or personal injury resulting from failure to observe the electrical connection procedures.

RADIO INTERFERENCE

Operation of the microwave oven can cause interference to your radio, TV, or similar equipment.

When there is interference, it may be reduced or eliminated by taking the following measures:

1. Clean door and sealing surface of the oven.
2. Reorient the receiving antenna of radio or television.
3. Relocate the microwave oven with respect to the receiver.
4. Move the microwave oven away from the receiver.
5. Plug the microwave oven into a different outlet so that microwave oven and receiver are on different branch circuits.

IMPORTANT SAFETY INSTRUCTIONS

When using electrical appliance basic safety precautions should be followed, including the following:

WARNING: To reduce the risk of burns, electric shock, fire, or exposure to excessive microwave energy:

1. Read all instructions before using the appliance.
2. Use this appliance only for its intended use as described in this manual. Do not use corrosive chemicals or vapors in this appliance. This type of oven is specifically designed to heat, cook or dry food. It is not designed for industrial or laboratory use.
3. Do not operate the oven when empty.
4. Do not operate this appliance if it has a damaged cord or plug, if it is not working properly, or if it has been damaged or dropped. If the supply cord is damaged, it must be replaced by the manufacturer or its service agent or a similarly qualified person in order to avoid a hazard.
5. **WARNING:** Do not allow children to use oven without supervision.
6. To reduce the risk of fire in the oven cavity:
 - a. When heating food in plastic or paper container, keep an eye on the oven due to the possibility of ignition;
 - b. Remove wire twist-ties from paper or plastic bags before placing bag in oven.
 - c. If smoke is observed, switch off or unplug the appliance. **Keep** the door closed in order to stifle any flames.
 - d. Do not use the cavity for storage purposes. Do not leave paper products, cooking utensils or food in the cavity when not in use.
7. **WARNING:** Liquid or other food must not be heated in sealed containers since they are **likely** to explode.
8. Microwave heating of beverage can result in delayed eruptive boiling; therefore care has to be taken when handling the container.
9. Do not fry food in the oven. Hot oil can damage oven parts and utensils and even result in skin burns.
10. Eggs in their shell and whole hard-boiled eggs should not be heated in microwave ovens since they may explode even after microwave heating has ended.
11. Pierce foods with heavy skins such as potatoes, whole squashes, apples and chestnuts before cooking.
12. The contents of feeding bottles and baby jars should be stirred or shaken and the temperature should be checked before serving in order to avoid burns.
13. Cooking utensils may become hot because of heat transferred from the heated food. Potholders may be needed to handle the utensil.
14. Utensils should be checked to ensure that they are suitable for use in microwave oven.
15. **WARNING:** It is hazardous for anyone other than a trained person to carry out any service or repair operation which involves the removal of any cover which gives protection against exposure to microwave energy.

MICROWAVE COOKING PRINCIPLES

1. Arrange food carefully. Place thickest areas towards outside of dish.
2. Watch cooking time. Cook for the shortest amount of time indicated and add more as needed. Food severely overcooked can smoke or ignite.
3. Cover foods while cooking. Covers prevent spattering and help foods to cook evenly.
4. Turn foods over once during microwaving to speed cooking of such foods as chicken and hamburgers. Large items like roasts must be turned over at least once.
5. Rearrange foods such as meatballs halfway through cooking both from top to bottom and from the center of the dish to the outside.

UTENSILS GUIDE

1. The ideal material for a microwave utensil is transparent to microwave, it allows energy to pass through the container and heat the food. Only use a temperature probe recommended for this oven.
 2. Microwave can not penetrate metal, so metal utensils or dishes with metallic trim should not be used.
 3. Do not use recycled paper products when microwave cooking, as they may contain small metal fragments which may cause sparks and/or fires.
 4. Round /oval dishes rather than square/oblong ones are recommend, as food in corners tends to overcook.
 5. Narrow strips of aluminum foil may be used to prevent overcooking of exposed areas. But be careful don't use too much and keep a distance of 1 inch (2.54cm) between foil and cavity.
- The list below is a general guide to help you select the correct utensils.

Cookware	Microwave	Grill	Convection	Combination*
Heat-Resistant Glass	Yes	Yes	Yes	Yes
Non Heat-Resistant Glass	No	No	No	No
Heat-Resistant Ceramics	Yes	Yes	Yes	Yes
Microwave-Safe Plastic Dish	Yes	No	No	No
Kitchen Paper	Yes	No	No	No
Metal Tray	No	Yes	Yes	No
Metal Rack	No	Yes	Yes	No
Aluminum Foil & Foil Container	No	Yes	Yes	No

* Combination: applicable for both "microwave + grill", and "microwave + convection" cooking.

PART NAMES

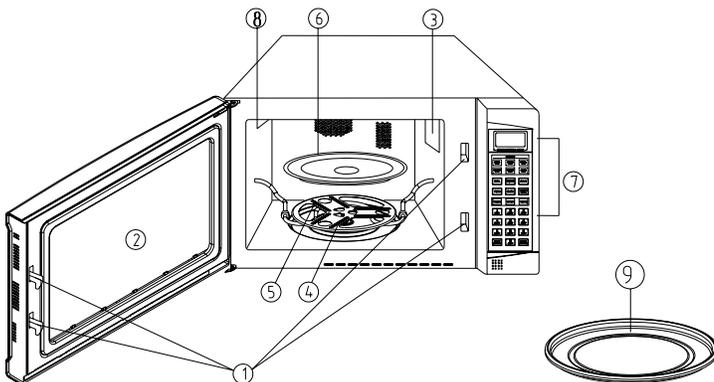

1. Door Safety Lock System
2. Oven Window
3. Oven Air Vent
4. Shaft
5. Roller Ring
6. Glass Tray
7. Control Panel
8. Grill Heater
9. Baking plate

CONTROL PANEL

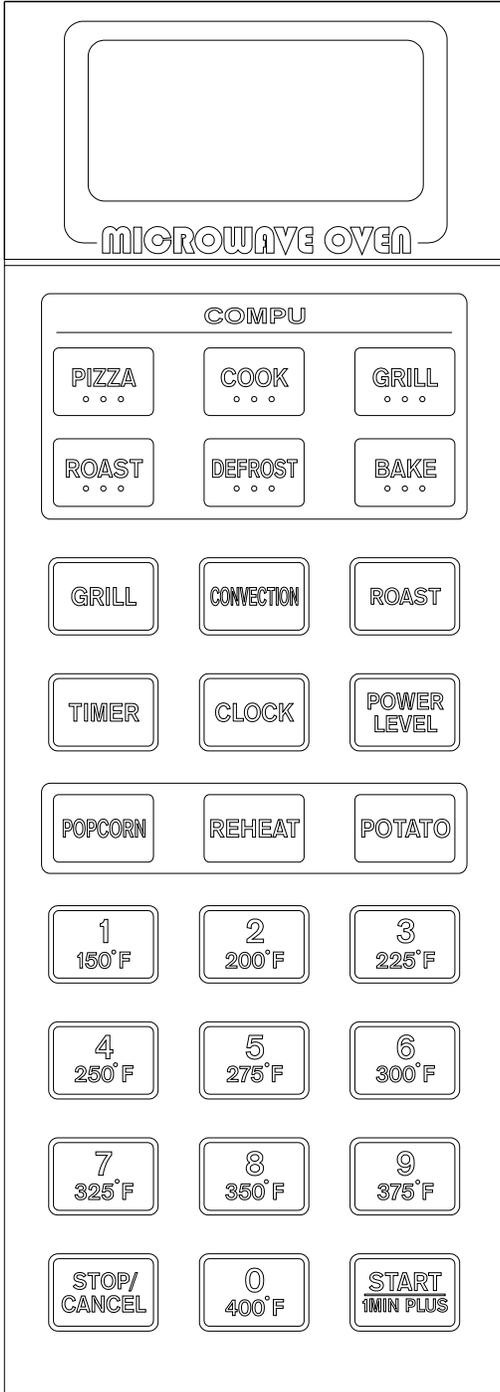

DISPLAY SCREEN

Cooking time, power, indicators and present time are displayed.

COMPU COOKING

Easy settings to cook/defrost popular food.

POWER LEVEL

Touch POWER LEVEL and then use number pads to set cooking power level.

GRILL

Press to set a grill-cooking program.

CONVECTION

Press to program convection cooking.

ROAST

Touch to roast food

CLOCK

Use to set the clock

TIMER

Use to set the oven timer

QUICK COOK PADS:

POPCORN REHEAT POTATO

START/1MIN PLUS

Press to start cooking or add to cooking time.

STOP/CANCEL

Touch to stop cooking program or clear all previous settings before cooking starts

NUMBER PADS/CONVECTION TEMPERATURE ENTRY

Touch to set cooking time, enter weight or number of servings, or program convection temperature.

(Please also see the following pages for more detail)

HOW TO SET THE OVEN CONTROLS

BEEPS DURING OVEN SETTINGS

- ◆ ONE BEEP: Oven accepts the entry.
- ◆ TWO BEEPS: Oven does not accept the entry.

Please check and try again.

SETTING THE CLOCK

The clock works in 12-hour cycle. When the oven is first plugged in, the display will briefly show “ENTER CLOCK TIME”; you can set the clock time now or later. To set the clock time later,

1. Press CLOCK pad.
2. Use the numeric pads (in the natural sequence of time) to enter clock time
3. Press CLOCK to confirm.

MICROWAVE COOKING

Microwave cooking allows you to customize cooking power and time. First, you select a power level by pressing the POWER LEVEL pad a number of times (see the table below). Then you set the cooking time (maximum 99 min. plus 99 sec.) using the numeric pads, before pressing the START pad.

Press POWER pad to select cooking power		
Press	Power	Description
once	100%(P-100)	High
twice	90%(P-90)	
3 times	80%(P-80)	
4 times	70%(P-70)	Medium High
5 times	60%(P-60)	
6 times	50%(P-50)	Medium
7 times	40%(P-40)	
8 times	30%(P-30)	Med.LowDefrost
9 times	20%(P-20)	
10 times	10%(P-10)	Low
11 times	0%(P-00)	

Suppose you want to cook for 5 minute at 60% power level.

1. Press POWER LEVEL pad 5 times
2. Press number pads to enter cooking time until the correct cooking time (5:00) is displayed.
3. Press START pad.

NOTE:

1. If you want to temporarily stop a cooking session, press the STOP/CANCEL pad once and then you can start the cooking again by press START; or press the STOP/CANCEL twice to cancel the cooking program altogether.

2. After the cooking time ends, the system will beep four times and END is displayed. Before starting another cooking session, press STOP/CANCEL pad to clear the display and reset the system.

GRILL

Grill cooking is particularly useful for thin slices of meat, steaks, chops, kebabs, sausages and pieces of chicken. It is also suitable for hot sandwiches and au gratin dishes.

Suppose you want to program grill cooking for 12 minutes use the top and bottom heaters,

1. Make sure the system is reset by pressing the STOP/CANCEL pad once.
2. Press GRILL pad up to 3 times for grill setting, in this case, press twice.

Press once	Top grill
Press twice	Top and bottom grill
Press 3 times	Bottom grill

3. Use the number pads to enter cooking time.
4. Press START pad.

NOTE:

Grill cooking power is set at full power level by the system. Maximum cooking time for grill is 99:99.

CONVECTION

During convection cooking, hot air is circulated throughout the oven cavity to brown and make crisp foods quickly and evenly. This oven can be programmed for ten different cooking temperatures.

To Cook with Convection

To cook with convection, press CONVECTION pad once and then press the number pads to enter the desired convection temperature.

Suppose you want to cook at 325°F for 40 minutes.

1. Press CONVECTION pad
2. Press number pad 7
3. Press number pads 4,0,0,0 to enter cooking time.
4. Press START pad.

NOTE:

1. The maximum convection cooking time is 99 min. 99 sec. After time has elapsed four beeps sound and END appears in display. Press STOP/CANCEL pad to clear END before starting another cooking function.
2. You can check the convection temperature while cooking is in progress by pressing the CONVECTION pad.

To Preheat and Cook with Convection

Your oven can be programmed to combine preheating and convection cooking operations.

Suppose you want to preheat to 200°F and then cook 35 minutes.

1. Press CONVECTION.
2. Press number pad 2 to indicate convection temperature 200°F
3. Press START pad. Beeps will sound when the designated temperature is reached.
4. Open the door and place container of food at the center of the turntable.
5. Use the number pads to enter cooking time.
6. Press START pad.

ROAST

This oven has four pre-programmed settings that make it easy to cook with both convection heat and microwave whereby meats can be made juicy and tender with just the right amount of browning and crispness.

Press ROAST pad and then use the number pads 1-4 to program convection temperature:

Program	Press number pad	Temp. (°F)
COMB1	1	300
COMB2	2	350
COMB3	3	400
COMB4	4	450

Suppose you want to roast for 24 minutes on COMB3.

1. Press ROAST pad
2. Use the number pads 1-4 to enter convection temperature. In this case, press number pad 3.
3. Use the number pads to enter cooking time. In this case, press number pads 2,4,0,0.
4. Press START pad to start.

NOTE:

The maximum cooking time is 99 min., 99 sec. After time has elapsed four beeps sound and END appears in display. Press STOP/CANCEL pad or open door to clear END before starting another cooking function. You can check the convection temperature while cooking is in progress by pressing the ROAST pad.

SPECIAL FEATURES

In this special feature section, you can find easy settings to cooking popular food.

POPCORN

This feature allows a regular sized bag (100g or approximately 0.22 lb) of popcorn to be popped.

1. Press POPCORN once, the display will show code and default cooking time 2:40.
2. Press START pad.

If the cooking time is not acceptable with regard to popcorn result, you can always reset the cooking time with the following steps:

1. Press POPCORN twice.
2. Use the number pads to enter a desired cooking time.

The new popcorn time will remain whenever you use the POPCORN function until you reset it again.

REHEAT

Touch the reheat pad will allow the reheating of a chilled dinner plate.

1. Press REHEAT pad once, the display will show code and default cooking time 4:10.
2. Press START pad.

POTATO

1. Touch POTATO pad once or twice for potato 4-6 oz or 5-7 oz per serving.
2. Use the number pads 1-4 to select the number of

servings.

3. Press START pad.

Please refer to the following charts for cooking guide:

1. Press POTATO pad once and use the number pads 1-4 to select number of servings (4-6 oz)

Press POTATO	Press number pad	Cooking time
1	1	3 min 50 sec
1	2	7 min 10 sec.
1	3	11 min
1	4	14 min

2. Press POTATO pad twice and use the number pads 1-4 to select number of servings (5-7 oz)

Press BEVERAGE	Press number pad	Cooking time
2	1	5 min 40 sec
2	2	10 min.
2	3	15 min.
2	4	19 min

NOTE:

After the cooking program have finished, let food stand in the oven for 5~10 minutes.

COMPU DEFROST

For 1-4 of the following food items, Compudefrost

automatically defrost foods to the weight you entered.

Cooking steps are as follows:

1. Touch DEFROST pad up to 4 times to select the type of food to be defrosted.
2. Use the number pads to enter weight of food you have placed in the oven.
3. Touch START pad.

For item 5 on the following chart, select cooking time on screen:

1. Touch defrost pad 5 times.
2. Use the numeric pads to select cooking time.
3. Press START pad.

Defrost chart

Press DEFROST	Food	Amount
Once	1. Ground meat	0.5~3.0lb
Twice	2. Steaks, chops, fish	0.5~4.0lb
3 times	3. Chicken pieces	0.5~3.0lb
4 times	4. Roast	2.0~4.0lb
5 times	5. Casserole	2~6 cups

1. If you happen to enter weight above or below the weights allowed, the screen will clear to 0.0 allowing you reenter.
2. To defrost other food, use 30% power and program defrosting time.

COMPU COOK

For items 1-3 of the following food settings, follow the steps below,

1. Indicating the type of food placed into the oven by pressing COOK pad up to 3 times,
2. Use the number pads to select cooking time,
3. Touch START pad.

For items 4-5, take the following steps,

1. Indicating the type of food placed into the oven by pressing COOK pad 4 or 5 times.
2. Use the number pads to enter food weight within the range indicated in the charts below,
3. Touch START pad.

During the cooking, beeps will be heard and cooking will automatically stop to let you turn food over for uniform cooking.

Press COOK	Items	Amount
Once	1. baked potato	1~4 medium
Twice	2. fresh vegetable	1~4 cups
3 times	3. frozen vegetables	1~4 cups
4 times	4. ground meat	0.3~1.5 lb
5 times	5. seafood, fish	0.3~1.5 lb

COMPU PIZZA

For item 1-4, take the following steps:

1. Press PIZZA up to 4 times to choose the food settings,
2. Press START pad to verify, the cooking time will appear to be counted down.

For the final item of food settings,

1. Press PIZZA 5 times,
2. Enter cooking time with number pad 1-6, and then,
3. Press START pad.

Press PIZZA	SETTING Food	Quantity
Once	1. bake frozen pizza regular crust	1
Twice	2. bake frozen pizza rising crust	1
3 times	3. bake refrig pizza	1
4 times	4. Microwave pizza	1
5 times	5. Casserole	1~6 slices

COMPU GRILL

For item 1, just press GRILL pad (with three dots below) and then use the number pads 1-7 to select cooking time before pressing START pad. For item 2-5, you need to enter food weight.

1. Press GRILL twice or up to 5 times,
2. Use the number pads to enter food weight within the range indicated in the charts below,
3. Press START pad.

During the cooking, beeps will be heard and cooking will automatically stop to let you turn food over for uniform cooking.

Press Grill	SETTING Food	Quantity
Once	1. hamburgers	1-7 (0.25lb each)
Twice	2. steaks	0.5~2 lb
3 times	3. fish steaks	0.5~2 lb
4 times	4. boneless poultry	0.5~2 lb
5 times	5. chicken pieces	0.5~3 lb

COMPU ROAST

For items 1-5 of the following food settings, take the

following steps,

1. Indicating the type of food placed into the oven by pressing ROAST pad up to 5 times.
2. Use the number pads to enter food weight within the range indicated in the charts below,
3. Touch START pad.

During the cooking, beeps will be heard and cooking will automatically stop to let you turn food over for uniform cooking.

Press ROAST	SETTING Food	Quantity
Once	1. Chicken, turkey (whole)	2.5~7 lb
Twice	2. Pork loin	2~3.5 lb
3 times	3. turkey breast	3~6 lb
4 times	4. beef eye of round	2~4 lb
5 times	5. Cornish hens	1~6.5 lb

COMPU BAKE

For item 1,

1. Press BAKE pad once,
2. Use the number pads to enter food weight within the range indicated in the charts below,
3. Press START pad.

For items 2-5 of the following food settings,

1. Press BAKE twice or up to 5 times,
2. Press START pad.

Press BAKE	SETTING Food	Quantity
Once	1. French fries	0.3~1 lb
Twice	2. Frozen snack	2~3.5 lb
3 times	3. Brownies	8"×8"×2"
4 times	4. Snack cake	8"×8"×2"
5 times	5. Biscuits	8~10 (packages of convenience biscuits)

When cooking takes place for items 3-4, the oven will firstly preheat to 350°F before reminding you to place food into the oven.

When cooking takes place for items 5, the oven will firstly preheat to 450°F before reminding you to place food into the oven.

If the preheat temperature reached, but food was not placed in soon after, the temperature in the oven will go down to a certain degree before it will restart the preheat program again. The preheating is necessary to ensure the cooking result.

OTHER CONVENIENT FEATURES

ADD TO COOKING TIME

For non-preprogrammed cooking, anytime you can add to cooking time by pressing START pad. The cooking time increases in one minute increment.

MINUTE TIMER

The timer works independently as a reminder and the time countdown ends in beeping.

1. Press TIMER
2. Use the numeric pads to enter the time to be counted down.
3. Press START.

CHILD PROOF LOCK

The child proof lock prevents unsupervised operation by little children. To set the child proof lock: Press STOP/CANCEL pad for 1.5 seconds, then a beep will sound and the indicator light will come on. In the lock state, all pads are disabled. To cancel the child proof lock: Press STOP/CANCEL pad for 1.5 seconds, then a beep will sound and the indicator light will come off.

OPERATING

1. Press STOP/CANCEL pad.
You can restart the oven by pressing START pad.
Touch STOP/CANCEL to erase all instructions.
2. Open the door.
You can restart the oven by closing the door and pressing START pad.

NOTE:

Oven stops operating when door is opened.

AUTOMATIC PROTECTION MECHANISM

Anytime in the operation of the oven, when the oven cavity temperature reaches 300°C, the oven automatically enters into self protection mode with one beeping every 1.5 sec until [the temperature decreases and STOP/CANCEL is pressed to make the oven back to normal.](#)

TO STOP THE OVEN WHILE THE OVEN IS

During grill or combination cooking, when the temperature of oven cavity is lower than 40°C after

cooking already takes place for 5 minutes; the oven will automatically enter into protection mode with the screen displaying error code E 02. This error may disappear after you press the CANCEL pad.

Error may also occur to the system sensor, which will make the oven enter into protection mode with the screen displaying E 04, and beeps can be heard. As soon as this malfunction disappears, press CANCEL, the oven will back to normal.

CLEANING AND CARE

1. Turn off the oven and remove the power plug from the wall socket before cleaning.
2. Keep the inside of the oven clean. When food splatters or spilled liquids adhere to oven walls, wipe with a damp cloth. Mild detergent may be used if the oven gets very dirty. Avoid the use of spray and other harsh cleaners as they may stain, streak or dull the door surface.
3. The outside surfaces should be cleaned with a damp cloth. To prevent damage to the operating parts inside the oven, water should not be allowed to seep into the ventilation openings.
4. Wipe the door and window on both sides, the door seals and adjacent parts frequently with a damp cloth to remove any spills or splatters. Do not use abrasive cleaner.
5. Do not allow the control panel to become wet. Clean with a soft, damp cloth. When cleaning the control panel, leave oven door open to prevent oven from accidentally turning on.
6. If steam accumulates inside or around the outside of the oven door, wipe with a soft cloth. This may occur when the microwave oven is operated under high humidity condition. And it is normal.
7. It is occasionally necessary to remove the glass tray for cleaning. Wash the tray in warm sudsy water or in a dishwasher.
8. The roller ring and oven floor should be cleaned regularly to avoid excessive noise. Simply wipe the bottom surface of the oven with mild detergent. The roller ring may be washed in mild sudsy water or dishwasher. When removing the roller ring from cavity floor for cleaning, be sure to replace in the proper position.
9. Remove odors from your oven by combining a cup of water with the juice and skin of one lemon in a deep microwaveable bowl, microwave for 5 minutes. Wipe thoroughly and dry with a soft cloth.
10. When it becomes necessary to replace the oven light, please consult a dealer to have it replaced.