

U *SER MANUAL*

C-Series

Integral Sideshifter

Manual Number 6014809-R7

cascade[®]
corporation

Cascade is a Registered Trademark of Cascade Corporation

	Page
INTRODUCTION	1
Special Definitions	1
OPERATION	1
Safety Rules	2
Industrial Lift Trucks	2
Handling Loads	3
Integral Sideshifter Operation	3
Safe Operation and Maintenance	4
OSHA Regulations	4
INSTALLATION	5
Truck Requirements	5
Recommended Hydraulic Supply	5
Installation Procedure	6
PERIODIC MAINTENANCE	8
Daily	8
1000-Hour	8
2000-Hour	8
PARTS	9
Recommended Spare Parts	9
PUBLICATIONS	9

INTRODUCTION

This User Manual is for Cascade Integral Sideshifters. Contents include an Operator's Guide, Installation Instructions, Periodic Maintenance and Parts.

NOTE: Specifications are shown in both US and (Metric) units.

IMPORTANT: C-series Sideshifter ports are SAE (9/16 in. x 18 UNF) for No. 6 O-ring fittings with 9/32 in. (7 mm) minimum ID.



WARNING: Rated capacity of the truck/attachment combination is a responsibility of the original truck manufacturer and may be less than shown on the attachment nameplate. Consult the truck nameplate.

WARNING: Do not operate this attachment unless you are a trained and authorized lift truck driver.

Special Definitions

The statements shown appear throughout this Manual where special emphasis is required. Read all WARNINGS and CAUTIONS before proceeding with any work. Statements labeled IMPORTANT and NOTE are provided as additional information of special significance or to make the job easier.



WARNING – A statement preceded by WARNING is information that should be acted upon to prevent **bodily injury**. A WARNING is always inside a ruled box.

CAUTION – A statement preceded by CAUTION is information that should be acted upon to prevent machine damage.

IMPORTANT – A statement preceded by IMPORTANT is information that possesses special significance.

NOTE – A statement preceded by NOTE is information that is handy to know and may make the job easier.

OPERATION

This section contains operating instructions for the Cascade Integral Sideshifters. It will help you avoid common errors which often cause damage to the equipment or product being handled.

This information is intended to simplify operator understanding about effective and safe sideshifter use and operation. Read this information thoroughly before operating the attachment. Be sure you know and understand all operating procedures and safety precautions. If you have any questions, or don't understand a procedure, ask your supervisor.

Emphasize Safety! Most accidents are caused by operator carelessness or misjudgment. You must watch for poorly maintained equipment and hazardous situations and correct them.

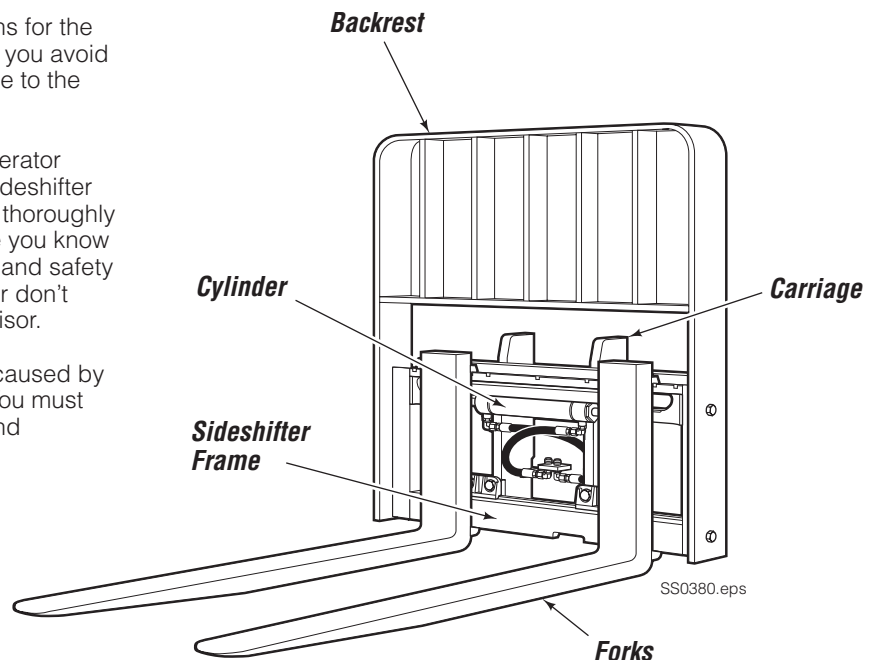

0

PERATION

Safety Rules – Industrial Lift Trucks

No riders



No reaching through mast



No standing under load



GA0047.eps

Motor off, park, lower load

Tilt
Raise 3 in. (8 cm)
Traveling empty

With load
No load
RAMPS



No parking on ramp



No turning on ramp

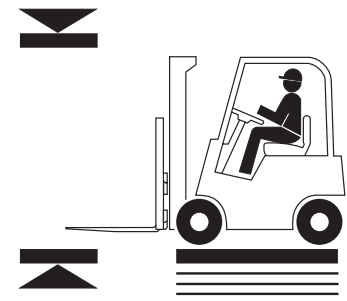

Watch clearances

GA0048.eps

TRAFFIC

Observe
Workers
Stops
Slow for two-way traffic
Sound horn, slow at intersection
Sound horn, slow at corner
Wet floors
Bumps
Dips

OPERATION

Safety Rules – Handling Loads

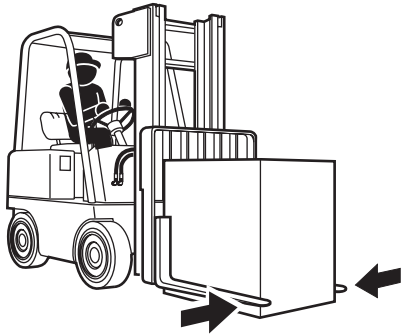

CAUTION: Do not put side loads on forks.

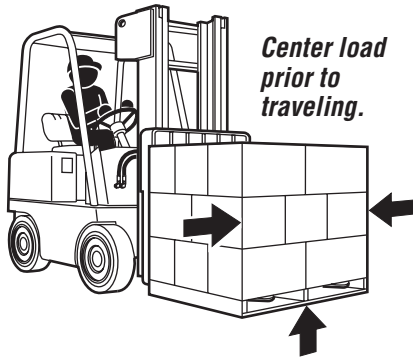

Center load prior to traveling.

Raise load prior to sideshifting.

Limit sideshifting with raised load.

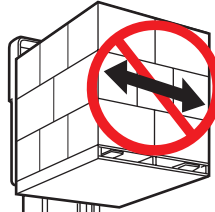

Limit truck movement with raised load.

Top of load should not extend above backrest.

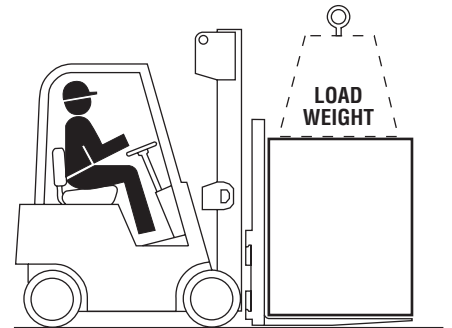
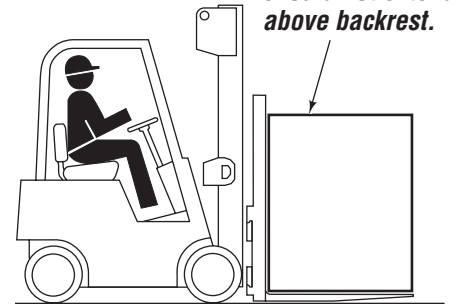

FP0174.eps

Load weight must not exceed combined truck/attachment capacity (see truck nameplate).

Total fork capacity (LH + RH fork) must be greater than load weight. Check capacity stamp on forks.

Sideshifter Operation

AUXILIARY VALVE FUNCTIONS

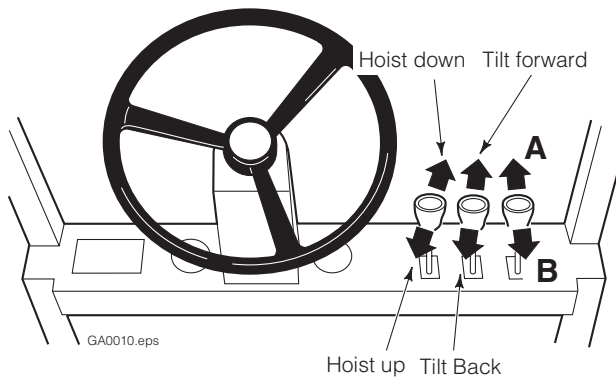

GA0010.eps

SIDESHIFTING

- A** Sideshift Left
- B** Sideshift Right

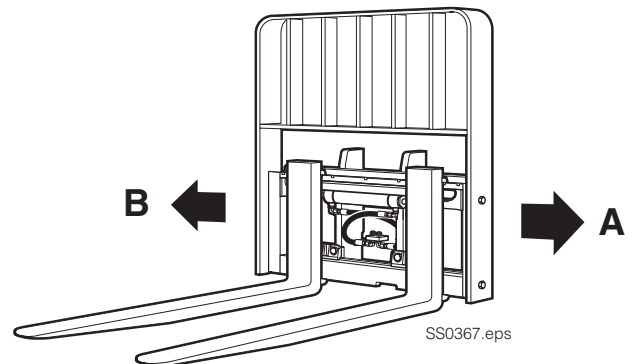

SS0367.eps



SAFE OPERATION AND MAINTENANCE

OSHA Regulations – Trucks and Attachments (Specific Regulations from OSHA 1910.178)



WARNING: The safe operation and maintenance of industrial trucks is regulated by Occupational Safety and Health (OSHA) regulations 1910.178 and American National Standards Institute (ANSI) Safety Standard for Powered Industrial Trucks, ANSI B56.1. When operating and maintaining industrial trucks equipped with attachments you should pay particular attention to the following sections of these regulations. You should be familiar with **all** sections of these regulations. **Ask your employer for the complete regulations.**

(a) General Requirement

- (4) Modifications and additions which affect capacity and safe operation shall not be performed by the customer or user without manufacturers prior written approval. Capacity, operation and maintenance instruction plates, tags or decals shall be changed accordingly.
- (5) If the truck is equipped with front-end attachments other than factory installed attachments, the user shall request that the truck be marked to identify the attachments and show the appropriate weight of the truck and attachment combination at maximum elevation with load laterally centered.
- (6) The user shall see that all nameplates and markings are in place and maintained in a legible condition.

(e) Safety Guards

- (2) If the type of load presents a hazard, the user shall equip fork trucks with a vertical load backrest extension in accordance with (a)(2) following.
 - (a)(2) All new powered industrial trucks acquired and used by an employer after February 15, 1972 shall meet the design and construction requirements for powered industrial trucks established in the "American National Standard for Powered Industrial Trucks, Part II, ANSI B56.1", except for vehicles intended primarily for earth moving or over-the-road hauling.

(l) Operator Training

Only trained and authorized operators shall be permitted to operate a powered industrial truck. Methods shall be devised to train operators in the safe operation of powered industrial trucks.

(m) Truck Operations

- (1) Trucks shall not be driven up to anyone standing in front of a bench or other fixed object.
- (2) No person shall be allowed to stand or pass under the elevated portion of any truck, whether loaded or empty.
- (3) Unauthorized personnel shall not be permitted to ride on powered industrial trucks. A safe place to ride shall be provided where riding of trucks is authorized.
- (4) The employer shall prohibit arms or legs from being placed between the uprights of the mast or outside the running lines of the truck.
- (5i) When a powered industrial truck is left unattended, load engaging means shall be fully lowered, controls shall be neutralized, power shall be shut off and brakes set. Wheels shall be blocked if the truck is parked on an incline.
- (5ii) A powered industrial truck is unattended when the operator is 25 feet or more away from the vehicle which remains in his view, or whenever the operator leaves the vehicle and it is not in his view.
- (5iii) When the operator of an industrial truck is dismounted and within 25 feet of the truck still in his view, the load engaging means shall be fully lowered, controls neutralized and the brakes set to prevent movement.
- (6) A safe distance shall be maintained from the edge of ramps or platforms while on any elevated dock or platform or freight car. Trucks shall not be used for opening or closing freight doors.

- (10) A load backrest extension shall be used whenever necessary to minimize the possibility of the load or part of it from falling rearward.

(n) Traveling

- (4) The driver shall be required to slow down and sound the horn at cross isles and other locations where vision is obstructed. If the load being carried obstructs forward view, the driver shall be required to travel with the load trailing.
- (7i) When ascending or descending grades in excess of 10 percent, loaded trucks shall be driven with the load upgrade.
- (7iii) On all grades the load and load engaging means shall be tilted back if applicable, and raised only as far as necessary to clear the road surface.

(o) Loading

- (1) Only stable or safely arranged loads shall be handled. Caution shall be exercised when handling off-center loads which cannot be centered.
- (2) Only loads within the rated capacity of the truck shall be handled.
- (3) The long or high (including multiple-tiered) loads which may affect capacity shall be adjusted.
- (4) Trucks equipped with attachments shall be operated as partially loaded trucks when not handling a load.
- (5) A load engaging means shall be placed under the load as far as possible; the mast shall be carefully tilted backward to stabilize the load.
- (6) Extreme care shall be used when tilting the load forward or backward, particularly when high tiering. Tilting forward with load engaging means elevated shall be prohibited except to pick up a load. An elevated load shall not be tilted forward except when the load is in a deposit position over a rack or stack. When stacking or tiering, only enough backward tilt to stabilize the load shall be used.

(p) Operation of the Truck

- (1) If at any time a powered industrial truck is found to be in need of repair, defective, or in any way unsafe, the truck shall be taken out of service until it has been restored to safe operating condition.

(q) Maintenance of Industrial Trucks

- (1) Any power-operated industrial truck not in safe operating condition shall be removed from service. All repairs shall be made by authorized personnel.
- (5) All parts of any such industrial truck requiring replacement shall be replaced only by parts equivalent as to safety with those used in the original design.
- (6) Industrial trucks shall not be altered so that the relative positions of the various parts are different from what they were when originally received from the manufacturer, nor shall they be altered either by the addition of extra parts not provided by the manufacturer or by the elimination of any parts. Additional counter-weighting of fork trucks shall not be done unless approved by the truck manufacturer.
- (7) Industrial trucks shall be examined before being placed in service and shall not be placed in service if the examination shows any condition adversely affecting the safety of the vehicle. Such examinations shall be made at least daily. When industrial trucks are used on a round-the-clock basis, they shall be examined after each shift. Defects when found shall be immediately reported and corrected.

Truck Requirements

Truck Relief Setting

2000 psi (140 bar) Recommended
3500 psi (240 bar) Maximum

Truck Flow Volume ^①

	Min. ^②	Recommended	Max. ^③
35C, 55C, 70C	1 GPM (4 L/min.)	2 GPM (7.5 L/min.)	3 GPM (12 L/min.)

- ① Cascade Integral Sideshifters are compatible with SAE 10W petroleum base hydraulic fluid meeting Mil. Spec. MIL-O-5606 or MIL-O-2104B. Use of synthetic or aqueous base hydraulic fluid is not recommended. If fire resistant hydraulic fluid is required, special seals must be used. Contact Cascade.
- ② Flow less than recommended will result in slow sideshift speed.
- ③ Flow greater than maximum can result in excessive heating, reduced system performance and short hydraulic system life.

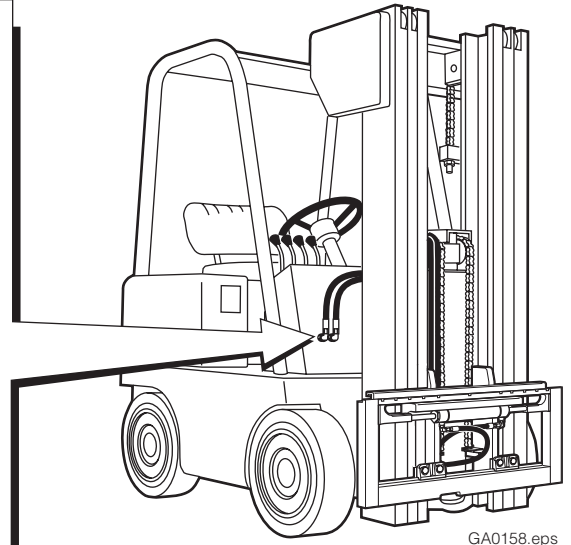

Recommended Hydraulic Supply

The Integral Sideshifter requires the hydraulic supply arrangement shown below. All hoses and fittings should be No. 6 with 7/32 in. (7 mm) minimum ID.

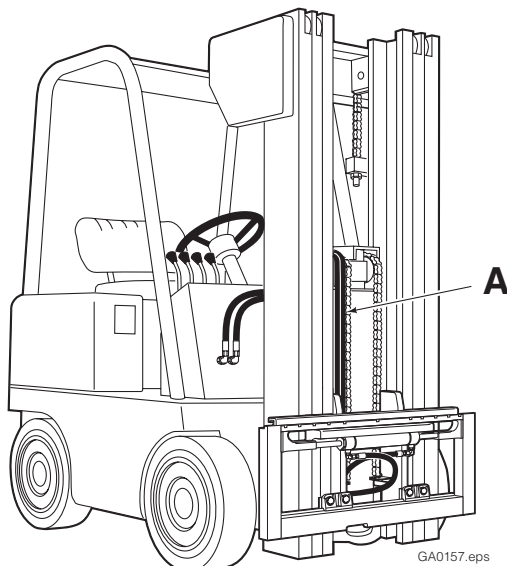

Auxiliary Valve Functions

Check for compliance with ITA (ISO) standards:

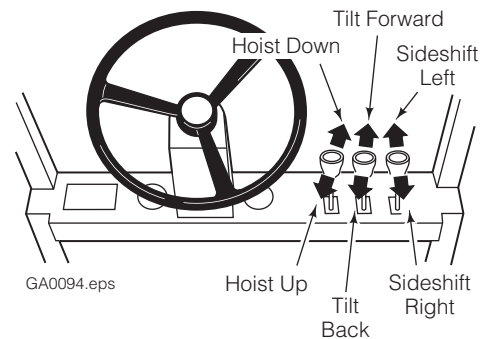

A Mast Single Internal Reeving

Installation Procedure

IMPORTANT: Integral attachment installation is an OEM or dealer responsibility. Some of the following steps may or may not be required, but are shown for reference. Refer to the appropriate service manual for service and repair procedures.

- 1** Integral Sideshifter carriage should be installed in mast per OEM specifications and procedures.

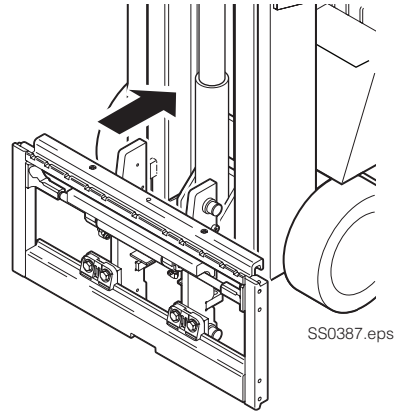

- 2** Check lower hook clearance

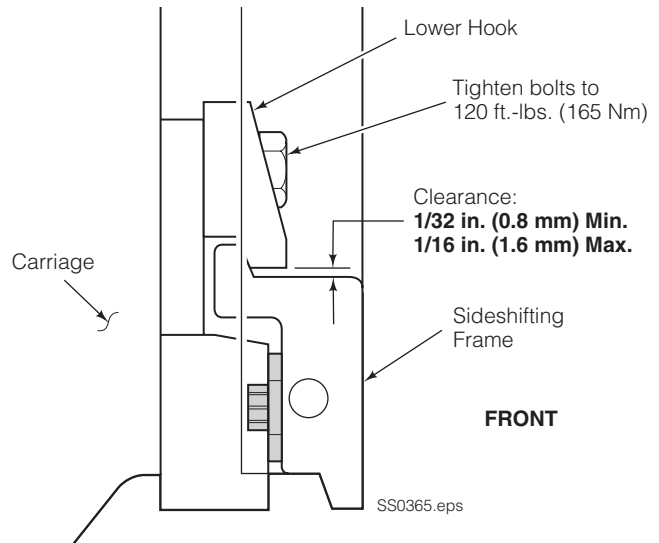
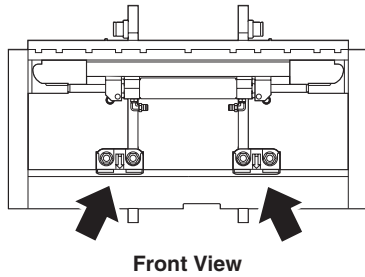

- 3** Flush supply hoses

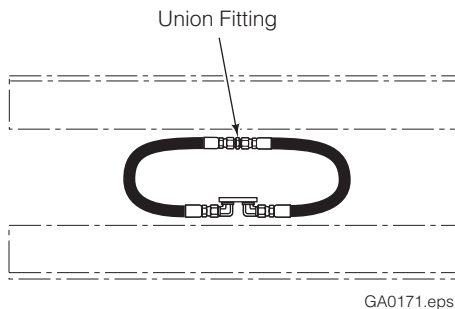

- 4** Connect hoses

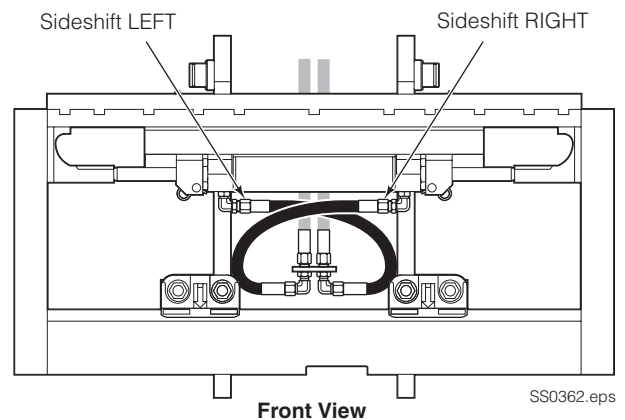

5 Install forks

Use pallet or blocks as necessary to raise forks to installation height. Keep feet clear of forks when installing.



WARNING: If the fork locking pin is not fully engaged, the fork could become disengaged from the carriage.

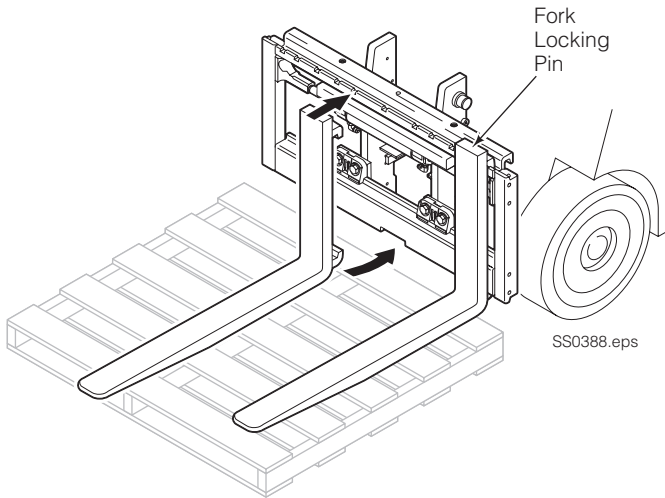

6 Install backrest

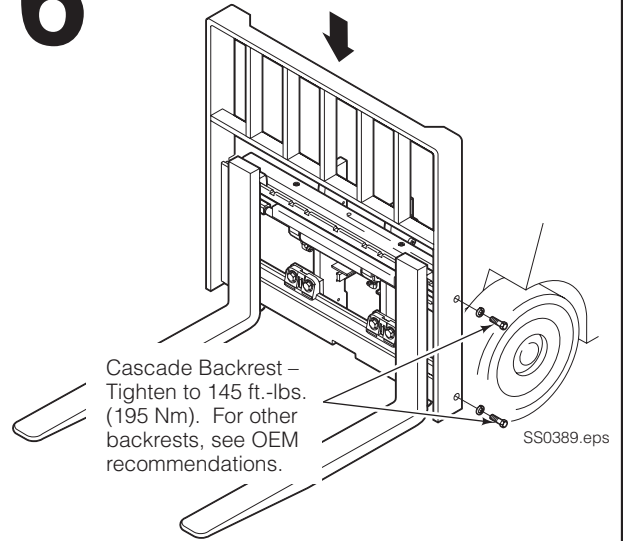

7 Check Sideshifter bearing lubrication

Bearings are prelubed at the factory with break-in grease. **No additional lubrication is required during installation.**

NOTE: After 600 hours of operation, sideshifter bearings should be lubricated with general-purpose chassis grease.

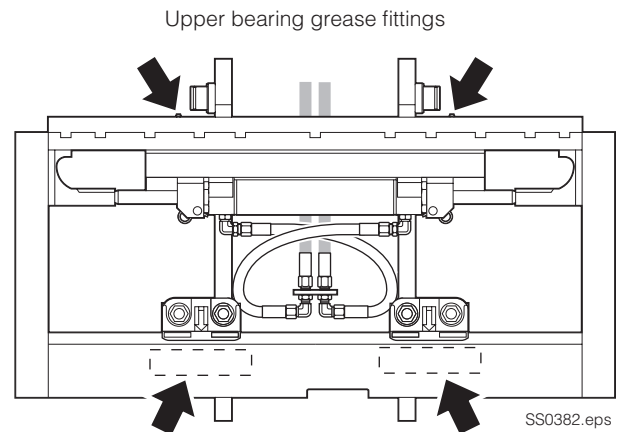

Lower bearing grease areas

Front View

Daily

Check items shown each day. Report problems to your supervisor. See Service Manual for troubleshooting, maintenance and repair procedures.

NOTE: Carriage should be maintained per OEM service specifications.

IMPORTANT: Visually check wear on lower hook and capscrew conditions.



WARNING: If the fork locking pin is not fully engaged, the fork could become disengaged from the carriage.

- Check for loose or missing bolts, worn or damaged hoses, hydraulic leaks, and damaged or missing fork stops.
- Check decals and nameplate for legibility.

1000-Hour

Every time the lift truck is serviced or every 1000 hours of truck operation, whichever comes first, complete the following maintenance procedures:

- Tighten backrest capscrews (Cascade) to 145 ft.-lbs. (195 Nm). For truck manufacturer's backrest, refer to truck service manual.
- Inspect lower hooks for wear and proper clearance. Adjust if necessary, refer to Installation, step 4. Tighten lower hook capscrews to 120 ft.-lbs (165 Nm).
- Lubricate Sideshifter upper and lower bearings with general-purpose chassis grease.
- Inspect upper and lower bearings for wear. If any bearing is worn to less than 3/32 in. (2.5 mm) thickness, replace the entire bearing set. Refer to service manual for replacement procedure.

2000-Hour

After 2000 hours of truck operation, in addition to the 1000-hour maintenance, forks in use shall be inspected at intervals of not more than 12 months (for single shift operations) or whenever any defect or permanent deformation is detected. Severe applications will require more frequent inspection.

Fork inspection shall be carried out by trained personnel to detect any damage that might impair safe use. Any fork that is defective shall be removed from service. Reference ANSI B56.1-2005.

Inspect for the following defects:

- Surface cracks
- Straightness of blade and shank
- Fork angle
- Difference in height of fork tips
- Positioning lock
- Wear on fork blade and shank
- Wear on fork hooks
- Legibility of marking

NOTE: Fork Safety Kit 3014162 contains wear calipers, inspection sheets and safety poster. Also available is fork hook & carriage wear gauge 209560 (Class II) and 209561 (Class III).



WARNING: After completing any service procedure, always test the Integral Sideshifter through five complete cycles. First test with no load, then test with a load to make sure the sideshifter operates correctly before returning it to the job.

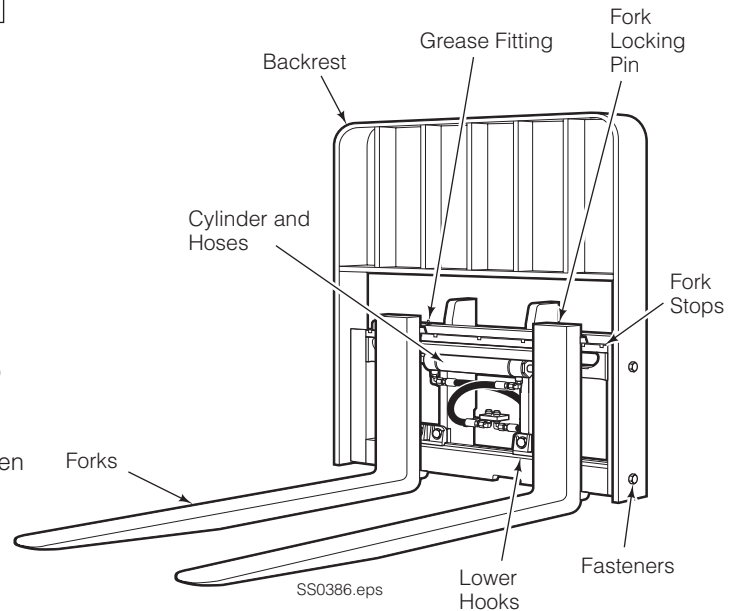

PARTS

Recommended Spare Parts

Product Identification – This section shows replacement parts for integral sidershifters. The product model number and serial number are stamped on the inside surface of the RH vertical sideplate (driver's view) and must be provided when ordering replacement parts. The cylinder assembly part number is stamped on the LH frontside (driver's view).

WARNING: For the safety of yourself and others, DO NOT install the parts shown in this manual unless you have thoroughly reviewed the appropriate service manual.

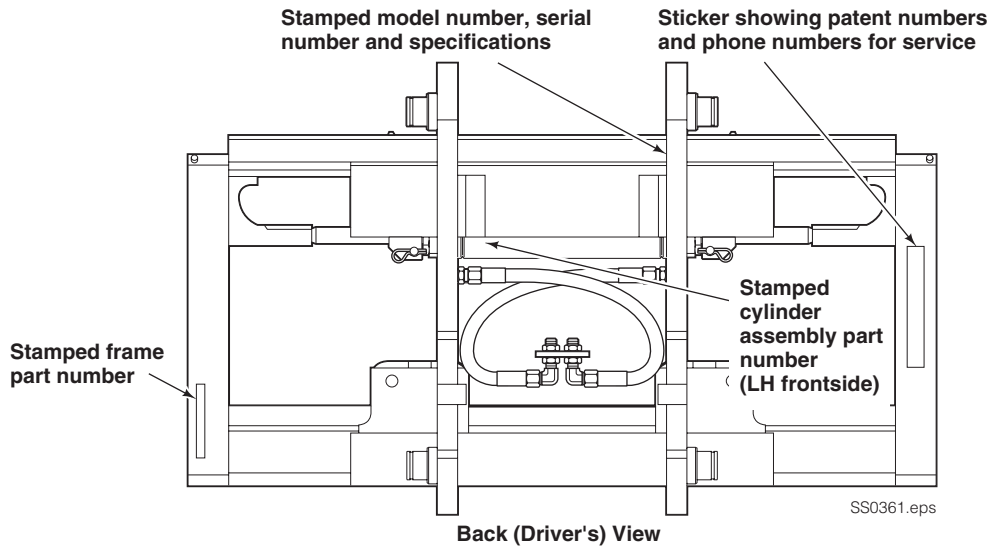

35C, 55C, 70C Integral Sidershifter		UNITS SERVICED		
PART NO.	DESCRIPTION	1-5	6-19	20-50
		QTY.	QTY.	QTY.
BASE UNIT				
■	Upper Bearing, Composite	8	16	32
■	Lower Bearing, Composite	6	12	24
8508373	Lower Hook	0	2	4
684295	Capscrew, M16 x 35	0	4	8
667225	Washer, HD, M16	0	4	8
CYLINDER				
6020048	Cylinder Assembly	0	0	1
6019928	Rod Seal Service Kit	1	2	4

■ See specific parts page for part number.

PUBLICATIONS

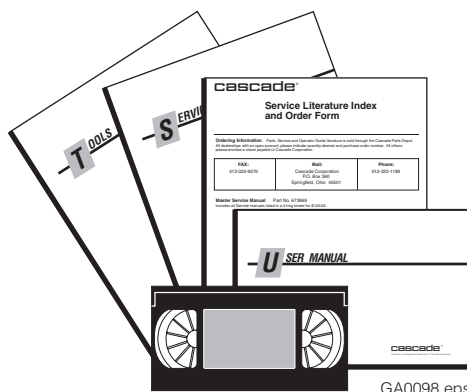

PART NO.	DESCRIPTION
6014809	User Manual
6020275	Service Manual
679929	Tool Catalog
673964	Literature Order Form

Do you have questions you need answered right now?

Call your nearest Cascade Service Department.

Visit us online at www.cascorp.com

AMERICAS

**Cascade Corporation
U.S. Headquarters**

2201 NE 201st
Fairview, OR 97024-9718
Tel: 800-CASCADE (227-2233)
Fax: 888-329-8207

Cascade Canada Inc.

5570 Timberlea Blvd.
Mississauga, Ontario
Canada L4W-4M6
Tel: 905-629-7777
Fax: 905-629-7785

Cascade do Brasil

Rua João Guerra, 134
Macuco, Santos - SP
Brasil 11015-130
Tel: 55-13-2105-8800
Fax: 55-13-2105-8899

EUROPE-AFRICA

**Cascade Italia S.R.L.
European Headquarters**

Via Dell'Artigianato 1
37030 Vago di Lavagno (VR)
Italy
Tel: 39-045-8989111
Fax: 39-045-8989160

Cascade (Africa) Pty. Ltd.

PO Box 625, Isando 1600
60A Steel Road
Sparton, Kempton Park
South Africa
Tel: 27-11-975-9240
Fax: 27-11-394-1147

ASIA-PACIFIC

Cascade Japan Ltd.

2-23, 2-Chome,
Kukuchi Nishimachi
Amagasaki, Hyogo
Japan, 661-0978
Tel: 81-6-6420-9771
Fax: 81-6-6420-9777

Cascade Korea

121B 9L Namdong Ind.
Complex, 691-8 Gojan-Dong
Namdong-Ku
Inchon, Korea
Tel: +82-32-821-2051
Fax: +82-32-821-2055

Cascade-Xiamen

No. 668 Yangguang Rd.
Xinyang Industrial Zone
Haicang, Xiamen City
Fujian Province
P.R. China 361026
Tel: 86-592-651-2500
Fax: 86-592-651-2571

**Cascade India Material
Handling Private Limited**

No 34, Global Trade Centre
1/1 Rambaugh Colony
Lal Bahadur Shastri Road,
Navi Peth, Pune 411 030
(Maharashtra) India
Phone: +91 020 2432 5490
Fax: +91 020 2433 0881

Cascade Australia Pty. Ltd.

1445 Ipswich Road
Rocklea, QLD 4107
Australia
Tel: 1-800-227-223
Fax: +61 7 3373-7333

Cascade New Zealand

15 Ra Ora Drive
East Tamaki, Auckland
New Zealand
Tel: +64-9-273-9136
Fax: +64-9-273-9137

**Sunstream Industries
Pte. Ltd.**

18 Tuas South Street 5
Singapore 637796
Tel: +65-6795-7555
Fax: +65-6863-1368

