

# **THREE.2<sup>tm</sup> In-Dash**

**System Controller, Precision Equalizer,  
Crossover with Auxiliary Inputs**

**Owner's Enjoyment Manual**

# **AudioControl<sup>®</sup>**

**Making Good Sound Better<sup>®</sup>**

22410 70th Avenue West • Mountlake Terrace, WA 98043 USA • Phone 425-775-8461 • Fax 425-778-3166

This page intentionally left blank.

## Table Of Contents

Introduction.....	1
Features and Highlights.....	3
A Guided Tour of the THREE.2.....	5
Installation.....	8
Placement and Mounting.....	8
Power Wiring.....	9
Audio Wiring.....	10
Level Matching.....	12
Adjusting the equalizer.....	13
Crossover Modules.....	14
Troubleshooting.....	15
Warranty.....	16
Specifications.....	17

## Introduction

**Congratulations** on your purchase of a truly unique and versatile product, the AudioControl THREE.2, the latest and greatest in the family of AudioControl in-dash signal processors. More than just an equalizer, the THREE.2 is a complete system controller/pre-amp, just like you find in the best audiophile home sound systems. The THREE.2 not only improves the sound quality and performance of any amplified car audio system but, it provides you with an audiophile quality 24dB/octave electronic crossover. This new THREE.2 expands your system choices by providing dual Auxiliary Inputs. Now you can plug a friend's iPod into your system at any time. No fuss, no muss. The THREE.2 is the ideal combination of features and improved performance for any car audio enthusiast, regardless of whether you are a dyed in the wool sound-off competitor or you just want to crank your system up until the nearby buildings shake.



It's all about sound quality and choice...yours. The THREE.2 will let you tune your system to what you like, and use whatever source you want to use...when you want to use it. In the words of Mel Brooks "It's good to be the King"

Now sit back and grab a home brew and peruse through this Enjoyment Manual for the THREE.2 in-dash equalizer.

## Features of the THREE.2

- Stereo graphic equalization
- Front and Rear, Dual Auxiliary inputs
- Para-BASS® low frequency contouring
- Selectable Cool Blue or Hot Red back-lighting
- 24dB/Octave Linkwitz Riley crossover
- Pre-amp gain of 20dB
- Line driver: 13 volts peak output
- Subwoofer level control
- High headroom PWM switching power supply
- Master volume and fader control
- LED Voltage Indicator

## QUICK INSTALLATION INFO

For those of you who are short on time and brimming with confidence, or caffeine for that matter, refer to pages 8 to 13 (Figures 6, 7, 8 and 9). As a matter of reference the THREE.2 is shipped in the following configuration:

	<b>Shipped</b>	<b>Option</b>	<b>Page</b>
Main Input	Unbalanced	Balanced	6
Aux Inputs	Balanced	Unbalanced	6
Ground Isolation	Isolated	200 ohm or Ground	7
Input Gain	Unity	0 to +20dB	7
Crossover frequency	90 Hz	30Hz - 3500Hz	7
Illumination Color	Cool Blue	Hot Red	7

AudioControl builds high performance, technical products and we invest considerable time training with our dealers to get the maximum performance from each product. That is why we recommend that you consider having your authorized AudioControl dealer install your THREE.2. In fact, if he or she installs your THREE.2, we will extend your warranty to an unbelievable 5 years parts and labor. Should you opt to install the THREE.2 on your own, we will warranty it for 1 year parts and labor.

## FEATURES AND HIGHLIGHTS

The following section will tell you about all of the nifty features of your THREE.2. Knowing these features will help you maximize the performance of your THREE.2 in-dash pre-amp/equalizer/crossover. You will also score points with your fellow autosound buddies.

**Graphic Stereo Equalization:** The THREE.2 turns the dashboard of your car into a mini-mixing board, just like that in a recording studio. The THREE.2 has three frequency controls set at 125Hz, 1.25KHz, and 10KHz respectively. The frequencies were selected to provide you with a just enough control to make dramatic improvements in any system.

**Para-BASS®:** You want bass, we got bass. This specially designed equalizer control lets you adapt the bass response of any system to your listening desire. Given all of the various types of music combined with numerous possible bass response anomalies in every vehicle, a single control for bass just doesn't cut it. It's like painting a picture with only one color...BORING!

**Input Selection:** The THREE.2 provides a "Main" RCA input on the back panel of the unit. It also provides two choices for an Auxiliary input. One is on the back panel for a

permanent Aux-in, and the other is located on the front panel. If you just want to be able to plug an iPod in on occasion, then you can use the front panel 1/8" input. Also, the THREE.2 Aux-ins have been optimized with extra gain to compensate for weak signals from iPods and other MP3 players.

**24dB/Octave Linkwitz Riley Crossover:** What is the benefit of fine tuning your system if you cannot accurately route the proper frequencies to the proper amplifier channels? The programmable audiophile crossover in the THREE.2 is the same crossover in many other award winning AudioControl components. Know who else gives you a 24dB Linkwitz-Riley in their in-dash EQ? Nobody! This is also a far cry from the wimpy crossovers that find their way into some amplifiers these days.

**Pre-Amp Line Driver:** Talk about your ironies. Amplifiers require a high voltage input signal (generally 2 to 5 volts) to operate with maximum dynamic range and the best signal-to-noise ratio. On the other hand, typical source units only produce 1 to 2 volts, if your lucky. In a system where the source unit is located in the front of the car and the amplifier(s) are located in the rear, the length of the connecting cables can have a negative impact on the strength of the signal. The THREE.2 includes a line driver that takes the weak

output voltage of a head unit and increases it 20dB (up to 13 volts peak) and then delivers it downstream to the amplifier inputs.

**Master Volume:** The THREE.2 has a big master volume KNOB (no annoying up & down switches for us) to control the signal output to the amplifiers. Raise the volume level on your source units to their maximum and you will never need to touch them again.

**Subwoofer Level Control:** Need a little more bass to impress your buddies? Or maybe you want to tone it down so you don't scare off your date. Whatever the case, the THREE.2 has a subwoofer output level control that allows you to balance the amount of signal that goes to your subwoofer outputs.

**Fader Control:** The THREE.2 has 4 output channels and a fader control to allow for easy balancing between the front and rear speakers.

**AudioControl's Bulletproof Reliability.** That's right, your AudioControl THREE.2 comes with a full 5 year parts and labor warranty when it is installed by an authorized United States AudioControl dealer. These seasoned pro's have the training and the equipment to take care of the job quickly

and not leave your dashboard looking like Swiss cheese. Keep in mind that if you or your friends are "good with electronics" and choose to install it yourself, your THREE.2 still has a 1 year parts and labor warranty. To activate your warranty, just go on-line to [audiocontrolregistration.com](http://audiocontrolregistration.com) and fill out the requested information. Also, save your invoice or sales slip as proof of purchase. Not only is this necessary for warranty purposes, it's also important if the unforeseen disappearance of your THREE.2 should happen while you are socializing at the local espresso and salmon bar. Insurance companies have very little imagination.

**Illumination:** The THREE.2 illuminates so you can see what your doing at night with either Cool Blue or Hot Red back-lighting. You get to pick the color that fits you best.

## A GUIDED TOUR OF THE THREE.2

**1. Aux Input:** An 1/8" jack on the front panel allows an Auxiliary input to be plugged in quickly and easily at any time. Plugging into the front Aux In jack will automatically override the Rear Aux In. When you unplug from the front jack, the rear jack will again be active. Cool eh?

**2. Graphic Equalization Bands:** Three stereo controls centered at 125Hz, 1.25KHz, and 10 KHz with 12dB of boost or cut. These controls should be used to tweak your system, depending upon your mood or program material.

**3. Para-BASS® Controls:** Two simple controls allow for killer bass tweaking. The sweep knob selects the center frequency, between 40 and 80Hz. The gain knob provides 12dB of boost or cut, centered around the sweep frequency.

**4. Subwoofer Level Control:** Exactly what it says it

is. Controls the amount of signal that goes to the sub-woofer output of your THREE.2.

**5. Fader:** When amplifier channels are connected to the front and rear outputs, the fader control will allow you to fade the signal level back and forth. This also means you can have front and rear fading even though your source unit only has 2-channel outputs.

**6. Volume:** Because the THREE.2 is a true pre-amp, it serves as the main control unit in the audio system. It has a master volume control that controls the output to all of your amplifiers. The best signal-to-noise ratio (and therefore the best sound quality) from your head unit is at about 3/4 volume. Now, you can turn the head unit up to where it sounds best and then use the volume knob of the THREE.2 to give your amps the cleanest signal at the volume you want to listen to. Result? The best sound at every volume level.

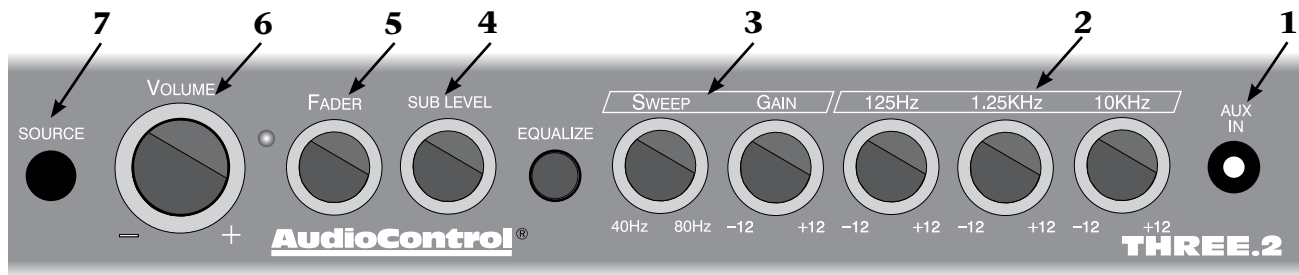

Figure 1: Front View of THREE.2

**7. Source:** The source button lets you pick between the MAIN differentially balanced input and the active Auxiliary input

**8. Input Jacks:** The THREE.2 has three sets of inputs, MAIN plus two Auxiliaries. MAIN inputs should get their

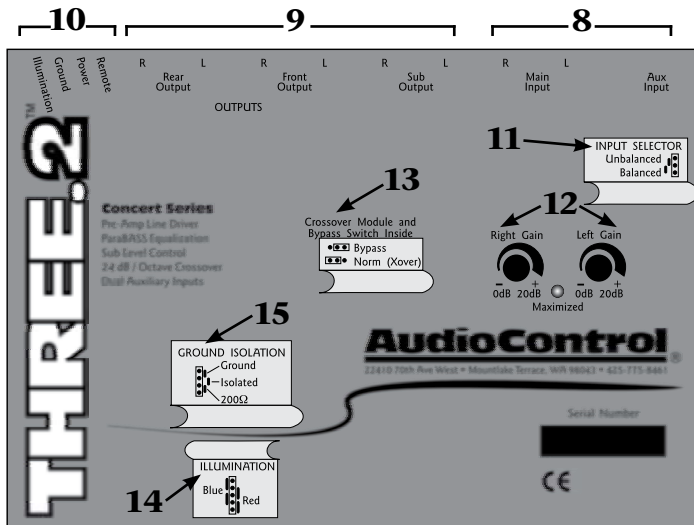

Figure 3: Top View of THREE.2, with a peek at what's inside

signals from the main source unit/head unit and attach to the RCA jacks. Auxiliary inputs will plug into the 1/8" jack on the back panel input for permanent connection or into the front panel jack for temporary use. Connecting the Front and Rear panel Aux inputs at the same time will cause no damage to the units, but it may create a tear in the time space continuum. Actually when you plug into the front input the THREE.2 will automatically shut off the rear panel input

**9. Output Jacks:** Next to the inputs are the outputs, which should be connected to the front, rear and subwoofer amplifiers, if applicable.

**10. Power Connections:** This nifty connector is a blessing to anyone who has tried to wire up their gear with their head crammed under the dash. You can wire up the power, ground, remote turn-on, and illumination from the convenience of the drivers seat and then casually plug it in the back of your THREE.2.

**11. Balanced Input Selector:** Located under the cover and behind the Input connectors are jumpers that allow you utilize or bypass the balanced input circuitry. Although it is



shipped in the unbalanced mode, which is often best, it may be necessary to change this depending upon the configuration of the components you use. To change this, move the appropriate jumper on the 3-pin header.

**12. Input Gain Control:** These potentiometers (aka “pots”) are used to increase the amount of signal voltage to your power amplifiers. With these controls you can provide up to 13 Volts (peak) to your amplifier’s inputs. Check with your amplifier manufacturer’s specs to determine exactly how much voltage they can really handle. More info on this in the section on “Level Matching” page 12.

**13. Crossover Frequency Selection:** Under the top cover of your THREE.2 lies a plug-in module that controls the crossover frequency. The module selects the frequency that the front and rear outputs of your THREE.2 will play down to as well as determining where your subwoofer will begin playing. The jumper lets you defeat the crossover, so if your system does not use a separate subwoofer, all your amplifiers will get a full range signal.

**14. Illumination Selection:** These jumpers let you change the backlight illumination to Cool Blue or Hot Red.

Given that we are acclimated to sun free life in the rainforest, we have shipped the THREE.2 in the Cool Blue mode.

**15. Ground Isolation Selector:** This feature allows you to change the power supply ground for different systems. When the THREE.2 is shipped from the factory, the selector is in the fully isolated position (which is generally the best). Alas, not every manufacturer devotes so much time into getting its grounds right. Therefore, we have provided other ground isolation options to help if you have a ground loop noise (alternator whine) in your system. Experiment with different settings if you run into this type of problem. To change the settings, turn the system off, carefully move the black jumper from the center two pins (Isolated) and move it to either the top two pins (200ohm) or the bottom two pins (Ground).

**Now:** If you don’t feel comfortable with everything you have read up to this point, run, don’t walk to your nearest authorized AudioControl dealer and let them install it. Life is too short to be tearing your hair out over your car audio system.

## INSTALLING YOUR THREE.2 IN-DASH SYSTEM CONTROLLER

Having absorbed everything in the manual up to this point, then you probably know we endorse having a professional install your THREE.2, as it would be in your best interest for performance and it will extend your warranty to 5 years. Above and beyond having all of the appropriate technical know-how and experience, they have lots of cool tools. If you are still with us and are feeling confident, then read on...

### A. Placement and Mounting the THREE.2 In-Dash Equalizer/Crossover

**Placement:** By definition, the THREE.2 in-dash equalizer was designed to be installed on or near the dashboard of most cars. However, if you are building a real trick system, like with a separate audio system in the front and a separate one in the rear of a vehicle, the THREE.2 is an ideal pre-amp control that can be mounted in the front and/or the rear of the vehicle.

**Mounting:** The THREE.2 is flexible enough to mount almost anywhere, although somewhere on the dash or in a center console is the most logical. You will want to be able to access it while you are sitting in the driver's seat of your



Figure 3: THREE.2 with mounting brackets

vehicle. The THREE.2 is designed to be physically mounted almost anywhere in a vehicle, although it is recommended to avoid hot spots like the firewall, engine compartment, or tail pipe. The mounting location must also be safe from water seepage or areas with bad seals (rubber gaskets, not sleek furry mammals who eat salmon). If there are old water stains, be wary of leaks and stay away. We have provided brackets to assist you in mounting the THREE.2 chassis under the dashboard or glove box. The screw holes on the THREE.2 chassis also allow for easy installation underneath a radio or with a dash kit. It is of utmost importance to mount the THREE.2 securely to avoid any undue stress or breakage from over acceleration or braking.

## B. THREE.2 Power Wiring

• **ENLIGHTENING INFO** • Disconnect the negative terminal of your car's battery before working on any electrical connections. Failure to do so could lead to a dramatic spark in your life.

**Remote Turn-On:** Connect a 22 to 18 gauge wire from the head-unit's remote turn-on to the "Remote" connector on the THREE.2.

**Positive(+12V) Connection:** Insert an 18 gauge or larger wire into the connector labeled "Power" on the nifty connector of your THREE.2. Connect it to a good, constant fused source of 12 volts (we suggest the battery).

**Ground Connection:** Use the same gauge wire as you did for the positive connector and run it from the "Ground" connector on the THREE.2 to the negative terminal of the battery, a ground buss, or a verified ground location. The factory head unit ground is *not* recommended.

**Illumination:** The connector labeled "Illumination" on your THREE.2 provides power to the backlighting of your unit. Connecting it to a switched 12 volt source, such as the "Remote" will light up the backlighting of your THREE.2. A really cool idea is to connect the illumination wire to a factory dash light dimmer and have the ability to dim the backlighting of the THREE.2 with your dash lights.

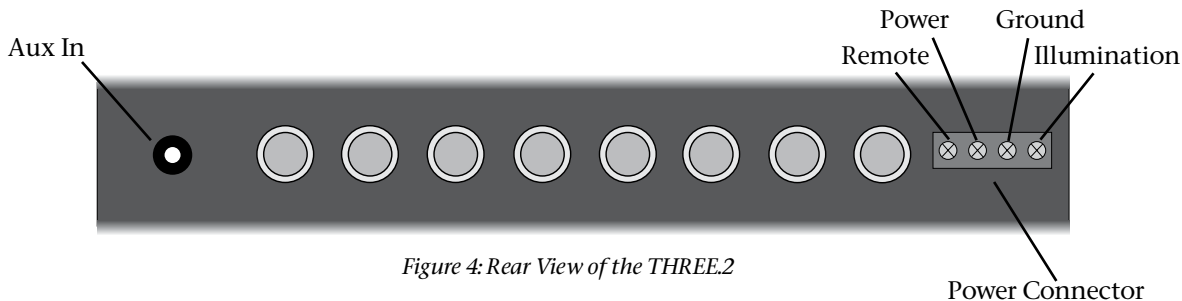

Figure 4: Rear View of the THREE.2

## C. THREE.2 Audio Wiring

**Planning:** As you may already have guessed, there are numerous ways to configure the THREE.2 in your audio system. Spend a little quality time planning out your system and even sketching it out on paper if you can. The following diagrams are just a few of the possibilities.

### Front, rear and subwoofer amplifier

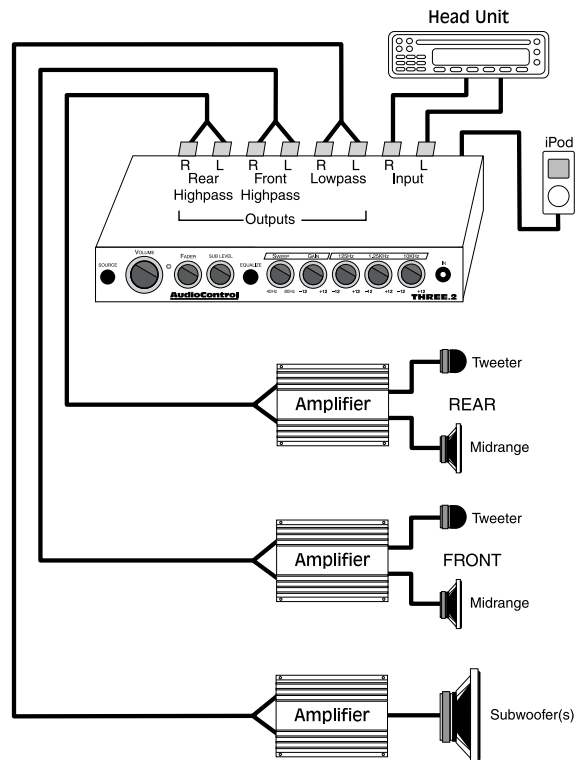

Figure 5: THREE.2 with source unit, iPod, and three amplifiers

## Four channel and subwoofer amplifier

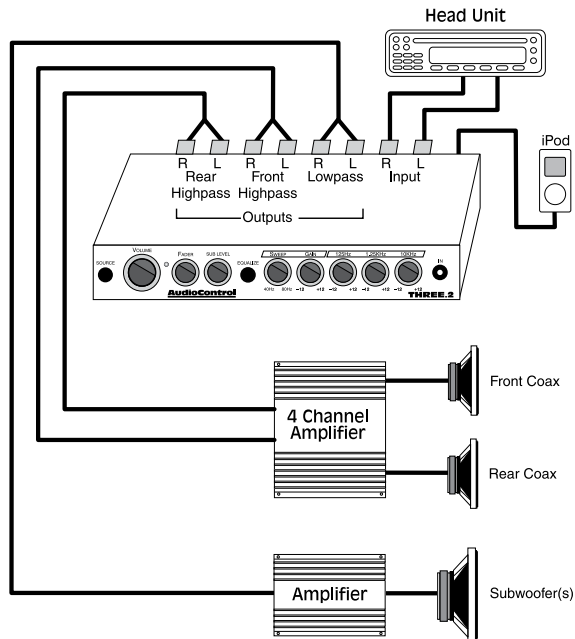

Figure 6: THREE.2 source unit, 4 channel amp and sub amplifier

## RV/Boat without a fixed source unit

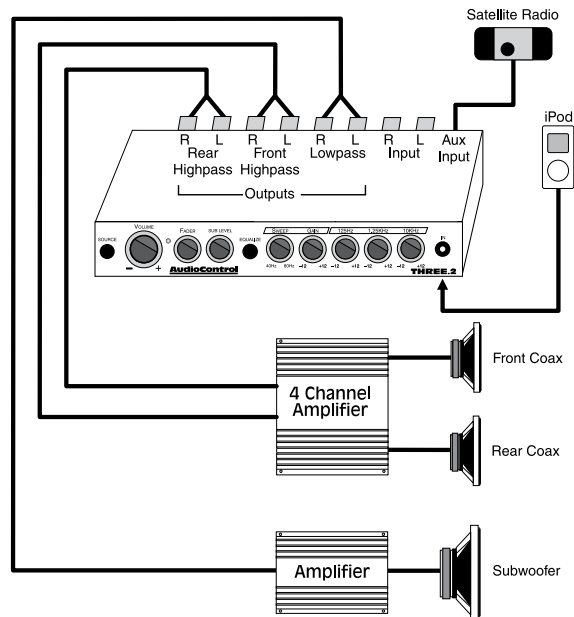

Figure 7: The THREE.2 can be mounted into a boat or RV and iPod can be a removable source unit

## Simple 2-way system

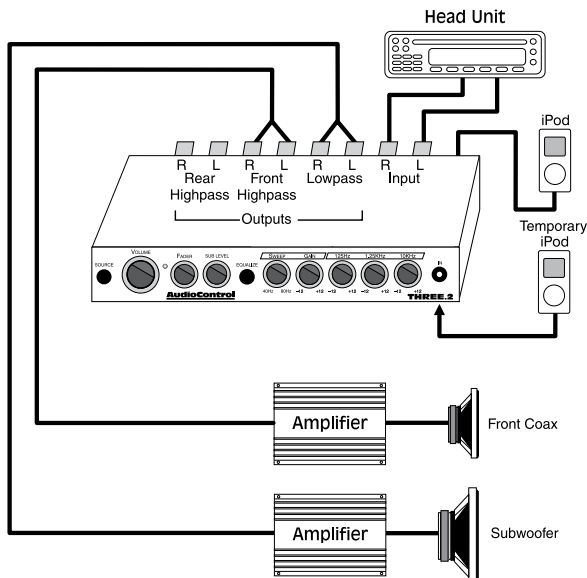

Figure 8: THREE.2 with source, iPod, front amp, and sub amp

## D. Level Matching

Many manufacturers claim that their source units produce signal voltages in the area of 2 to 4 volts. However, what they neglect to mention is that you only achieve these incredible voltage levels when the volume is turned all the way up. Try listening to that all of the time. By following the level matching steps for the THREE.2 you will be able to take full advantage of the high voltage output of your head unit.

1. Disconnect the RCA cables leading into your amplifiers, and make sure the only RCA cables between your head unit and the THREE.2's main inputs are attached. Turn the volume level knob on the THREE.2 to maximum.

2. Play a favorite compact disc or MP3 that contains consistent, dynamic music and turn the source unit's volume control up to its maximum level (NOTE: Some source units may produce distortion or "clipping", when their volume controls are turned all of the way up. If this happens, you will hear distortion even at low levels when you connect the rest of the system. If this is the case, lower the source unit's volume level until you no longer hear distortion). The volume control on the THREE.2 will now be the master volume control.

3. Using a small screwdriver, adjust the “Input Gain” control on the top of the THREE.2 until the yellow “Maximized” LED starts to flicker with the music (NOTE: If the Maximized light does not come on, because of the low output of the source unit, turn the Input Gain pot to maximum).

4. Turn off the entire system and attach the output RCA's from the THREE.2 to the next component in line.

### • Important Tip •

If the Maximized light does not come on, because of the low output of the source unit, turn the Input Gain to maximum. Please refer to the amplifier manufacturers specifications on input voltage to determine whether you will need to decrease the “Input Gain” on the THREE.2 to avoid clipping the next component in line. If the next component in line is an AudioControl component, there is no need to re-adjust the “Input Gains”, because they can handle the hot signal voltage the THREE.2 produces.

5. Turn down the gain control on your amplifiers to the least sensitive setting which is turning the gain control counter clockwise. This will allow you to drive a hotter signal in to your amplifiers. For more info on this, download Tech Note 1006 from our web site.

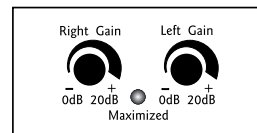

Figure 9: Input Gain Controls

## E. Adjusting The Equalizer

**Stereo Bands:** There are no specific guidelines as to setting the main equalizer controls on the THREE.2. Keep in mind that music can sound different depending upon who is listening and what type of music they are listening to. For some mid-bass kick, give the 125Hz knob a whirl. On the other hand if your front and rear speakers are having trouble keeping up with your subwoofer than crank 125Hz down a notch. If the vocals need some boosting or even toning down, us the 1.25KHz controls. The frosting on any recording is always the higher frequencies. The 10KHz control lets you provide just enough frosting or you can cut back so you don't get any cavities. There is no need to re-adjust the “Input Gains”, because they can handle the hot signal voltage the THREE.2 produces.

**Para-BASS® Controls:** The Para-BASS® system control works with any system that can reproduce bass in the 40-80Hz range. The bass response in a system is affected by four factors (1) the acoustics of the vehicle, (2) the location of the speakers, (3) the music source you are listening to and (4) the speakers used. Because of the variations in the recording process, we developed The Epicenter™ to help restore any low frequencies lost during the recording process. However, the acoustics of various environments are different. With this in mind our coffee-laden engineers developed the unique Para-BASS® system. The “Sweep” control allows you to select a center frequency (the frequency most affected) between 40 and 80hz. The “Gain” control then allows you to boost or cut at the selected frequency.

**Hi- SPL:** A quick way for more bass is to crank the “Gain” control up to 12dB and “Sweep” between 40-80hz while listening to some music. When you get a sudden rise in the bass response, your all set.

**F. Crossover Modules:** Additional crossover modules for the THREE.2 are available from your authorized AudioControl dealer, or you can create custom modules by using the following formula:

$$\frac{7200}{\text{Frequency (Hz)}} = \text{Resistor Value In Kilohms}$$

- Example: For a 2500Hz module -  $7200/2500=2.88\text{Kohms}$

The 24 dB crossover module requires eight resistors of this value.

**Note:** Use 1/4 watt carbon or metal film resistors of a 5% tolerance or better.



## G. Troubleshooting

Problem	Suggestions
No Sound	<ol style="list-style-type: none"><li>1. Is the "Source" button in the wrong position?</li><li>2. Is an Aux in plugged in but not turned on?</li><li>3. Check "Power" and remote turn on for proper voltage. (Is power light on?)</li><li>4. Center the fader control.</li><li>5. Turn up "Input Gain" control.</li><li>6. Check ground connections.</li></ol>
Hiss	<ol style="list-style-type: none"><li>1. Turn down amp gains</li><li>2. Turn down amp gains</li><li>3. Turn down amp gains</li><li>4. Adjust source unit output</li></ol>
Distorting Speakers	<ol style="list-style-type: none"><li>1. Adjust equalization levels</li><li>2. Adjust gain levels</li><li>3. Lower volume level of source unit</li><li>4. Lower sub level</li></ol>
Whine	<ol style="list-style-type: none"><li>1. Confirm that all components are using the same ground point</li><li>2. Change isolation selection of grounding jumpers. See page 7, #15</li></ol>

## If You Like The THREE.2, You'll Love...

The **EQS** Concert Series is our award winning dual band-width, trunk mount equalizer. Thirteen octave and 1/2 octave spaced bands help tame even the most wicked acoustical environment, your car.



**The Epicenter®** Concert Series is our patented (U.S. Patent #4,698,842) bass restoration component, that puts the "woof" back into any woofer. You have to hear it to believe it.

And now a word from the legal department...

## The WARRANTY

People are scared of warranties. Lots of fine print. Months of waiting around. Well, fear no more, this warranty is designed to make you rave about us to your friends. It's a warranty that looks out for you and helps you resist the temptation to have your friend, "...who's good with electronics", try to repair your AudioControl product. So go ahead, read this warranty, then take a few days to enjoy your new THREE.2 before registering on-line and giving us your comments. "Conditional" doesn't mean anything ominous. The Federal Trade Commission tells all manufacturers to use the term to indicate that certain conditions have to be met before they'll honor the warranty. If you meet all of these conditions, we will warranty all materials and workmanship on the THREE.2 for one year from the date you bought it (five years if it is installed by an authorized United States AudioControl dealer) We will fix or replace it, at our option, during that time.

Here are the conditional conditions:

1. You have to go on-line to [audiocontrolregistration.com](http://audiocontrolregistration.com) and fill in the warranty information.
2. You must keep your sales receipt for proof of purchase showing when and from whom the unit was bought. We're not the only ones who require this, so it's a good habit to get into with any major purchase.
3. Your THREE.2 must have originally been purchased from an authorized AudioControl dealer. You do not have to be the original owner, but you do need a copy of the original sales slip.

4. You cannot let anybody who isn't: (A) the AudioControl factory; (B) somebody authorized in writing by AudioControl to service your THREE.2. If anyone other than (A) or (B) messes with your THREE.2, that voids your warranty.

5. The warranty is also void if the serial number is altered or removed, or if the THREE.2 has been used improperly. Now that sounds like a big loophole, but here is all we mean by it.

Unwarranted abuse is: (A) physical damage (don't use the THREE.2 for a car jack); (B) improper connections (120 volts into the power jack can fry the poor thing); (C) sadistic things.

This is the best mobile product we know how to build, but if you mount it to the front bumper of your car, something will go wrong.

6. If an authorized United States AudioControl dealer installs the THREE.2, the warranty is five years.

Assuming you conform to 1 through 6, and it really isn't all that hard to do, we get the option of fixing your old unit or replacing it with a new one.

### Legalese Section

This is the only warranty given by AudioControl. This warranty gives you specific legal rights that vary from state to state. Promises of how well your THREE.2 will perform are not implied by this warranty. Other than what we have covered in this warranty, we have no obligation, express or implied. Also, we will not be obligated for direct or indirect consequential damage to your system caused by hooking up the AudioControl THREE.2. Failure to send in a properly completed warranty card negates any service claims.

## THREE.2 SPECIFICATIONS

All specifications are measured at 14.4 VDC (standard automotive voltage). As technology advances, AudioControl reserves the right to continuously change our specifications, like our weather.

Maximum input/output level.....	9.5Vrms/13V peak
Frequency response.....	20Hz-20kHz;+/-1dB
Total harmonic distortion.....	0.01%
Signal to Noise ratio.....	-110dB
Input Impedance.....	20K ohms
Output Impedance.....	150 ohms
Input gain.....	0-20dB
Equalization Cut/Boost.....	+/-12dB
Crossover slope.....	24dB/octave Linkwitz Riley
Factory crossover setting.....	90Hz
Power supply.....	High headroom PWM switching
Power draw.....	250mA
Recommended fuse rating.....	1 Amp
Illumination Color.....	Blue or Red (LED back lighting)
Size.....	1"H x 6.75"W x 5"D
Weight.....	2 lbs
Country of origin.....	U.S.A

AudioControl, Making Good Sound Better, Performance Match, The Epicenter, EQS, EQL, EQX, THREE.2, and Para-BASS are all trademarks of Electronic Engineering and Manufacturing, Inc. This literature was conceived, designed, and written on a bleak, windy, and dreary rain-drenched day at our home in the Pacific Northwest Rainforest. The coffee was hot. No interns were present.



# **AudioControl**®

*Making Good Sound Better*®

22410 70th Avenue West  
Mountlake Terrace, WA 98043 USA  
425-775-8461 • Fax 425-778-3166  
[www.audiocontrol.com](http://www.audiocontrol.com)

© 2010, AudioControl, a division of Electronic Engineering and Manufacturing, Inc. All rights reserved

P/N 913-105-0